

2- Drawer Nightstand



For Residential Use Only

Time to get started

Set up a clean and soft workplace to avoid damage during assembly. You can use the box and internal protections as a cover. It also helps to double-check if you have got all the pieces and parts before diving into the assembly.

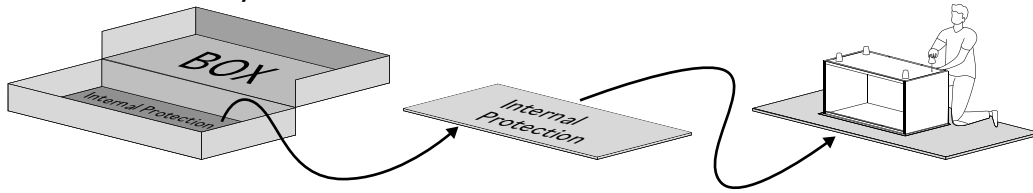

**Estimated time
for assembly**

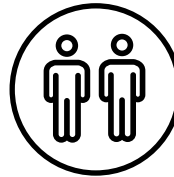

2 People Build

People recommended

for assembly

Make it a team effort!
Grab a friend for quicker,
easier assembly.

Tools Needed

Grab a Phillips head screwdriver and a hammer to conquer this assembly. We will also need a hammer to help.

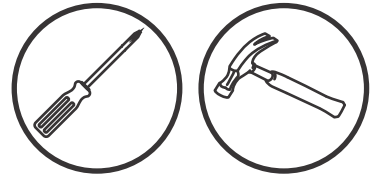

Use power tools with caution

This furniture is made of Solid Wood and Composite Wood, soft materials. If you choose to use power tools, set it to the slower setting. Be careful! Power tools can cause cracking or damage to the furniture, they can also damage the hardware if misused.

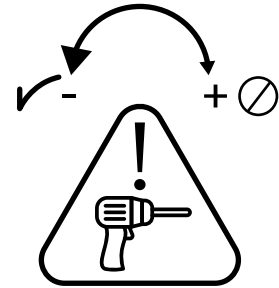





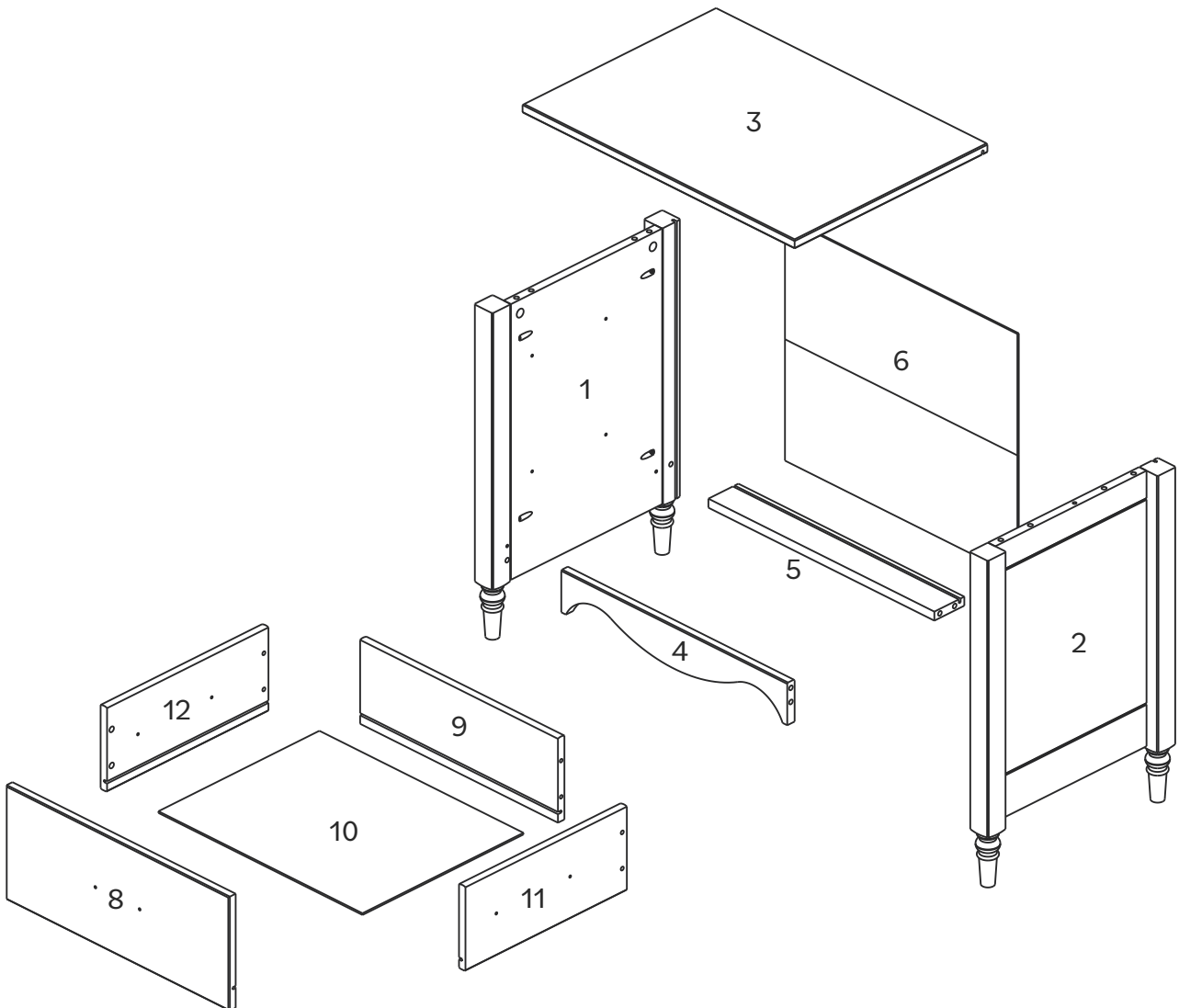







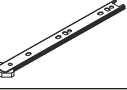

Parts List

Part Number	Description	Quantity
1	Left Panel	1
2	Right Panel	1
3	Top Panel	1
4	Front Rail	1
5	Back Rail	1
6	Back Panel	1
8	Drawer Front	2
9	Drawer Back	2
10	Drawer Bottom	2
11	Right Drawer Side	2
12	Left Drawer Side	2



Hardware List

Part	Size	Name	Quantity
A		Dovetail	4
B		Dovetail Lock	8
C		Plastic Screw	8
D	 6x12mm	Screw	8
E	 6x14mm	Screw	8
F1	 250mm	Outer Slider	4
F2	 250mm	Inner Slider	4
G		Handle	2
H	 M4x19mm	Screw	4
I	 8x30mm	Wooden dowel	8
J	 6x31mm	Cam bolt	8
K	 15x11mm	Cam Lock	8
L		Wedge	10
M	 3,5X14mm	Screw	10

*The hardware quantities listed above are required for proper assembly.
Extra hardware pieces may be included.*

Introducing The Easy Assembly Drawer System

Say Goodbye to Assembly Hassle!

We understand that assembling drawers can be the most time-consuming and tedious part of putting together your new furniture. That's why we've developed the Easy Assembly Drawer System - to make the process easy!

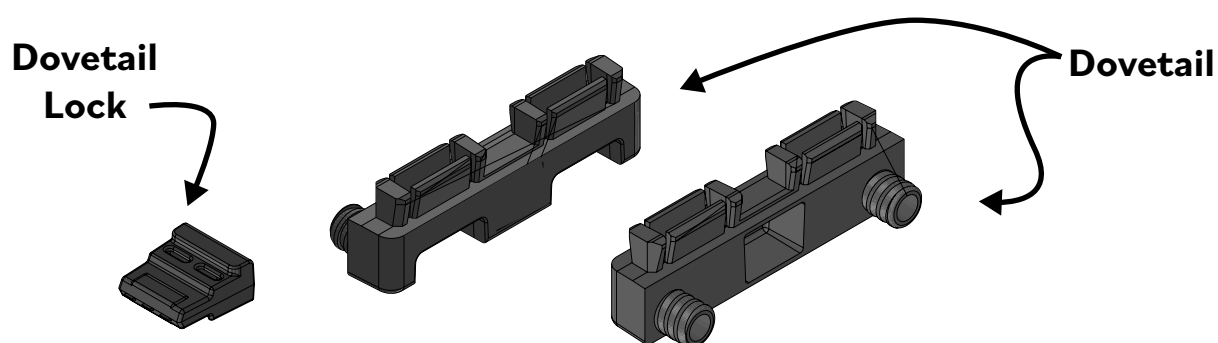

Why You'll Love Our Easy Assembly Drawer System:

Quick & Easy: Our new drawer hardware significantly reduces your assembly time. Get it done in no time!

Minimal Effort Required: Designed to be super simple, you'll need little to no tools to get the job done.

Built to Last: Strong and sturdy, our system ensures that your drawers stay solid and reliable.

Let's set the stage to assembly:

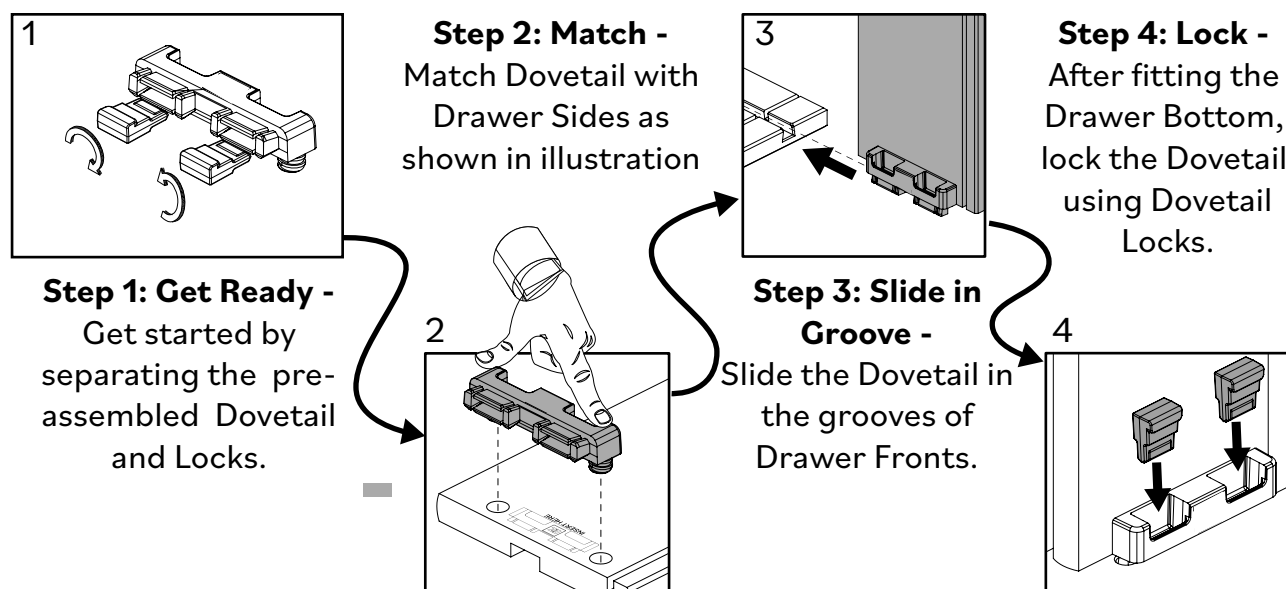

Attention: In the next steps there are more details to help you assemble.

Step 1

Prepare the Dovetails (A) by removing the Dovetail Locks (B) from the Dovetails (A).

1st

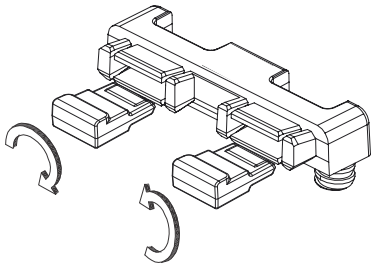

2nd

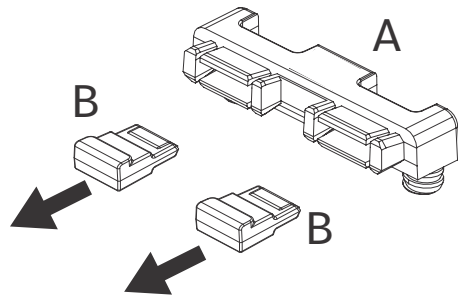

Step 2

Snap the Dovetails (A) into place on Right Drawer Sides (11) and Left Drawer Sides (12). Press the Dovetails until they are completely attached. Use a hammer if necessary.

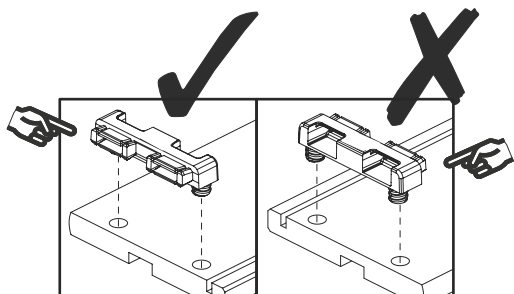

Press the piece until it is completely attached

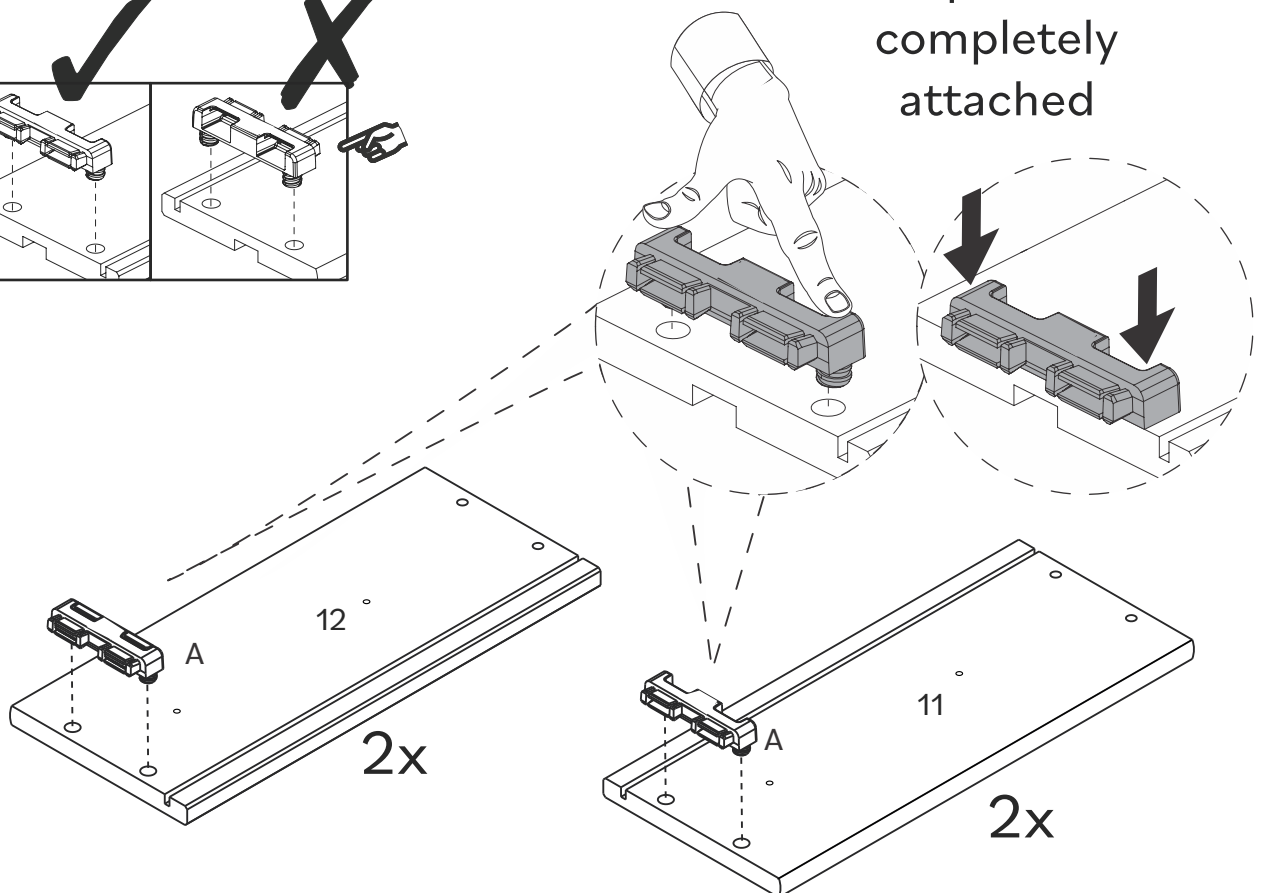

Step 3

Slide the Dovetail (A) on the Right Drawer Panel (11) and Left Drawer Panel (12) into the grooves on the Drawer Front (8).

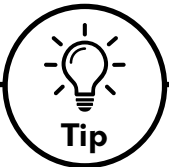
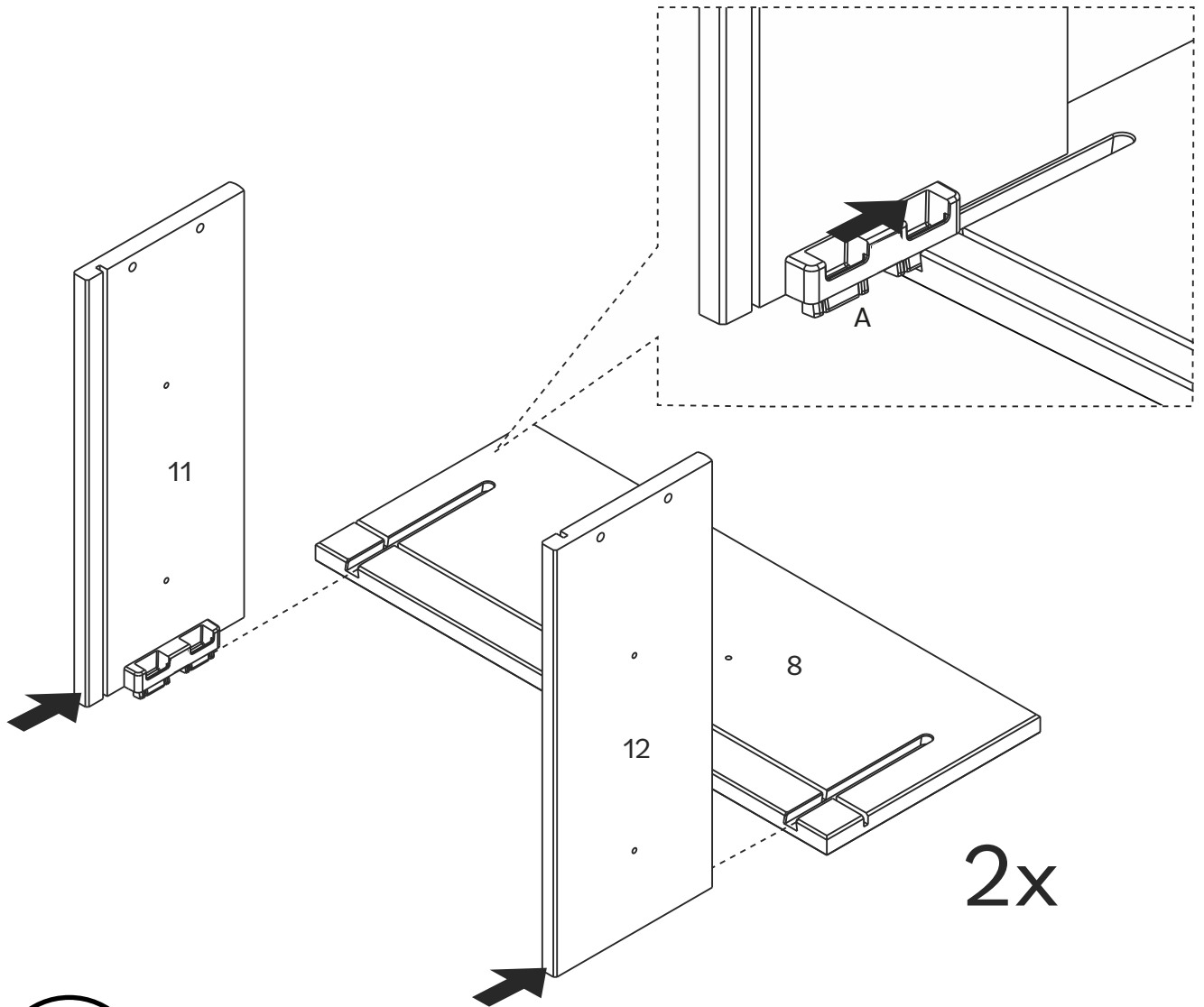

To keep your product looking its best and scratch-free, try assembling it on a soft surface like carpet or a blanket. This helps prevent any accidental scratches and keeps your furniture in top shape!

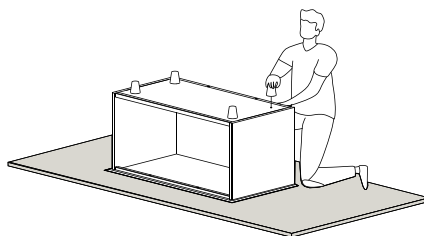

Step 4



Slide Drawer Bottom (10) between the grooves on Right Drawer Side (11) and Left Drawer Side (12) fitting in Drawer Front (8).

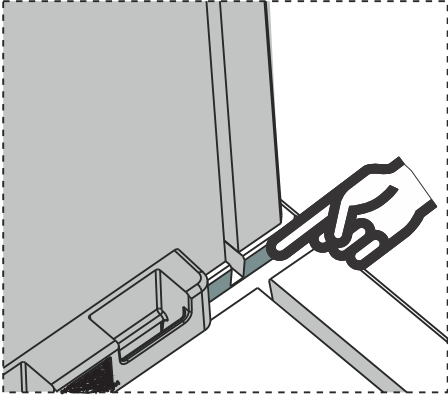

Align the grooves on the Drawer Sides and Drawer Front to receive the Drawer Bottom

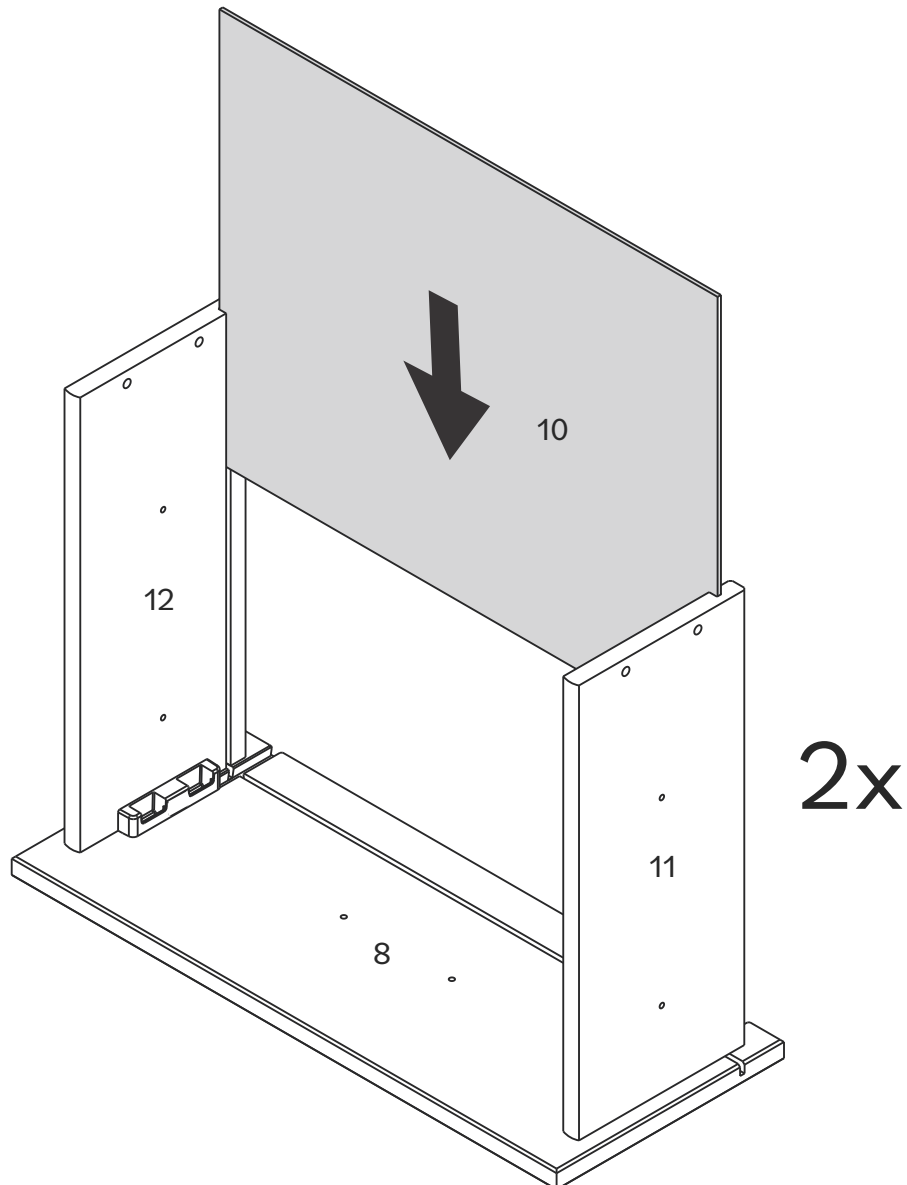

Step 5



To secure the Drawer sides, insert the Dovetail Locks (B) into the Dovetails (A). Use a hammer if necessary.

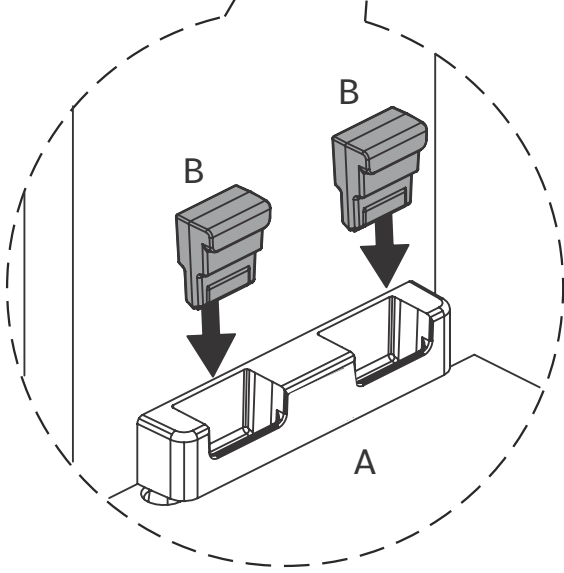
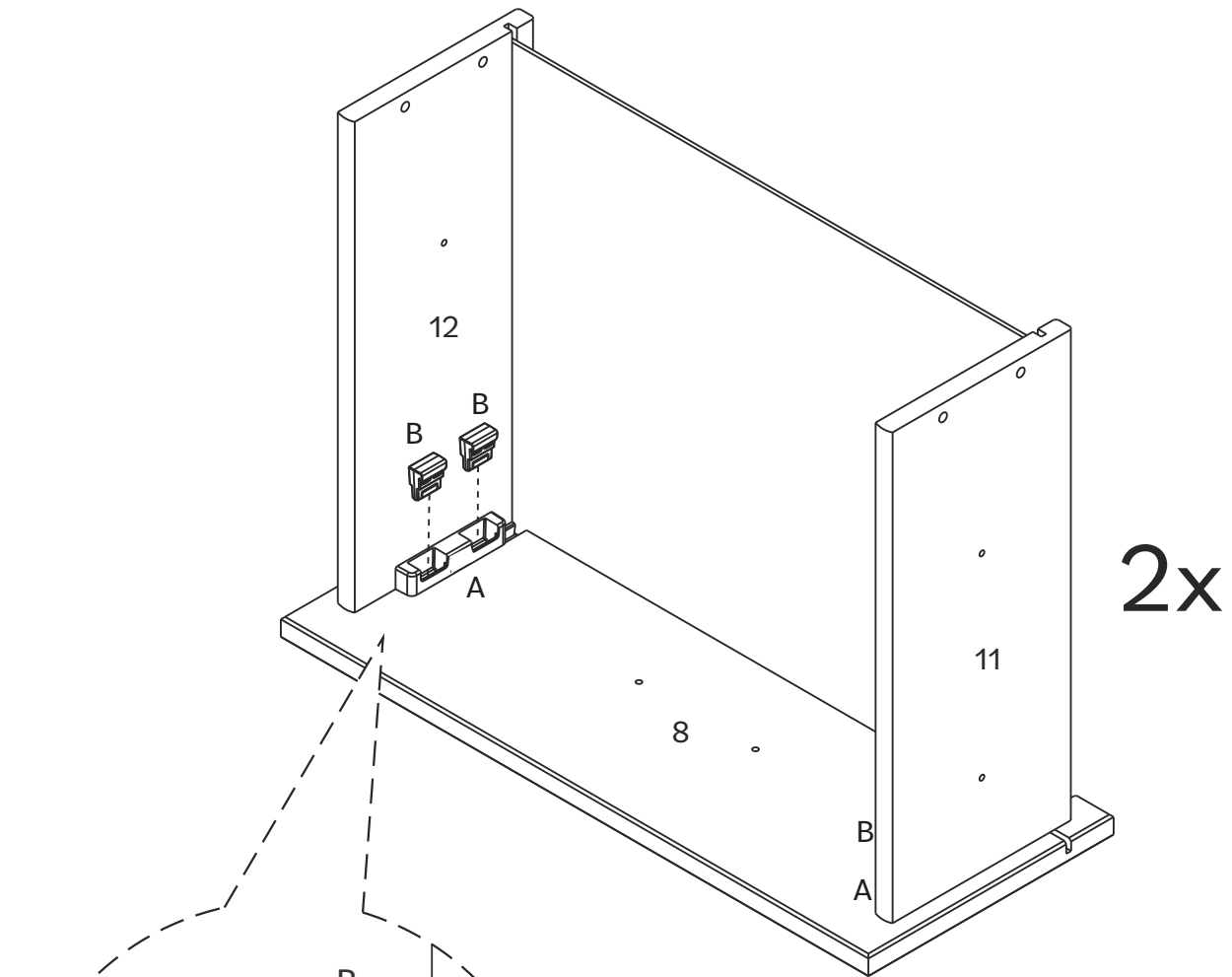

Once this step is completed, your product should look like this:

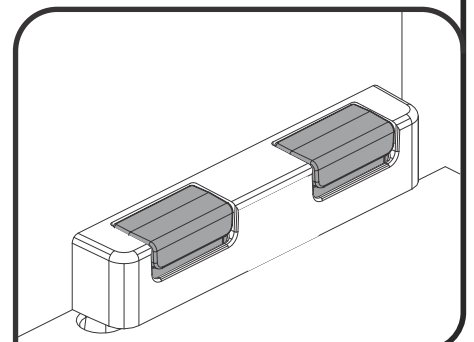

Step 6



Fit Drawer Bottom (10) to Drawer Back (9) and secure using Plastic Screw (C), you can insert it with your hands or using a hammer.

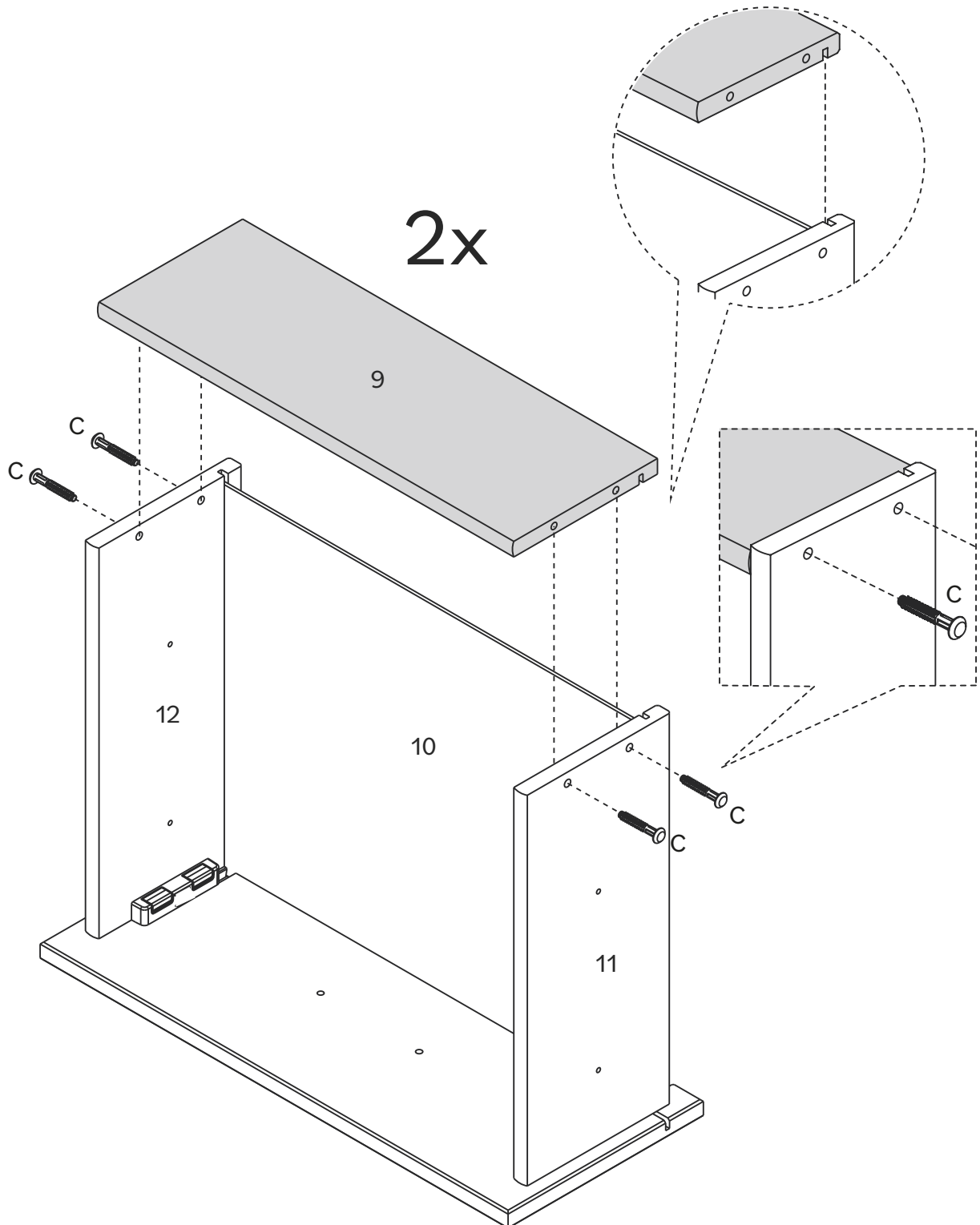

Step 7



Attach Inner Sliders (F2) to Right Drawer Sides (11) and Left Drawer Sides (12) using Screw (D) and a Phillips screwdriver.

Separate parts F1 and F2 by pressing the lock.

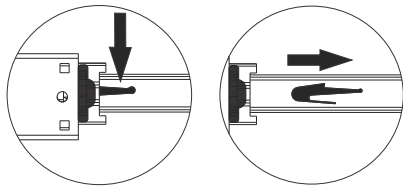
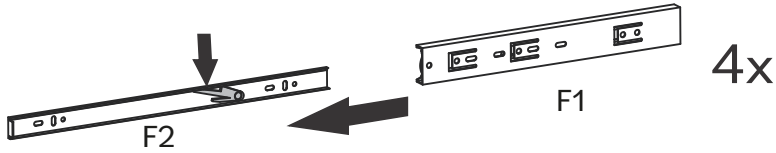

2x

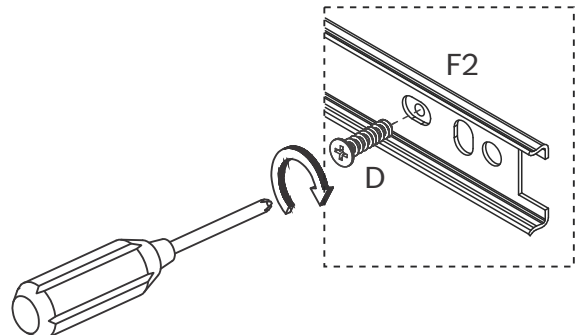
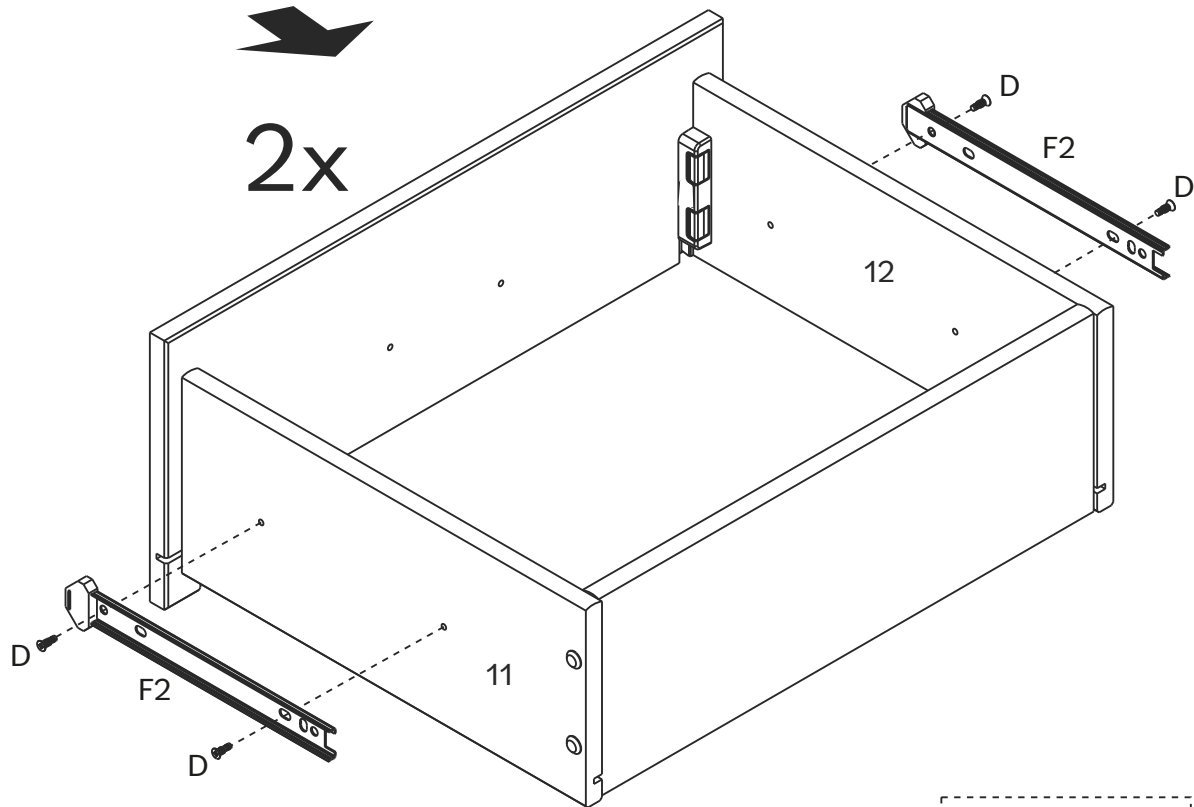

Step 8



Use Screws (H) and a Phillips screwdriver to secure Handles (G) to Drawer Fronts (8).

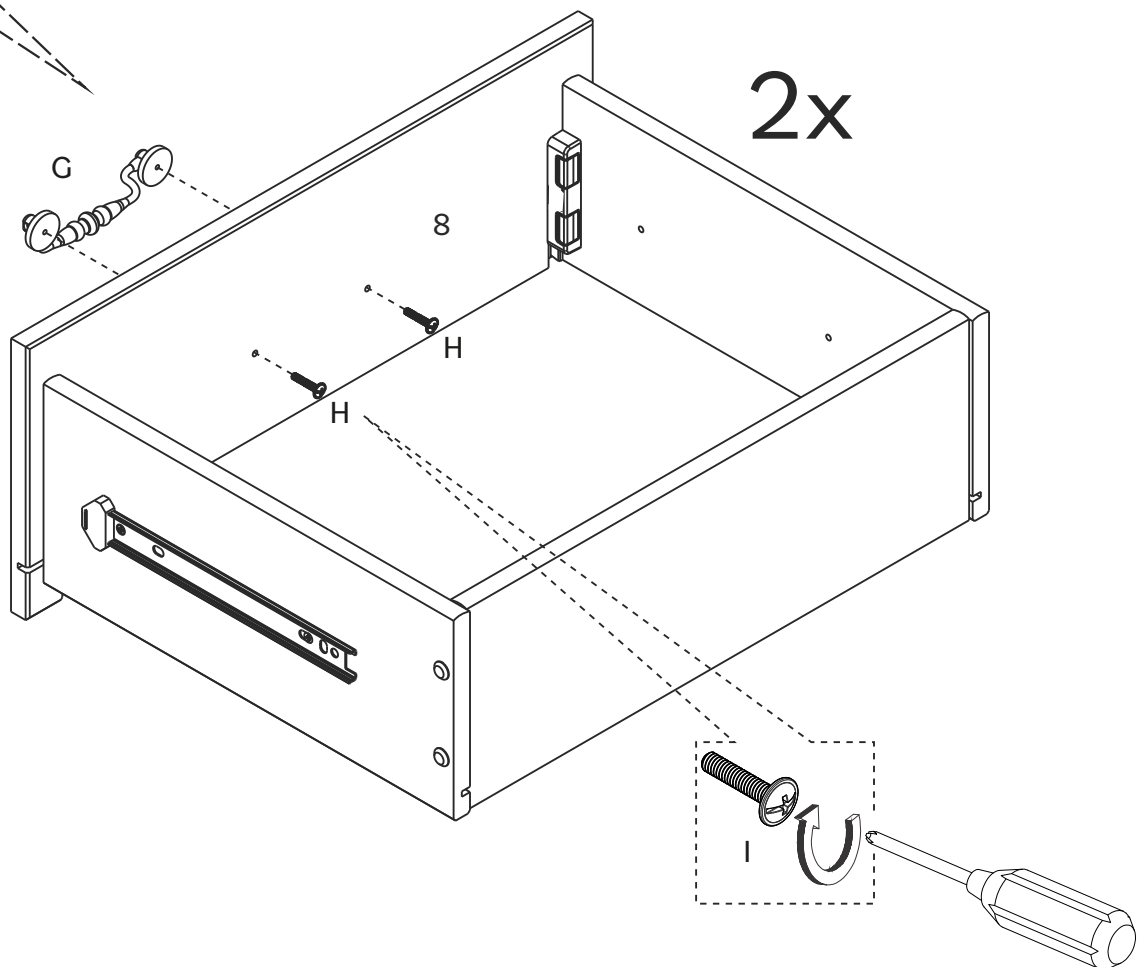
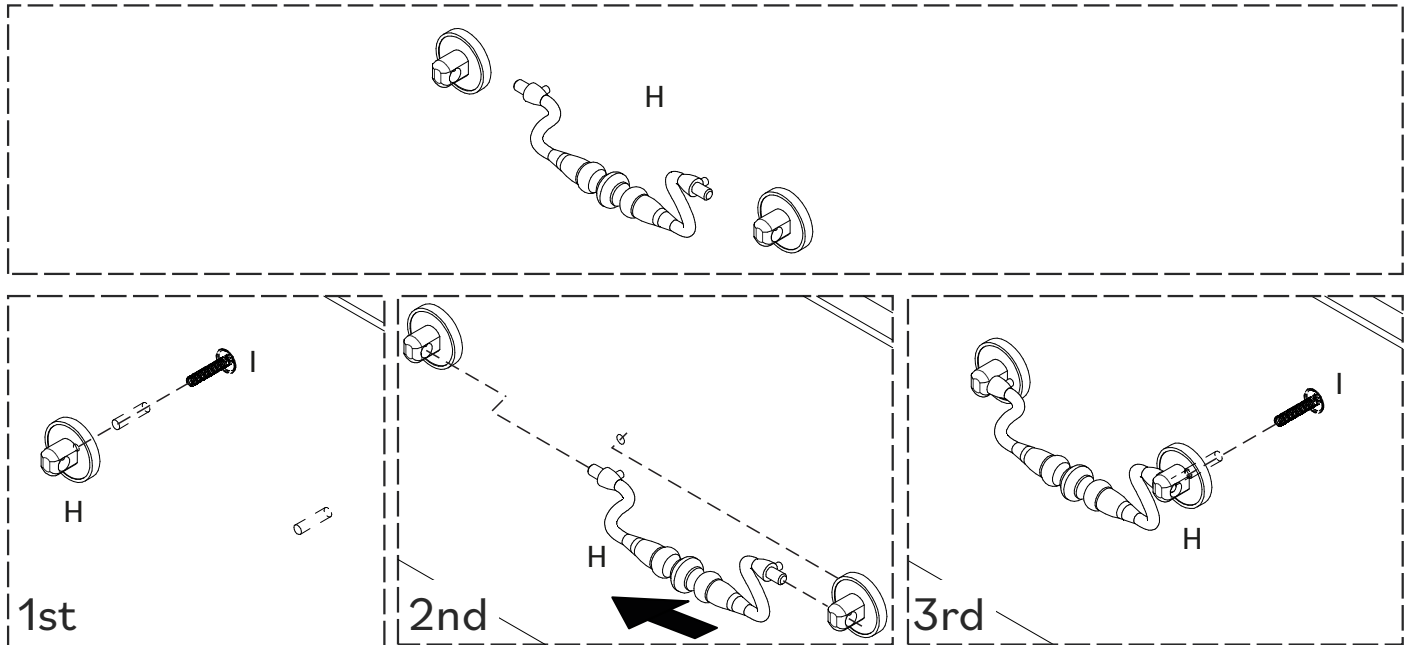

Step 9

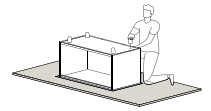

Insert Wooden Dowels (I) into Left Panel (1), Right Panel (2), Front Rail (4) and Back Rail (5).

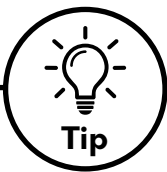
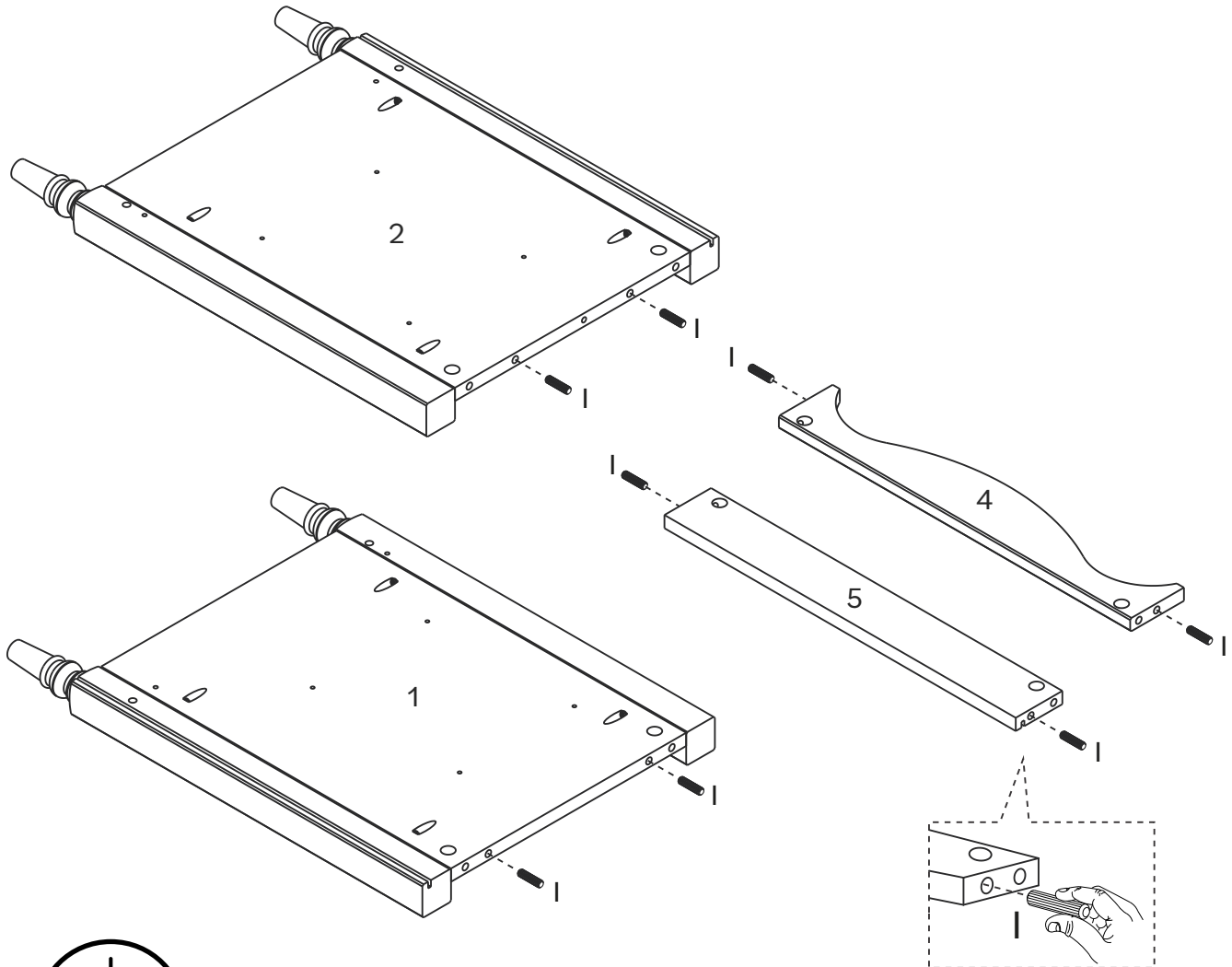

Tip

Wood Dowels

Dowels are essential in furniture assembly to create strong, precise connections. They ensure structural integrity, prevent shifting, and simplify alignment, resulting in sturdier, longer-lasting furniture.

Follow these steps:

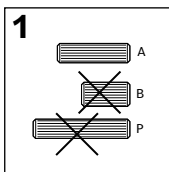

1: Select the appropriate size dowel according with step.

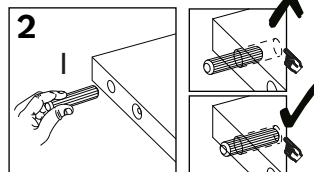

2: Insert into drilled hole and press firmly to ensure placement is set.

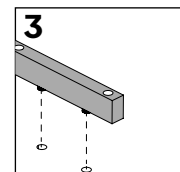

3: Align the dowel with corresponding piece and press together until secure.

Step 10

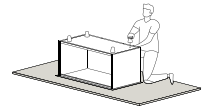

Attach Cam Bolts (J) to Left Panel (1), Right Panel (2) and Top Panel (3).

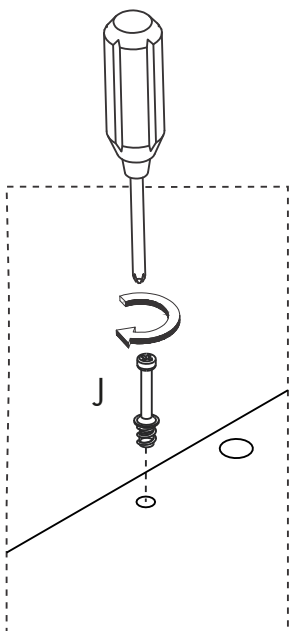
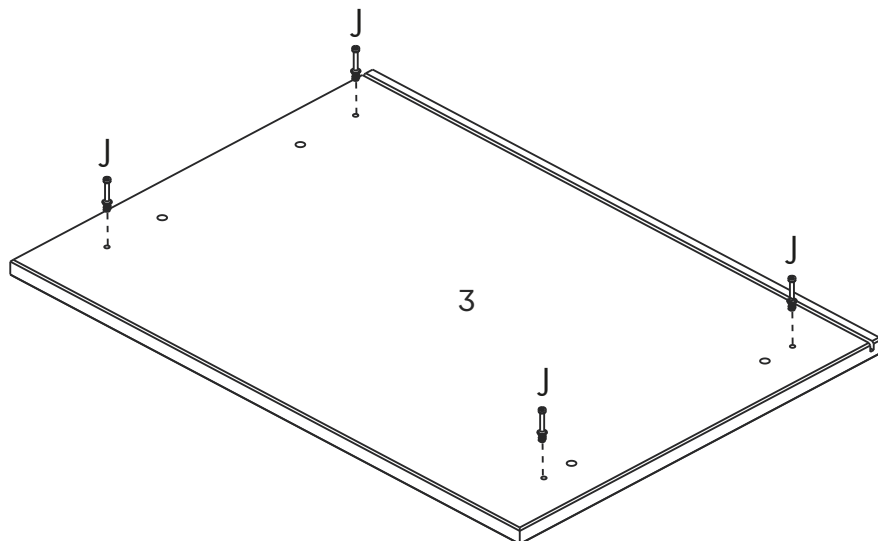
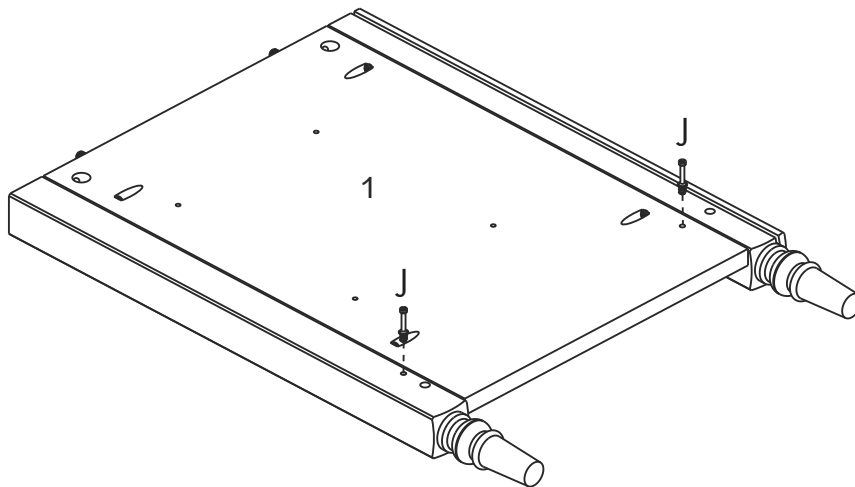
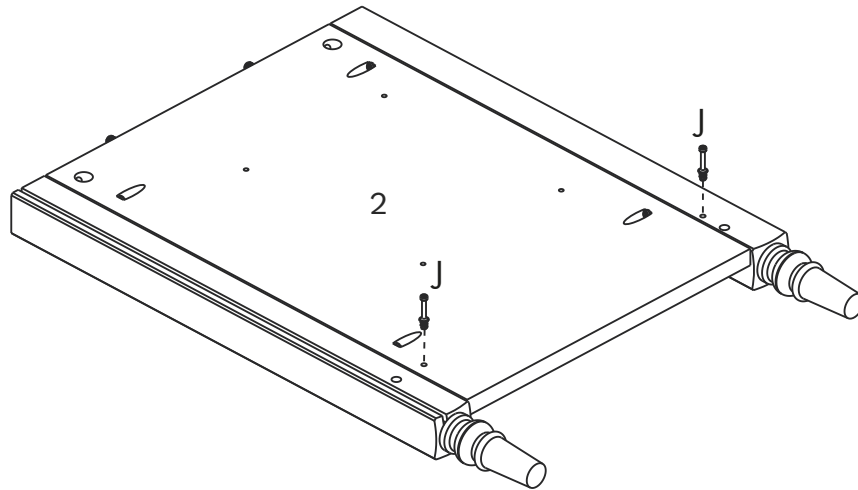

Step 11

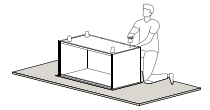

Secure Outer Slider (F1) to Left Panel (1) and Right Panel(2) using Screw (E) and a Phillips screwdriver.

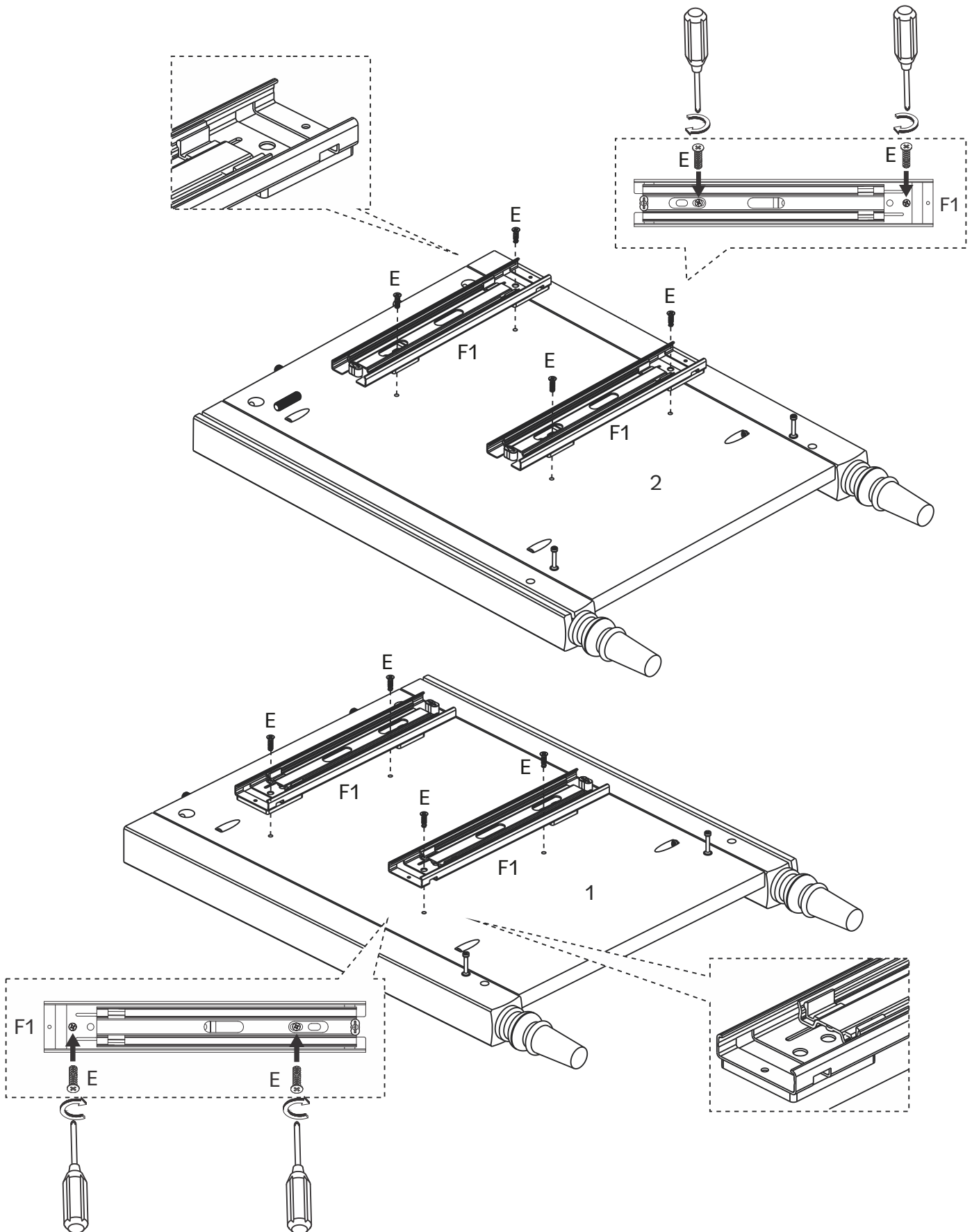

Step 12



Attach Front Rail (4) and Back Rail (5) to Left Panel (1) using Cam Lock (K) and a Phillips screwdriver.

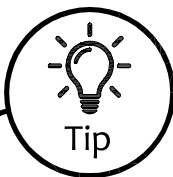
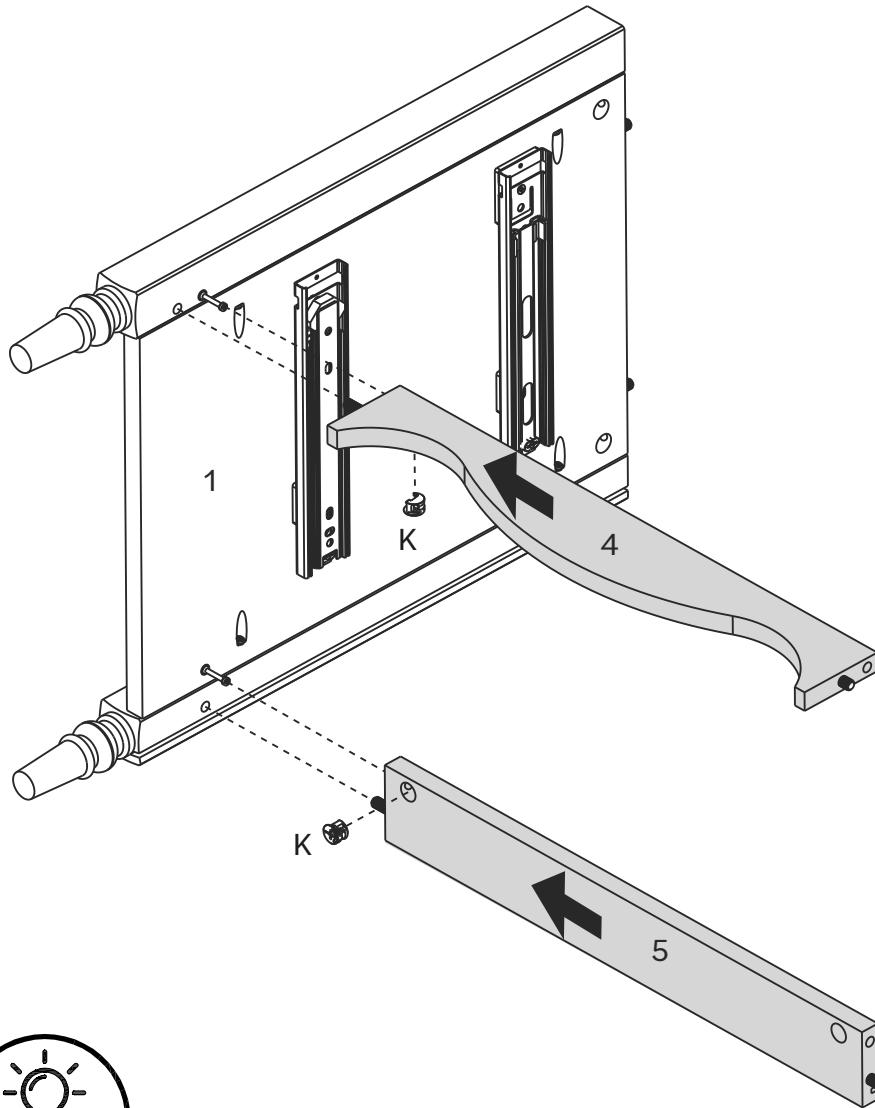

Tip

Cam Locks

Cam Locks help to securely join two pieces together. Follow these easy steps.

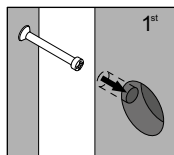

1: Insert Cam Bolt into bolt holes on the flat side. Don't over tighten!

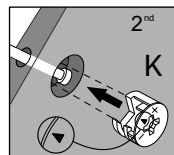

2: Assemble both parts together. The cam bolts goes in the drilled holes that have a circular hole on the side, you should be able to see the cam bolt through it. After fitting parts together insert the cam lock on the side holes.

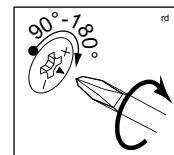

3: On the back of the Cam Lock will be a "C" shape. Insert the Cam Lock so the opening of the "C" fits over the Cam Bolt. Tighten with the screwdriver.

Step 13



Join Right Panel (2) to Front Rail (4) and Back Rail (5) using Cam Lock (K) and a Phillips screwdriver.

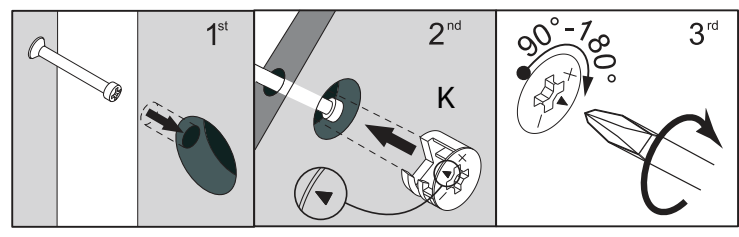
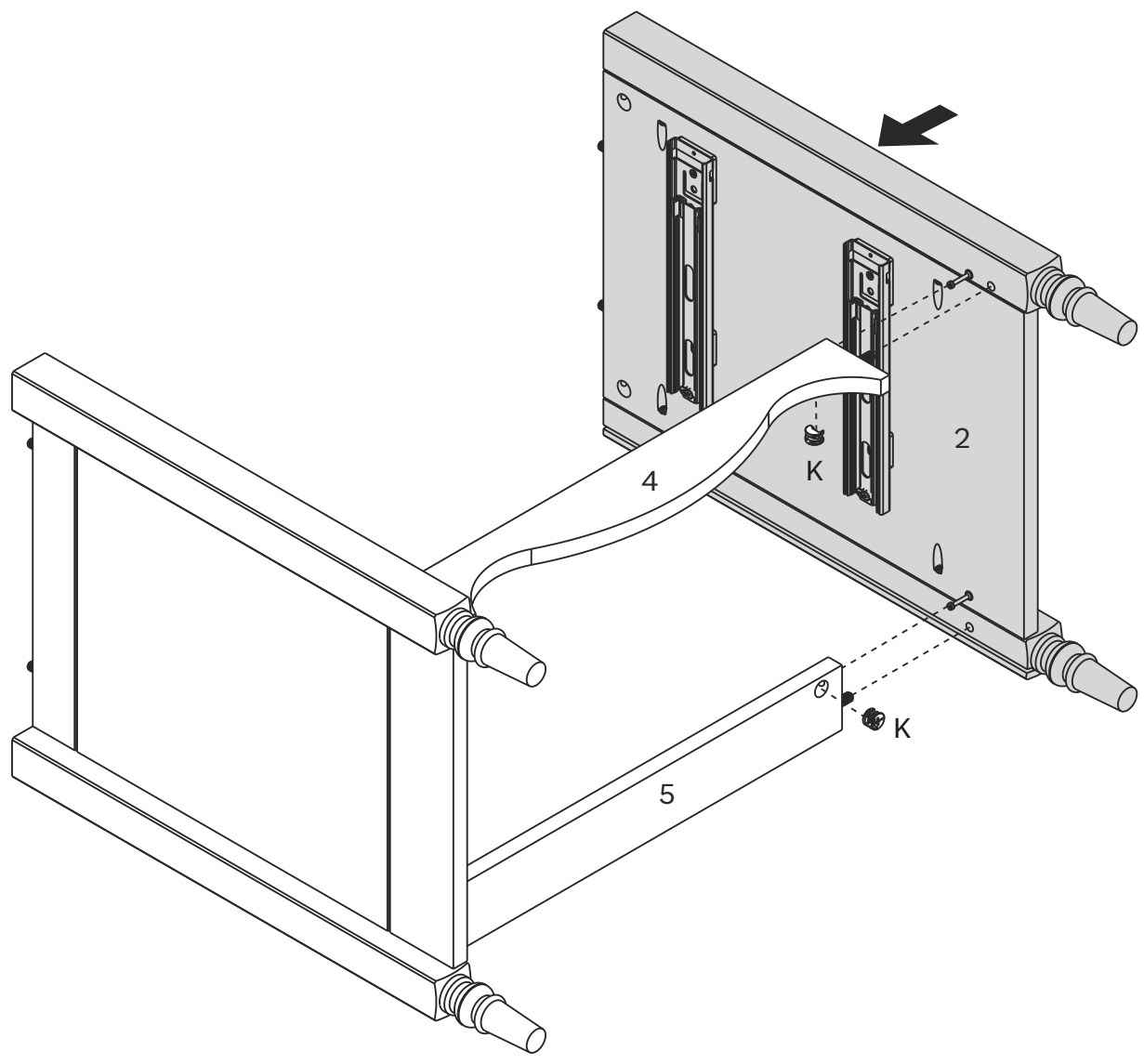

Step 14

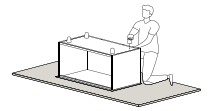

Slide Back Panel (6) on the grooves on Left Panel (1) and Right Panel (2), fitting in Back Rail (5).

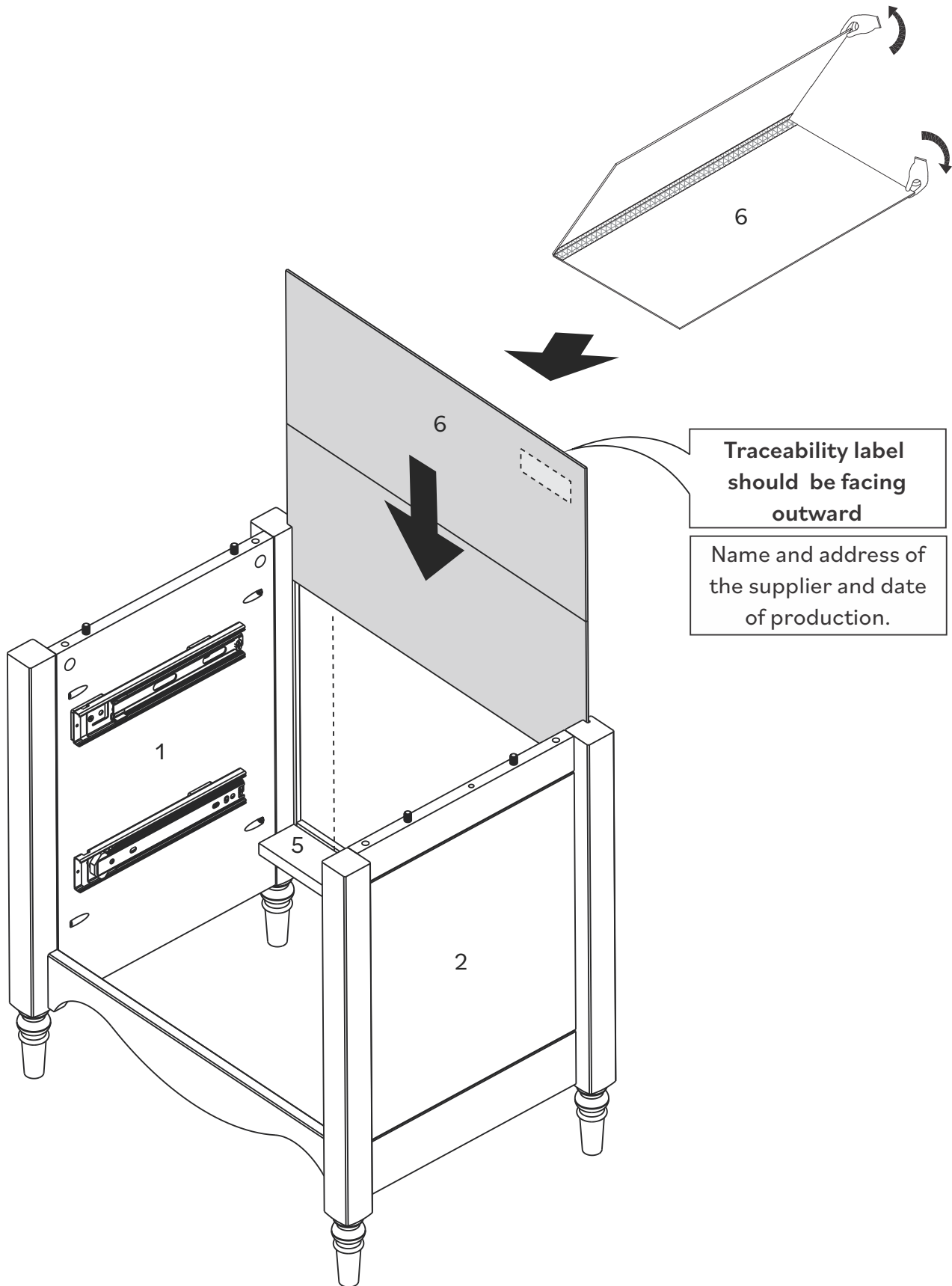

Traceability label
should be facing
outward

Name and address of
the supplier and date
of production.

Step 15



Secure Top Panel (3) to Left Panel (1) and Right Panel (2) using Cam Locks (K) and a Phillips screwdriver.

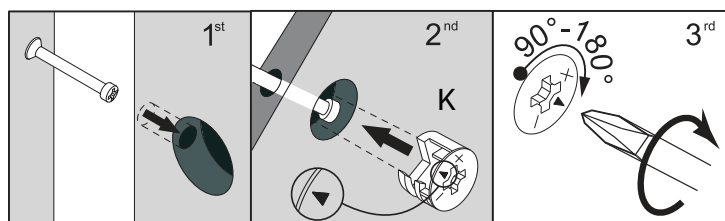
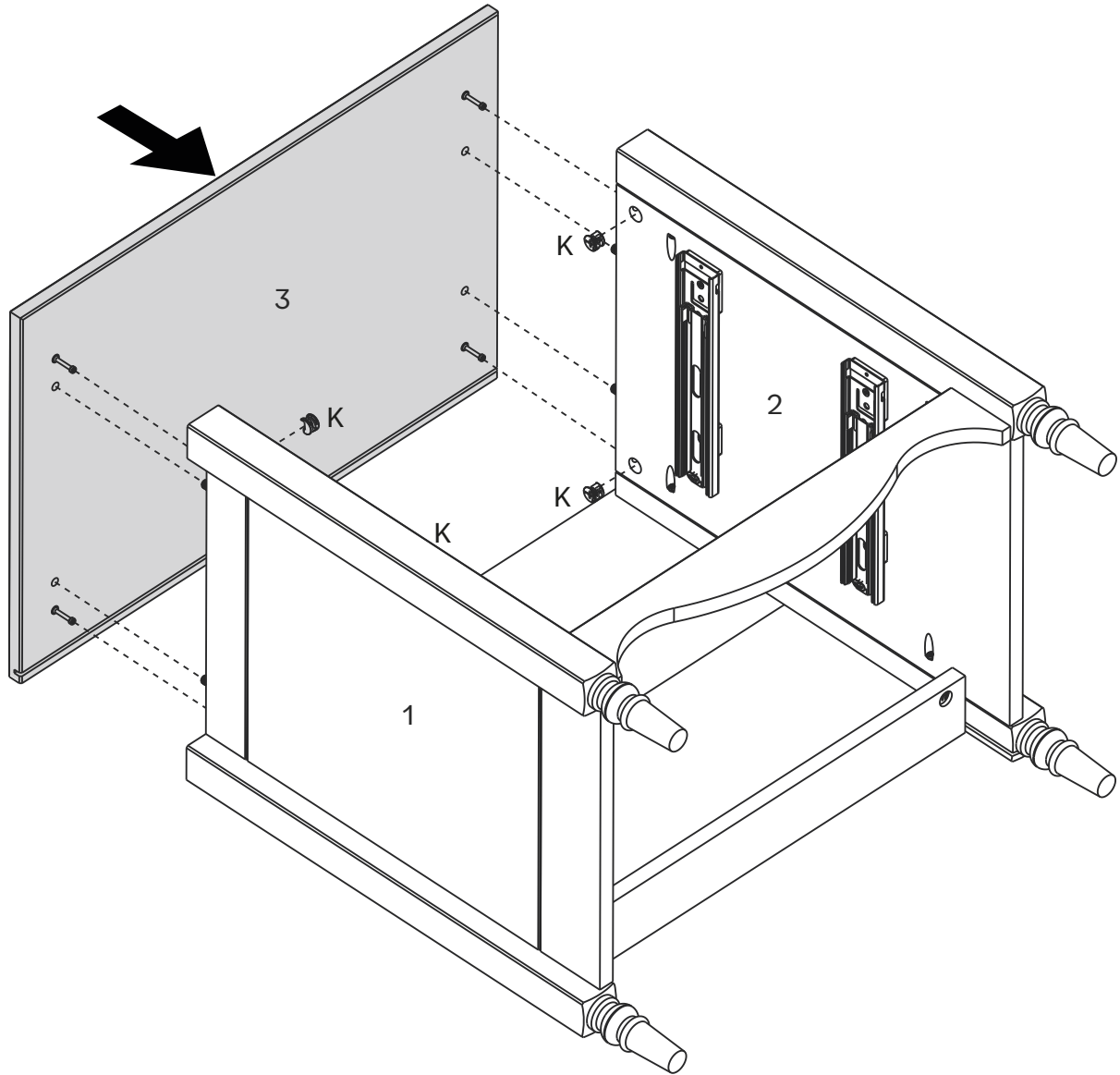

Step 16

Secure Back Panel (6) fitting Wedge (L) and screw (M) between the panel and the grooves. Use and a Phillips screwdriver.

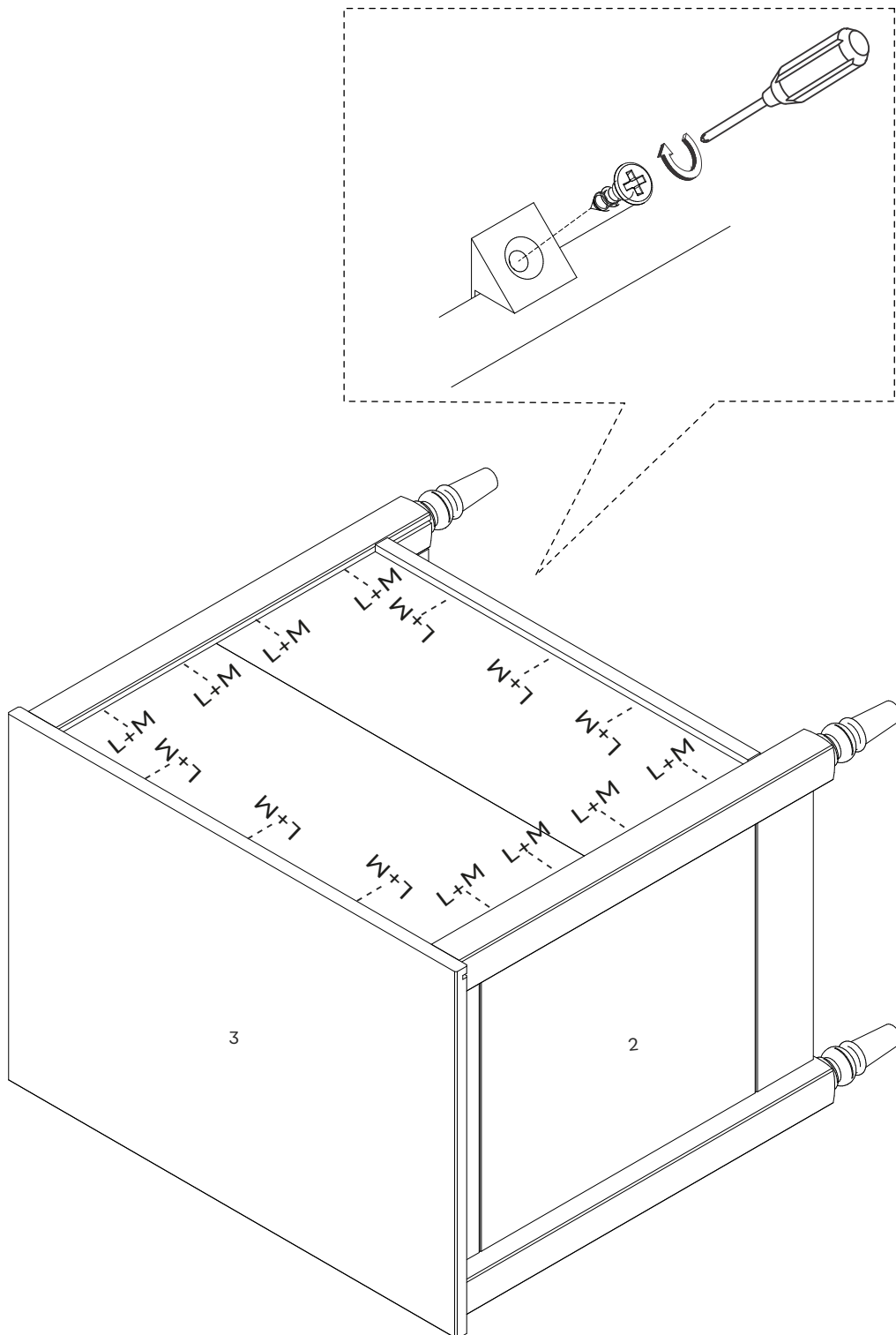

Step 17

Place the Drawers one at a time using the slider, pay attention to position them correctly aligning Outer and Inner Slider.

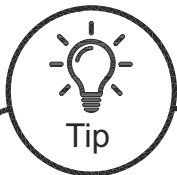
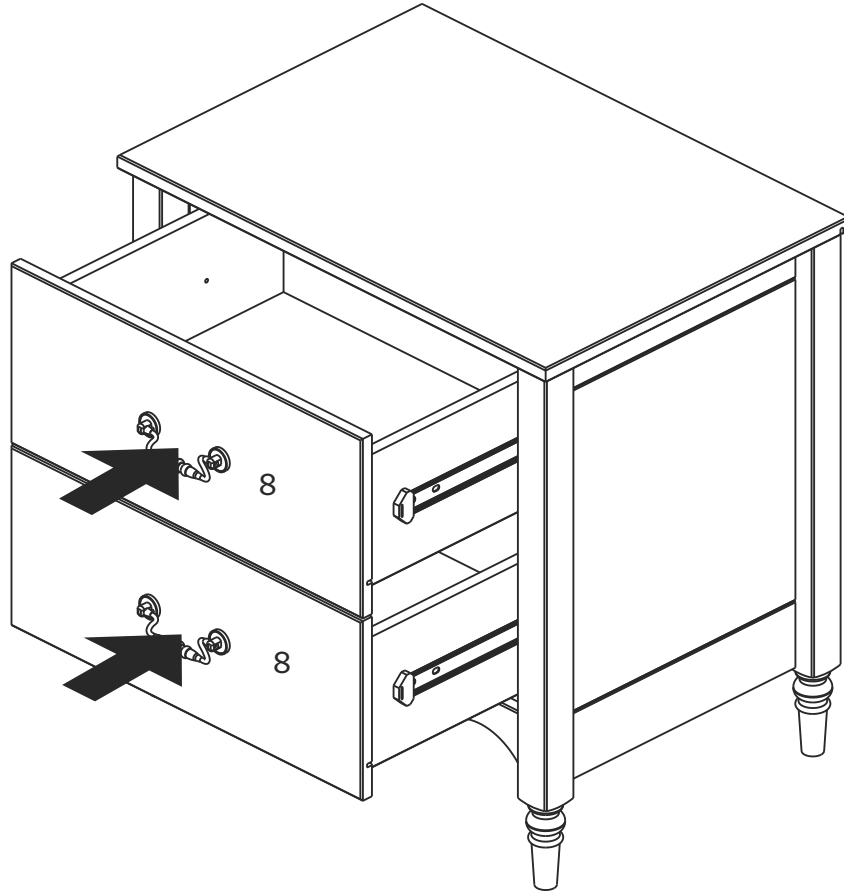

Tip

Insert your Cabinet Drawer Correctly

Line up Outer and Inner Slider and push the drawer slightly inside the unit, once you feel the connection push the drawer entirely into place. It may not be a smooth gliding at first, but it improves once fully connected.

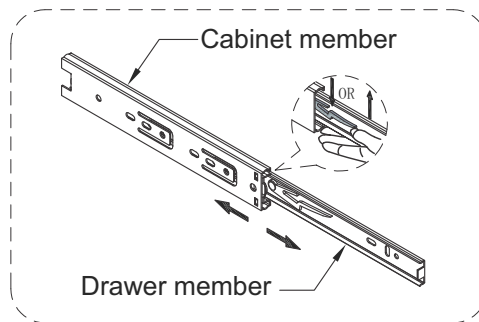

Removing the Drawer

There is a white lever in each slider, to remove the drawers pull the drawer out until you see the lever. Push one lever up and the other down, while pushing, bring the drawer out

To Disassemble



If it is necessary to disassemble, remove the Dovetail locker (B) with a Slotted head screwdriver.

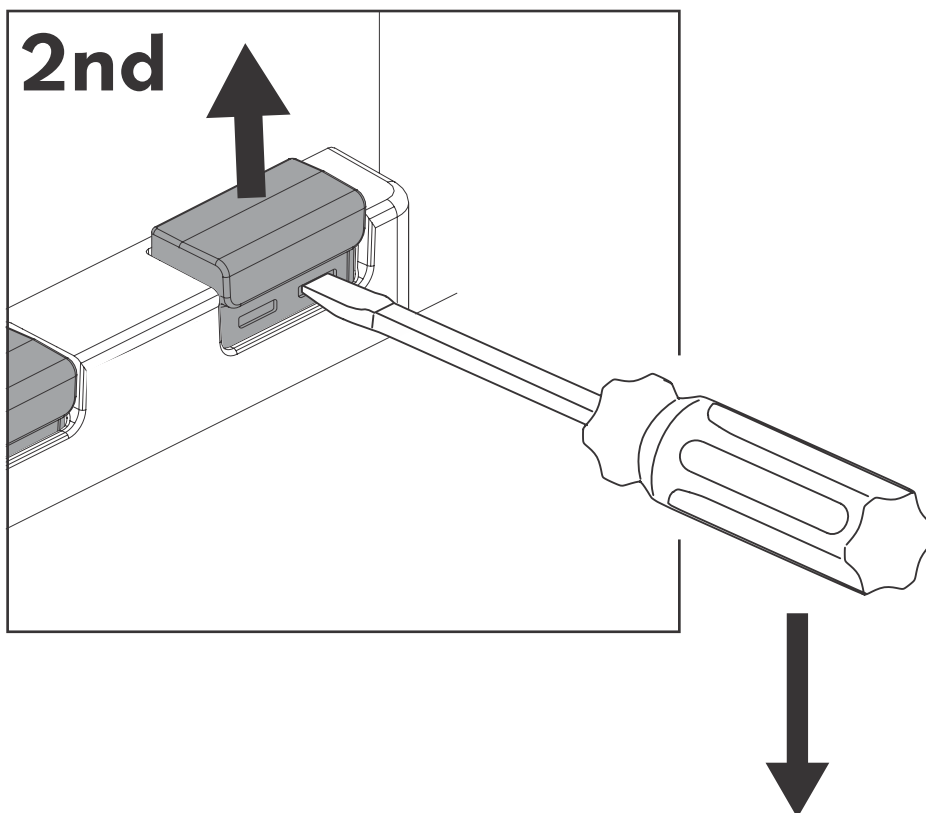
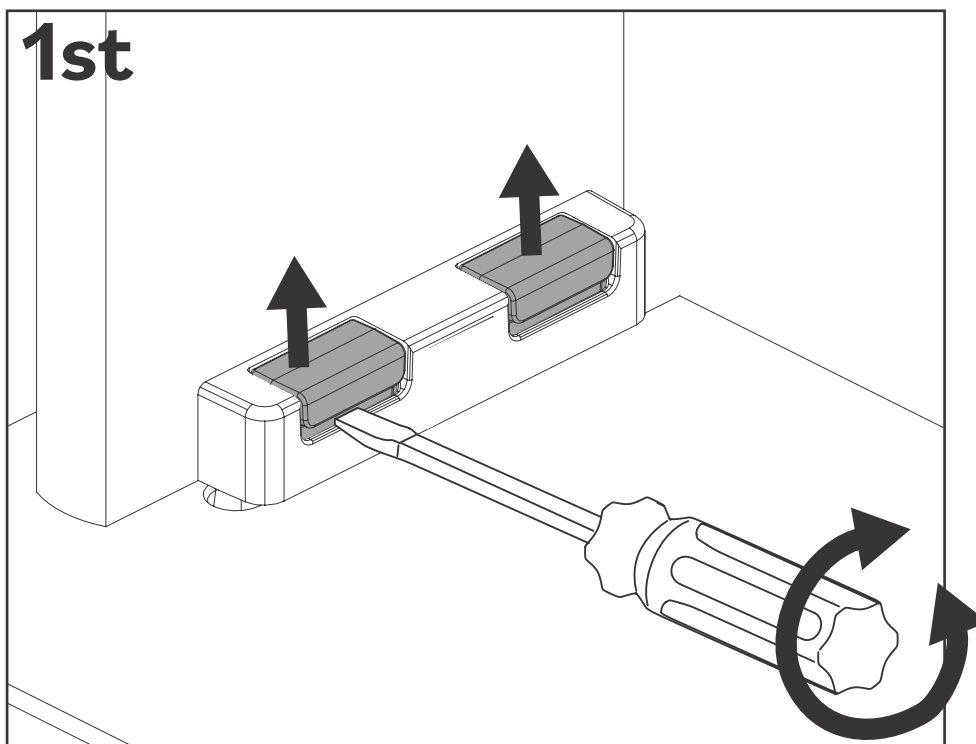

You did it! Enjoy your new Nightstand!

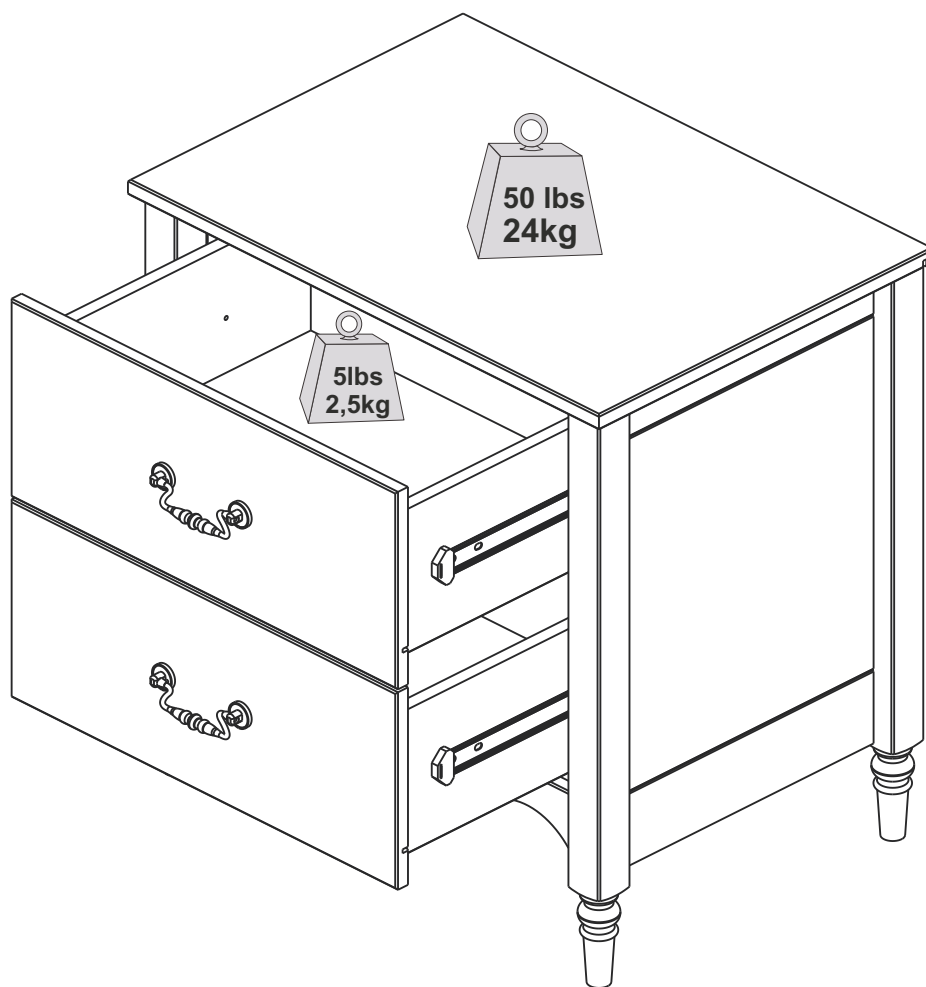

Congratulations on your new piece of furniture!

Table de Chevet à 2 Tiroir
Mesita de Noche de 2 Cajone



Pour usage résidentiel seulement

Sólo para uso residencial

Il est temps de commencer / Hora de empezar

Prépare un lieu de travail propre et souple pour éviter tout dommage lors de l'assemblage. Tu peux utiliser la boîte et les protections internes comme base. Vérifie également que tu disposes de toutes les pièces et parties avant de te lancer dans l'assemblage.

Prepare un lugar de trabajo limpio y blando para evitar daños durante el montaje. Puede utilizar la caja y las protecciones internas como base. Comprueba también que tiene todas las piezas y partes antes de sumergirse en el montaje.

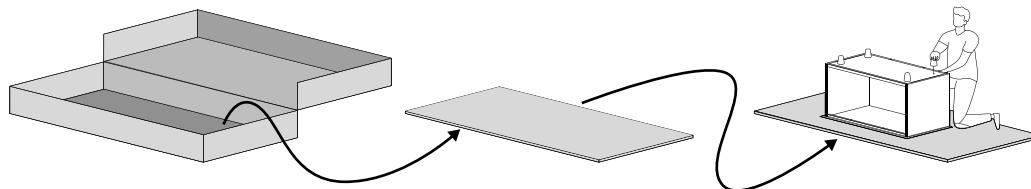

**Temps de montage
estimé**

**Tiempo estimado de
montaje**

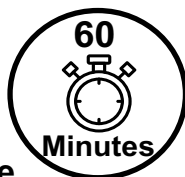

2 Personnes
2 Personas

Personnes recommandées pour le montage

Fais-en un effort d'équipe !
Appelle un ami pour un assemblage
plus rapide et plus facile.

Personas recomendadas para el montaje

¡Hágalo en equipo!
Llame a un amigo para que el
montaje sea más rápido y sencillo.

Outils nécessaires

Munis-toi d'un tournevis, tournevis cruciforme et marteau pour réaliser cet assemblage.

Herramientas requeridas

Tome un destornillador, destornillador Phillips y martillo para conquistar este montaje.

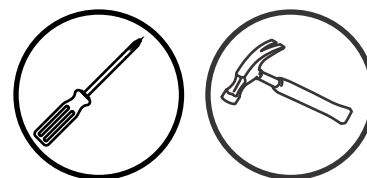

Utilise les outils électriques avec précaution

Ce meuble est réalisé en Bois Massif et Bois Composite, des matériaux souples. Si tu choisis d'utiliser des outils électriques, règle-les sur le mode le plus lent. Fais attention à toi ! Les outils électriques peuvent provoquer des fissures ou endommager les meubles, mais aussi les autres composants s'ils sont mal utilisés.

Utilice las herramientas eléctricas con cuidado.

Este mueble está fabricado con madera maciza y madera compuesta, materiales blandos. Si decide utilizar herramientas eléctricas, ajústelas al ajuste más lento. Tenga cuidado. Las herramientas eléctricas pueden causar grietas o daños en el mueble, pero también en los herrajes si se utilizan mal.

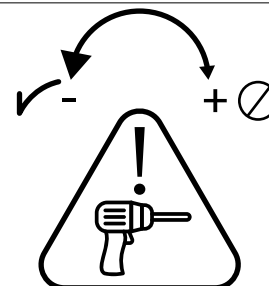





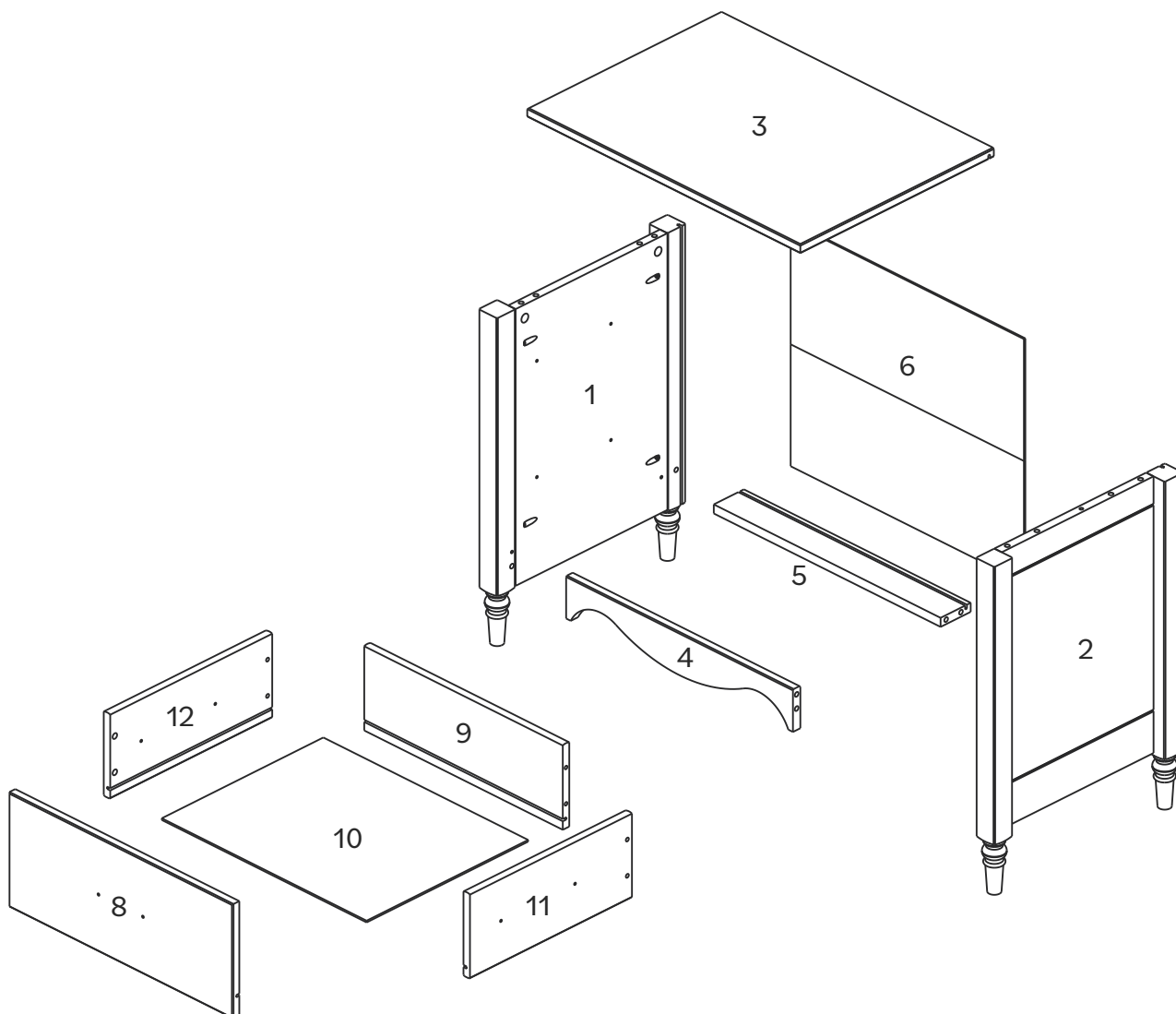





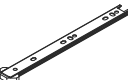
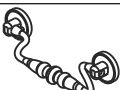

Liste de pièces / Lista de piezas

Nombre de pièces Número de pieza	Description Descripción	Quantité Cantidad
1	Left Panel Left Panel	1
2	Right Panel Right Panel	1
3	Top Panel Top Panel	1
4	Front Rail Front Rail	1
5	Back Rail Back Rail	1
6	Back Panel Back Panel	1
8	Drawer Front Drawer Front	2
9	Drawer Back Drawer Back	2
10	Drawer Bottom Drawer Bottom	2
11	Right Drawer Side Right Drawer Side	2
12	Left Drawer Side Left Drawer Side	2

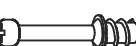

Liste de composants / Lista de hardware

Partie Parte	Taille Tamaño	Nom Nombre	Quantité Cantidad
A 		Dovetail Dovetail	4
B 		Dovetail Lock Dovetail Lock	8
C 		Plastic Screw Plastic Screw	8
D 	6x12mm	Screw Screw	8
E 	6x14mm	Screw Screw	8
F1 	250mm	Outer Slider Outer Slider	4
F2 	250mm	Inner Slider Inner Slider	4
G 		Handle Handle	2
H 	M4x19mm	Screw Screw	4
I 	8x30mm	Wooden dowel Wooden dowel	8
J 	6x31mm	Cam bolt Cam bolt	8
K 	15x11mm	Cam Lock Cam Lock	8
L 		Wedge Wedge	10
M 	3,5X14mm	Screw	10

Les quantités de composants indiquées ci-dessus sont nécessaires pour un assemblage correct.

Des pièces supplémentaires peuvent être incluses.

Las cantidades de tornillería indicadas anteriormente son necesarias para un montaje correcto.

Se pueden incluir piezas de ferretería adicionales.

Introduction pour un assemblage facile du système de tiroirs

Dis adieu au tracas de l'assemblage !

Nous comprenons que l'assemblage des tiroirs peut être la partie la plus longue et la plus fastidieuse de l'assemblage de tes nouveaux meubles. C'est pourquoi nous avons développé le système de tiroirs d'assemblage facile - pour rendre le processus plus facile !

Dovetail Verrouillage Traba

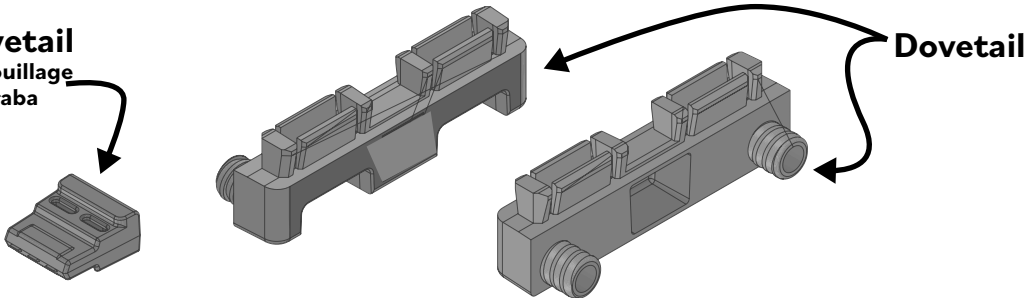

Pourquoi tu vas adorer notre système de tiroirs d'assemblage facile :

Rapide et facile : notre nouveau système de tiroir réduit considérablement le temps d'assemblage. Fais-le vite !

Effort minimal requis : Conçu pour être extrêmement simple, tu n'auras besoin que de peu ou pas d'outils pour effectuer le travail.

Construit pour durer : Solide et résistant, notre système garantit que tes tiroirs restent solides et fiables.

Préparons le scénario pour l'assemblage :

Step 1: Prépare-toi -

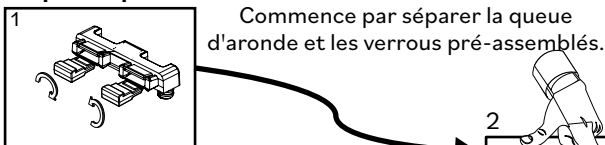

Step 2: Jonction -
Combine la queue d'aronde avec les côtés du tiroir comme indiqué sur l'illustration.

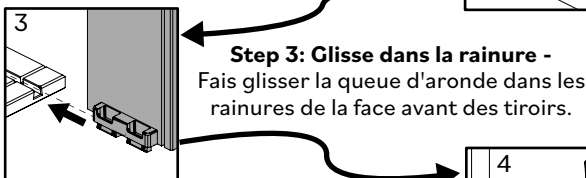
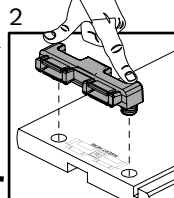

Step 4: Verrouillage -
Après avoir installé le fond du tiroir, verrouille la queue d'aronde à l'aide des loquets à queue d'aronde

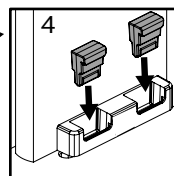

Attention : Lors des prochaines étapes, tu trouveras plus de détails pour t'aider durant l'assemblage.

Introducción al Sistema de Fácil Montaje de Cajones

¡Despídete de las complicaciones del montaje!

Entendemos que ensamblar cajones puede ser la parte más lenta y tediosa de ensamblar tus muebles nuevos. Es por eso que desarrollamos el Sistema de Cajones de Montaje Fácil, ¡para facilitar el proceso!

Por qué te encantará nuestro sistema de cajones fácil de montar:

Rápido y fácil : nuestros nuevos herrajes para cajones reducen significativamente el tiempo de montaje. ¡Hazlo rápido!

Mínimo esfuerzo requerido : Diseñado para ser muy simple, necesitarás pocas o ninguna herramienta para hacer el trabajo.

Fabricado para durar : Fuerte y resistente, nuestro sistema garantiza que tus cajones permanezcan sólidos y confiables.

Preparamos el espacio para el montaje:

Step 1: ¡Prepárate! -

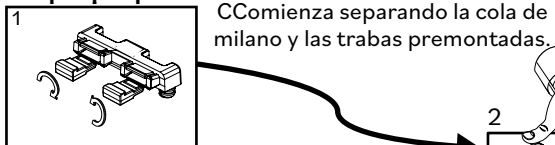

Step 2: Unión -
Combina la cola de milano con los lados del cajón, como se muestra en la ilustración.

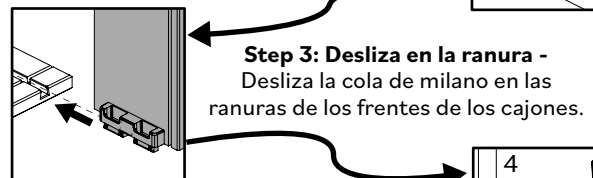
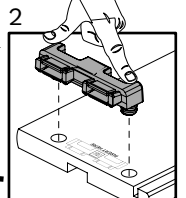

Step 4: Traba -
Después de colocar la parte inferior del cajón, bloquea la cola de milano usando las trabas de cola de milano.

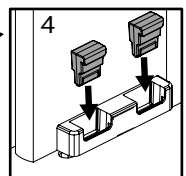

Atención : En los próximos pasos, hay más detalles para ayudarte con el montaje.

Étape / Paso 1

(FR)

Préparez les Dovetails (A) en retirant les Dovetail Locks (B) des Dovetails (A).

(ES)

Prepare los Dovetails (A) quitando los Dovetail Locks (B) de los Dovetails (A).

1st

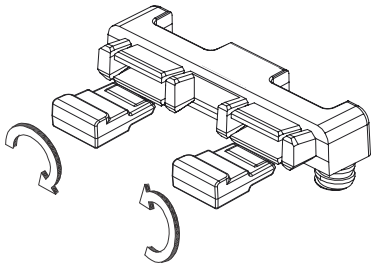

2nd

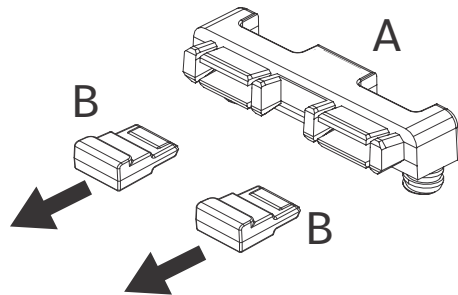

Étape / Paso 2

(FR)

Insérez les Dovetails (A) en place sur les Côtés Droits du Tiroir (11) et les Côtés Gauches du Tiroir (12). Appuyez sur les Dovetails jusqu'à ce qu'ils soient complètement fixés. Utilisez un marteau si nécessaire.

(ES)

Coloque los Dovetails (A) en los Laterales Derecho (11) e Izquierdo (12) del Cajón. Presione hasta que estén completamente fijados. Use un martillo si es necesario.

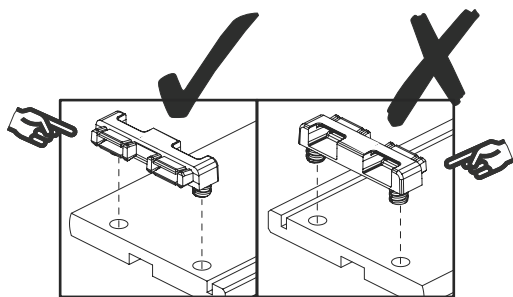

Appuyez sur la pièce jusqu'à ce qu'elle soit complètement fixée.

Presione la pieza hasta que esté completamente fijada.

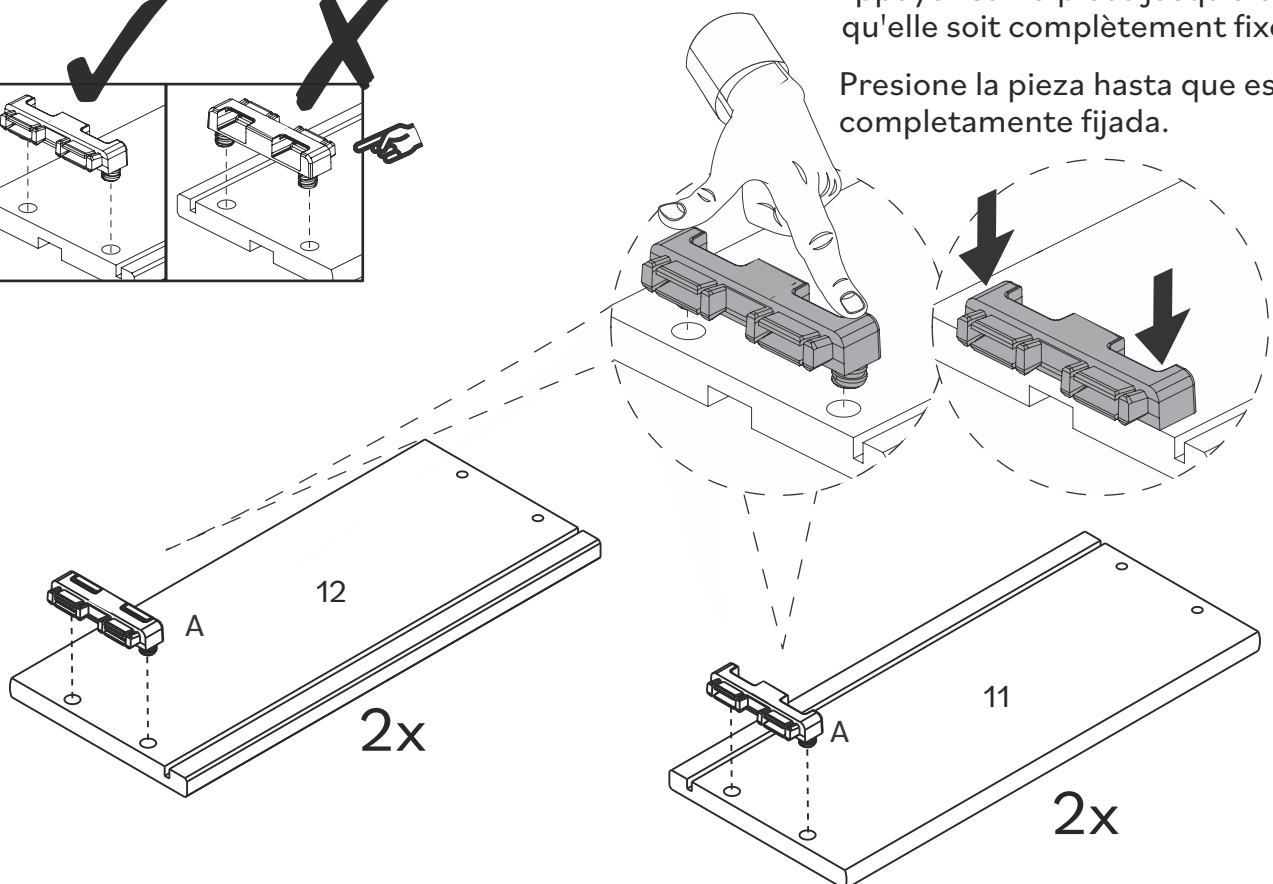

Étape / Paso 3

(FR)

Faites glisser le Dovetail (A) du Panneau Droit du Tiroir (11) et du Panneau Gauche du Tiroir (12) dans les rainures de la Façade du Tiroir (8).

(ES)

Deslice el Dovetail (A) del Panel Derecho (11) y del Panel Izquierdo (12) en las ranuras del Frente del Cajón (8).

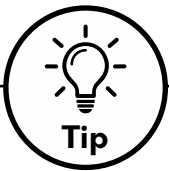
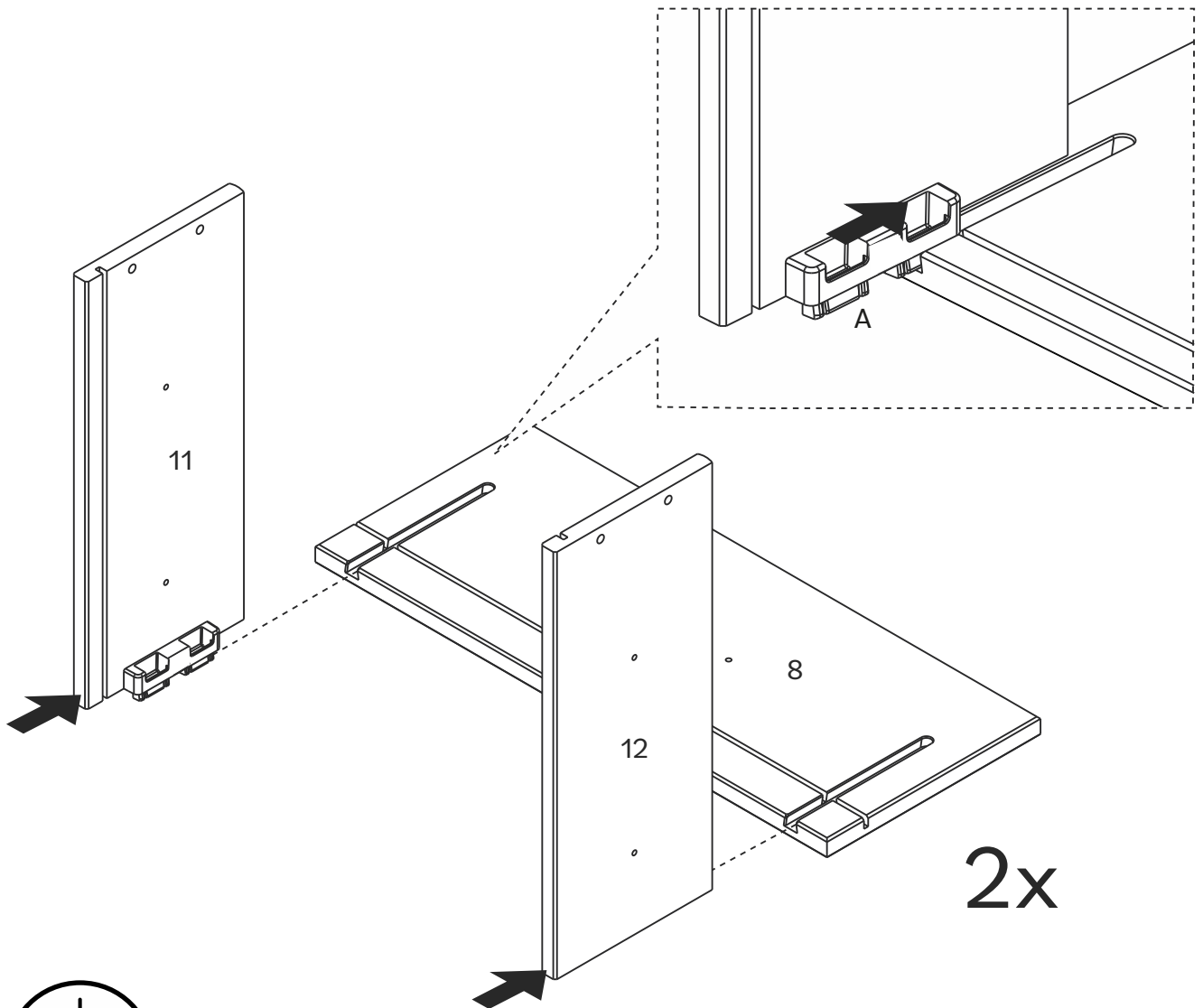

Tip

Pour que ton produit conserve son meilleur aspect et sans rayures, essaie de le monter sur une surface souple telle qu'un tapis ou une couverture. Cela permet d'éviter les rayures accidentelles et de garder tes meubles en bon état !

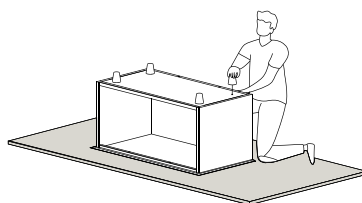

Para mantener su producto con el mejor aspecto y sin arañazos, pruebe a montarlo sobre una superficie blanda, como una alfombra o una manta. Así evitará arañazos accidentales y mantendrá sus muebles en perfecto estado.

Étape / Paso 4



(FR)

Faites glisser le Fond du Tiroir (10) entre les rainures du Côté Droit du Tiroir (11) et du Côté Gauche du Tiroir (12) en l'insérant dans la Façade du Tiroir (8).

(ES)

Deslice el Fondo del Cajón (10) entre las ranuras de los Laterales Derecho (11) e Izquierdo (12) insertándolo en el Frente del Cajón (8).

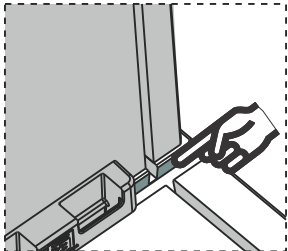

Alignez les rainures sur les côtés et le devant du tiroir pour recevoir le fond du tiroir

Alinee las ranuras en los lados y el frente del cajón para recibir la parte inferior del cajón.

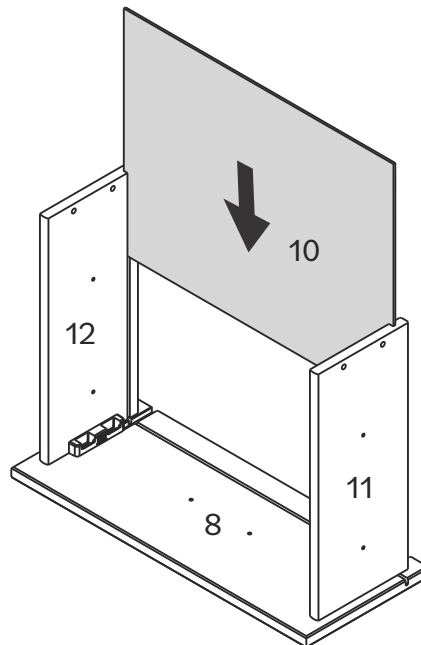

2x

Étape / Paso 5



(FR)

Pour sécuriser les côtés du tiroir, insérez les Dovetail Locks (B) dans les Dovetails (A). Utilisez un marteau si nécessaire.

(ES)

Para asegurar los laterales del cajón, inserte los Dovetail Locks (B) en los Dovetails (A). Use un martillo si es necesario.

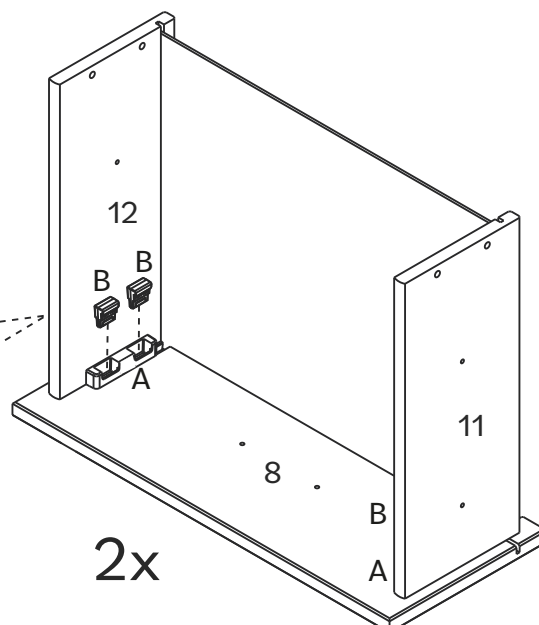
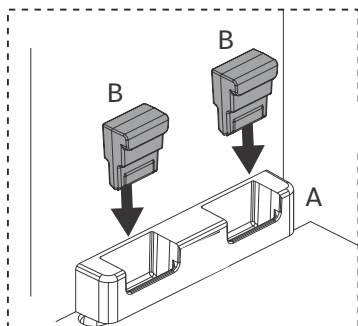

2x

Une fois cette étape terminée, votre produit devrait ressembler à ceci:

Una vez completado este paso, su producto debería verse así:

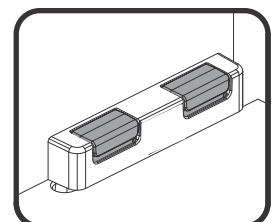

Étape / Paso 6



(FR)

Fixez le Fond du tiroir (10) à l'Arrière du tiroir (9) et sécurisez à l'aide de la Vis en Plastique (C), vous pouvez l'insérer à la main ou à l'aide d'un marteau.

(ES)

Fije el Fondo del Cajón (10) a la Parte Trasera del Cajón (9) y asegure con el Tornillo de Plástico (C), puede insertarlo a mano o con un martillo.

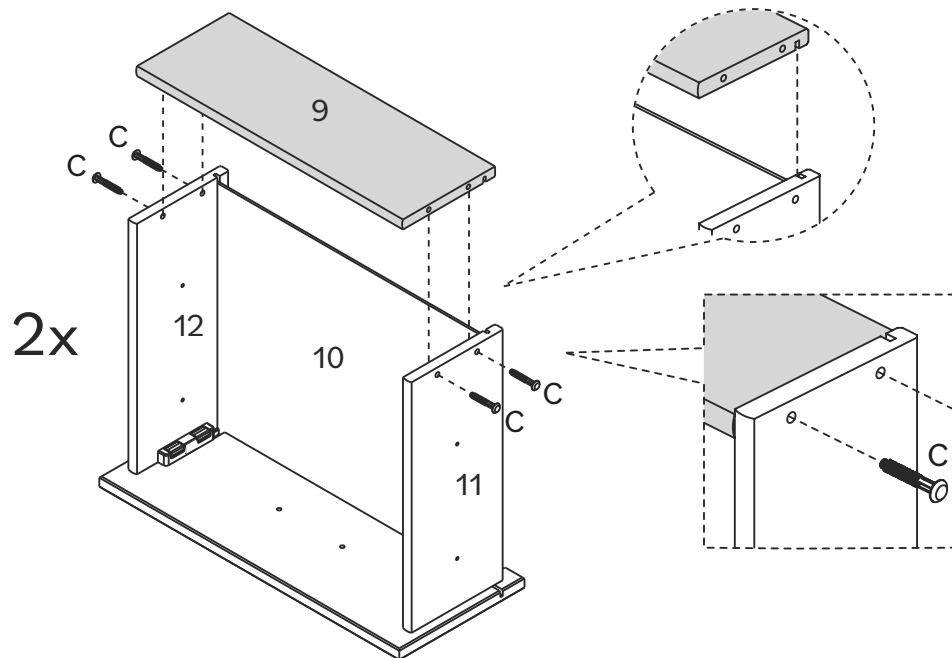

Étape / Paso 7

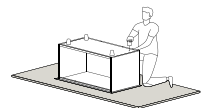

(FR)

Fixez les Glissières Intérieures (F2) aux Côtés Droits du tiroir (11) et aux Côtés Gauches du tiroir (12) en utilisant les Vis (D) et un tournevis cruciforme.

(ES)

Fije las Correderas Interiores (F2) a los Laterales Derecho (11) e Izquierdo (12) utilizando los Tornillos (D) y un destornillador Phillips.

Séparez les pièces F1 et F2 en appuyant sur le verrou

Separate las piezas F1 y F2 presionando el seguro.

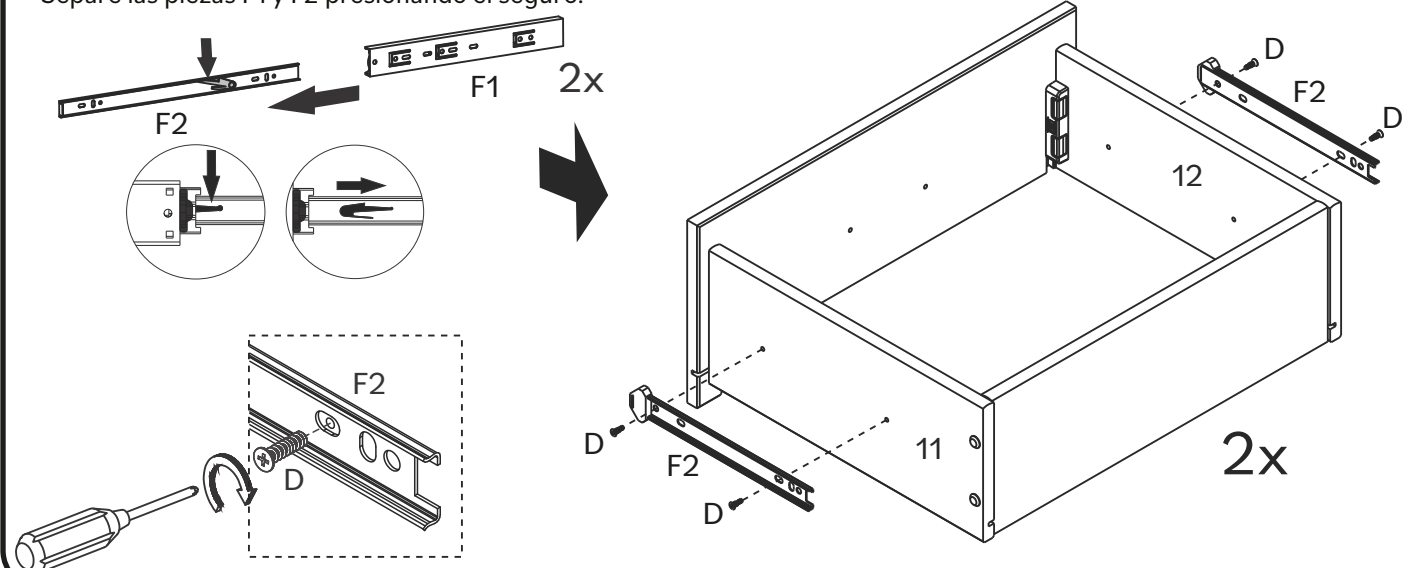

Étape / Paso 8

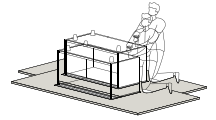

(FR)

Utilisez les Vis (H) et un tournevis cruciforme pour fixer les Poignées (G) aux Façades des Tiroirs (8).

(ES)

Utilice los Tornillos (H) y un destornillador Phillips para fijar las Manijas (G) a los Frontes de los Cajones (8).

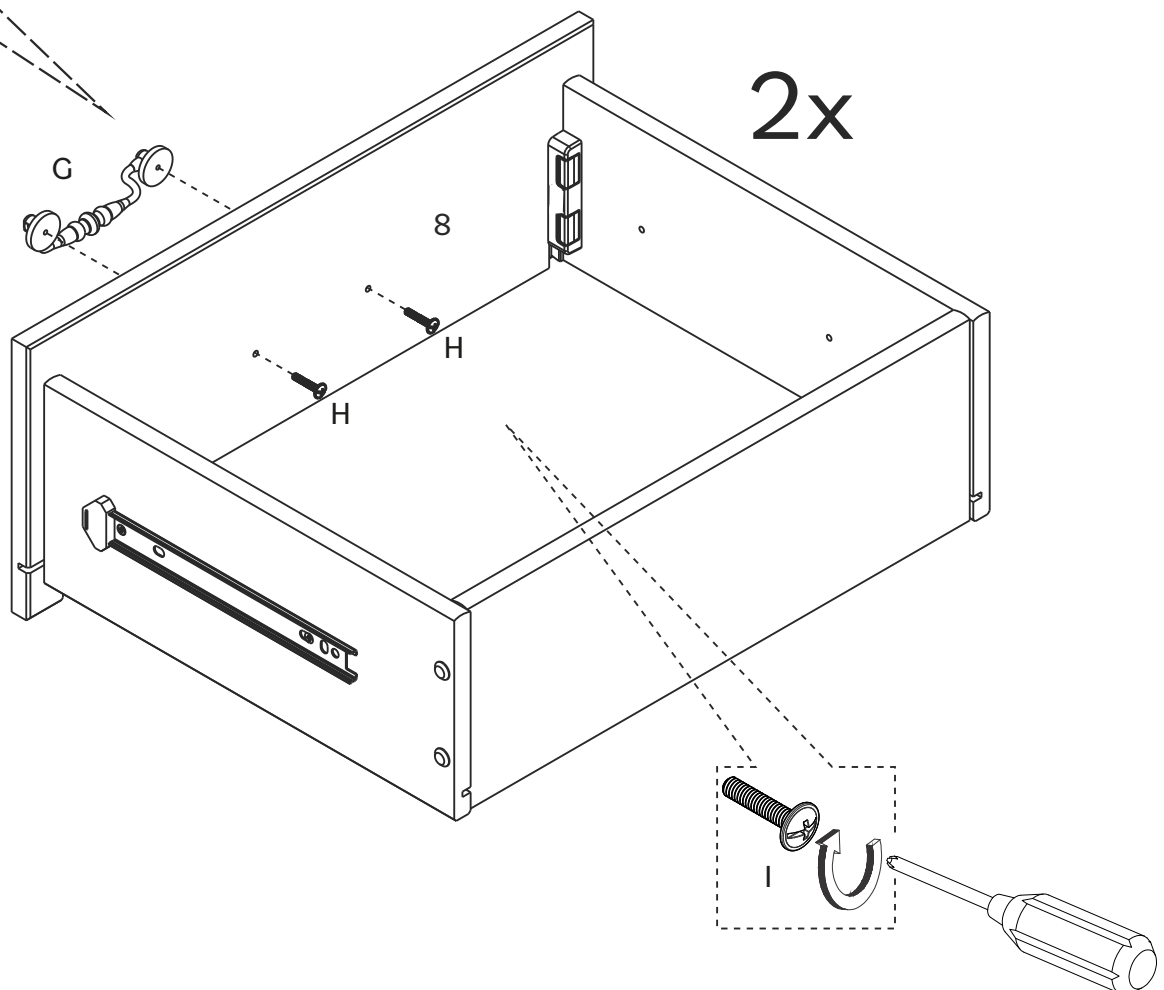
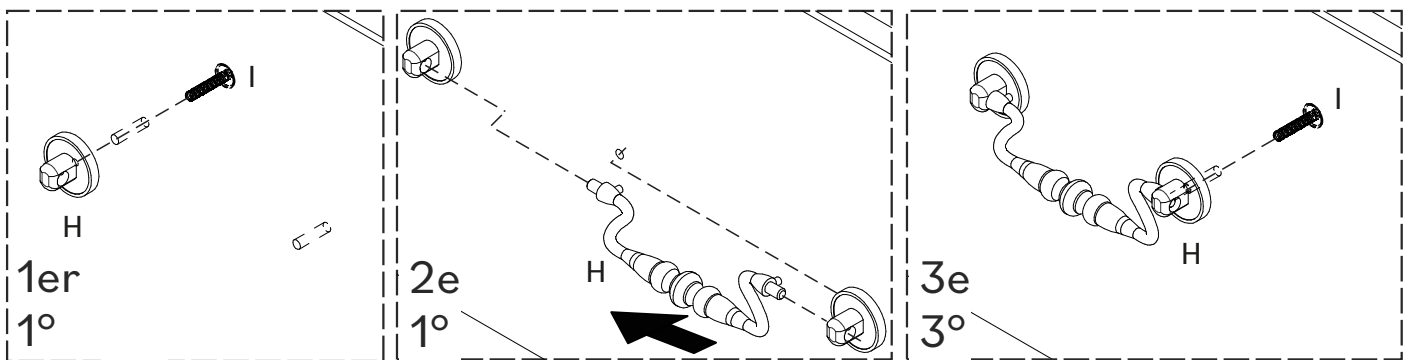
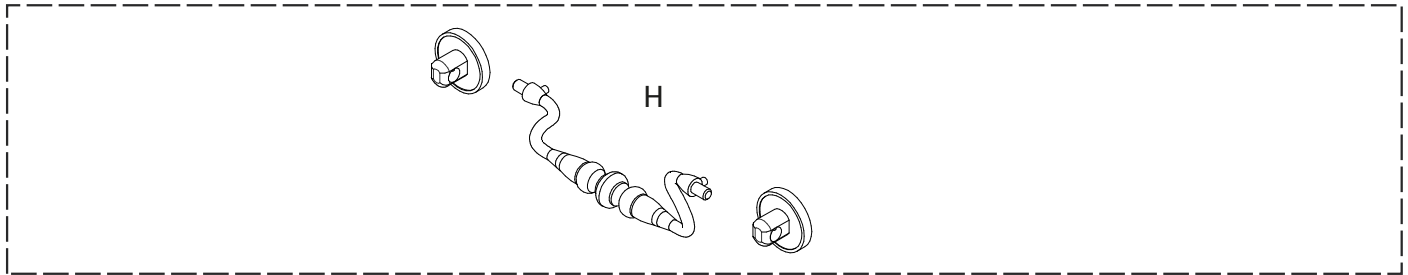

Étape / Paso 9



(FR)

Insérez les Chevilles en Bois (I) dans le Panneau Gauche (1), le Panneau Droit (2), la Traverse Avant (4) et la Traverse Arrière (5).

(ES)

Inserte las Espigas (I) en el Panel Izquierdo (1), Panel Derecho (2), Travesaño Frontal (4) y Travesaño Trasero (5).

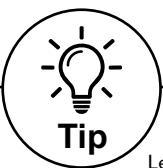
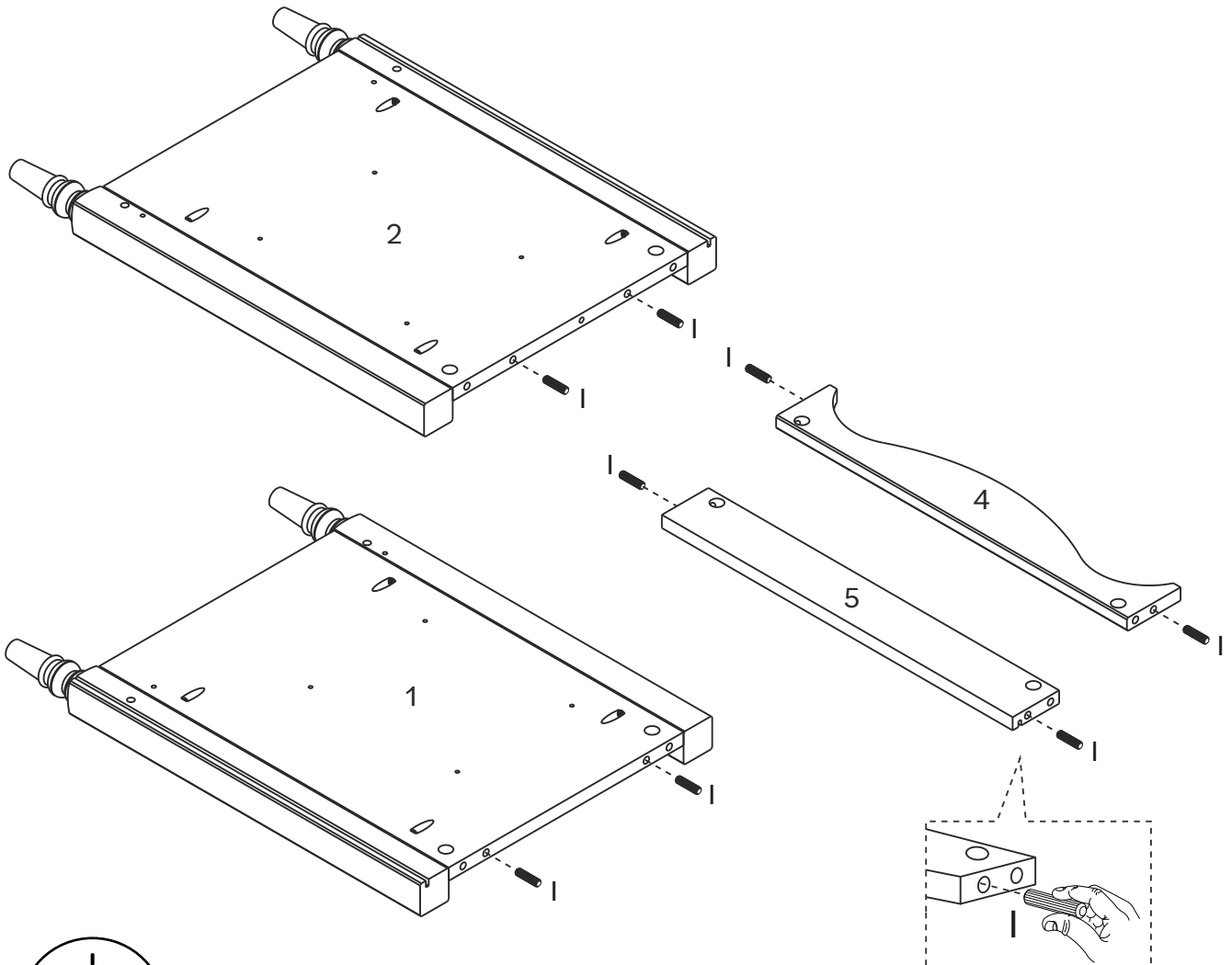

Cheville en bois

Les chevilles sont essentielles lors de l'assemblage de meubles pour créer des connexions solides et précises. Elles garantissent l'intégrité structurelle, empêchent les déplacements et simplifient l'alignement, ce qui permet d'obtenir des meubles plus résistants et plus durables. suis ces étapes :

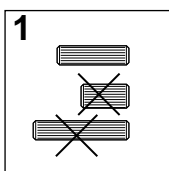

- 1: Sélectionne la taille de cheville appropriée en fonction de l'étape.
1: Seleccione el tamaño de espiga adecuado según el paso.

Espiga de madera

Las espigas son esenciales en el montaje de muebles para crear uniones fuertes y precisas. Garantizan la integridad estructural, evitan el desplazamiento y simplifican la alineación, lo que se traduce en muebles más resistentes y duraderos.

Sigue estos pasos:

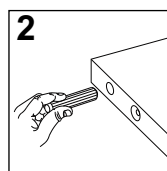

- 2: Insère dans le trou indiqué et appuie fermement pour assurer un positionnement correct.
2: Insértela en el orificio indicado y presione firmemente para asegurar su correcta colocación.

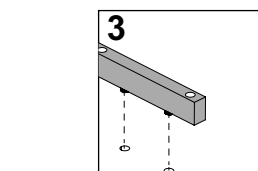
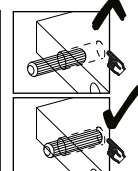

- 3: Alinee la cheville avec la pièce correspondante et enfonce-la jusqu'à ce qu'elle soit ferme.
3: Alinee el pasador con la pieza correspondiente y presiónelo hasta que encaje.

Étape / Paso 10

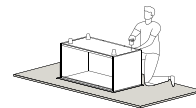

(FR)

Fixez les Goujons (J) au Panneau Gauche (1), au Panneau Droit (2) et au Panneau Supérieur (3).

(ES)

Fije los Conectores (J) al Panel Izquierdo (1), Panel Derecho (2) y Panel Superior (3).

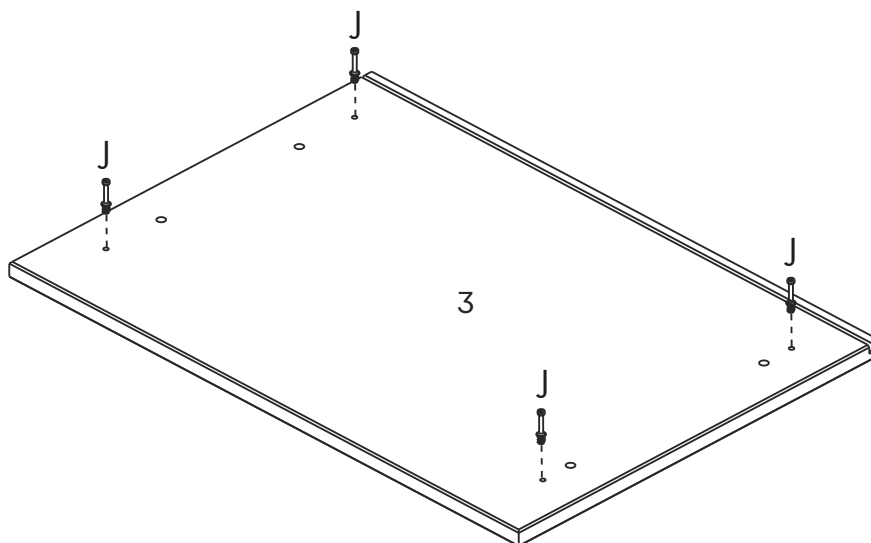
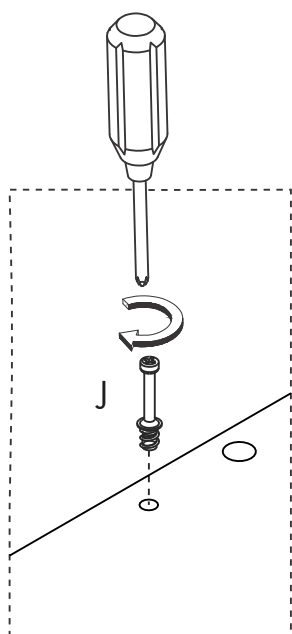
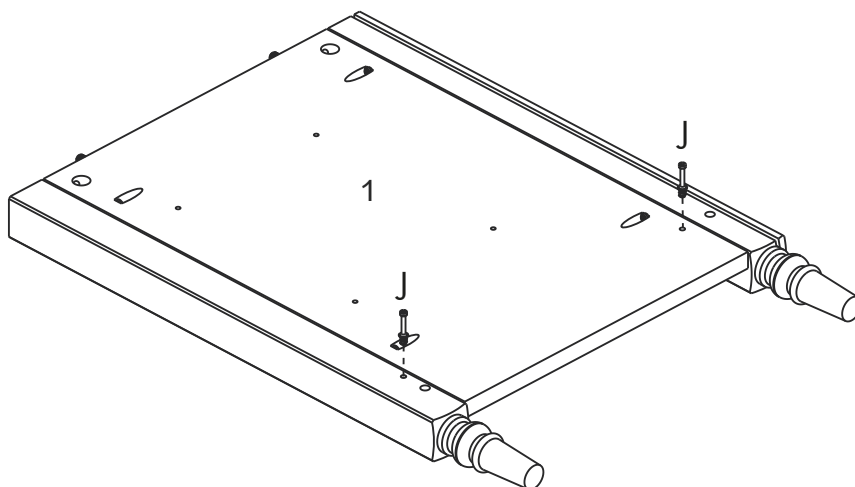
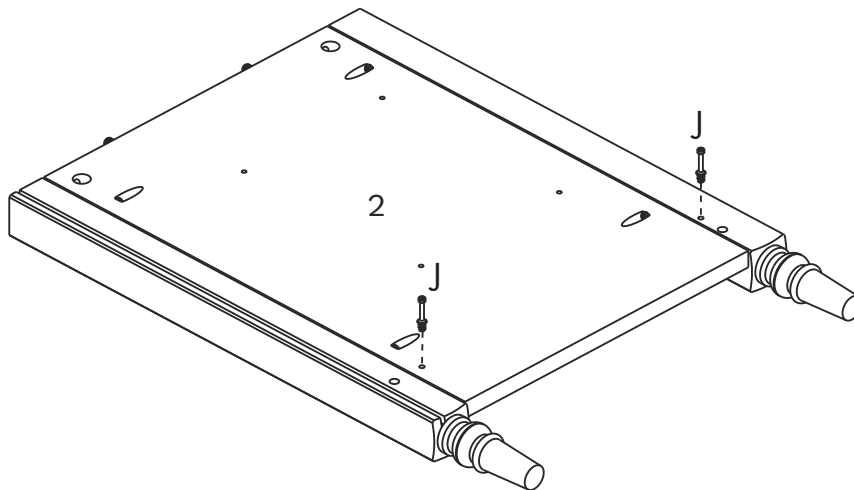

Étape / Paso 11



(FR)

Fixez la Glissière Extérieure (F1) au Panneau Gauche (1) et au Panneau Droit (2) en utilisant les Vis (E) et un tournevis cruciforme.

(ES)

Fije la Corredera Exterior (F1) al Panel Izquierdo (1) y al Panel Derecho (2) utilizando los Tornillos (E) y un destornillador Phillips

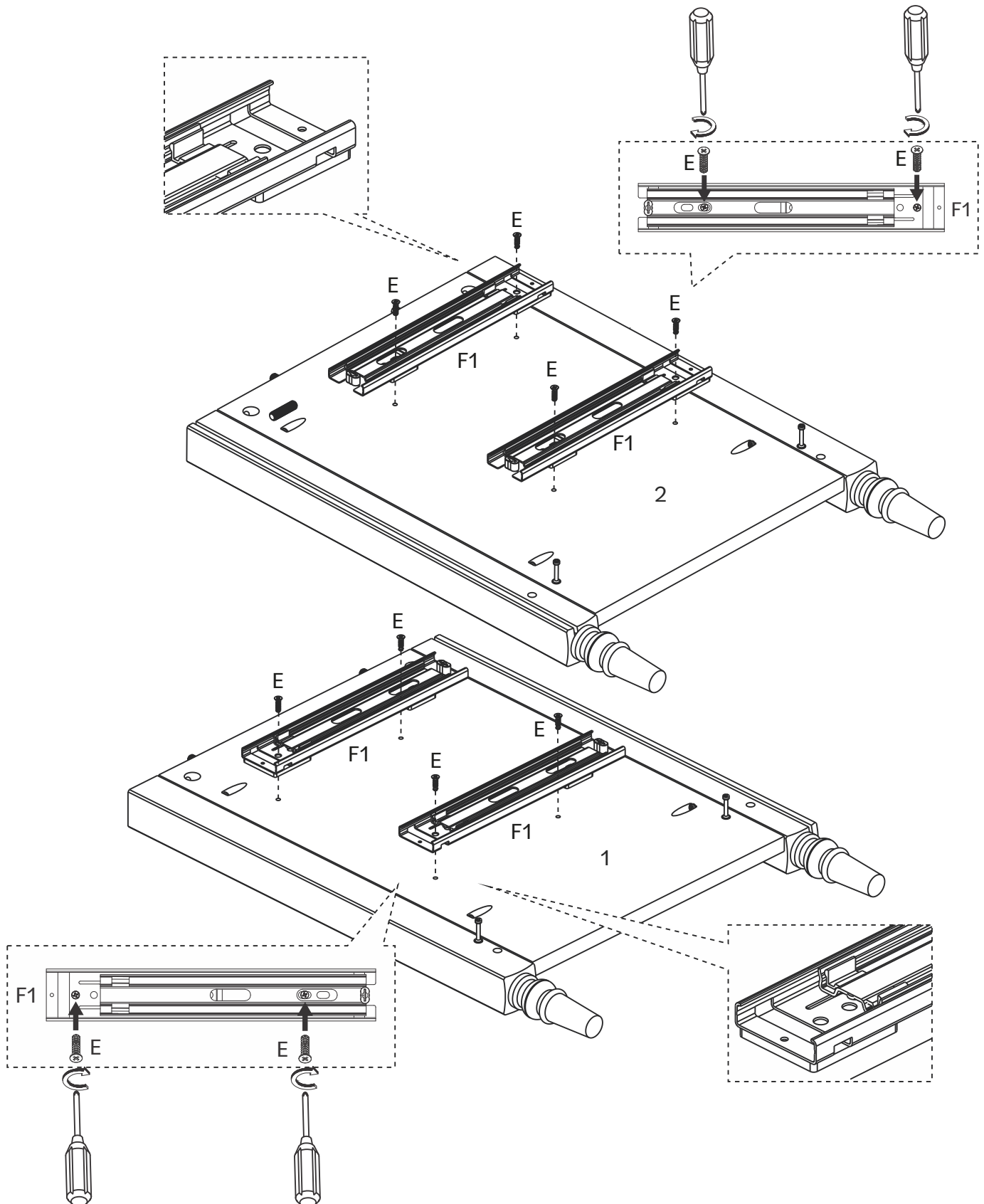

Étape / Paso 12

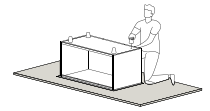

(FR)

Fixez la Traverse Avant (4) et la Traverse Arrière (5) au Panneau Gauche (1) en utilisant le Boitier (K) et un tournevis cruciforme.

(ES)

Fije el Travesaño Frontal (4) y el Travesaño Trasero (5) al Panel Izquierdo (1) utilizando la Traba (K) y un destornillador Phillips.

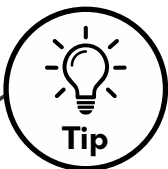
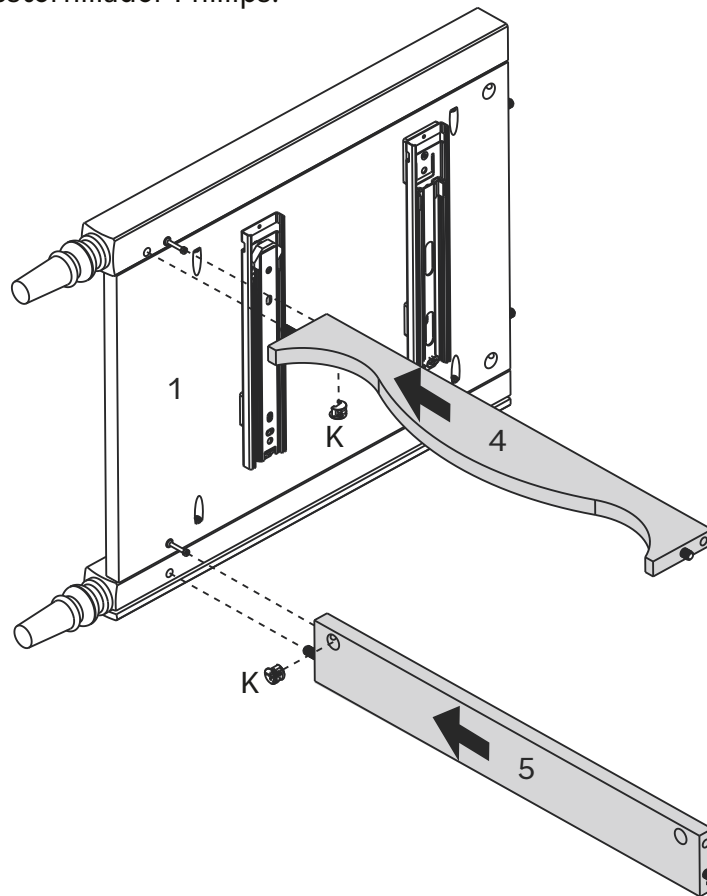

Tip

Goujon de Assemblage

Goujon de Assemblage permet de joindre deux pièces en toute sécurité. Suis ces étapes simples.

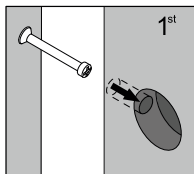

1: Insère le Goujon dans les orifices du côté plat. Ne serre pas trop!

1: Coloca el Conector en los orificios del lado plano. ¡No aprietes demasiado!

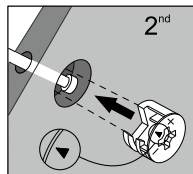

2: Joins les pièces en bois. Les Goujons entrent dans les orifices qui ont des trous sur les côtés, tu dois pouvoir voir les Goujons à travers ceux-ci. Après avoir installé les pièces, insère le Boitiers dans les orifices latéraux

2: Una las piezas de madera. Los Conectores entran en las piezas que tienen orificios en los lados, por lo que deberías poder ver los Conectores a través de ellos. Después de encajar las piezas, inserta la traba en los orificios laterales.

Conector

Los Conector ayudan a unir de forma segura dos piezas. Sigue estas fáciles etapas.

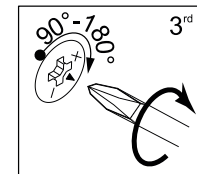

3: Sur la partie arrière du boitier, il aura la forme d'un « C ». Insère le boitier de manière à ce que l'ouverture « C » s'emboîte à la goujon. Serre-la avec le tournevis.
3: La parte posterior de la traba tendrá la forma de "C". Inserta el tambor de modo que la abertura de la "C" encaje en el Conector. Apriétalo con un destornillador.

Étape / Paso 13



(FR)

Assemblez le Panneau Droit (2) à la Traverse Avant (4) et à la Traverse Arrière (5) en utilisant le Boitier (K) et un tournevis cruciforme.

(ES)

Ensamble el Panel Derecho (2) al Travesaño Frontal (4) y al Travesaño Trasero (5) utilizando la Traba (K) y un destornillador Phillips.

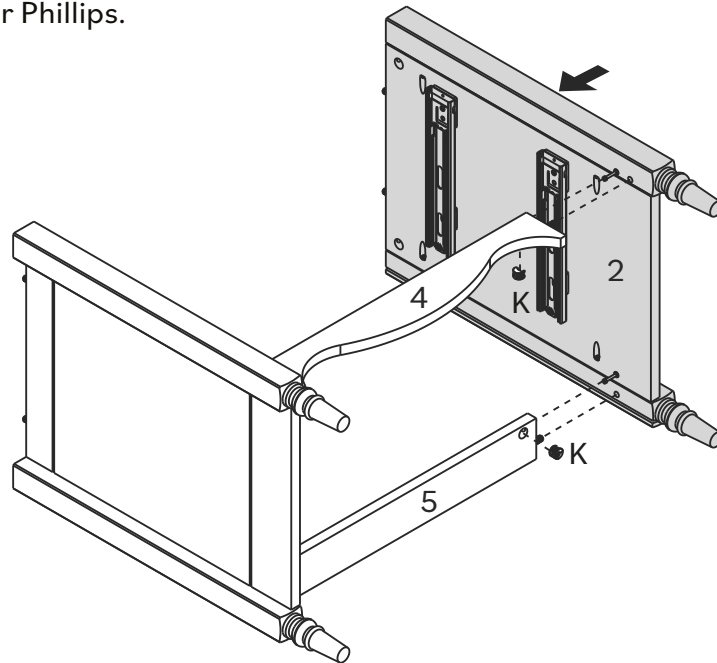
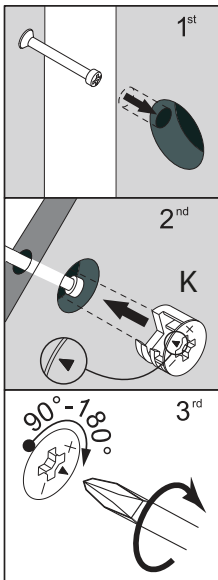

Étape / Paso 14



(FR) Faites glisser le Panneau Arrière (6) dans les rainures du Panneau Gauche (1) et du Panneau Droit (2) en l'insérant dans la Traverse Arrière (5).

(ES) Deslice el Panel Trasero (6) en las ranuras del Panel Izquierdo (1) y del Panel Derecho (2) insertándolo en el Travesaño Trasero (5).

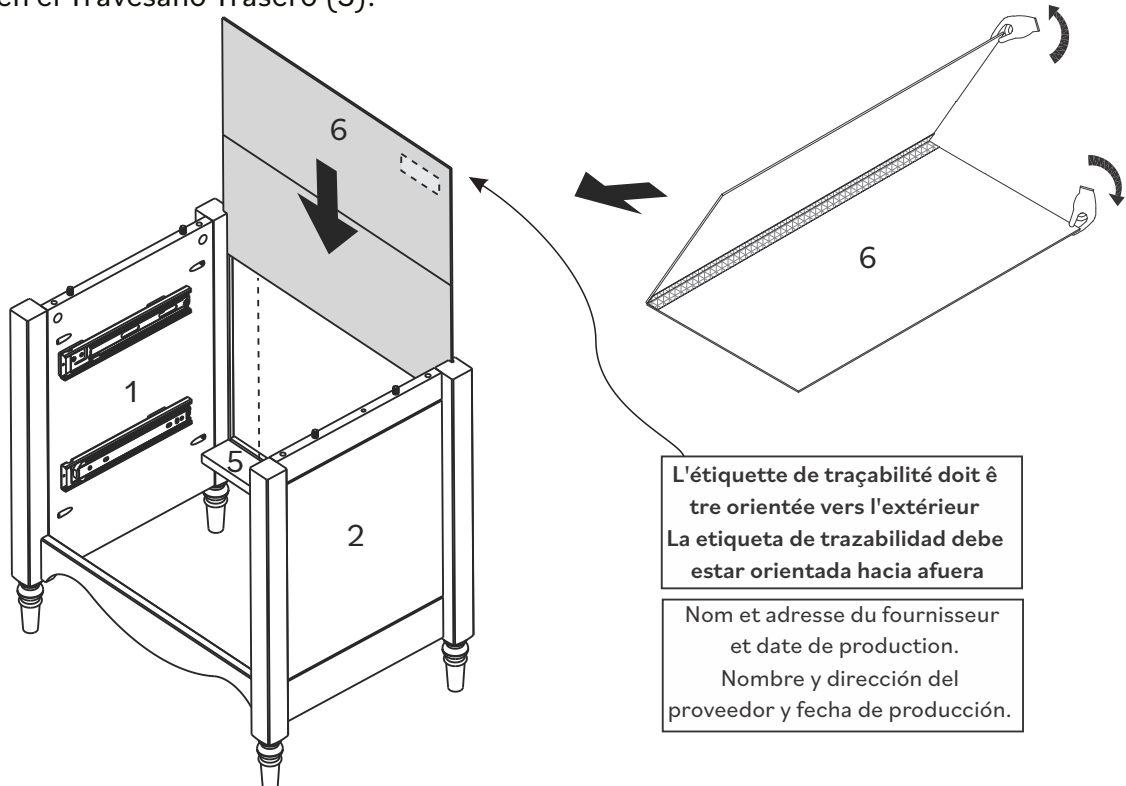

Étape / Paso 15



(FR)

Fixez le Panneau Supérieur (3) au Panneau Gauche (1) et au Panneau Droit (2) en utilisant les Boitiers (K) et un tournevis cruciforme.

(ES)

Fije el Panel Superior (3) al Panel Izquierdo (1) y al Panel Derecho (2) utilizando las Trabas (K) y un destornillador Phillips.

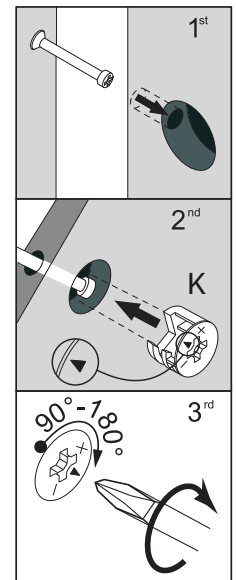
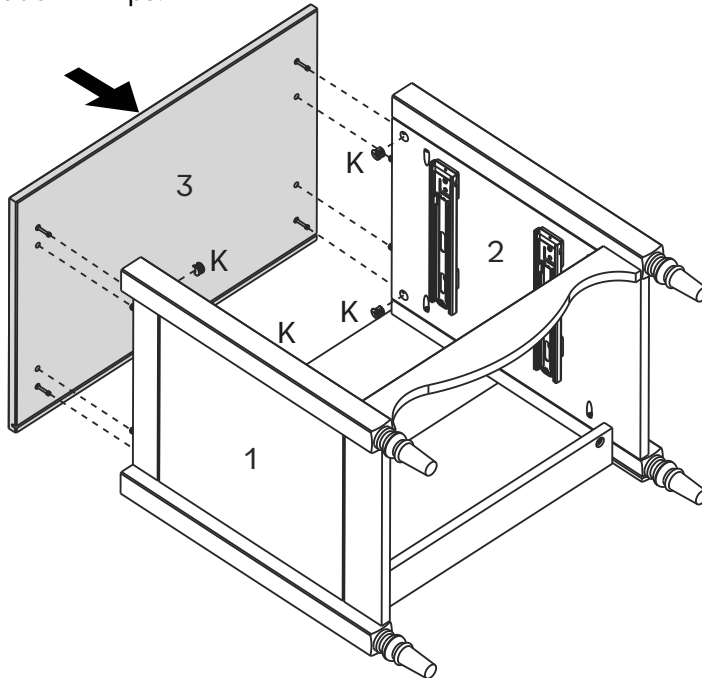

Étape / Paso 16

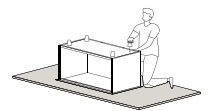

(FR)

Fixez le Panneau Arrière (6) en insérant la Cale (L) et la vis (M) entre le panneau et les rainures. Utilisez un tournevis Phillips.

(ES)

Asegure el Panel Trasero (6) colocando la Cuña (L) y el tornillo (M) entre el panel y las ranuras. Use un destornillador Phillips.

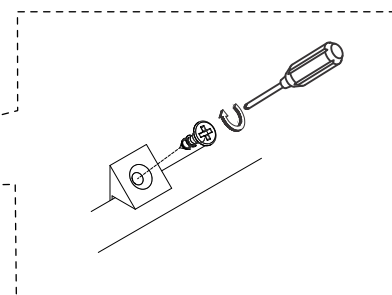
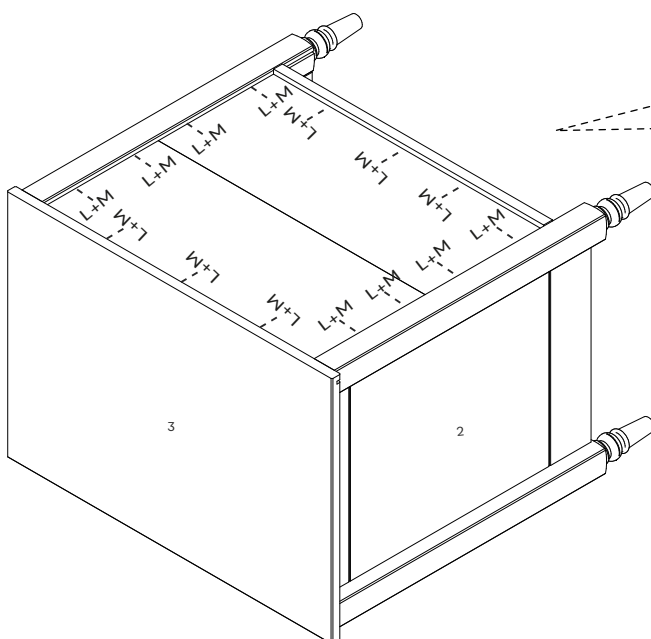

Étape / Paso 17

(FR)

Placez les tiroirs un par un en utilisant les glissières, veillez à bien les positionner en alignant la Glissière Extérieure et la Glissière Intérieure.

(ES)

Coloque los cajones uno por uno usando las correderas, asegurándose de alinearlos correctamente.

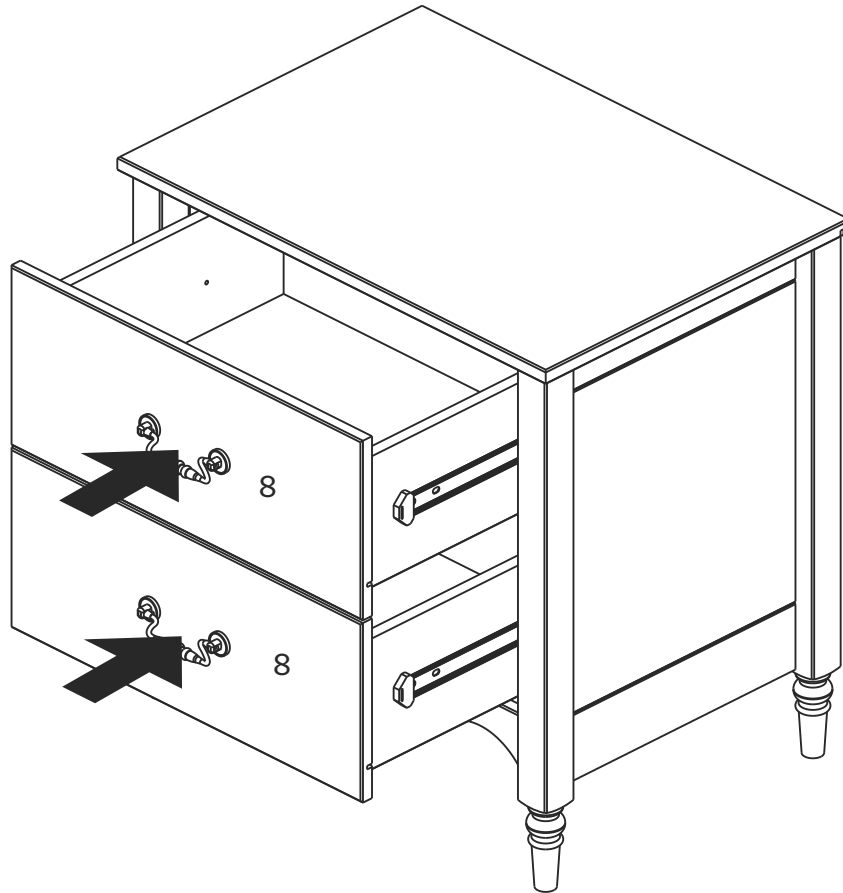

Tip

Insérez correctement le tiroir de votre armoire

Alignez les glissières extérieure et intérieure et poussez légèrement le tiroir à l'intérieur du meuble. Une fois la connexion établie, poussez le tiroir jusqu'à ce qu'il soit bien en place. Le glissement peut être délicat au début, mais il s'améliore une fois la connexion établie.

Inserte el cajón de su gabinete correctamente

Alinee las correderas exterior e interior y empuje el cajón ligeramente dentro de la unidad. Una vez que sienta la conexión, empujelo completamente hasta que encaje en su lugar. Puede que al principio no se deslice con suavidad, pero mejora una vez que esté completamente conectado..

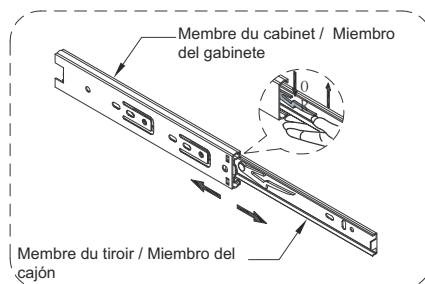

Retrait du tiroir

Il y a un levier blanc dans chaque glissière. Pour retirer les tiroirs, tirez le tiroir jusqu'à ce que vous voyiez le levier. Poussez un levier vers le haut et l'autre vers le bas, tout en poussant, tirez le tiroir vers l'extérieur.

Extracción del cajón

Hay una palanca blanca en cada riel. Para quitar los cajones, tire del cajón hasta que vea la palanca. Empuje una palanca hacia arriba y la otra hacia abajo, y mientras empuja, saque el cajón.

À démonter / Para desmontar



(FR)

Si le démontage est nécessaire, retirez le Dovetail Lock (B) à l'aide d'un tournevis à tête plate.

(ES)

Si es necesario desmontar, retire el Dovetail Lock (B) con un destornillador plano.

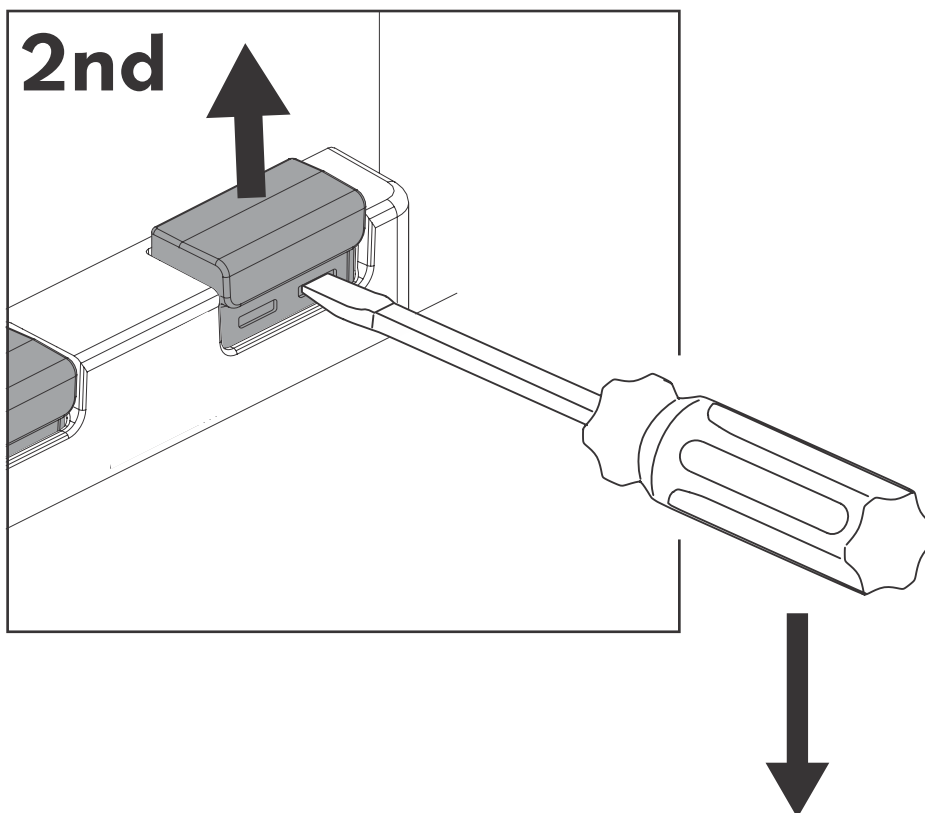
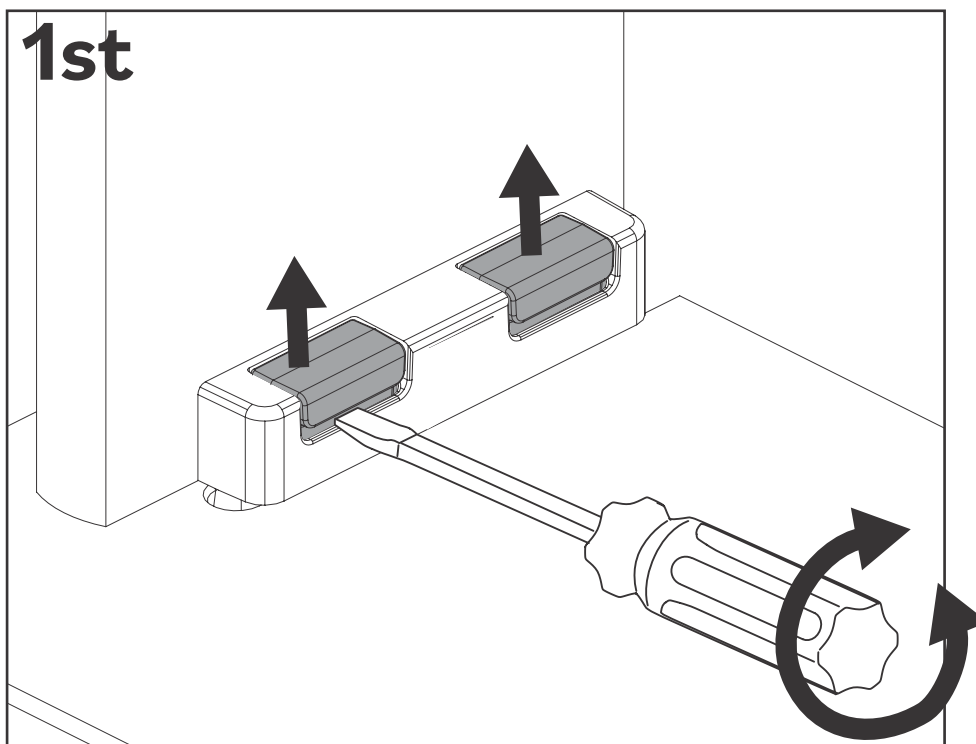

Tu as réussi ! Profite de ton nouveau Table de nuit!

¡Lo ha conseguido! ¡Disfrute de su nueva
¡Mesita de noche

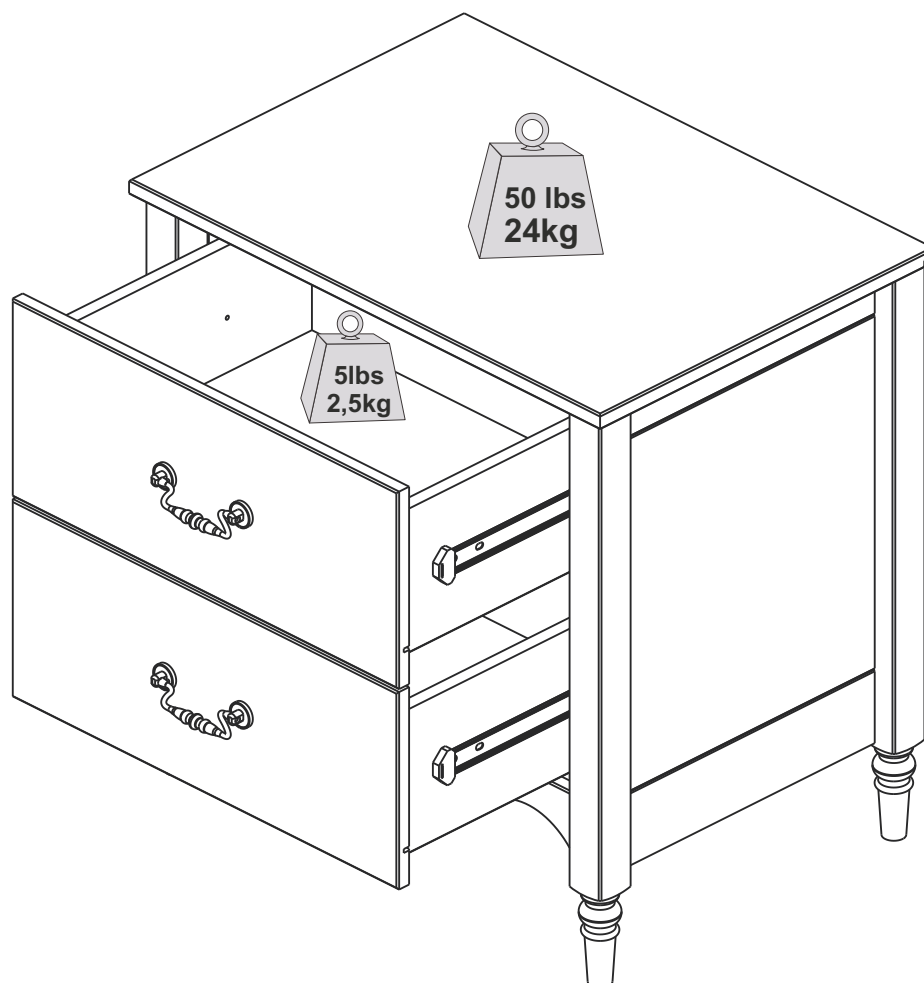

Bravo pour ton nouveau meuble !

¡Enhorabuena por sus nuevos muebles!