

Instruction Sheet

Step 3- Assembly

- Place slats (5) between left side rail (3) and right side rails (4). SEE FIGURE 4
- Align holes on cross rails (5) with threaded holes on side rails (3 &4) cleat.
- Secure cross rails (5) to a cleat on side rails (3 & 4) with screw (12) and flat metal washer (11).
- Use Allen wrench (13).

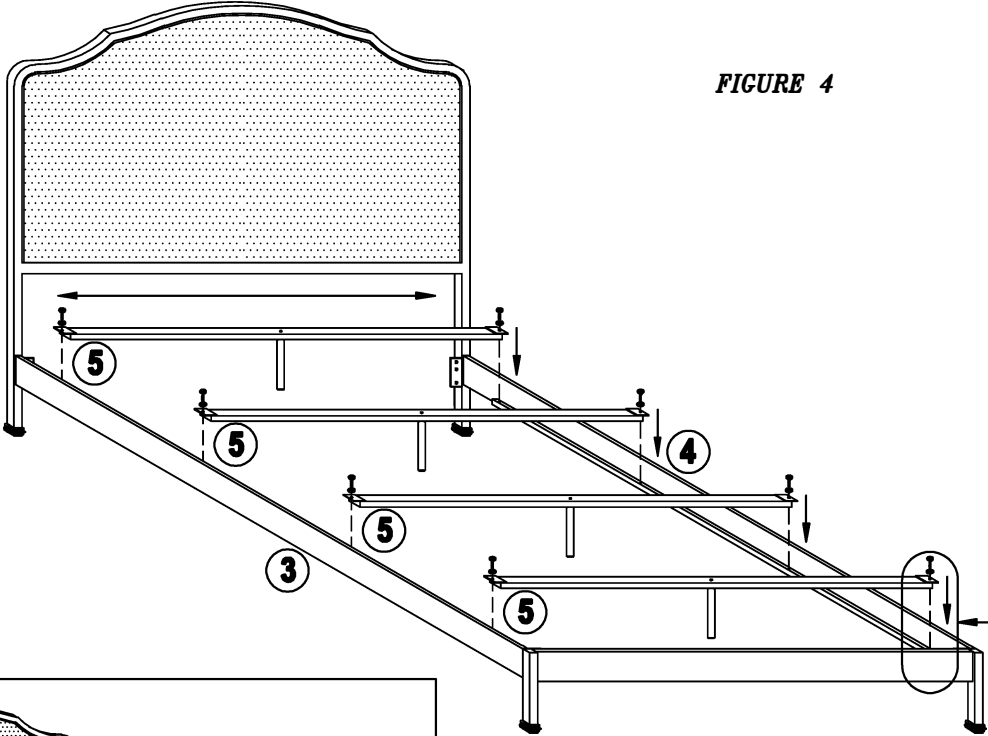

FIGURE 4

