













Read this instruction carefully. See hardware and furniture part list for guidance. Be sure all parts are complete, before you assemble. Place all wooden furniture parts on a clean and flat soft surface to prevent from being scratched. Follow the figure to start assembling.

**CAUTIONS :** 1. Do not FULLY - TIGHTEN the nut or nut bolt until all nut or bolt is ready assembled.  
 2. Do not OVER - TIGHTEN the nut or bolt to avoid causing damages to the thread.  
 3. Keep all hardware parts out of reach of children.

**NOTE :** THE LIST AND QUANTITY SHOWN ARE FOR 1 UNIT ASSEMBLY.  
 Tool needed : Screwdriver (not provider).

PART LIST			
ITEM	DESCRIPTION	BOX	QTY
A	HEADBOARD	1	1 PC
B	HEADBOARD LEG	1	2 PCS
C	HEADBOARD SUPPORT WOOD	1	2 PCS
D	HEADBOARD SUPPORT RAIL	1	1 PC
E	FOOTBOARD	2	1 PC
F	SIDE RAIL	2	2 PCS
G	CENTER RAIL	2	1 PC
H	CENTER SUPPORT LEG	2	3 PCS
I	BED SLAT	3	1 SET
J	BED LEG	2	4 PCS

HARDWARE LIST (BOX : 2)		
ITEM	DESCRIPTION	QTY
1	JCBC BOLT M6 x 20mm 	16 PCS
2	JCBB BOLT M8 x 50mm 	12 PCS
3	M6 FLAT WASHER 	16 PCS
4	M6 SPRING WASHER 	16 PCS
5	M8 FLAT WASHER 	16 PCS
6	M8 SPRING WASHER 	16 PCS
7	5/16" HEX NUT 	4 PCS
8	LB 001 CONNER BRACKET 	4 PCS
9	SPANNER 13mm 	1 PC
10	WOOD SCREW M4 x 38mm 	9 PCS
11	WOOD SCREW M4 x 20mm 	2 PCS
12	M4 ALLEN KEY (BALL SHAPE) 	1 PC
13	M5 ALLEN KEY (BALL SHAPE) 	1 PC

## STEP 1

Take out HEADBOARD LEG (B) & HEADBOARD SUPPORT WOOD (C) & HEADBOARD SUPPORT RAIL (D) for the HEADBOARD BACK (A).

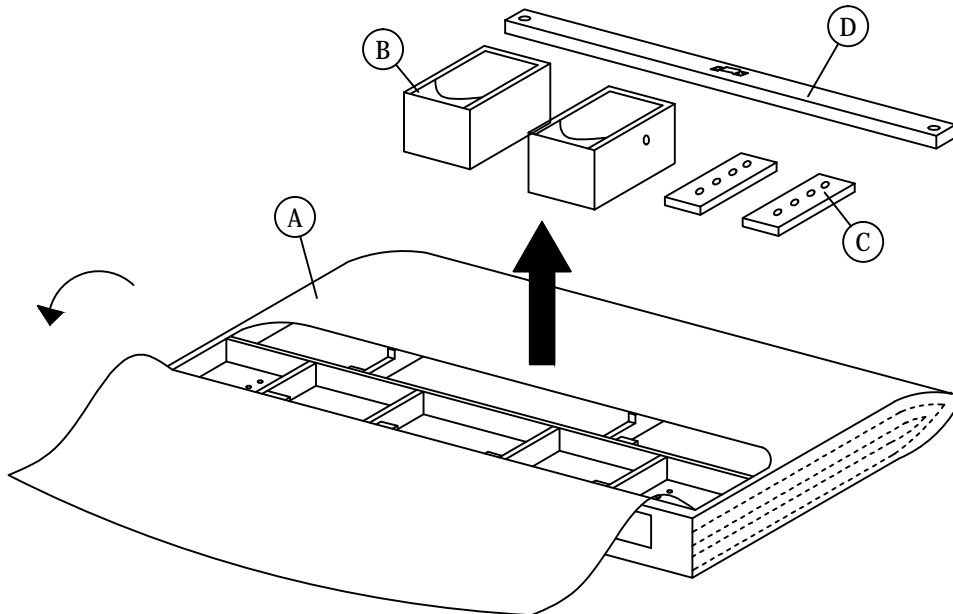

## STEP 2

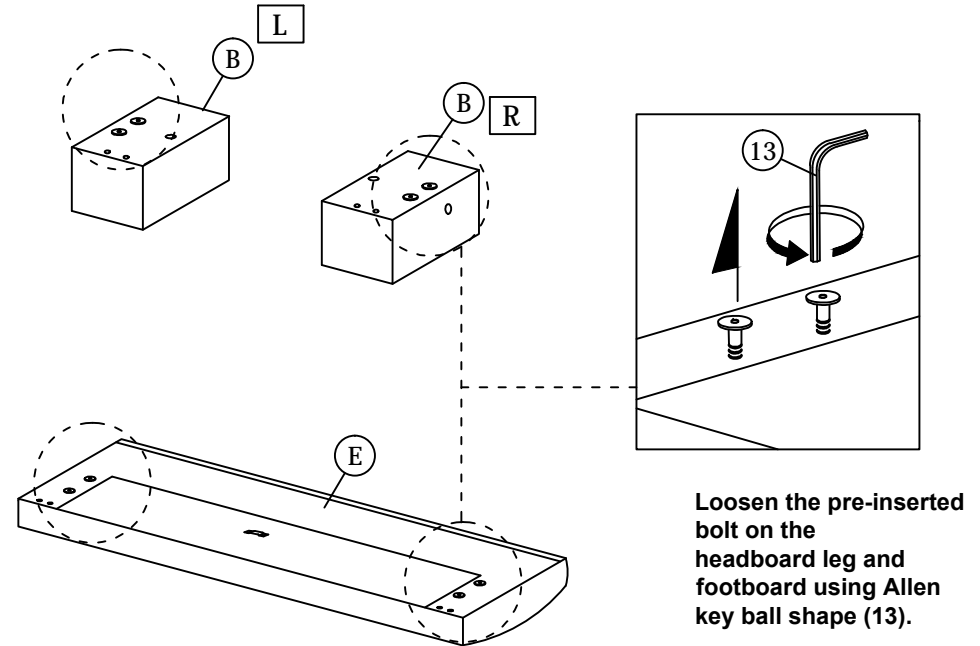

# ASSEMBLY INSTRUCTIONS

STEP 3

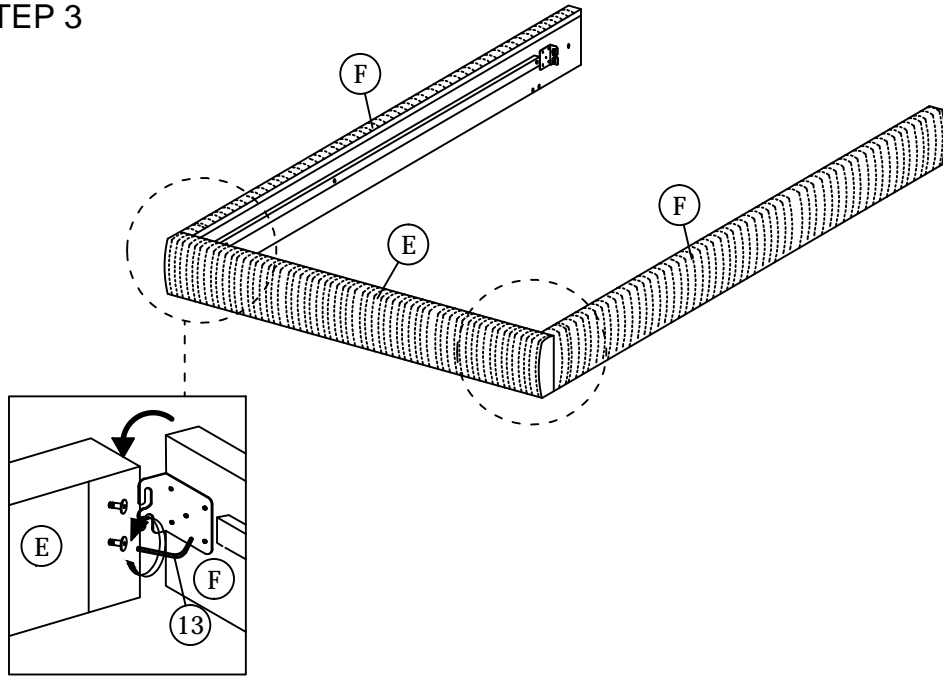

STEP 4

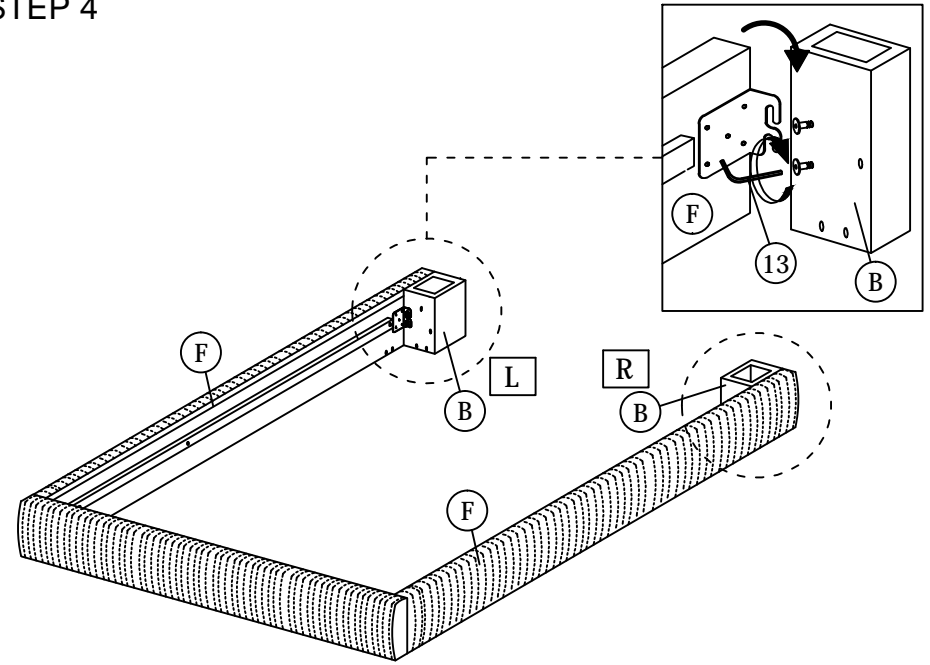

STEP 5

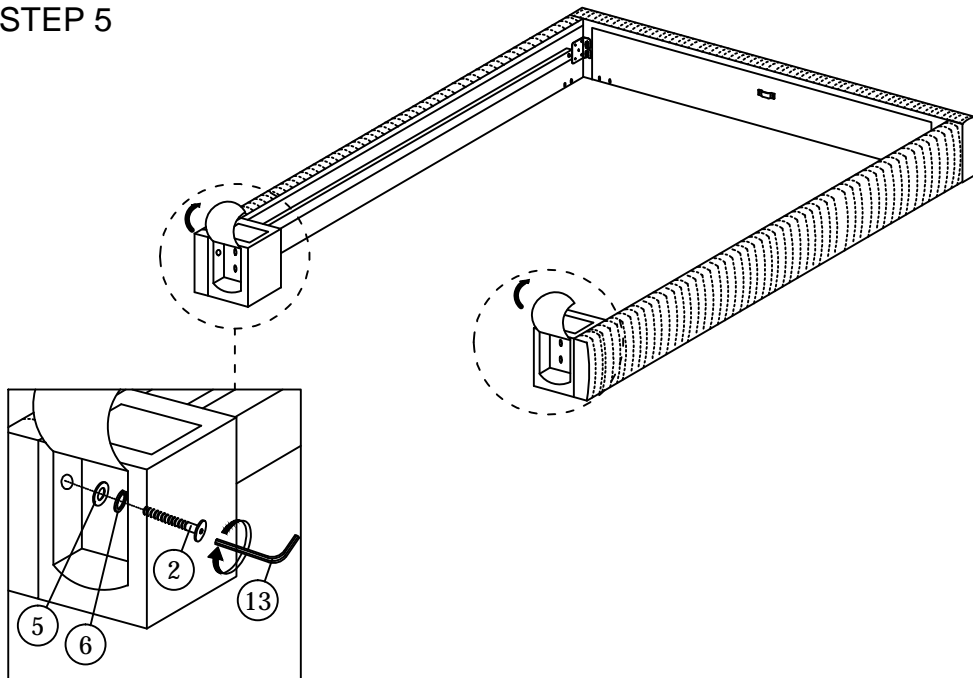

STEP 6

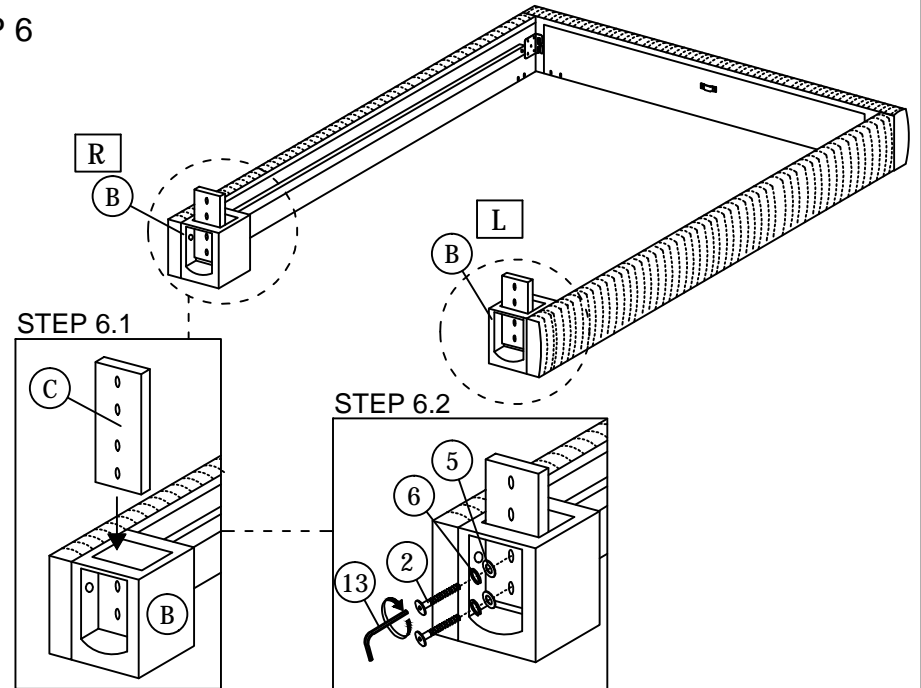

# ASSEMBLY INSTRUCTIONS

STEP 7

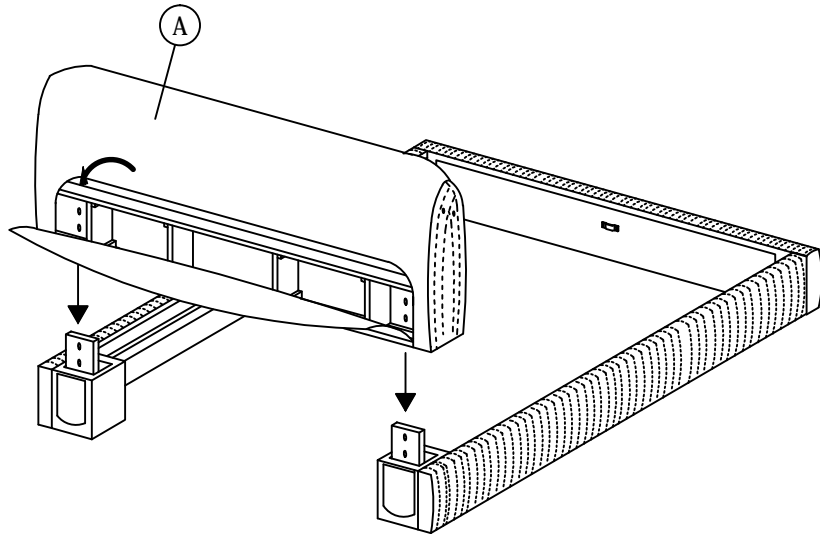

STEP 8

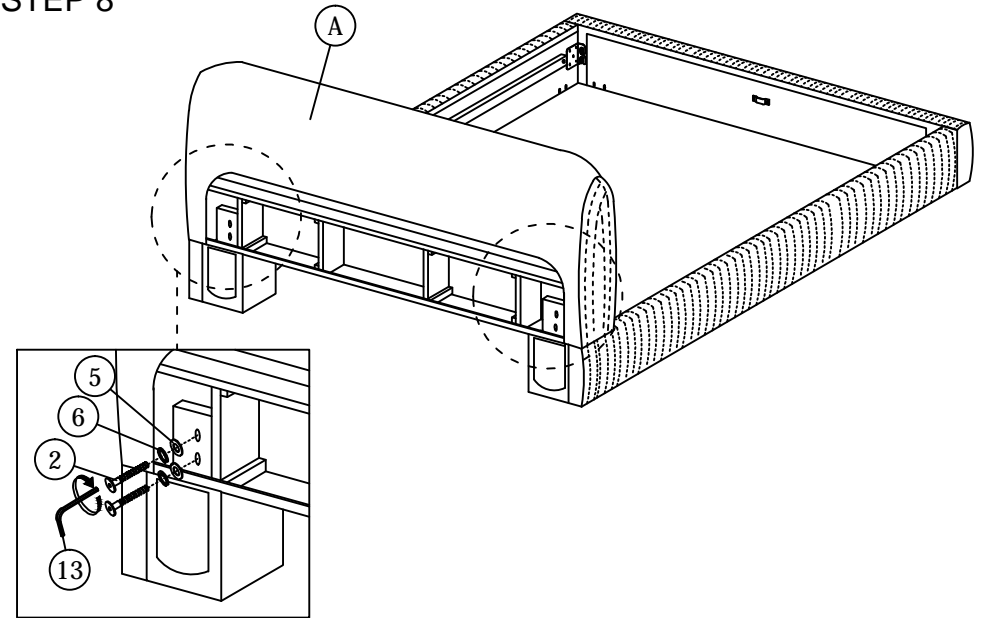

STEP 9

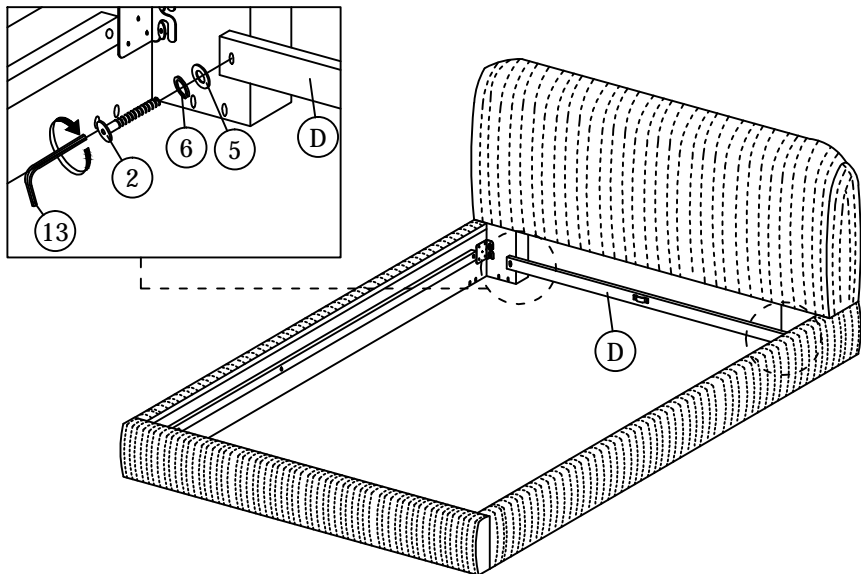

STEP 10

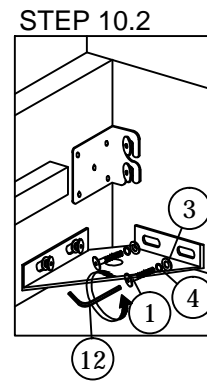

STEP 10.1

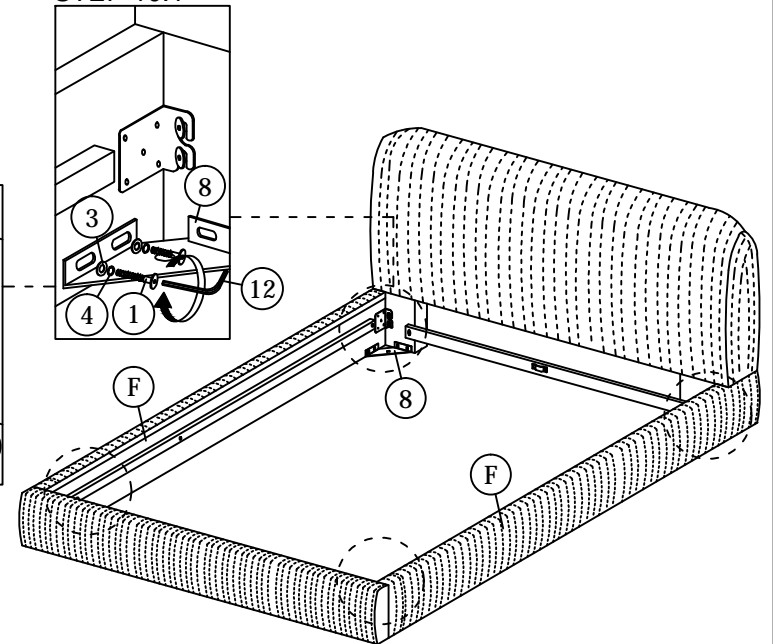

# ASSEMBLY INSTRUCTIONS

STEP 11

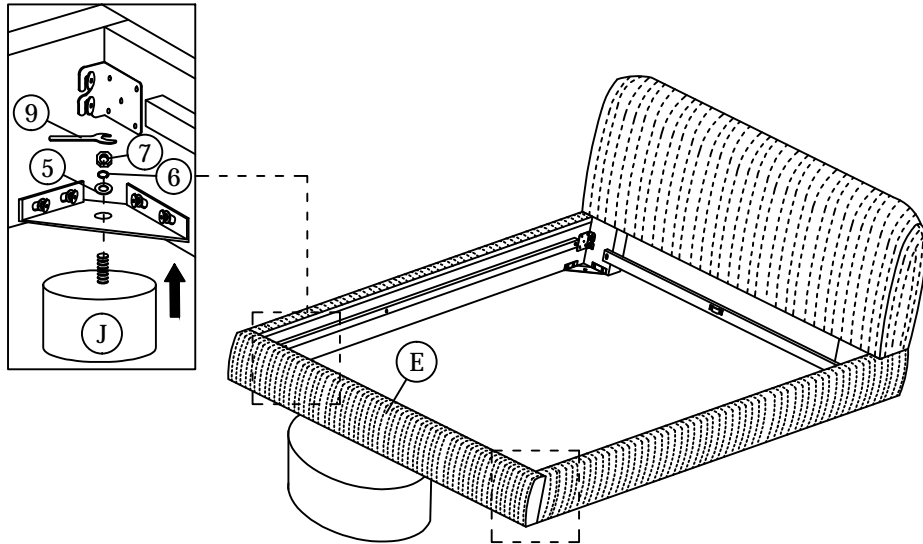

STEP 12

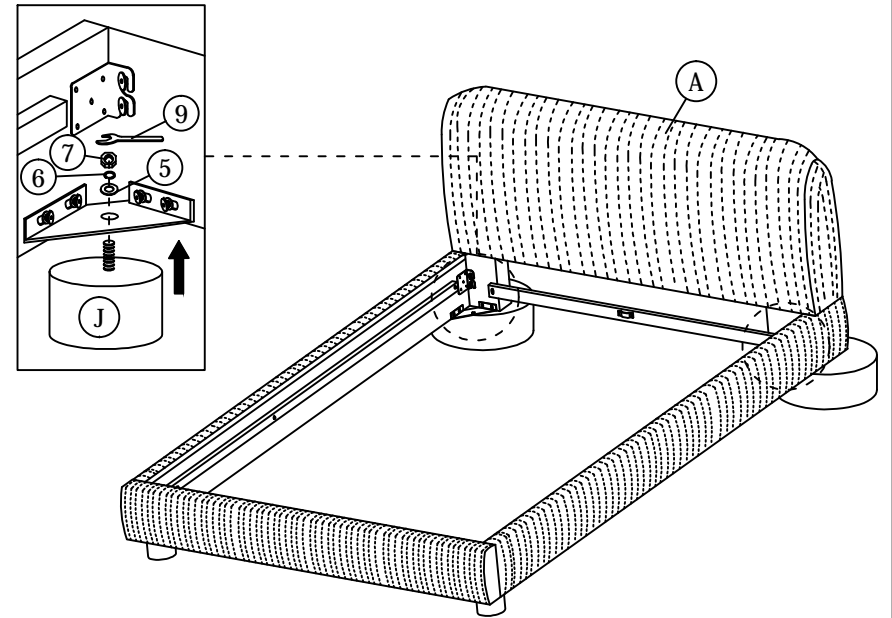

STEP 13

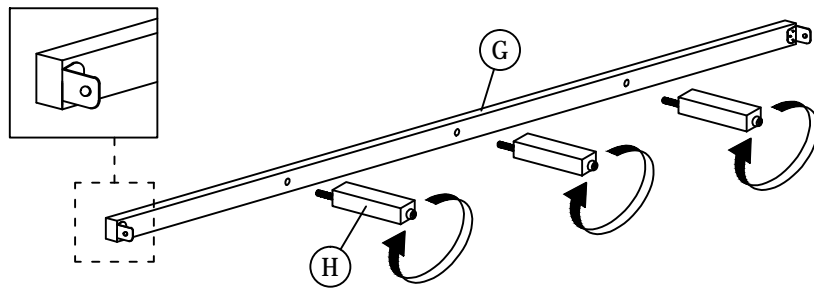

STEP 14

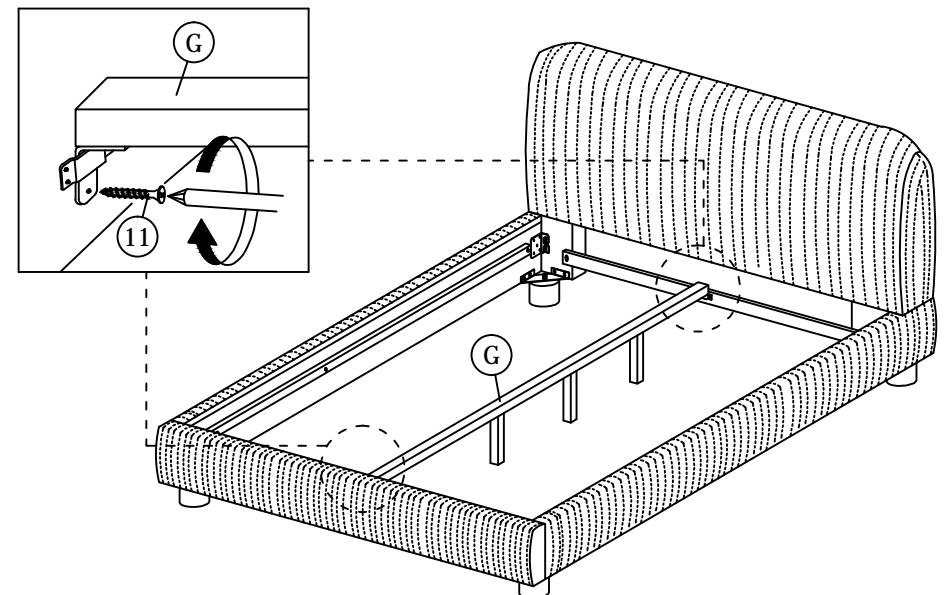

## STEP 15

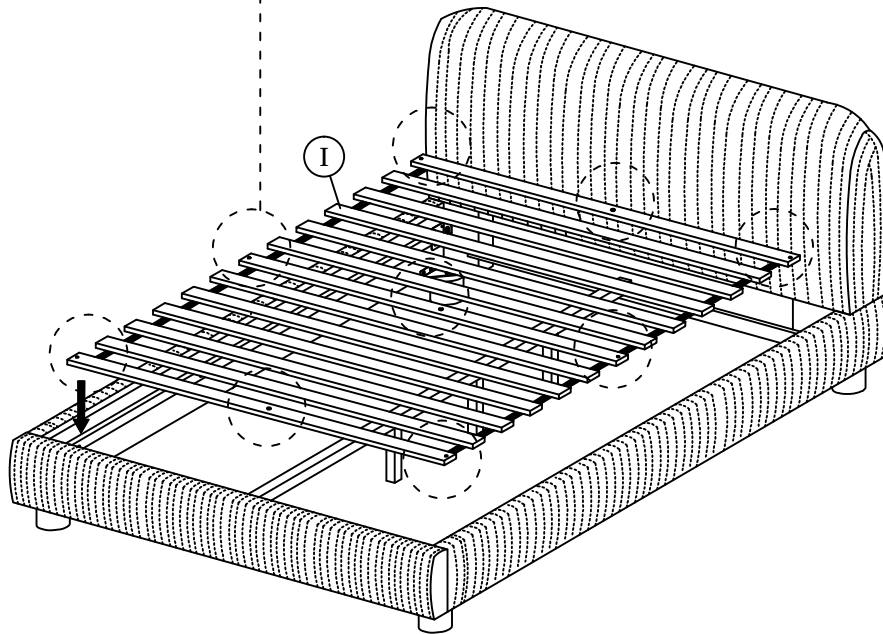
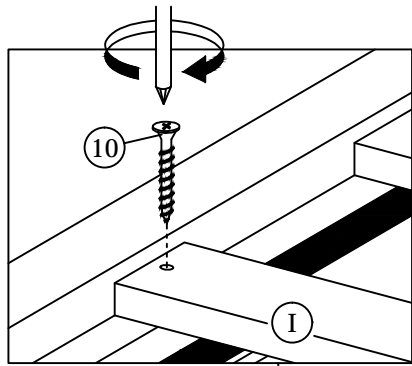

## STEP 16

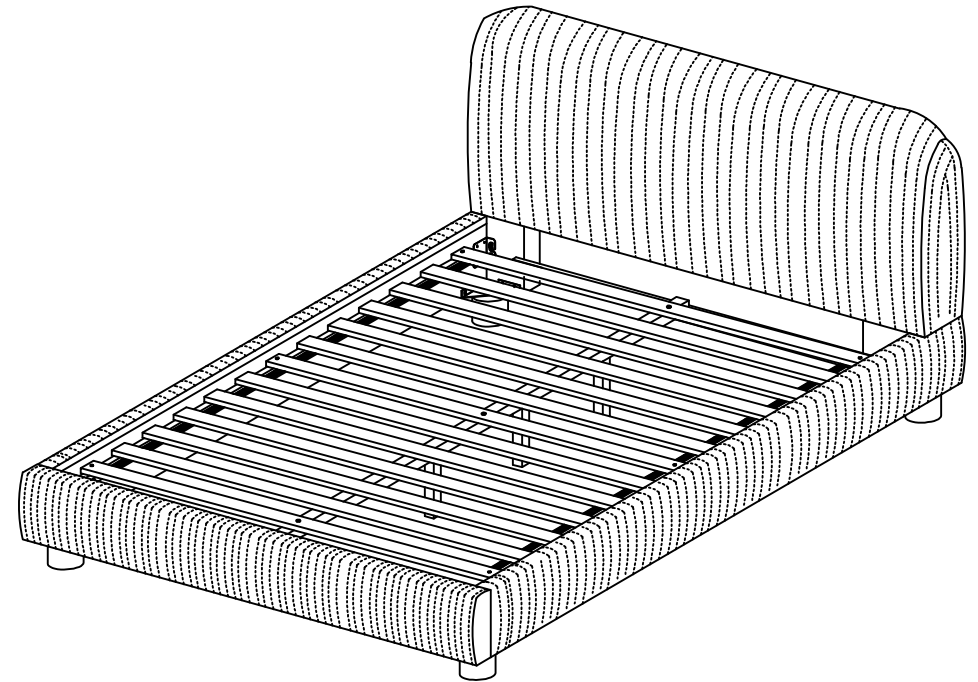

**\* When moving the bed position, the center support legs must be adjust to be straight to avoid any broken problem.**