

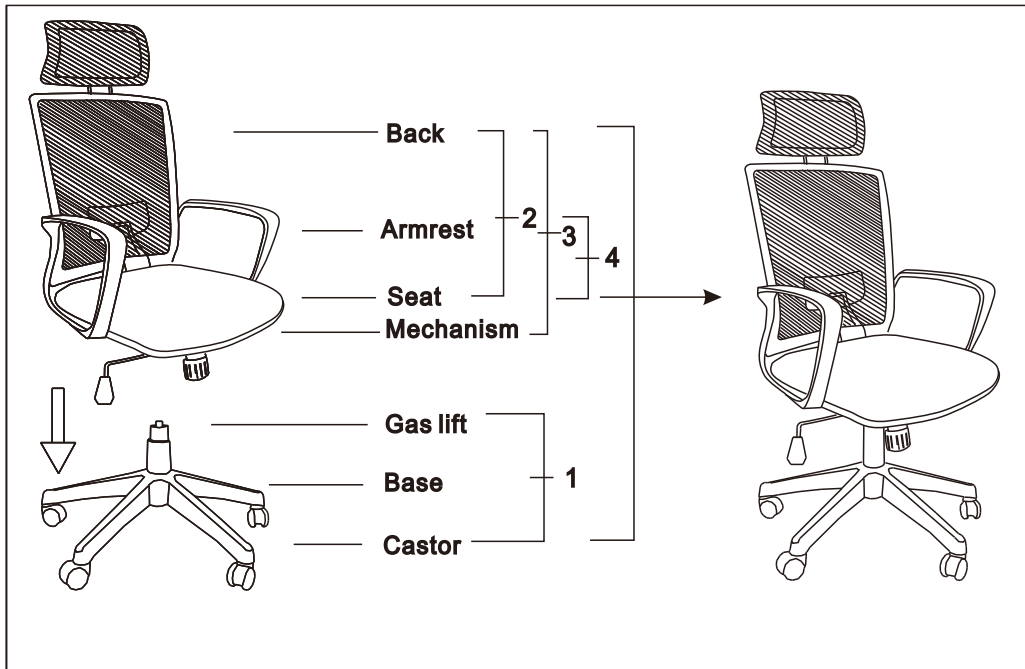

ASSEMBLY INSTRUCTIONS

" functional seating for today's workplace "

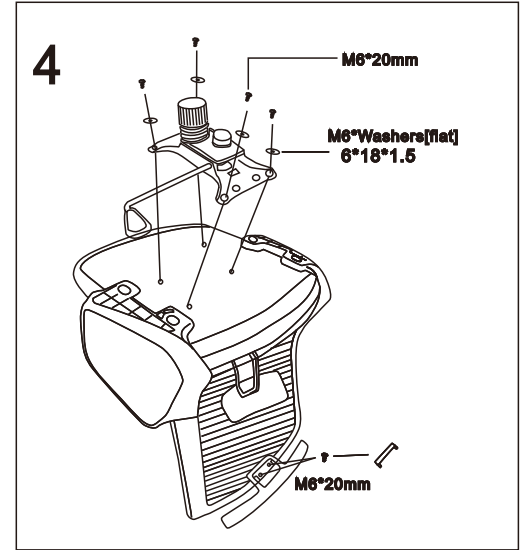
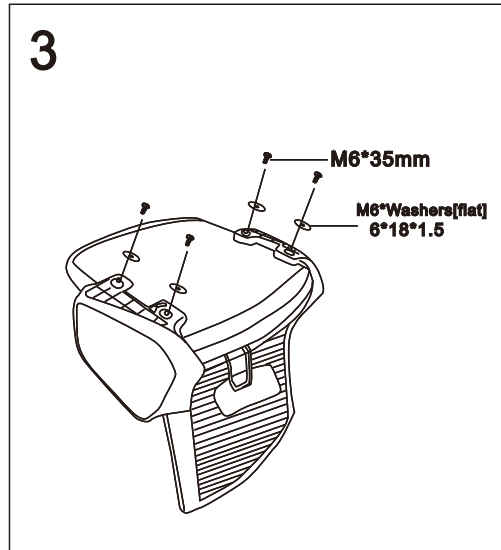
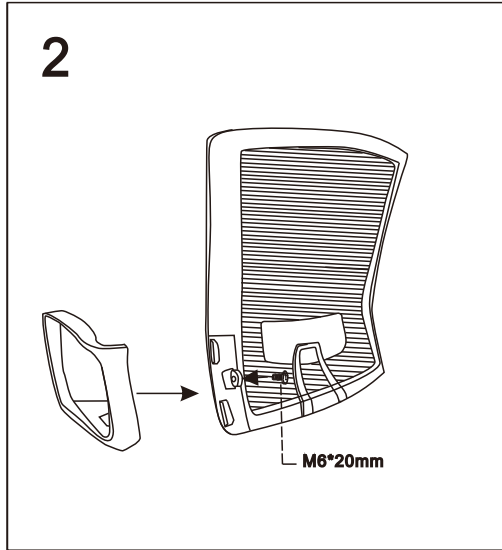
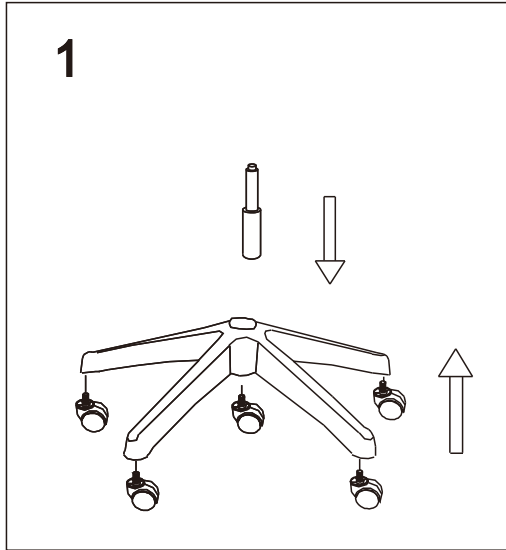

	
	Flat
M6*35mm	4
M6*20mm	8
	6*18*1.5
	8

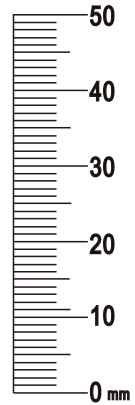

Use the ruler to help identify parts

Part s

Check i st

PREVENTIVE MAINTENANCE AND WARNING

- ONLY FOR SEATING ONE PERSON AT A TIME.
- DO NOT USE CHAIR AS STEP STOOL OR LADDER.
- DO NOT USE CHAIR UNLESS ALL BOLTS,SCREWS ARE TIGHT.
- AT LEAST EVERY SIX MONTHS CHECK ALL BOLTS AND SCREWS TO BESURE THEY ARE TIGHT.
- IF ANY PARTS ARE MISSING,BROKEN,DAMAGED OR WORN, STOP USING THE PRODUCT UNTIL REPAIRS ARE MADE WITH FACTORY AUTHORIZED PARTS.
- FAILURE TO FOLLOW THESE WARNINGS CAN RESULT IN SERIOUS INJURY.