

Loft Bed

ASSEMBLY, CARE & USE INSTRUCTIONS

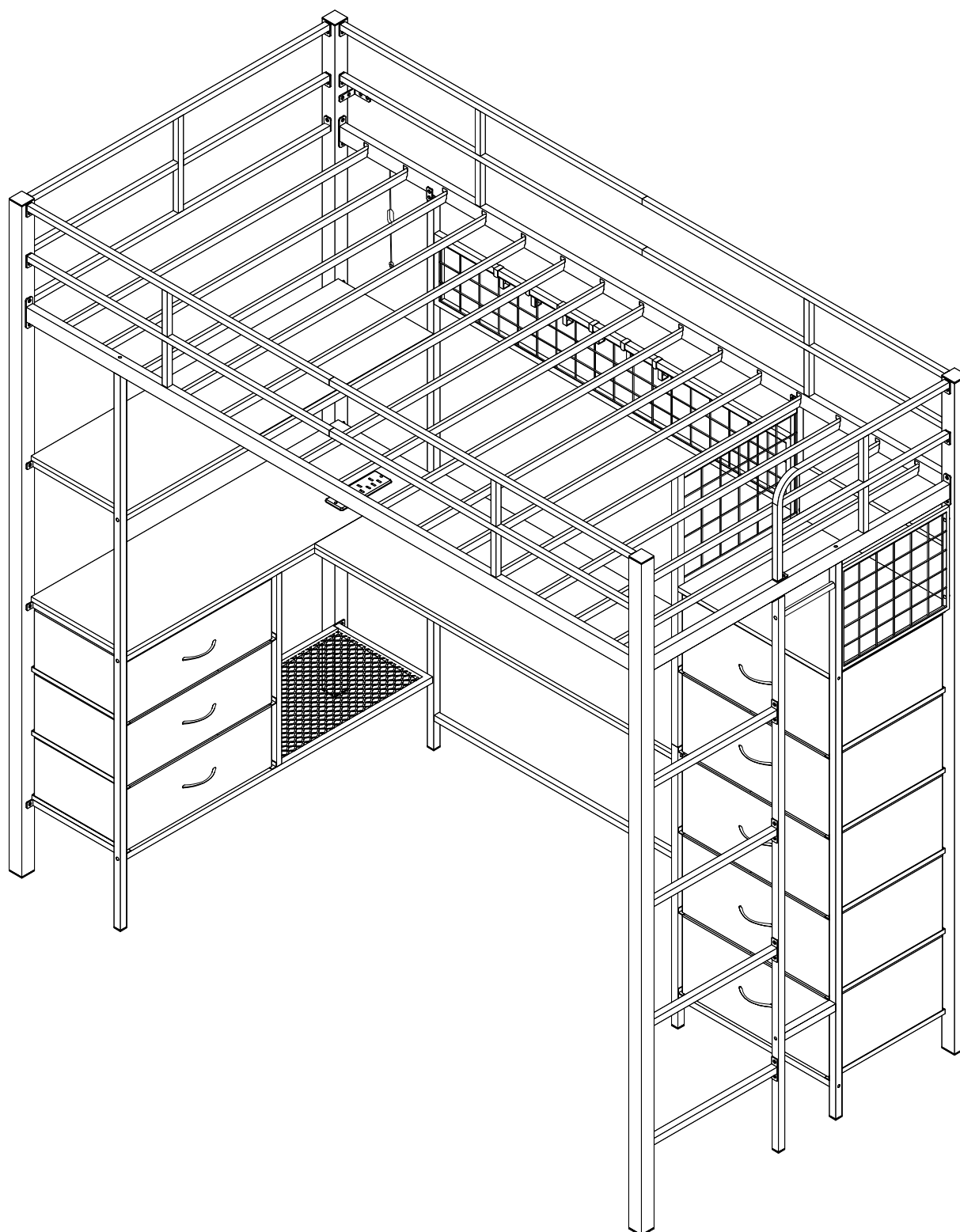

XNY25040701-black

THANK YOU

We appreciate the trust to purchase our Loft Bed. We strive to continually create quality products designed to enhance your home. Visit us online to see our full line of products available for your home improvement needs. Thank you for choosing us!

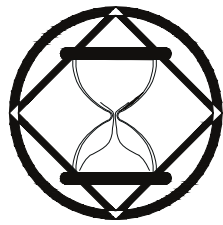

Estimated time for assembly:

90 mins

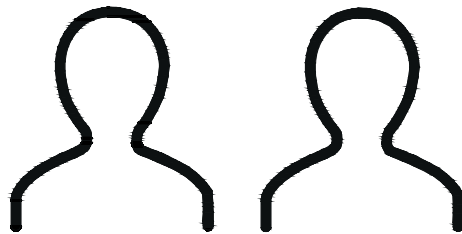





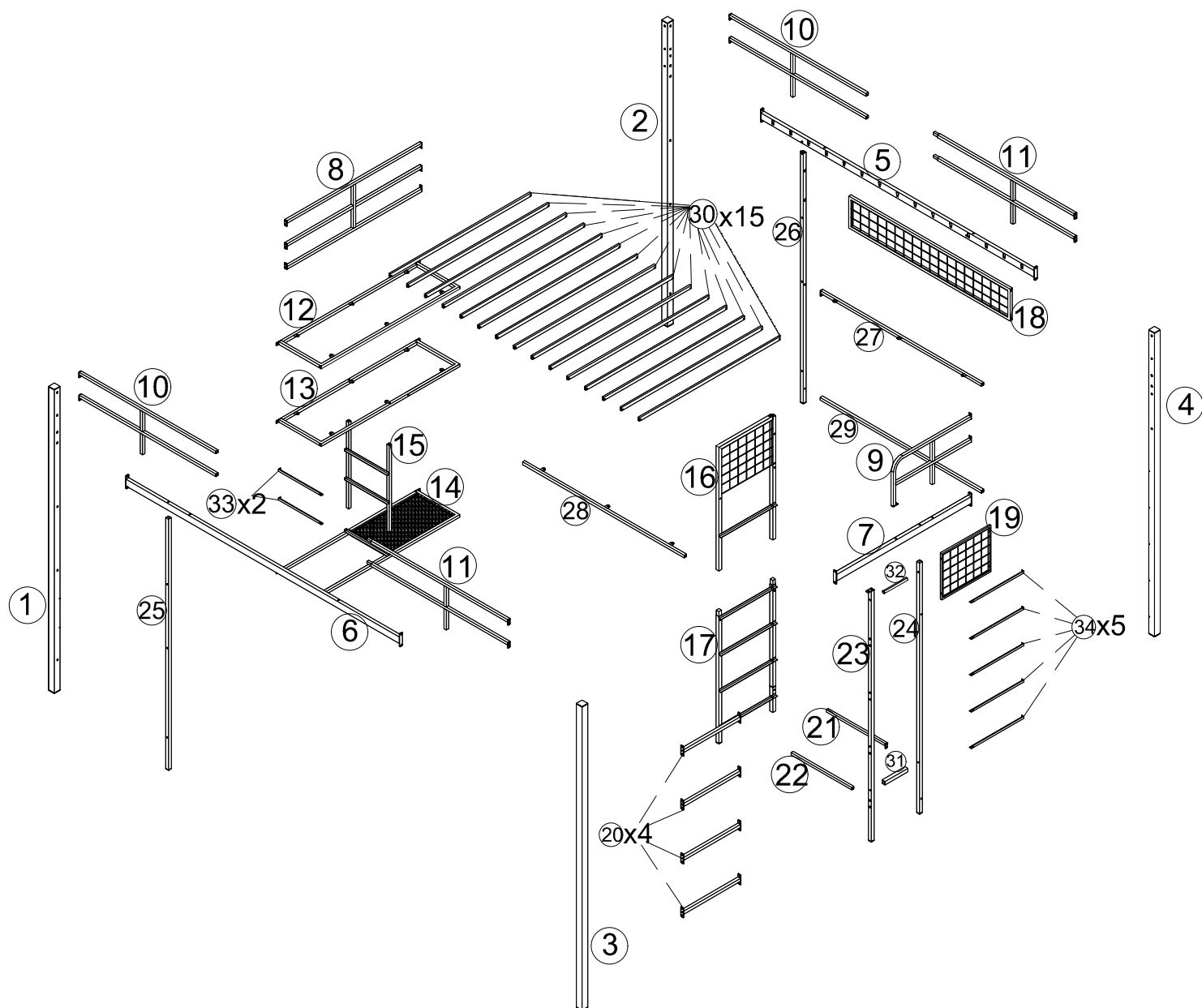
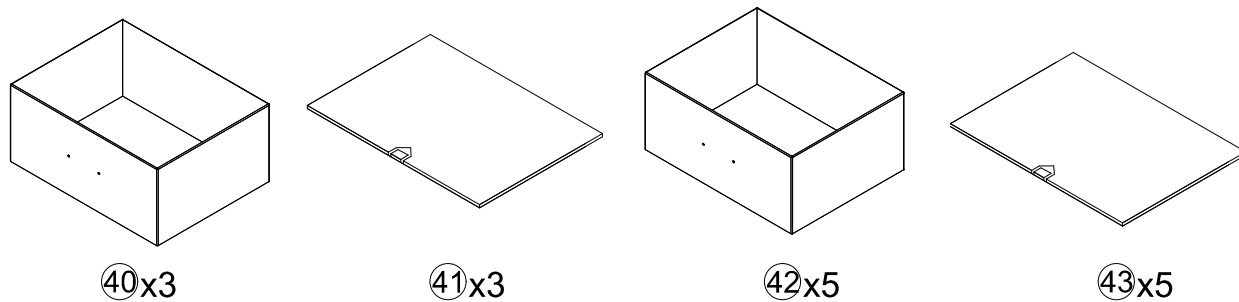
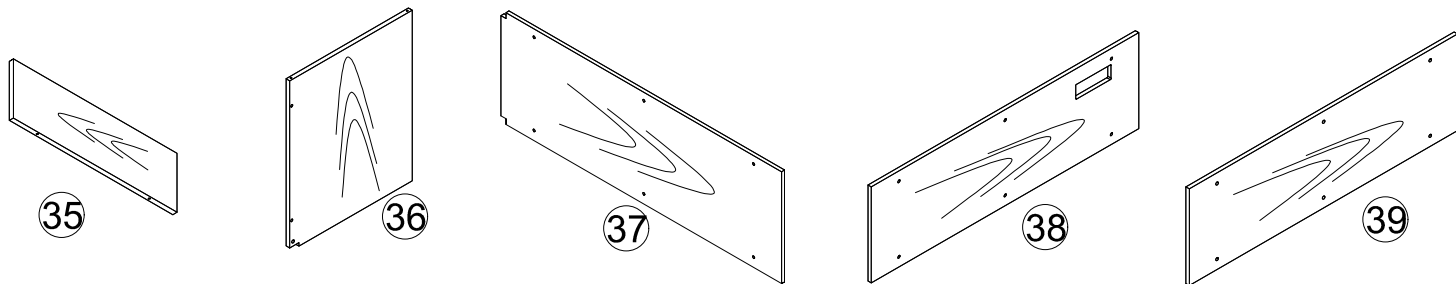









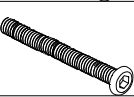





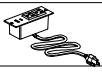

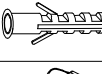
2 Personer

PACKAGE CONTENTS



Hardware List

A			s hook	6 PCS
B			Anti collapse ironsheet	2 PCS
C			Double hole L ironsheet	2 PCS
D			Square iron sheet	1 PC
E		8x15mm	Hexagonal socket screw	12+1 PCS
F		6x12mm	Hexagonal socket screw	55+5 PCS
G		6x28mm	Hexagonal socket screw	22+2 PCS
H		6x50mm	Hexagonal socket screw	4+1 PCS
J		4x8mm	Flat head cross screw	14+1 PCS
K		5x48mm	Direct screw	5+1 PCS
L		ø3.5x12mm	Screw	2+1 PCS
M		5x40mm	Screw	2 PCS
N		4x8mm	Screw	16+1 PCS
P			socket	1 PC
Q			shake hands	8 PCS
R			Expansion rubber plug	2 PCS
S		L1800mm	Light belt	1 PC
T			Line card deduction	5 PCS
U			Buckle	30+2 PCS
V			Allen wrench S3	1 PC
W			Allen wrench S4	1 PC
X		6x50mm	Countersunk screw	4+1 PCS
Y		6x30mm	Countersunk screw	6+1 PCS
Z		6x10mm	Hexagonal socket screw	19+1 PCS

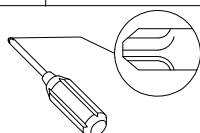

Philips head screwdriver required for assembly
(not included)

Step 1

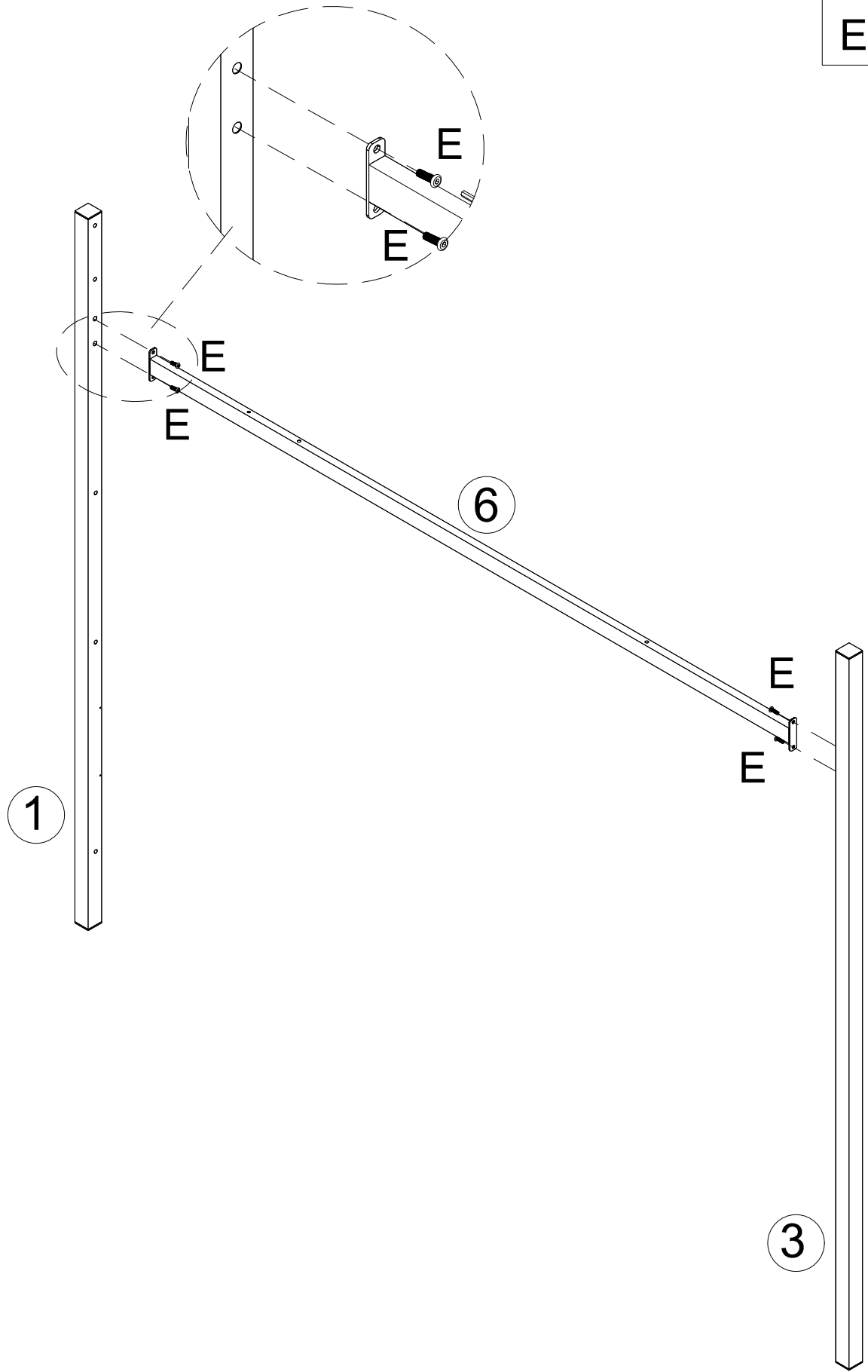
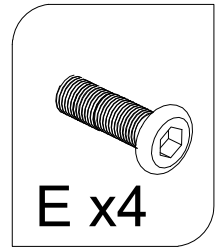

Step 2

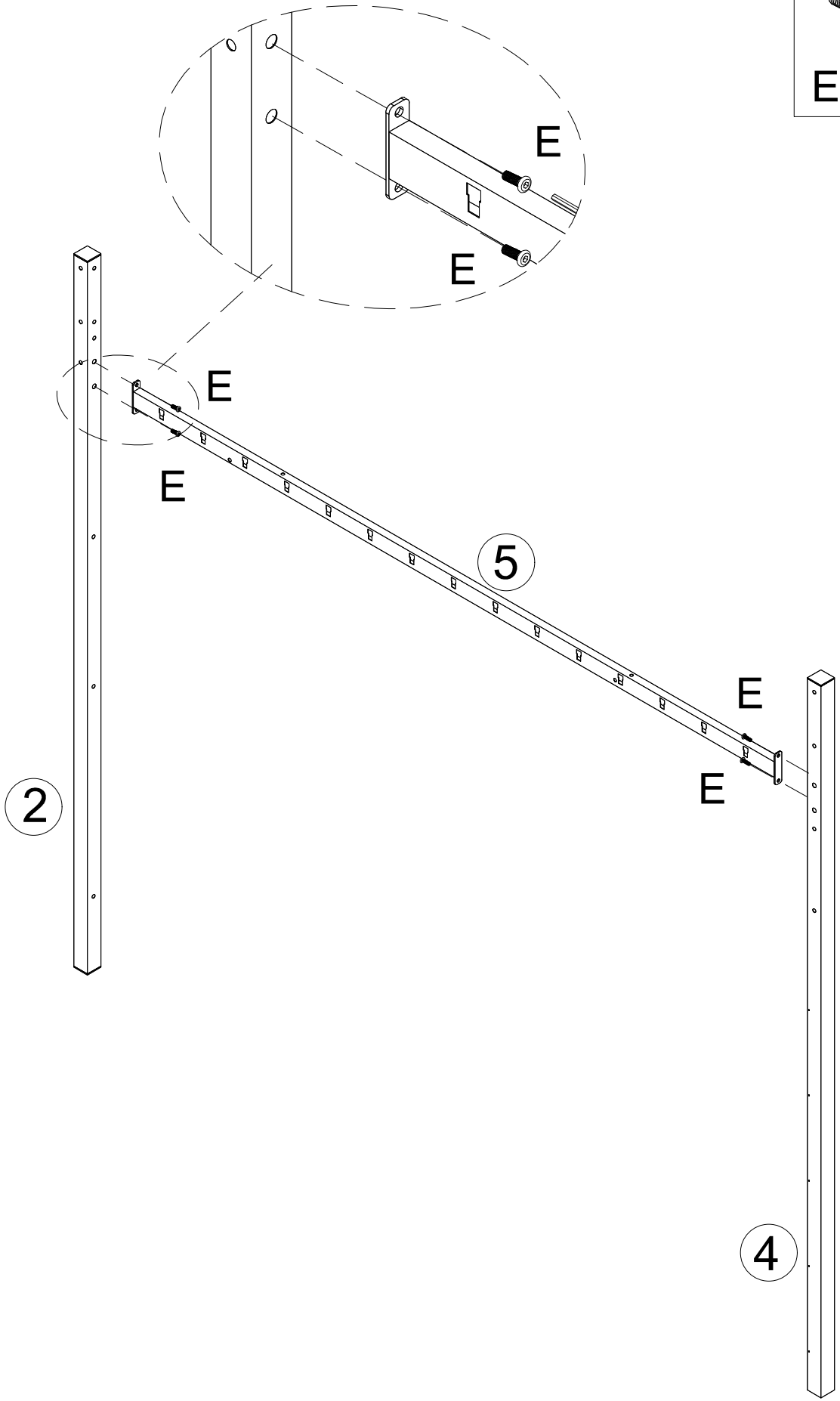
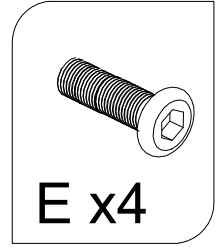

Step 3

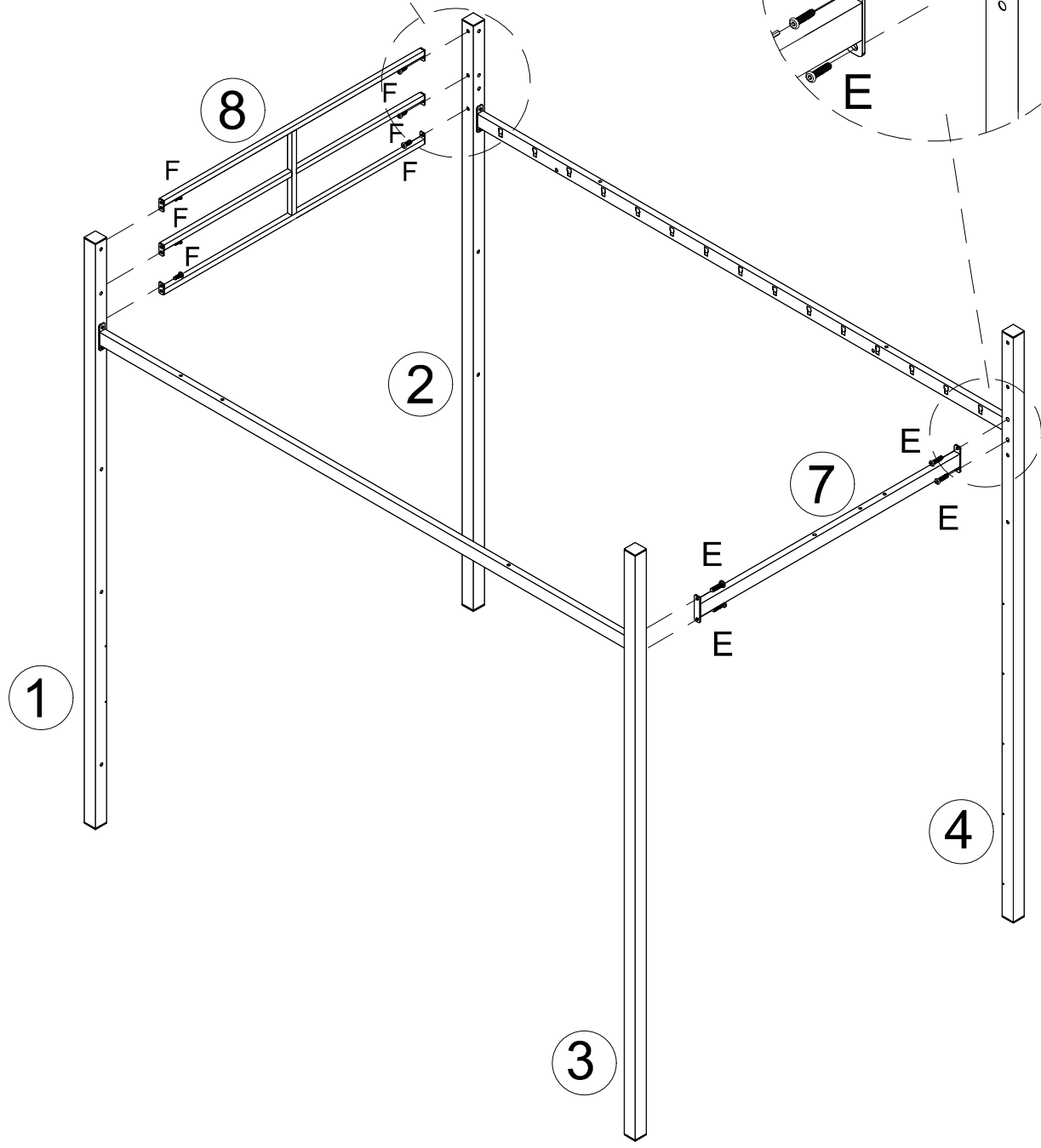
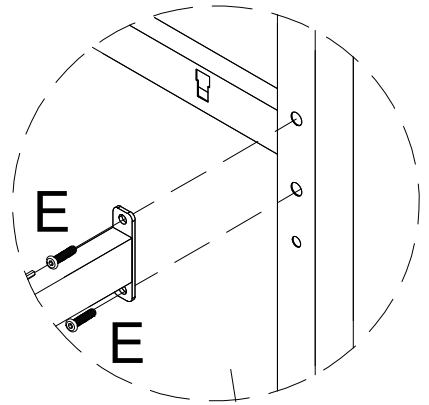
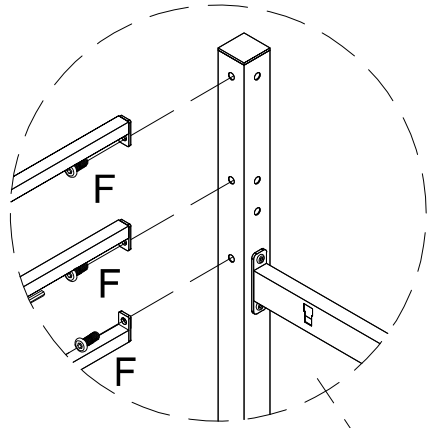
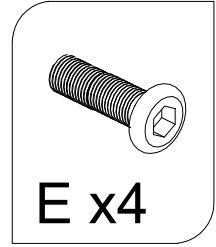
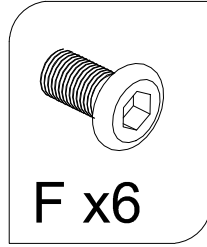

Step5

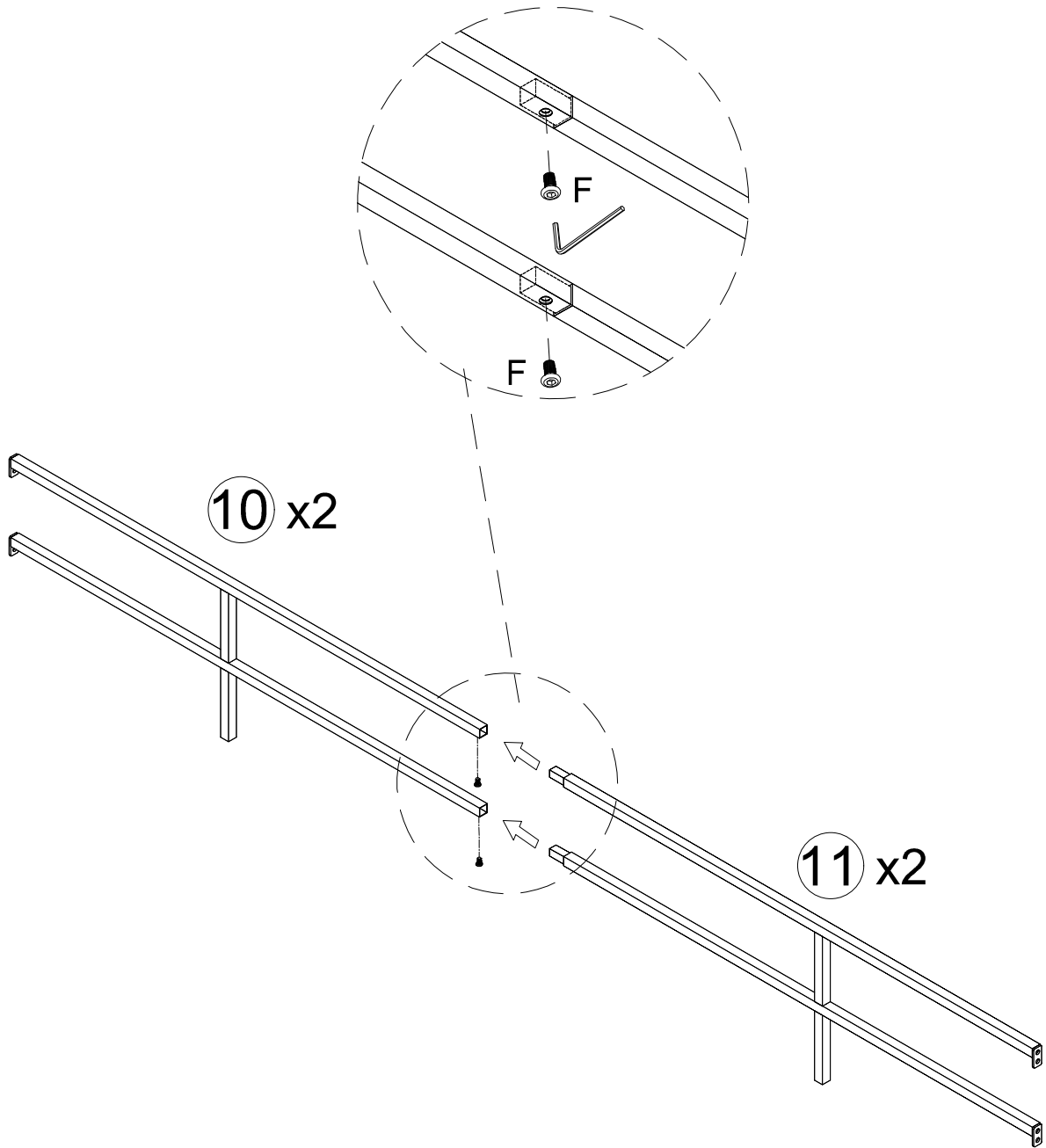
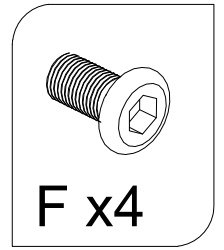

Step 6

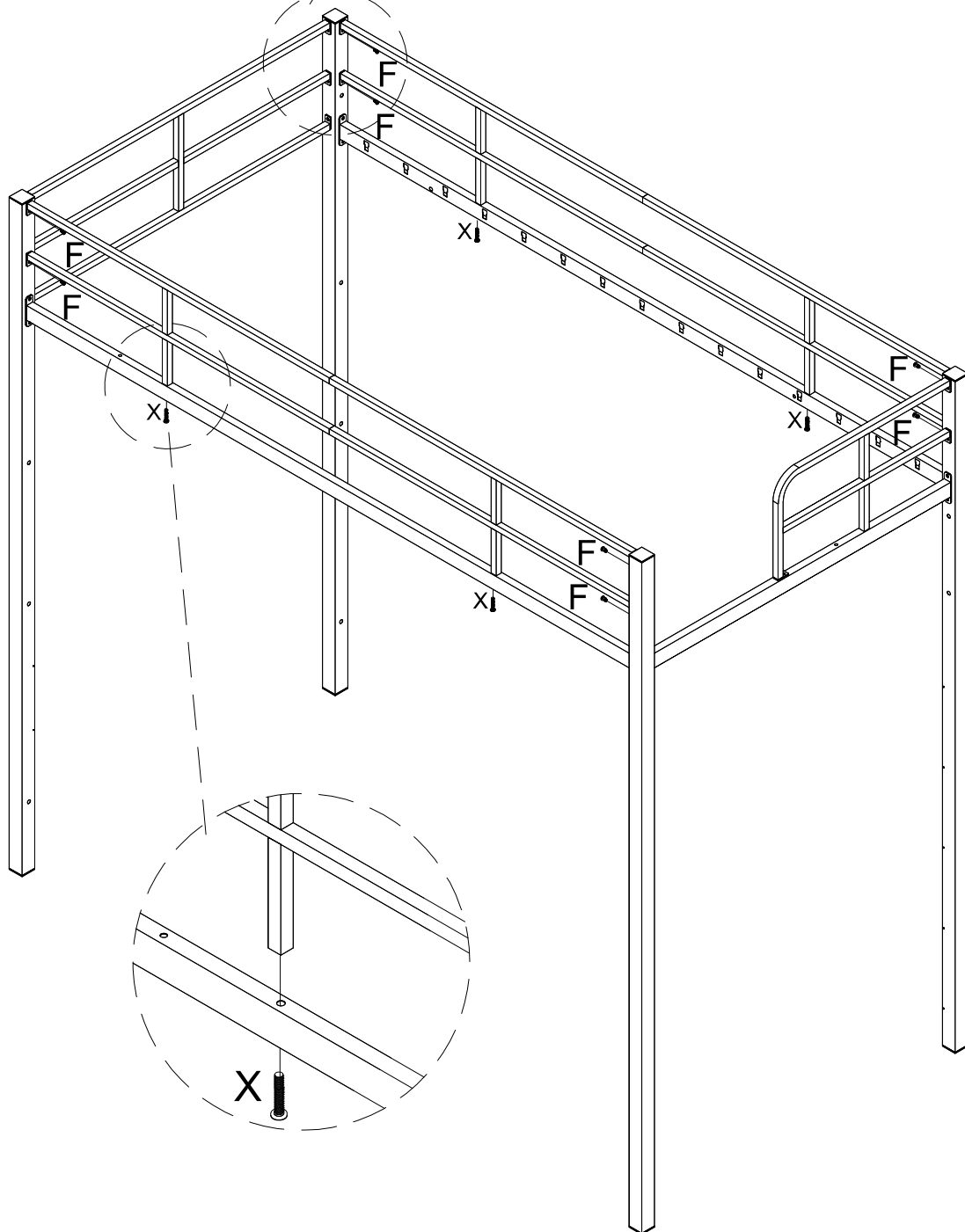
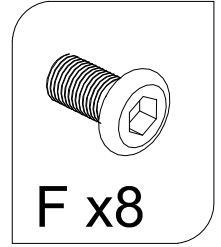
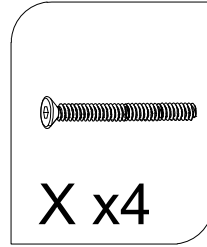
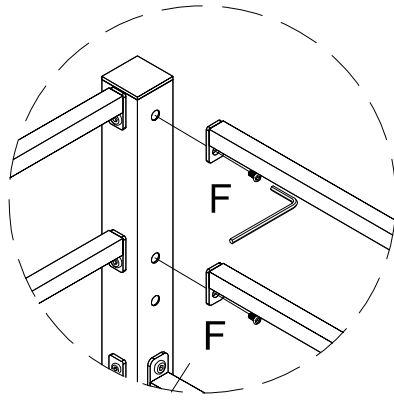

Step 7

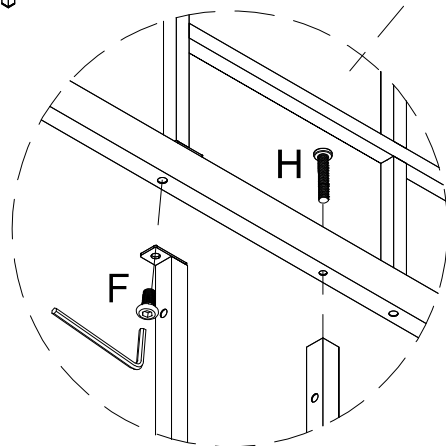
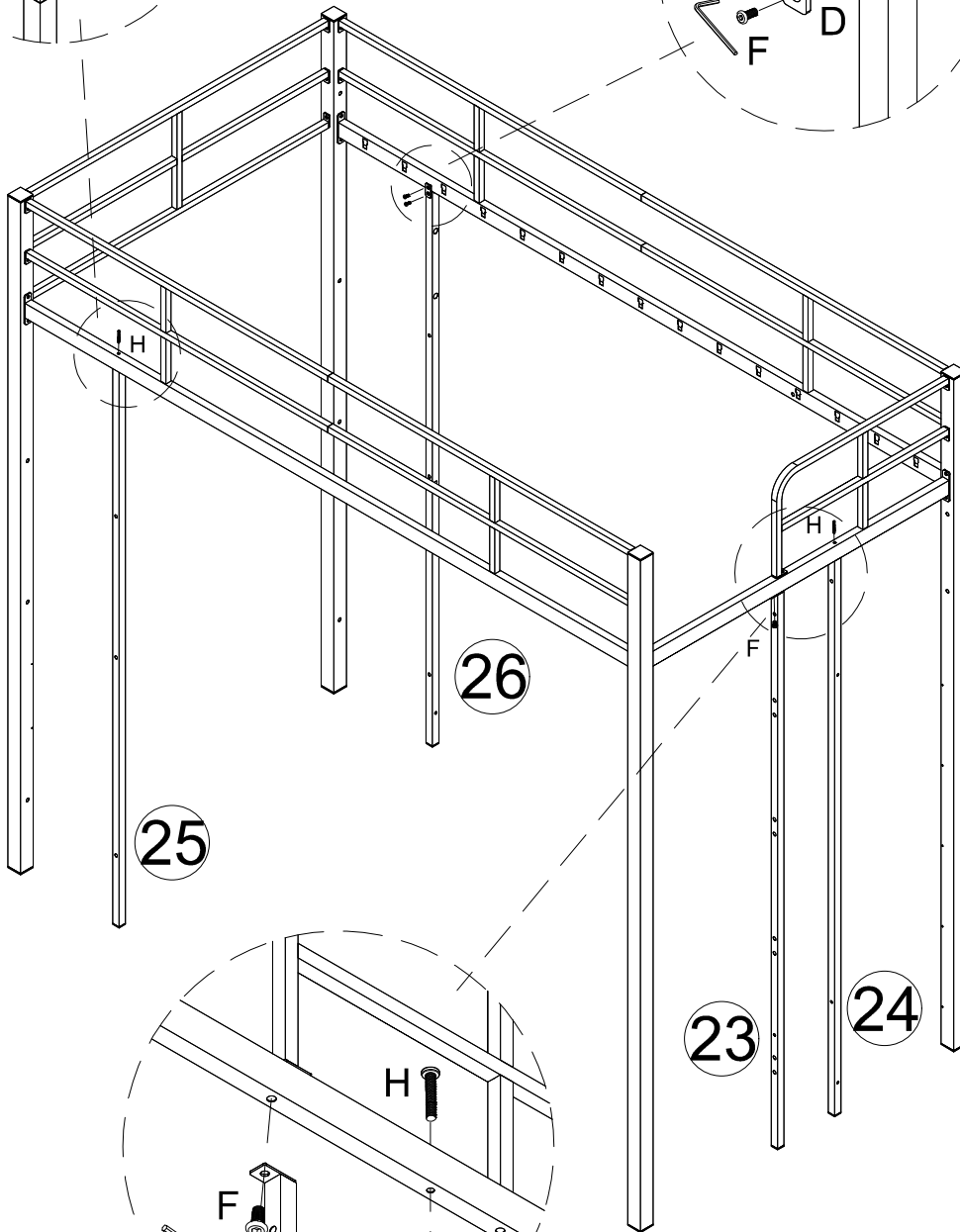
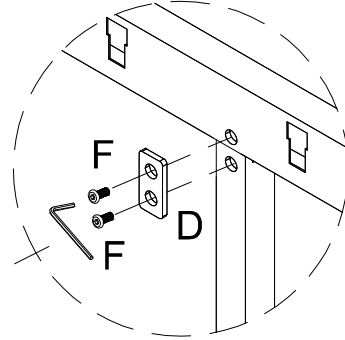
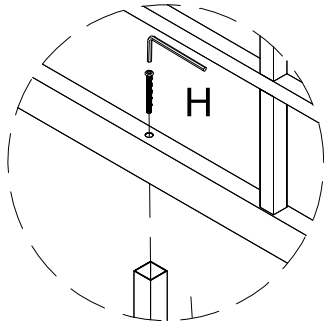
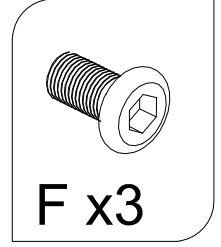
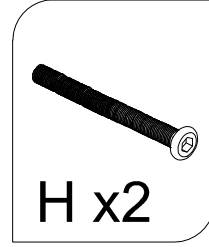
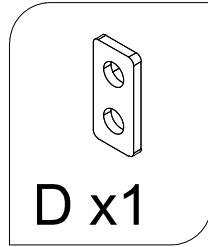

Step 8

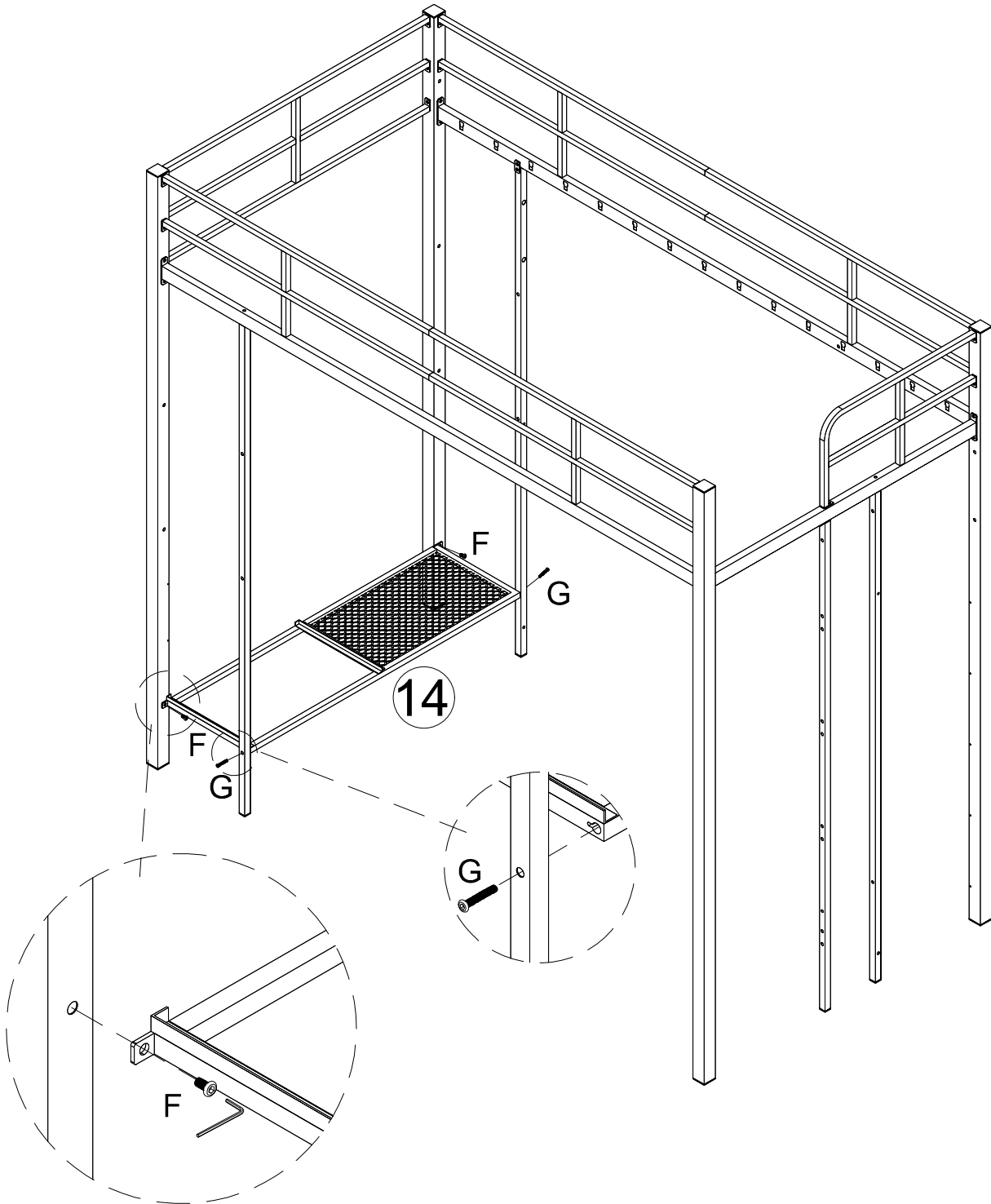
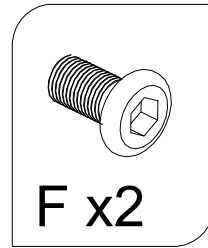
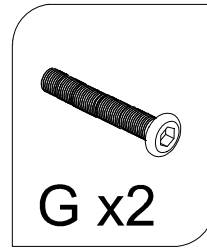

Step 9

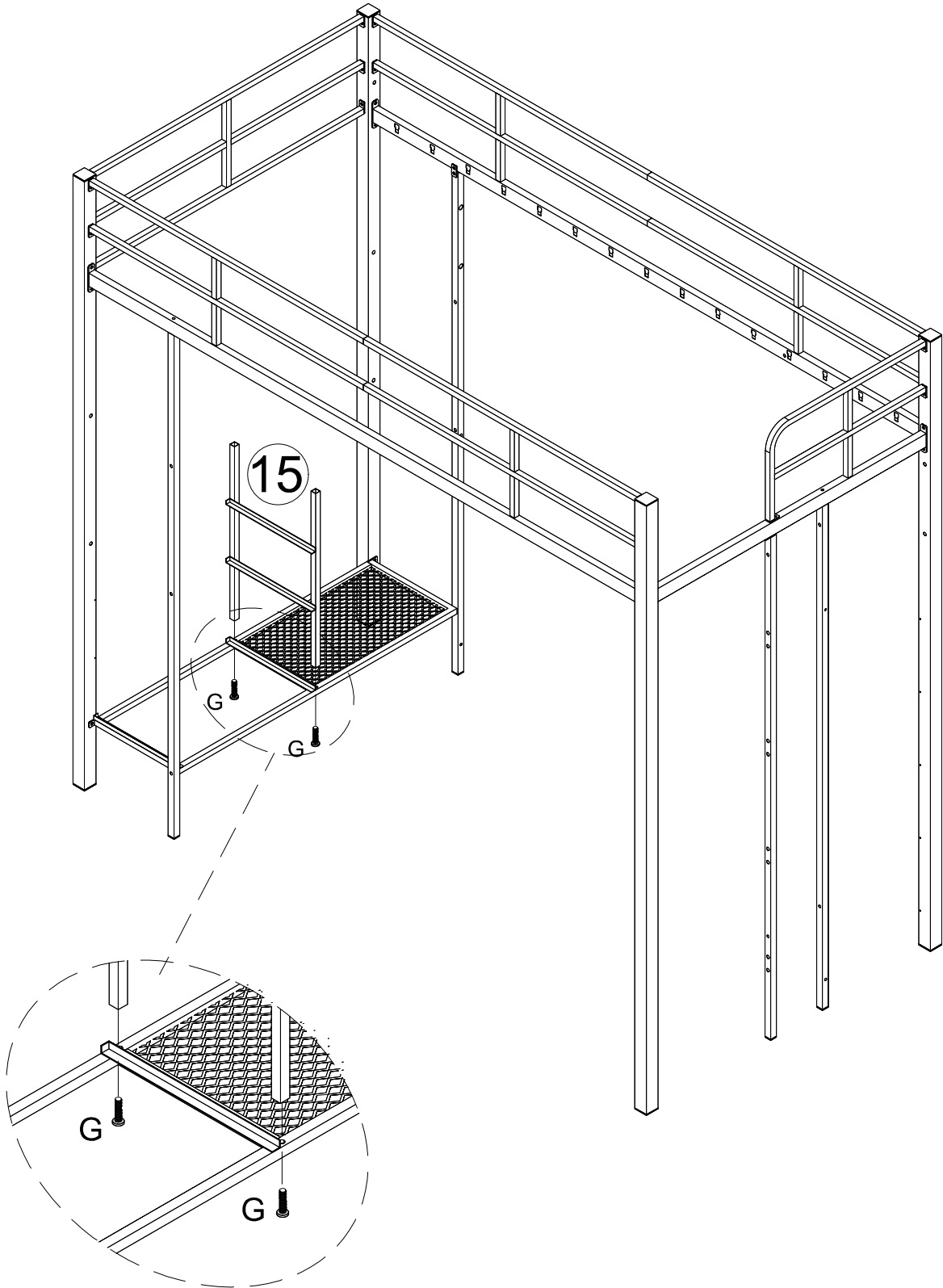
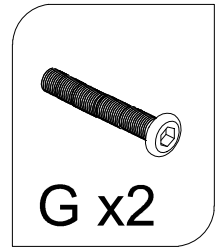

Step 10

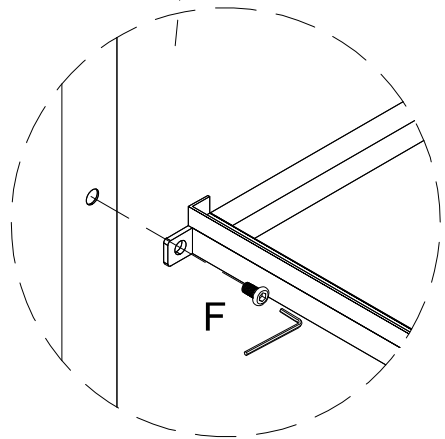
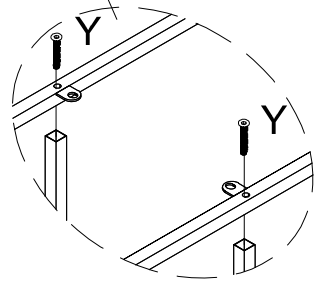
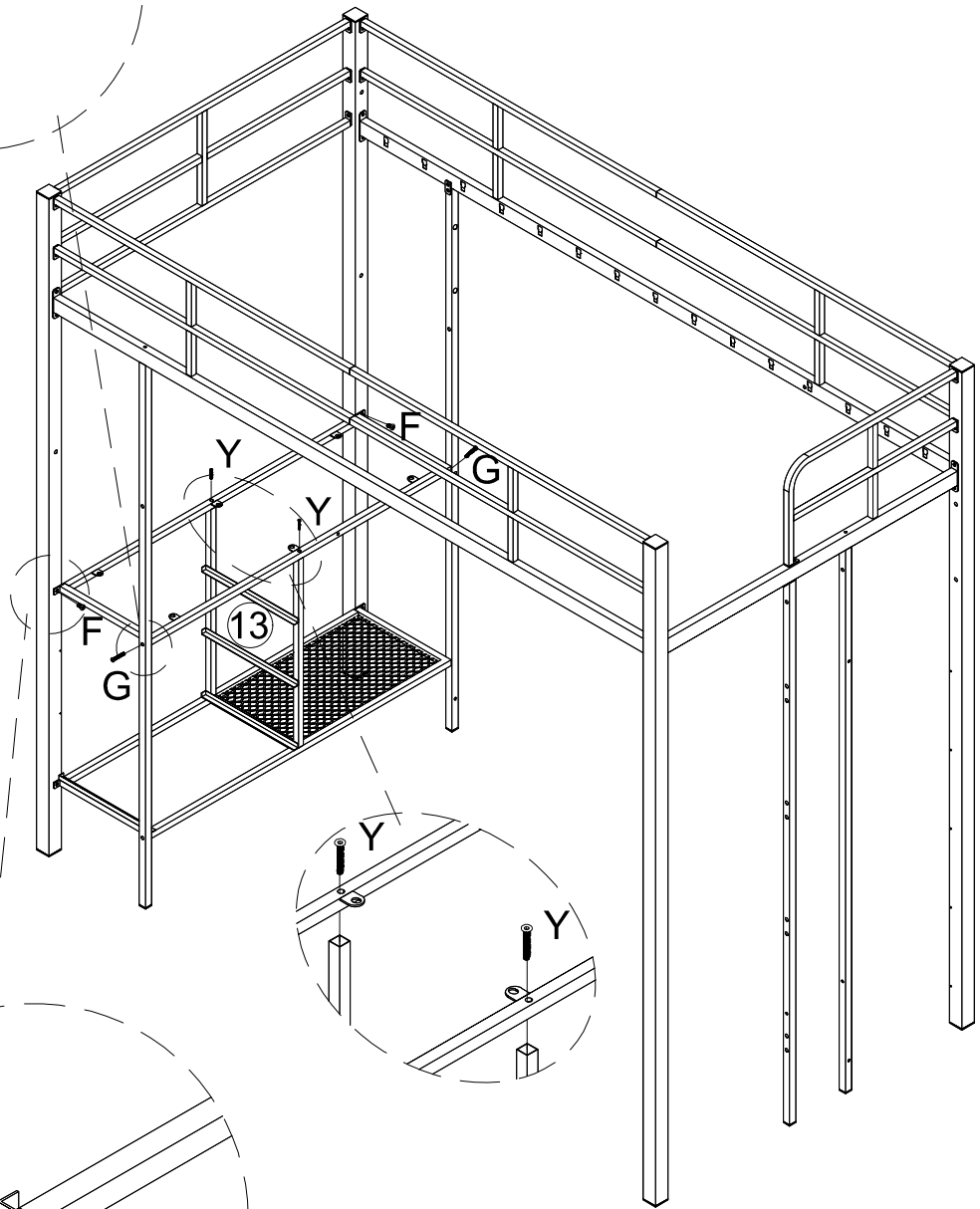
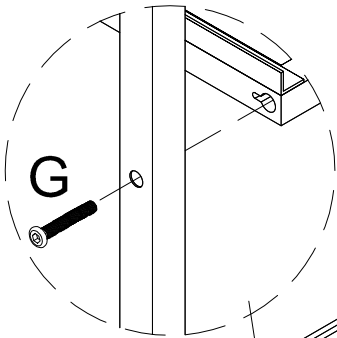
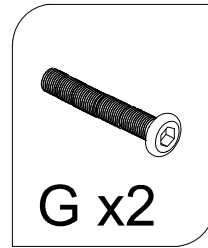
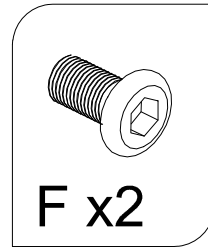
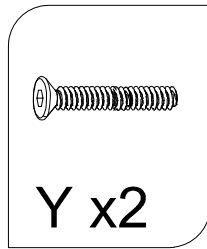

Step 11

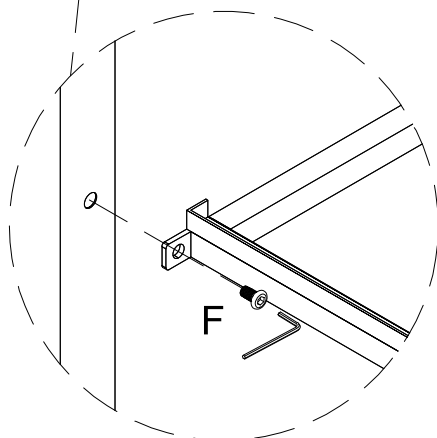
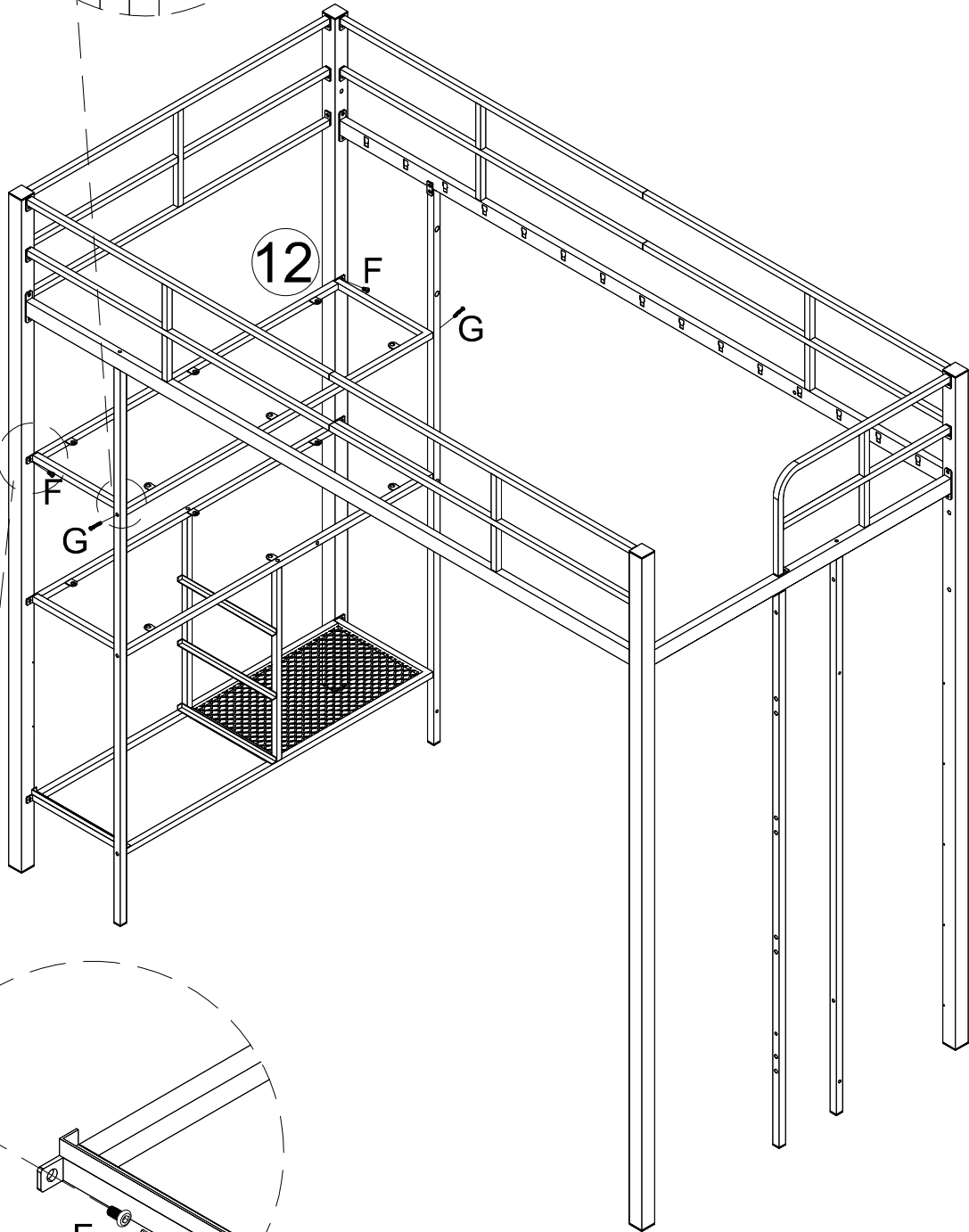
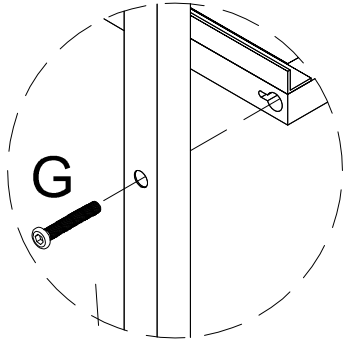
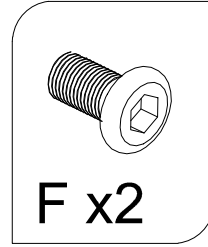
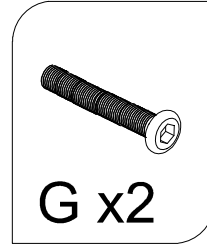

Step 12

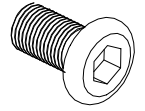

F x16

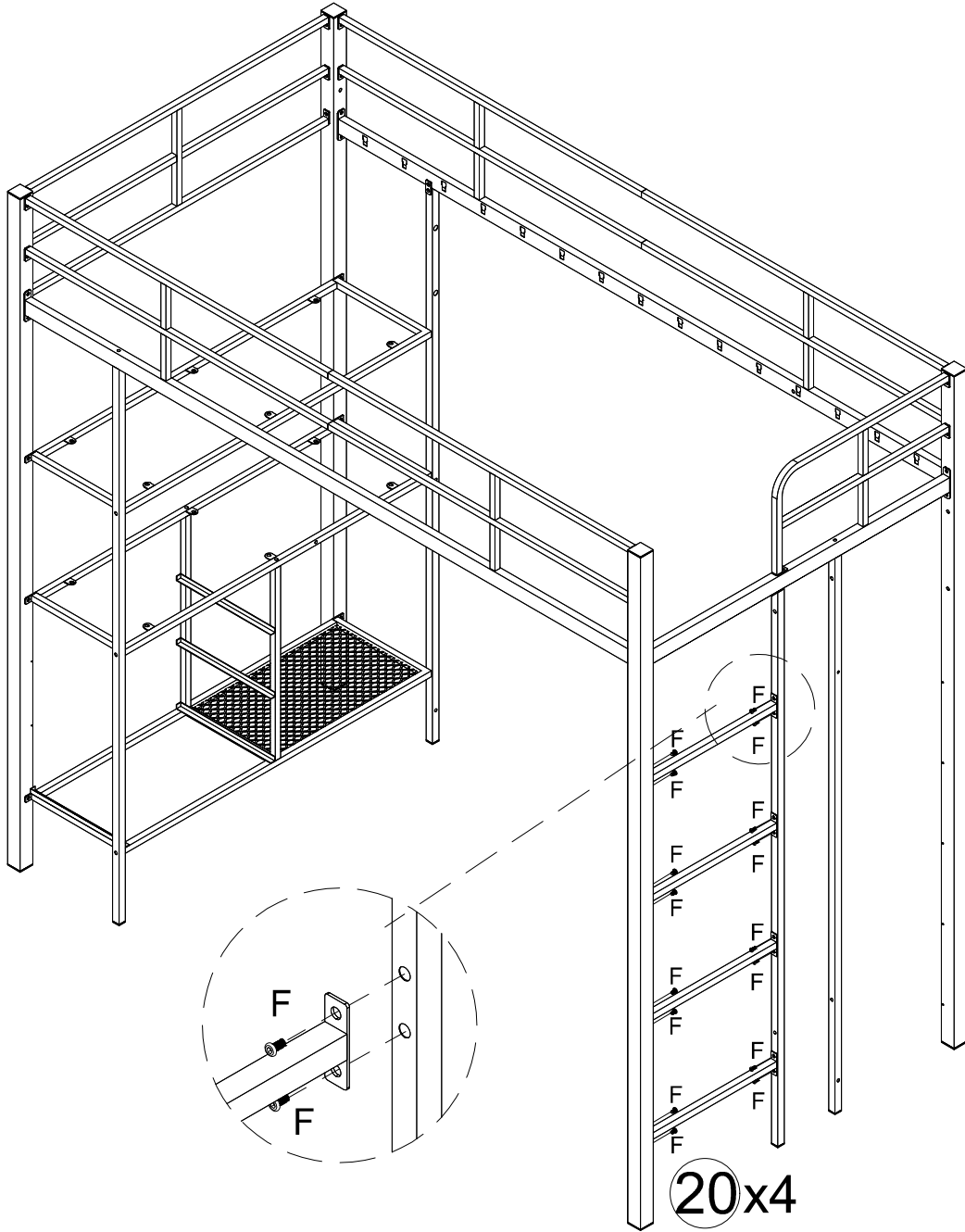

Step 13

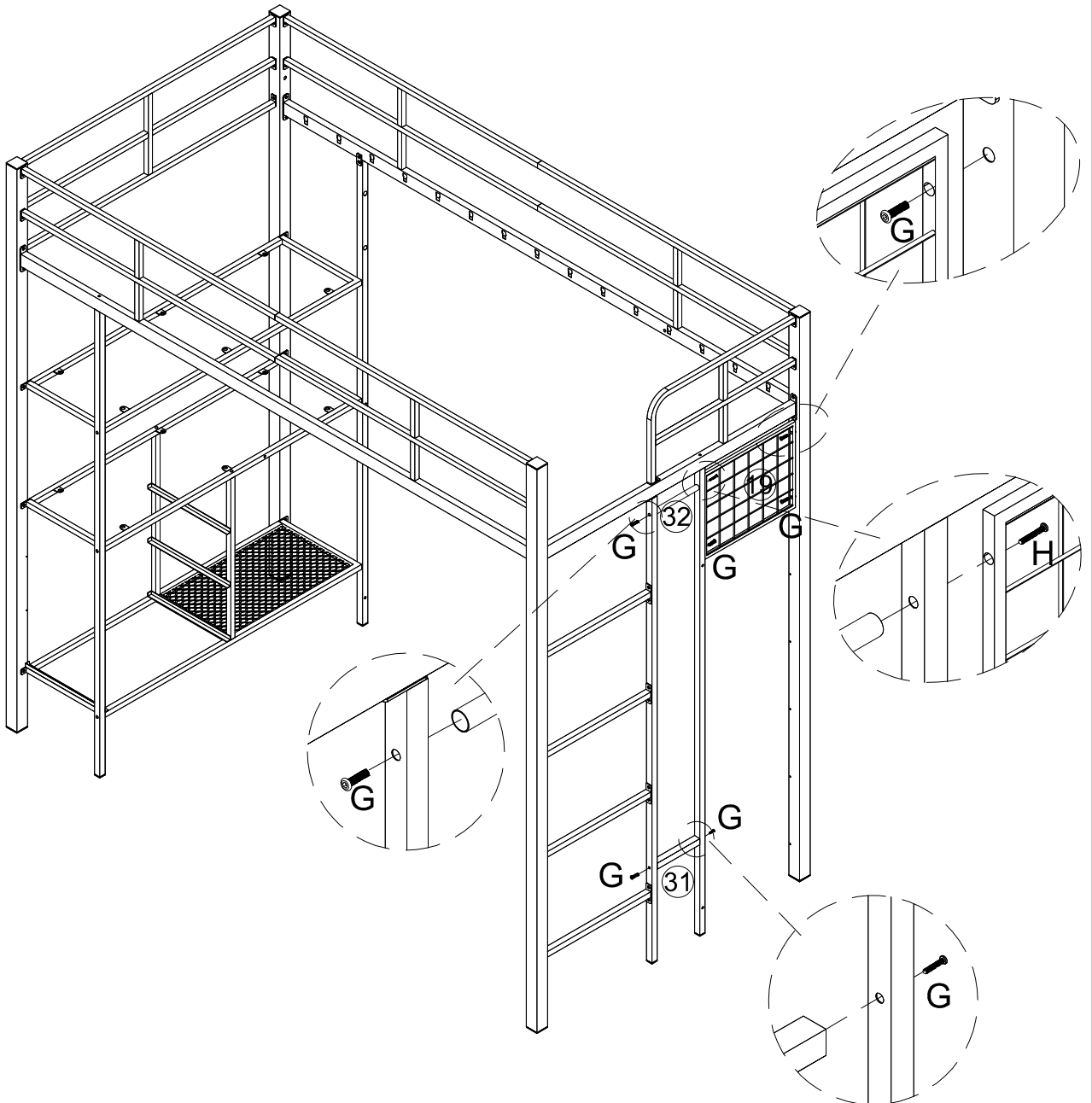
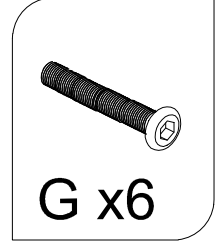
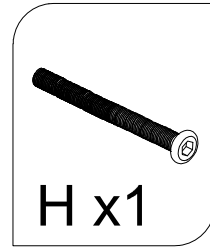

Step 14

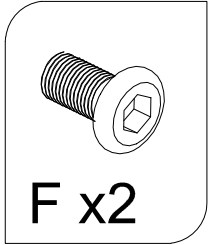
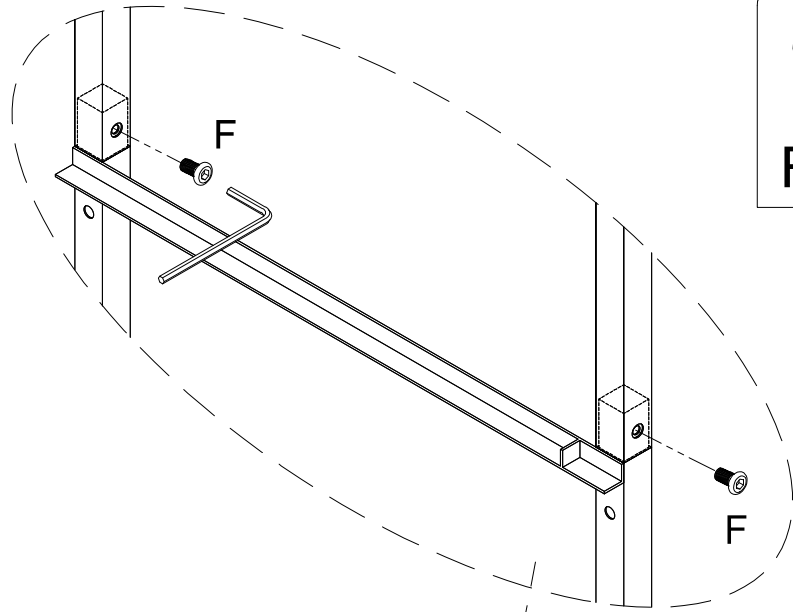

16

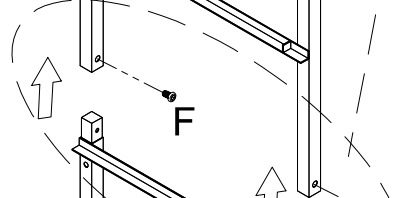

17

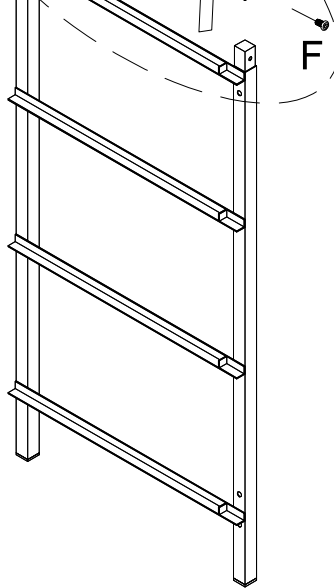

Step 15

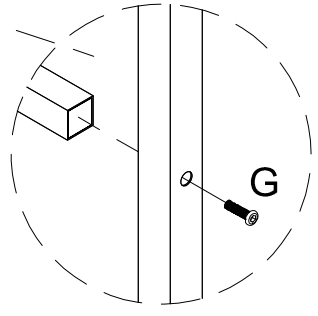
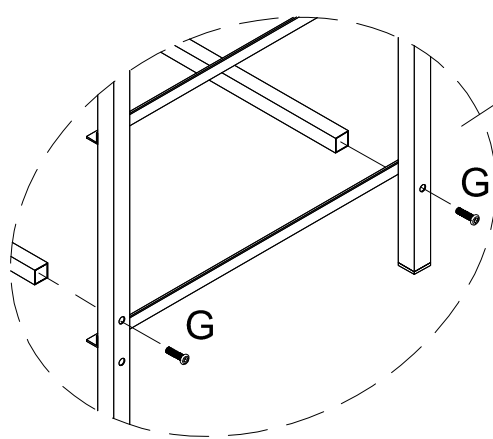
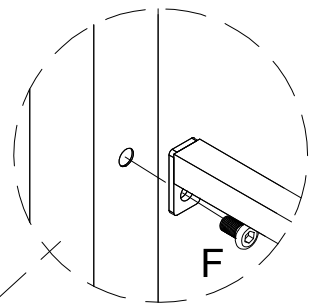
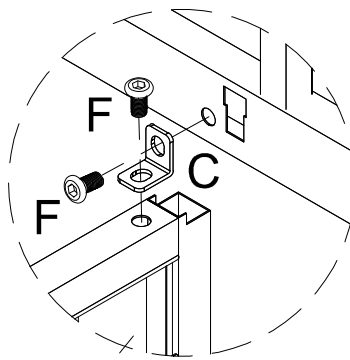
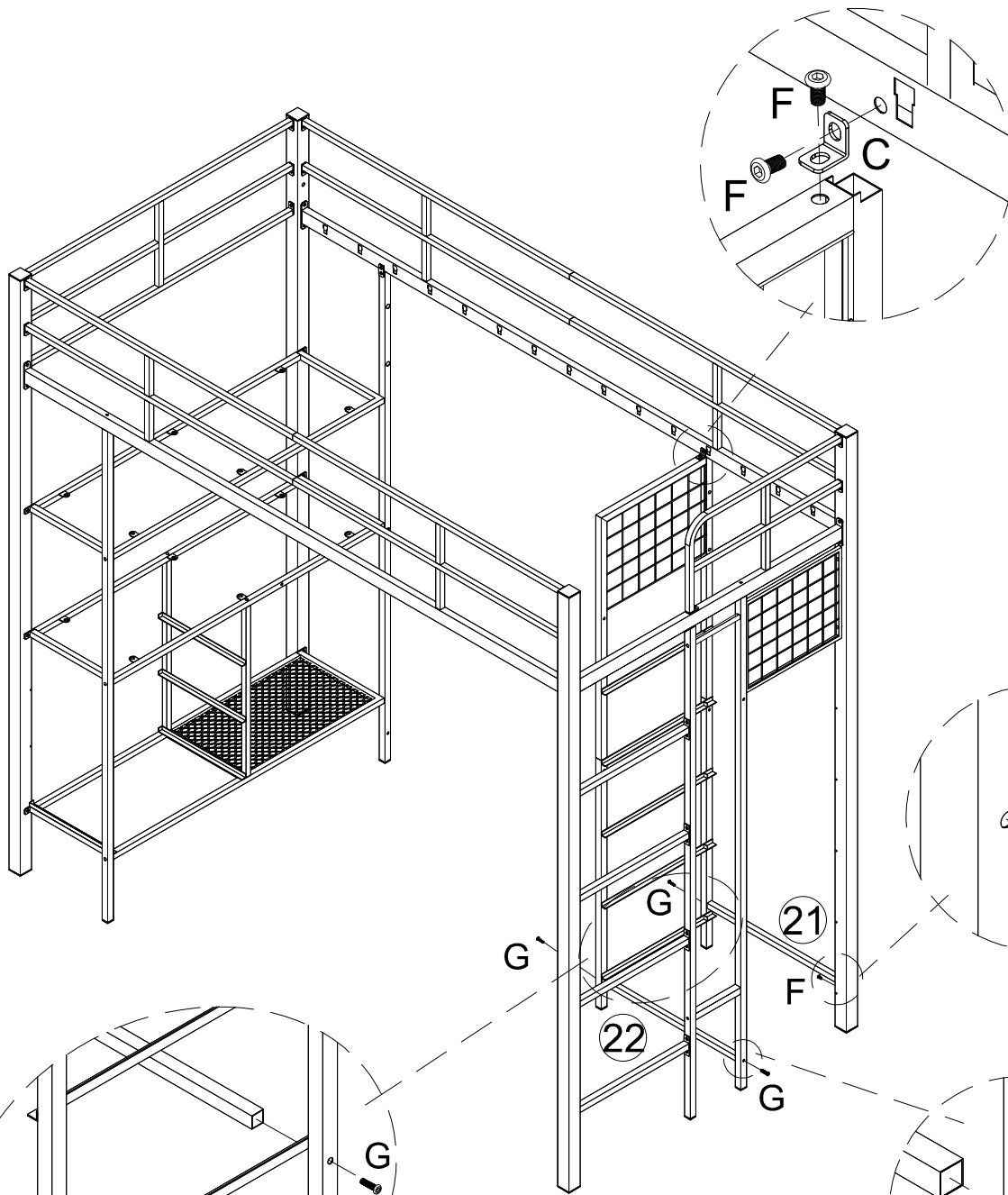
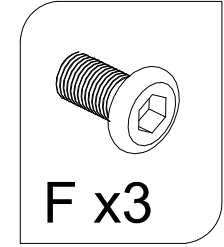
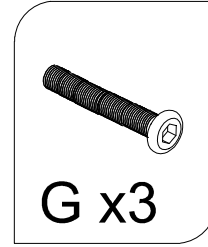

Step 16

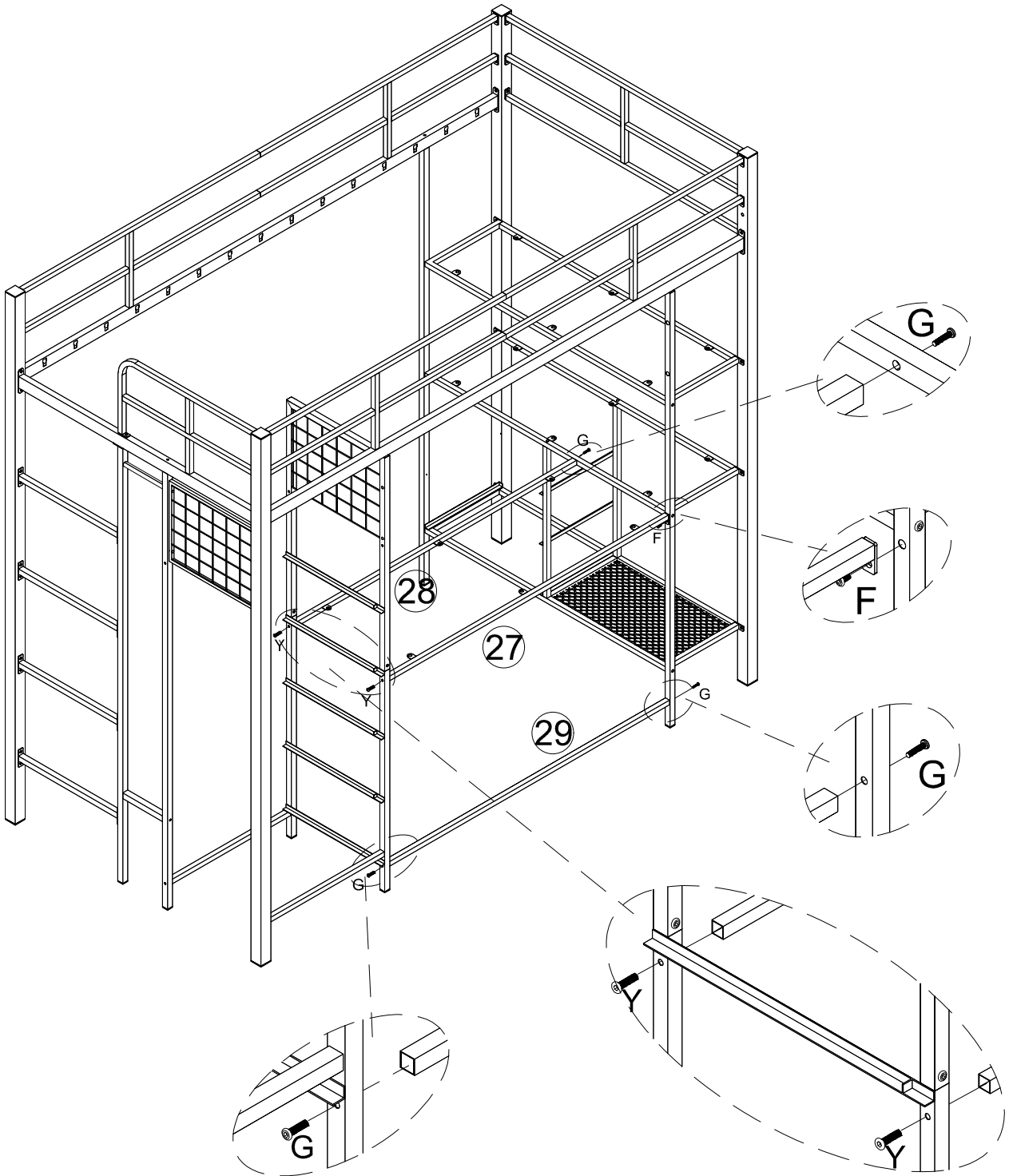
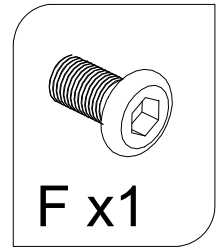
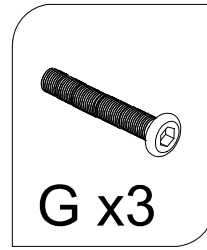
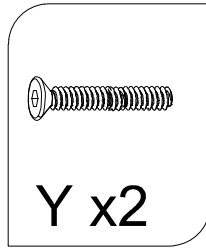

Step 17

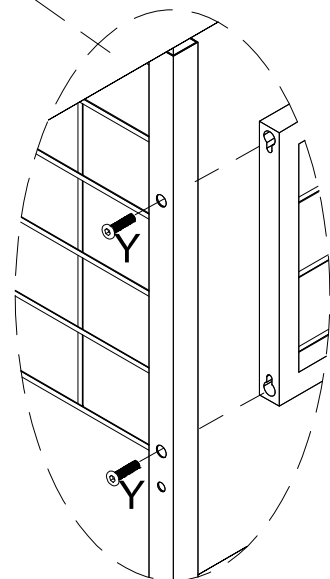
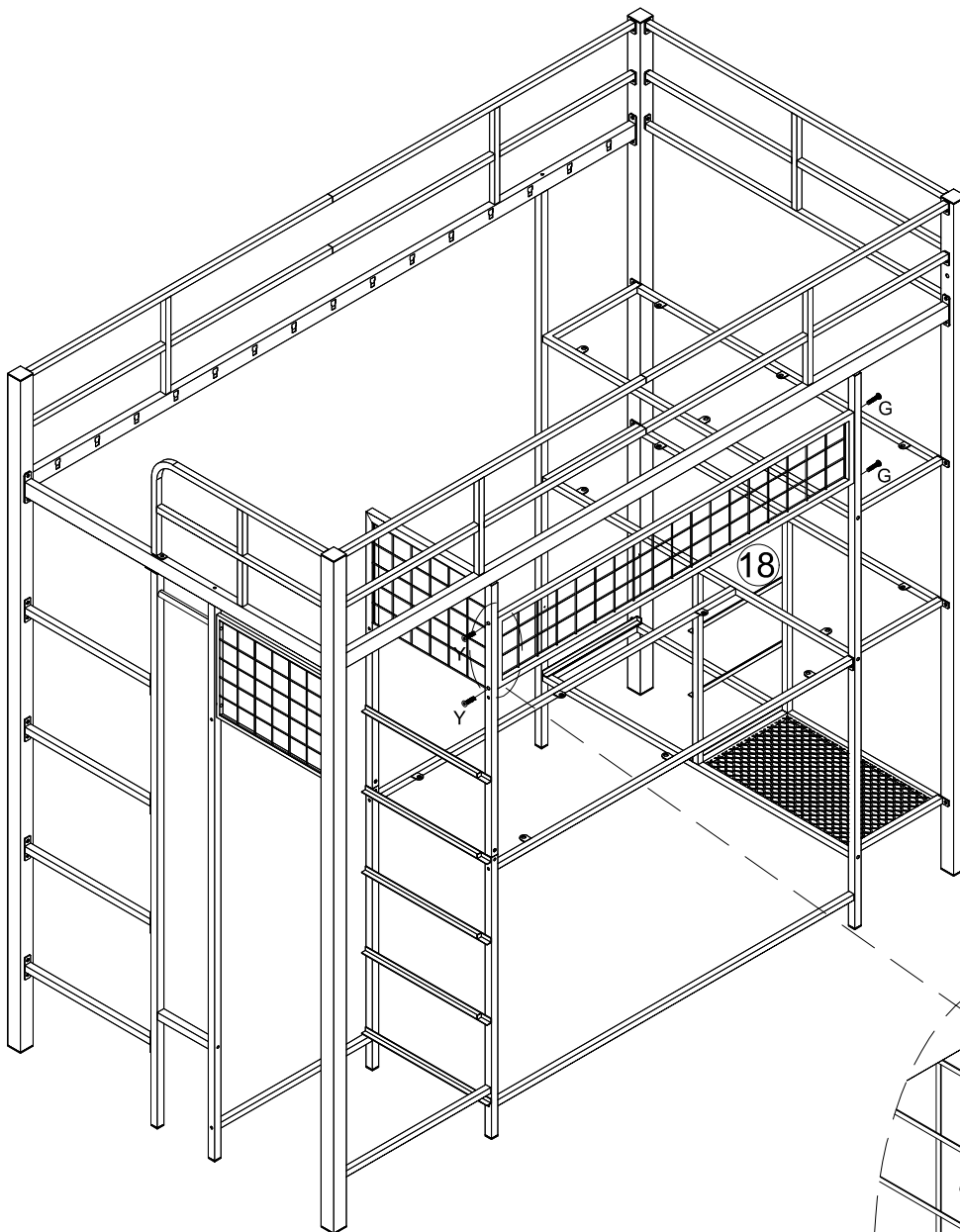
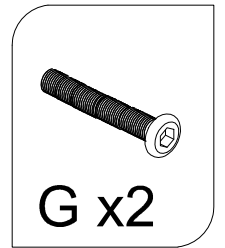
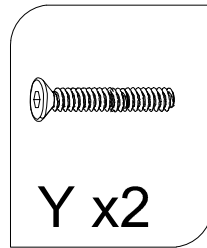

Step 18

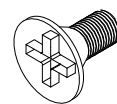

J x4

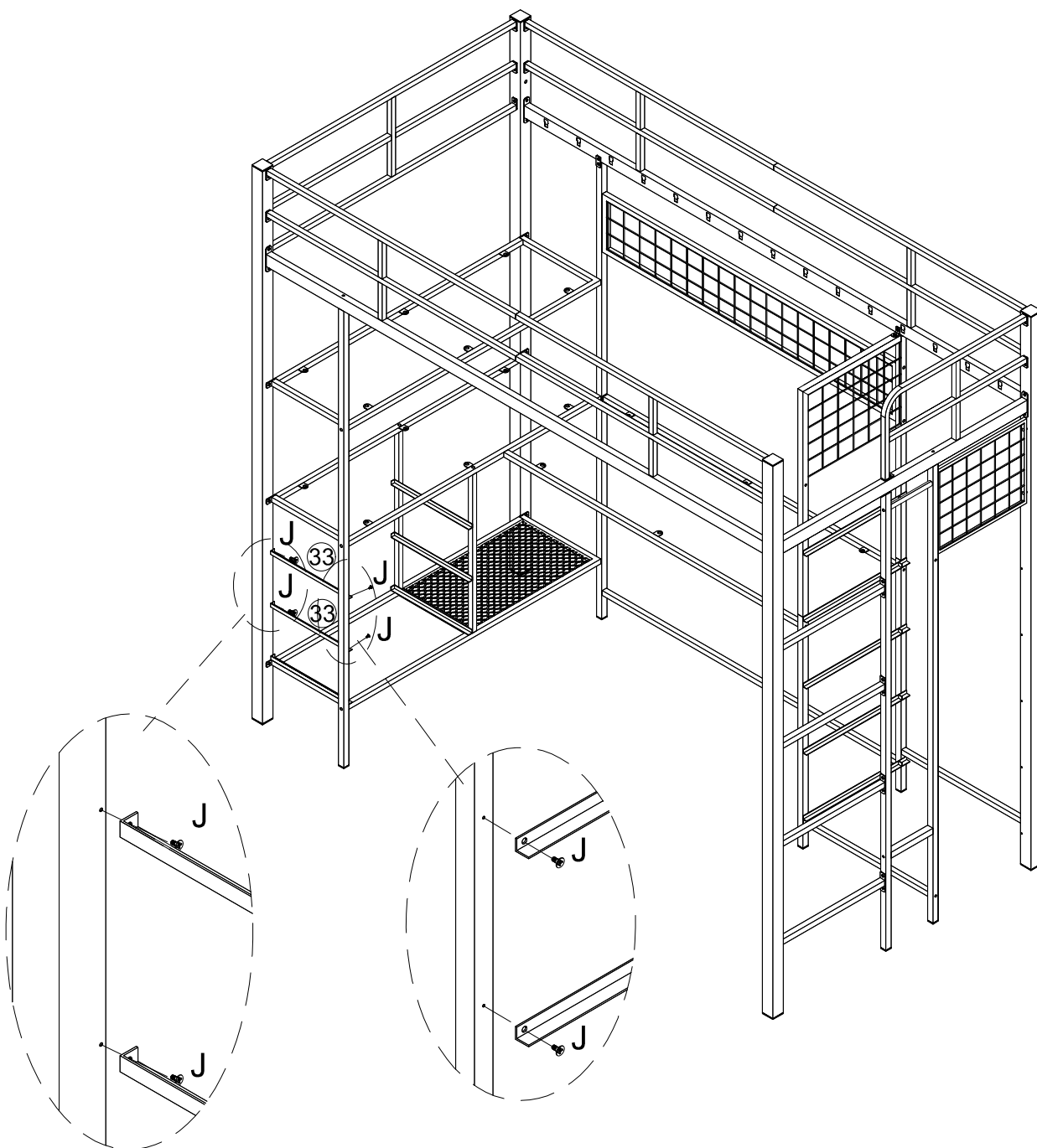

Step 19

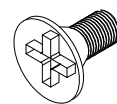

J x10

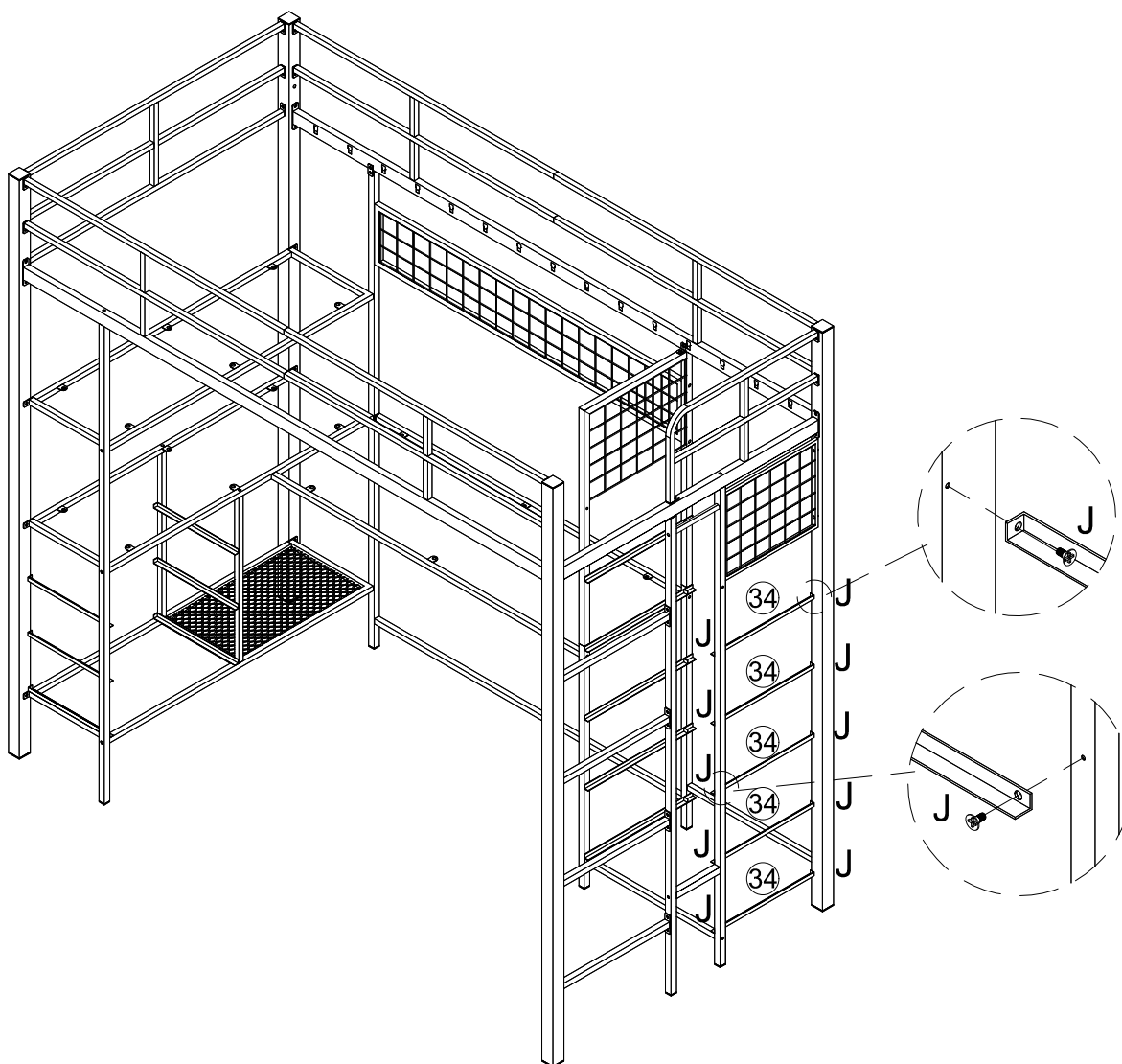

Step 20

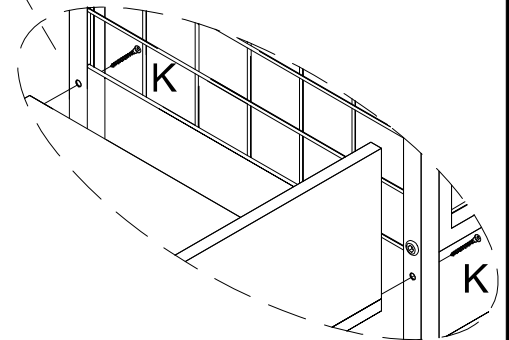
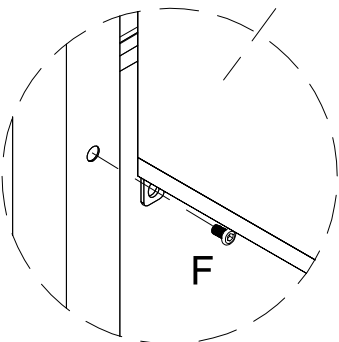
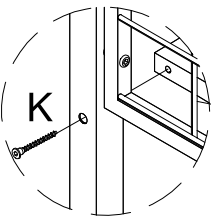
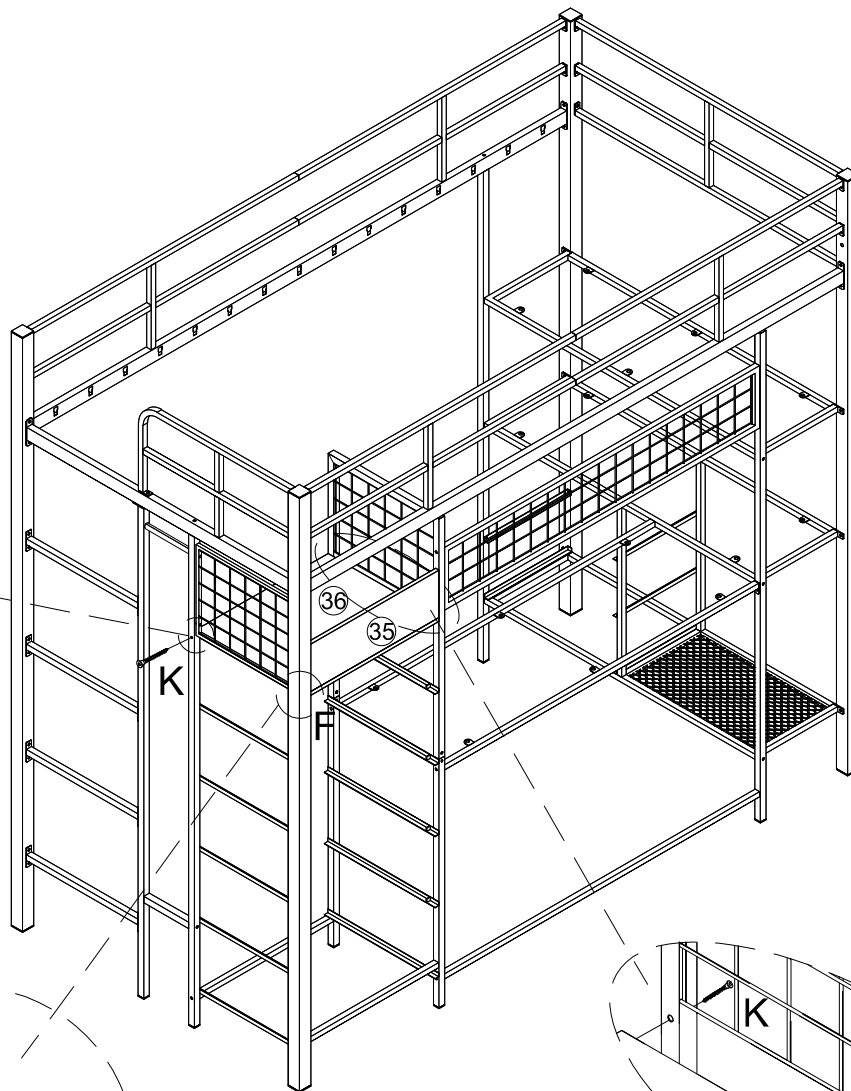
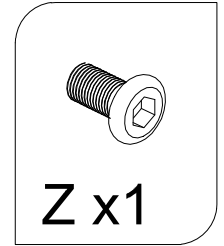
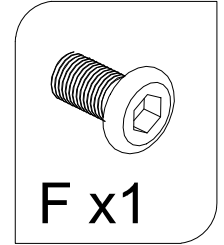
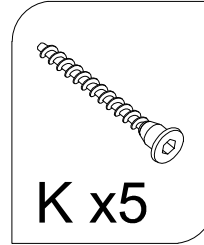
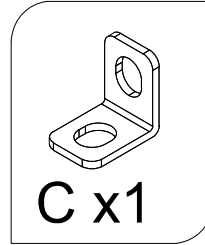
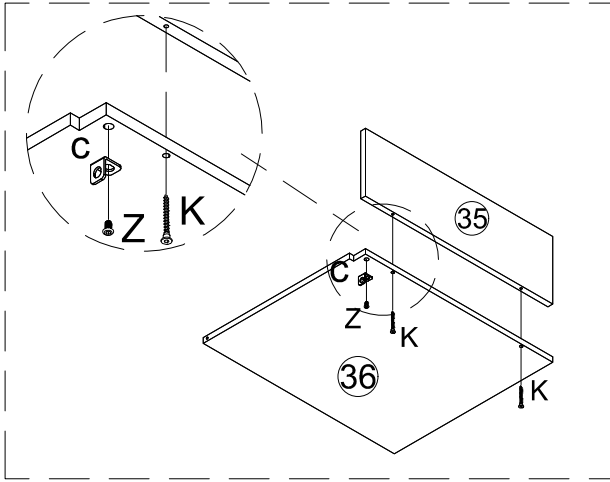

Step 21

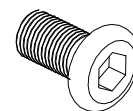

Z x6

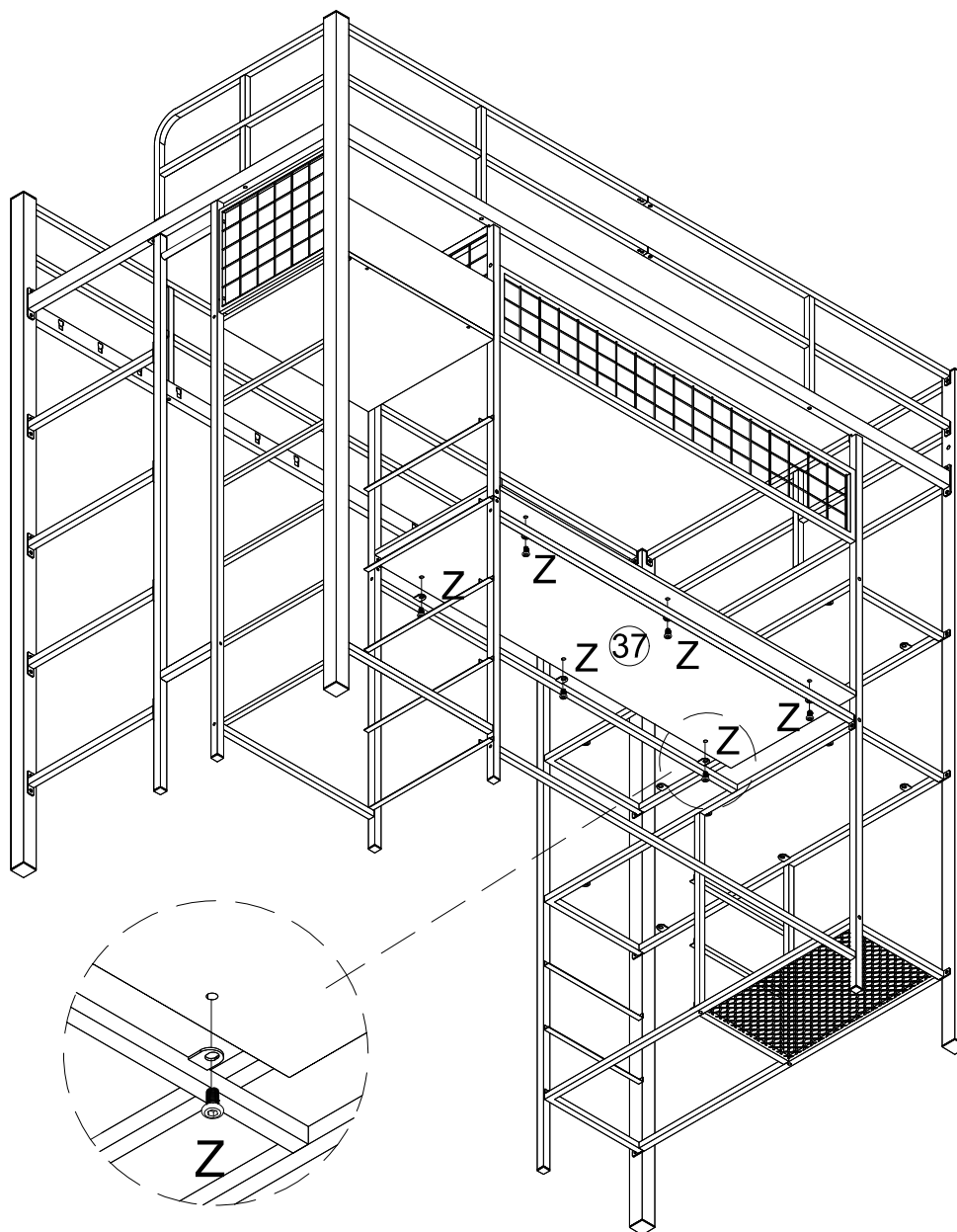

Step 22

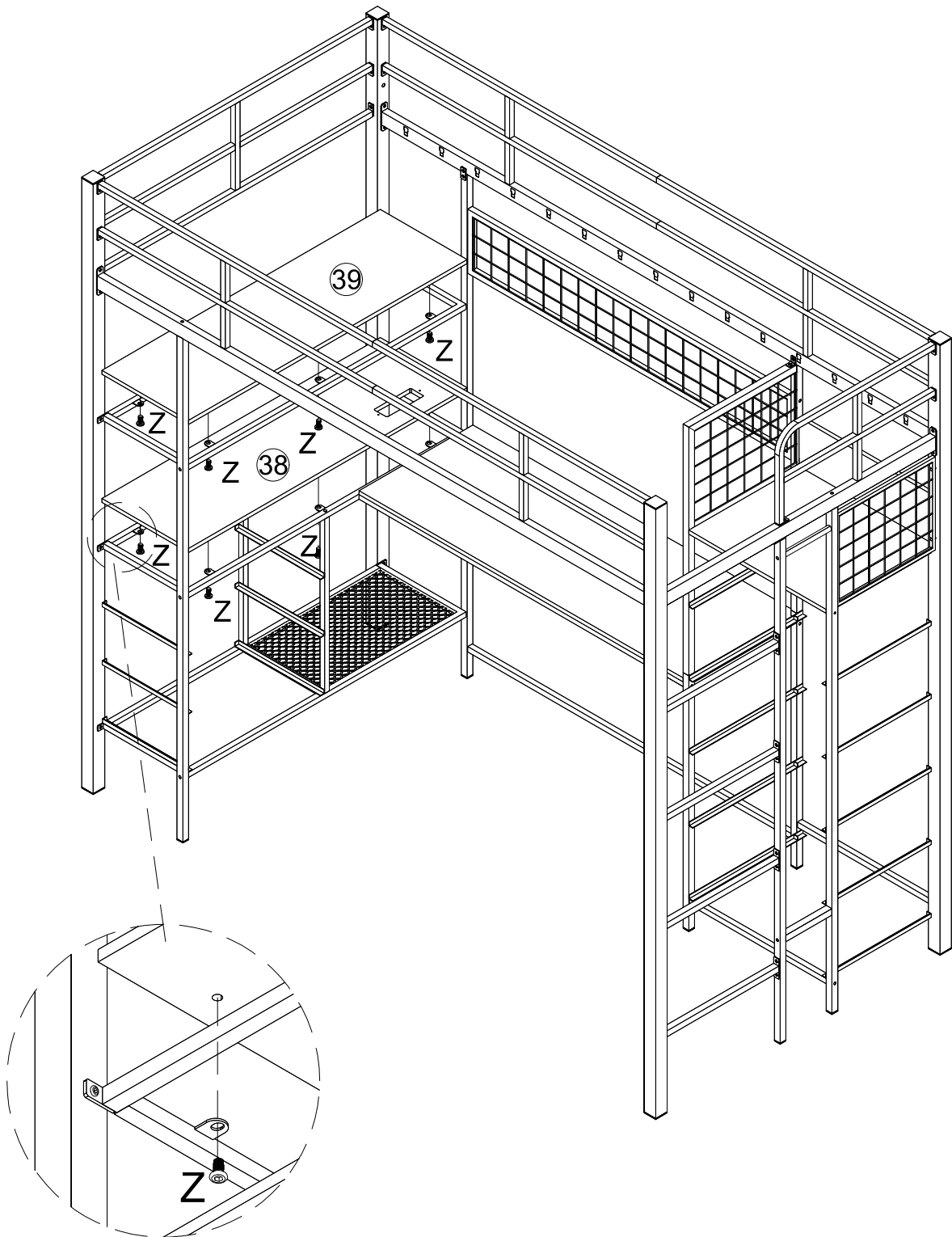
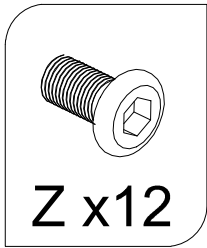

Step 23

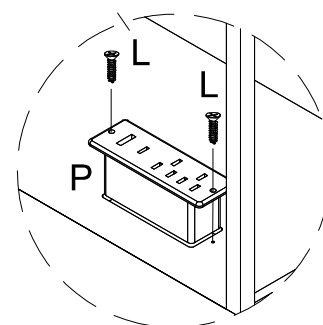
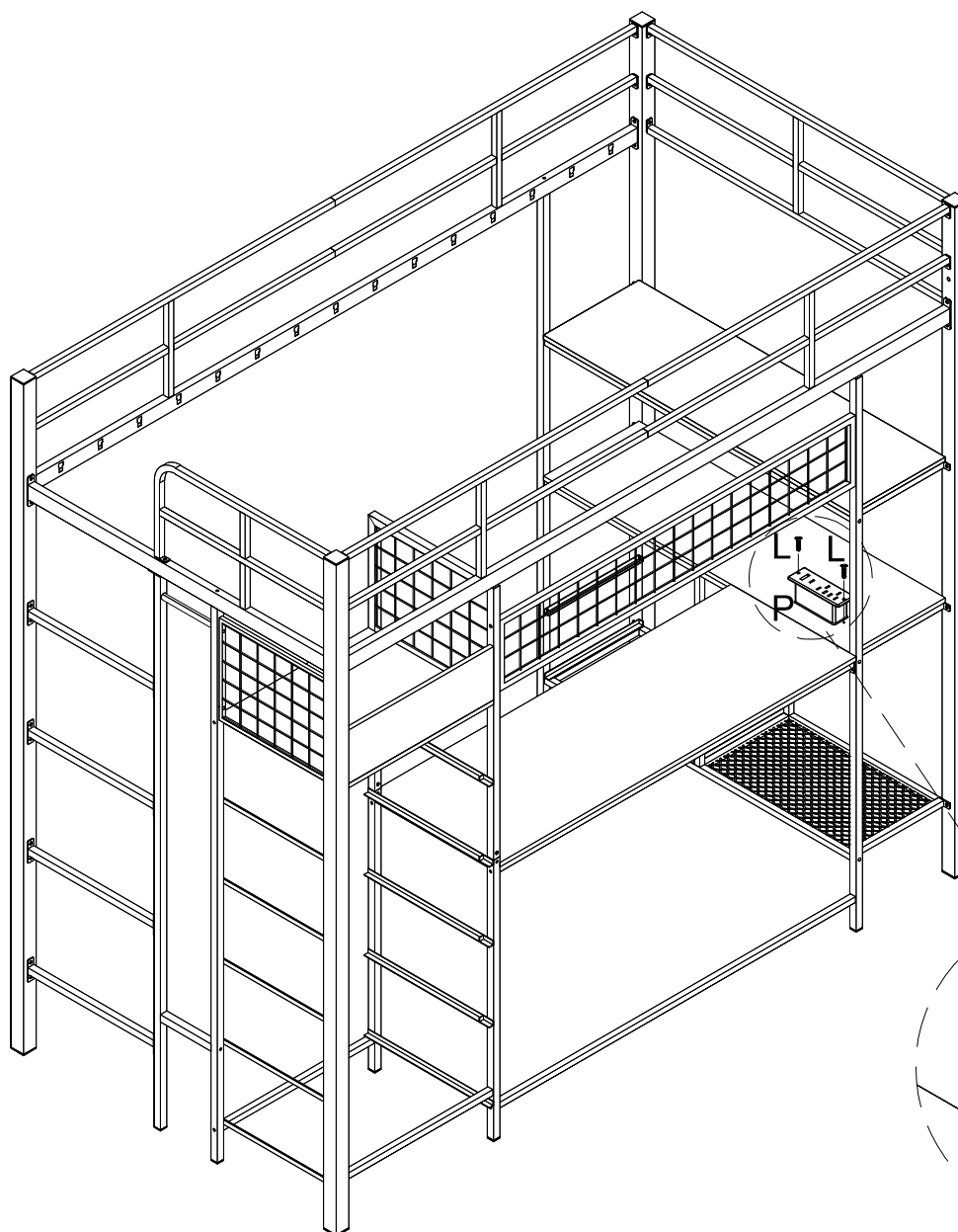
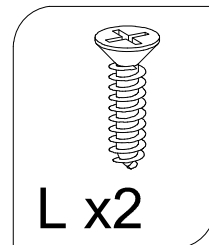
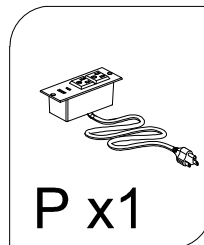

Step 24

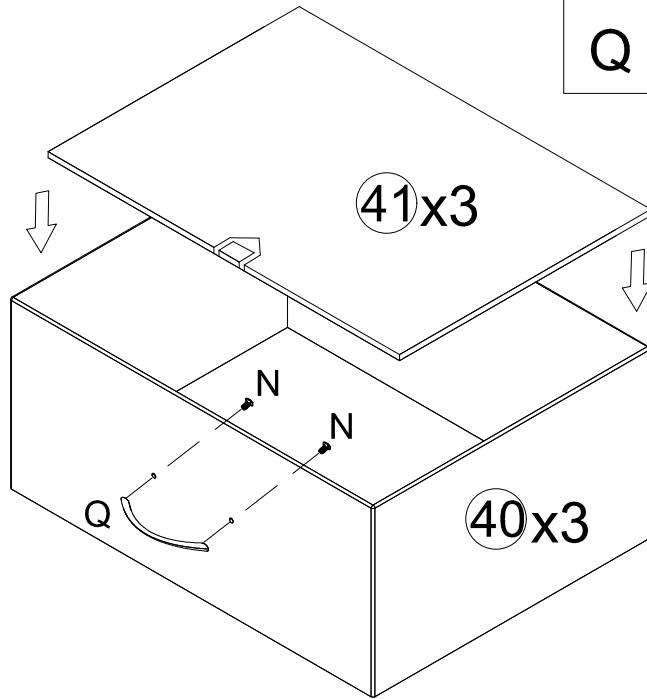
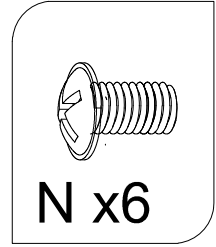
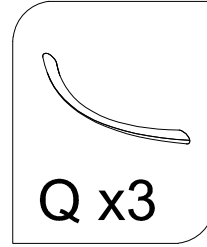

Step 25

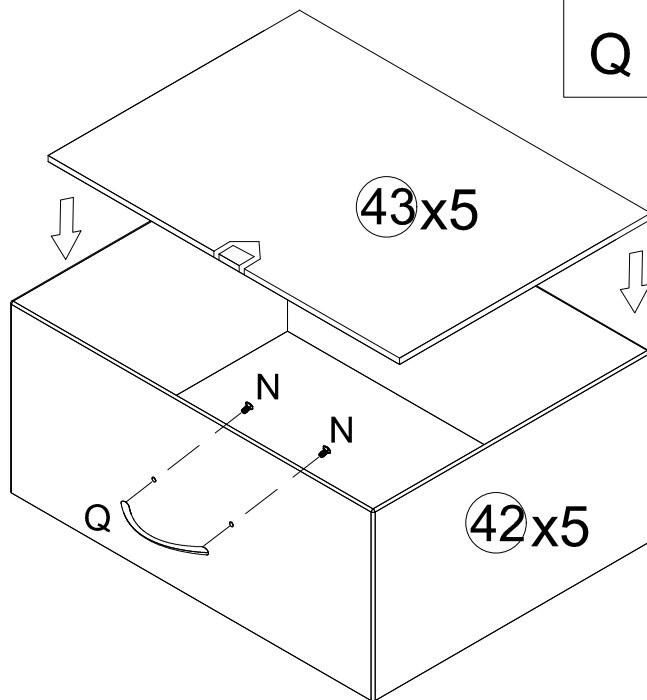
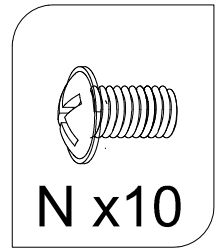
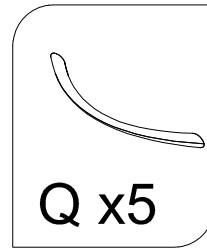

Step 26

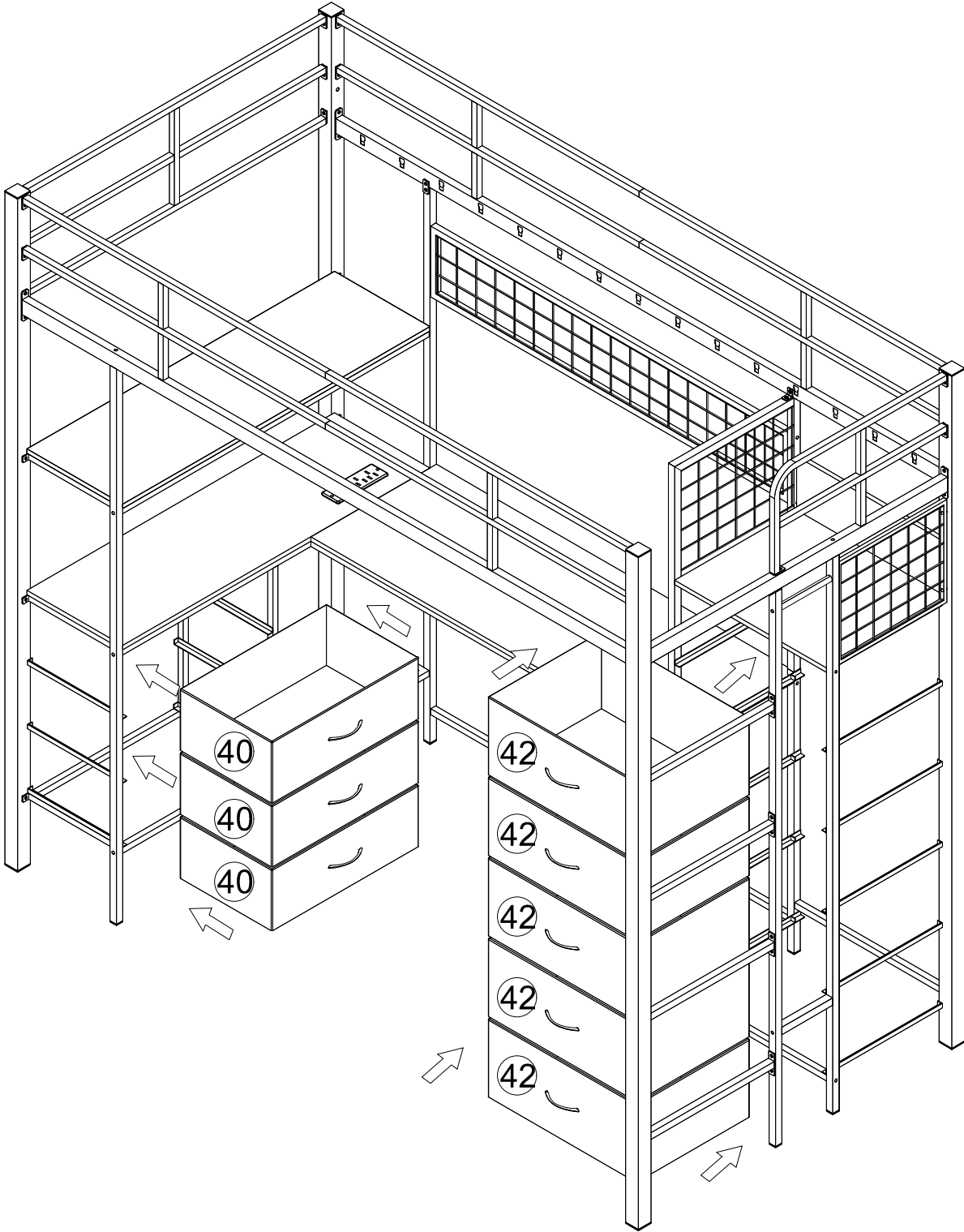

Step 27

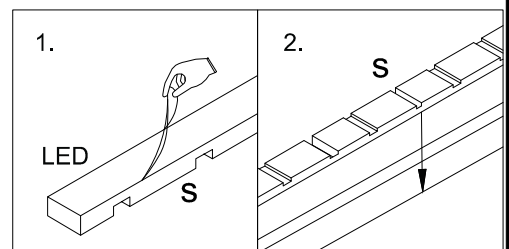
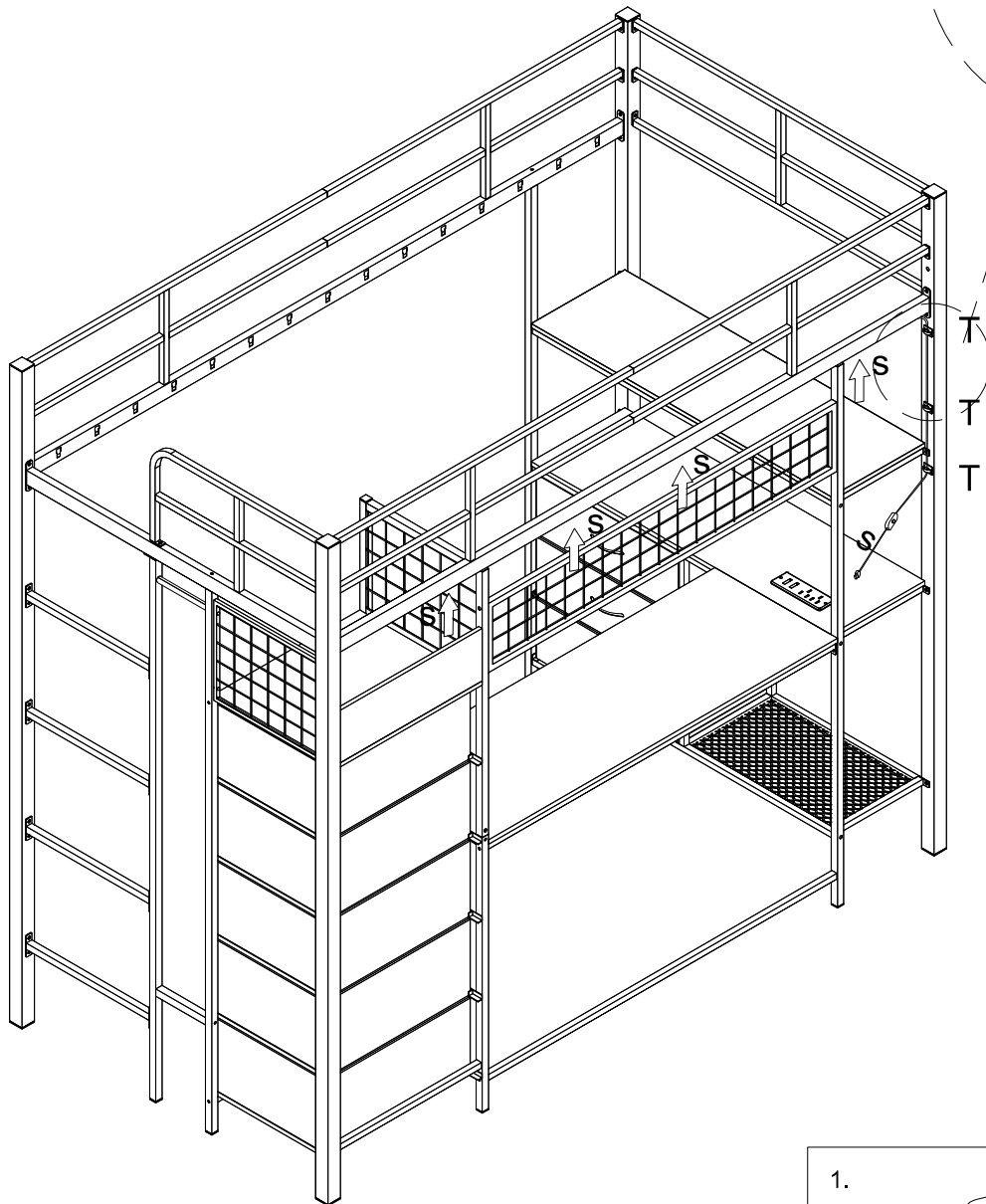
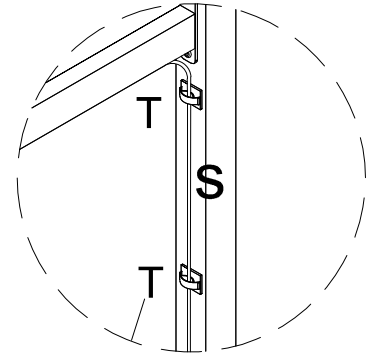
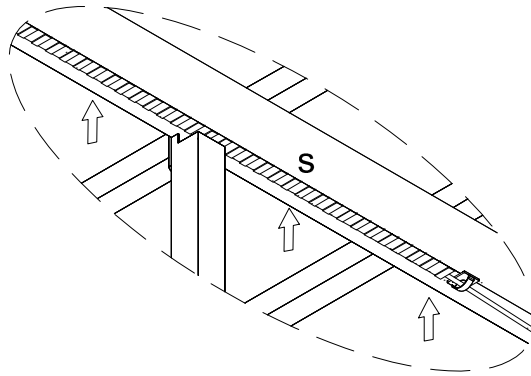
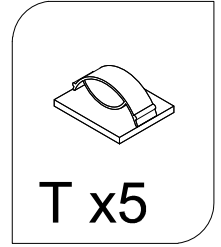
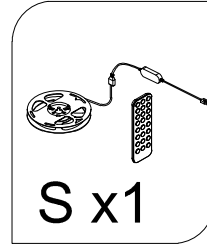

Step 28

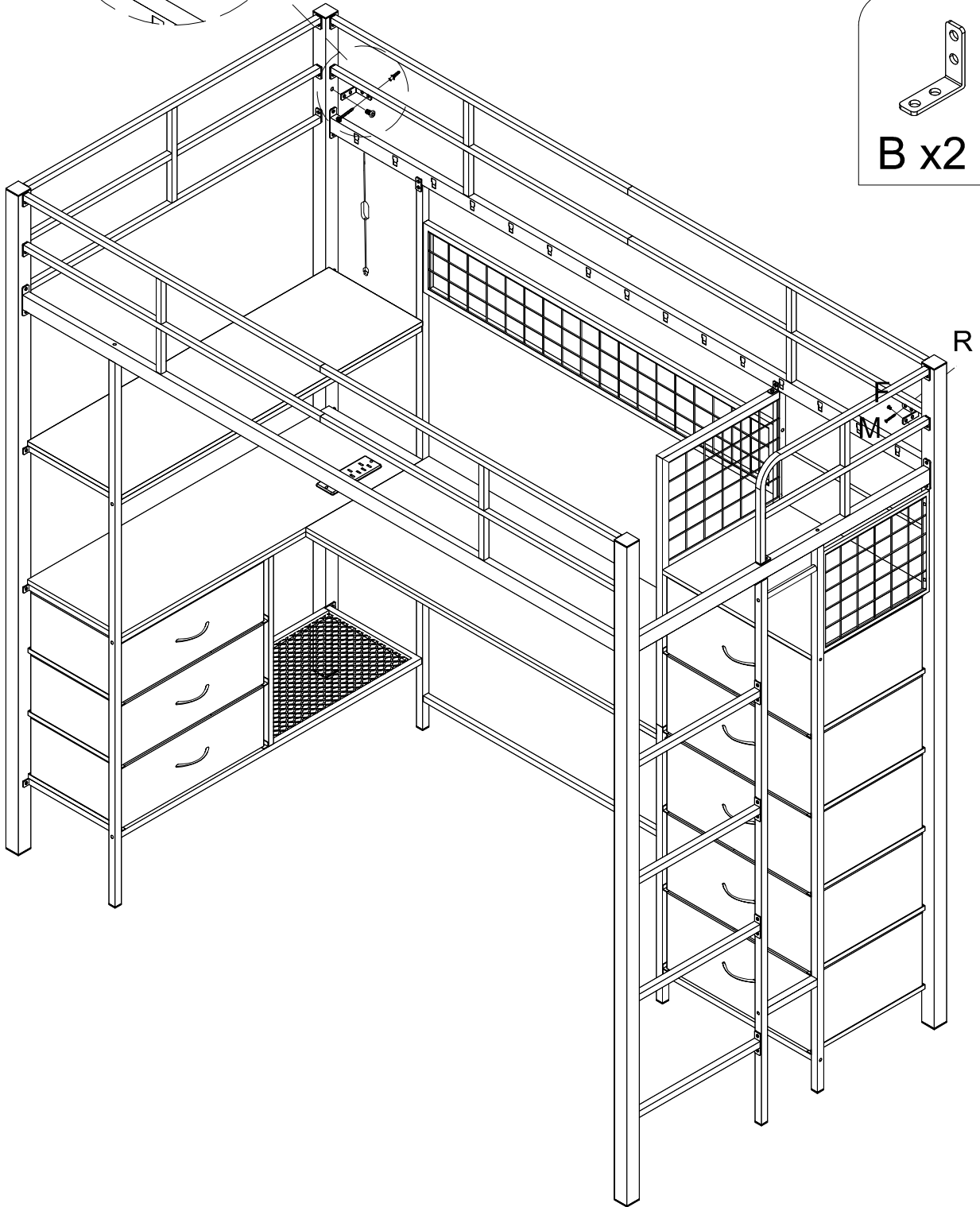
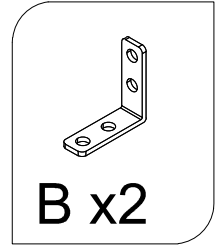
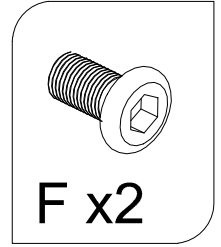
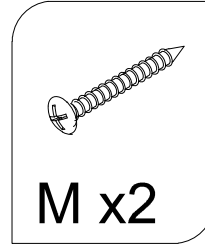
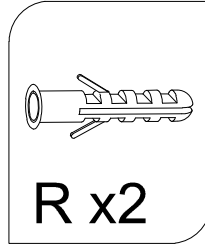
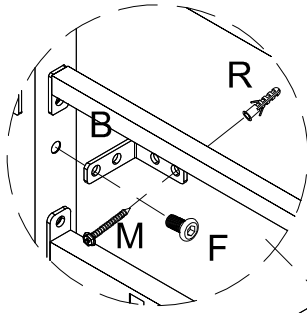

Step 29

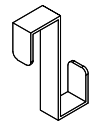

A x6

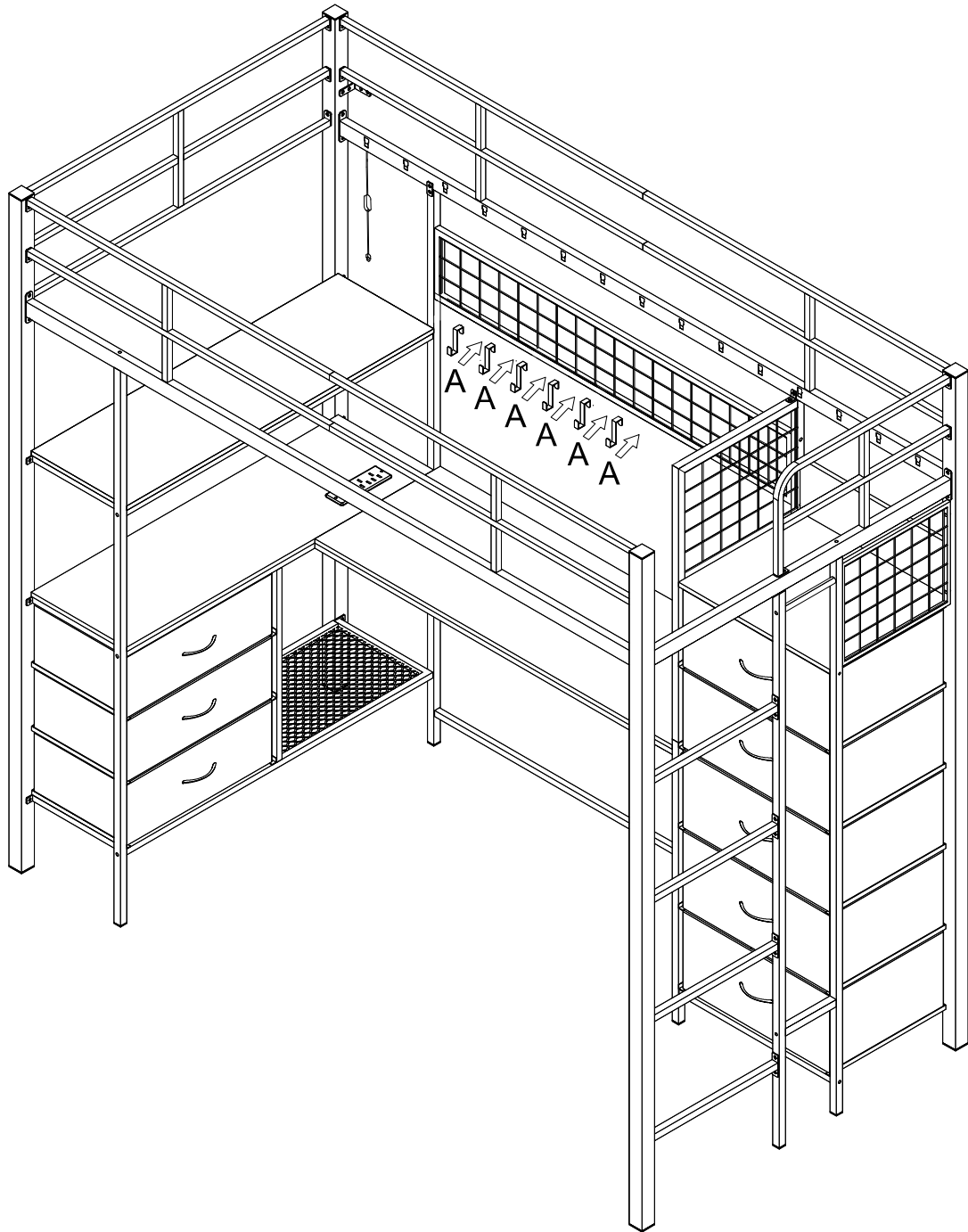

Step 30

