

Dual Speed In-Ground Swimming Pool Pump

Instruction Manual

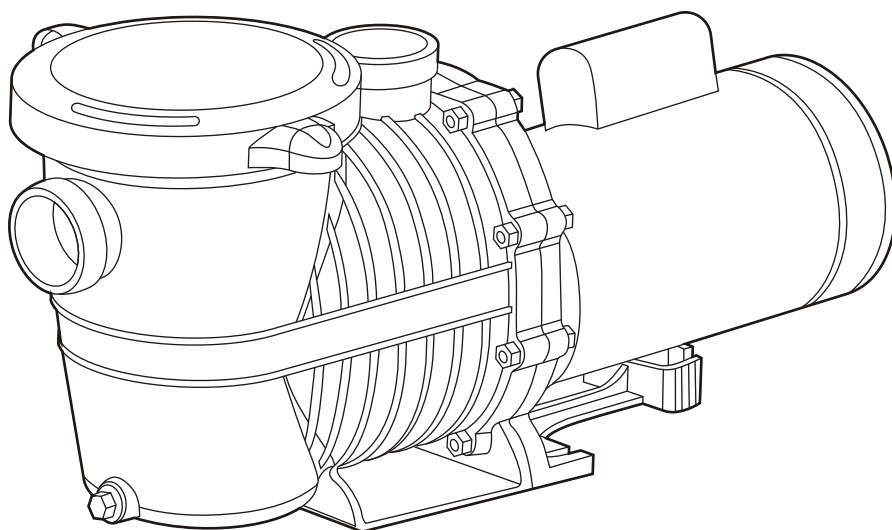

THIS INSTRUCTION BOOKLET CONTAINS IMPORTANT SAFETY INFORMATION.
PLEASE READ AND SAVE IT FOR FUTURE REFERENCE.

READ CAREFULLY AND SAVE THIS INSTRUCTION MANUAL





TO USER/INSTALLER/OPERATOR – THIS USER MANUAL INCLUDES KEY POINTS AND IMPORTANT SAFETY INSTRUCTIONS ON USING THIS PRODUCT, READ AND FOLLOW ALL INSTRUCTIONS. FAILURE TO DO SO MAY RESULT IN SERIOUS INJURY OR DEATH. SAVE THESE INSTRUCTIONS.

SAFETY PRECAUTIONS





Read this "Safety Precautions" before operation.

The below information should not be neglected for the proper use of this product. Following all instructions can help the user avoid potential danger.







The information below is very important for safety while handling this product.
Be sure to observe them carefully.

 DANGER	Indicates an imminently hazardous situation that will result in death or serious injury if not avoided
 WARNING	Indicates a potentially hazardous situation that will result in death or serious injury if not avoided.
 CAUTION	Indicates a potentially hazardous situation that will result in minor or moderate injury or property damage if not avoided.
IMPORTANT	 PROHIBITED  ALERT







DANGER

	Keep away from the main drain and all suction outlets.
	The strainer cover must be properly secured to prevent violent separation due to pressure in the circulation system.
	Before servicing, turn the power supply off and stop the system circulation, open the air relief valve and release all the pressure.
	It is highly recommended that this product be installed and serviced by a qualified pool professional.

WARNING

	Remove the plugs of the pool/spa from the suction outlets to avoid the potential for suction entrapment.
	To reduce the risk of injury, do not permit children to play with this product.
	Before starting, all system valves must be in a position that will allow pool water to return back to the pool.
	Do not operate the pool and spa circulation system if a system component is not assembled properly, damaged, or missing.
	Before working on any electrical equipment, turn off the power supply to the equipment.
	Connect only to a branch circuit protected by a ground-fault circuit interrupter (GFCI).

CAUTION

	All electrical wiring must be in conformance with applicable local codes, regulations, and the National Electric Code (NEC).
	It is strongly advised to protect the electrical components from direct sunlight though this pump is designed for outdoor use.
	Place this pump in a well-drained area, one that will not flood when it rains.
	If installed within an outer enclosure or beneath the skirt of a hot tub or spa, adequate ventilation and free circulation of air must be provided to prevent overheating.
	Do not install this pump in a damp or non-ventilated location. It requires free circulation of air for cooling.
	Do not run the pump dry. Water acts as a coolant and lubricant for the mechanical shaft seal. Running the pump dry may damage seals, causing leakage and flooding, thus avoiding warranty. Fill the strainer housing with water before starting the motor.

INSTALLATION

Before servicing, all water circulation systems and pump controls must be in the off position and release all the pressure from the system.

WARNING: This product should be installed and serviced by a qualified pool professional

Locate the pump as close to the pool and water level as possible. Do not add too many elbow pipes to the plumbing to avoid suction reduction. It is highly recommended that the pump be placed in a cool, dry place and avoid direct sunlight. Install the pump on a firm, level base or pad to meet all local and national codes. Fasten the pump to the base or pad with screws or bolts to further reduce vibration and stress on pipe or hose joints. The base must be solid, level, rigid, and vibration free.

It is also highly recommended to install a check valve on the pipe near the inlet port of the pump so that no priming is required when the pump restarts after that.

Warning: Prevent foreign matter from entering the pump through the inlet. Failure to do so will result in damage to the pump.

Warning: Keep product away from Children.

Use Teflon tape on the thread before screw fittings to pump inlet and outlet ports so as to avoid leakage. Do not over-tighten the fittings.

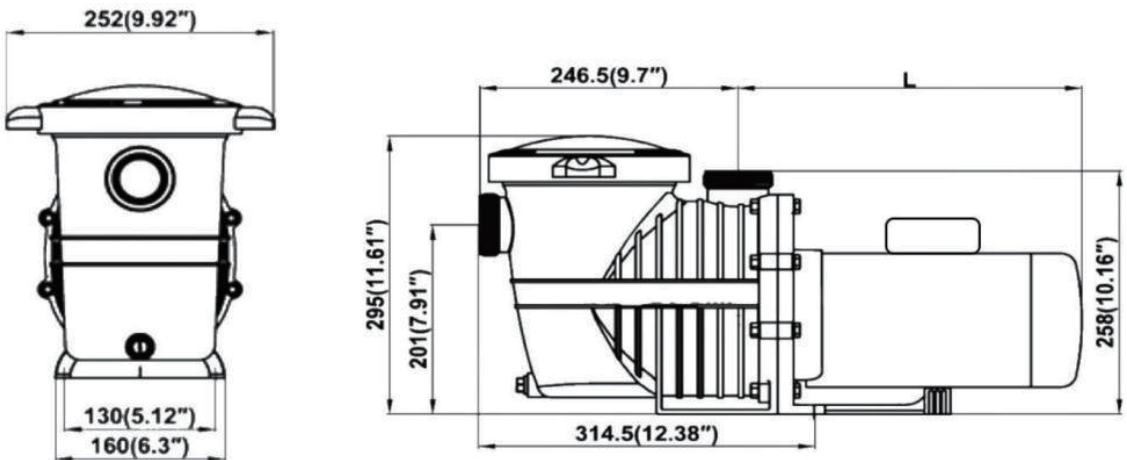

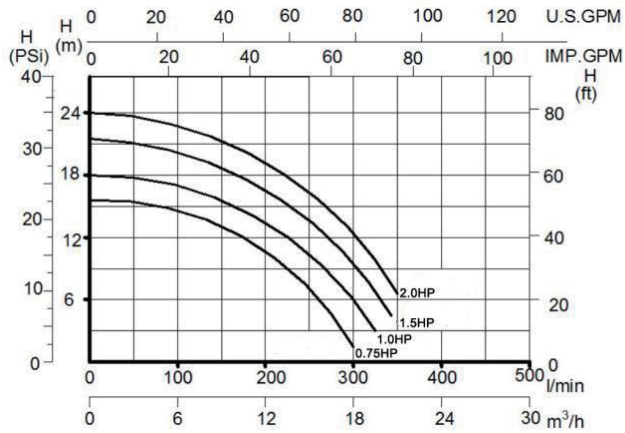

HP	0.75	1.0	1.5	2.0
L	12.36"(314mm)	13.11"(333mm)	13.58"(345mm)	14.17"(360mm)

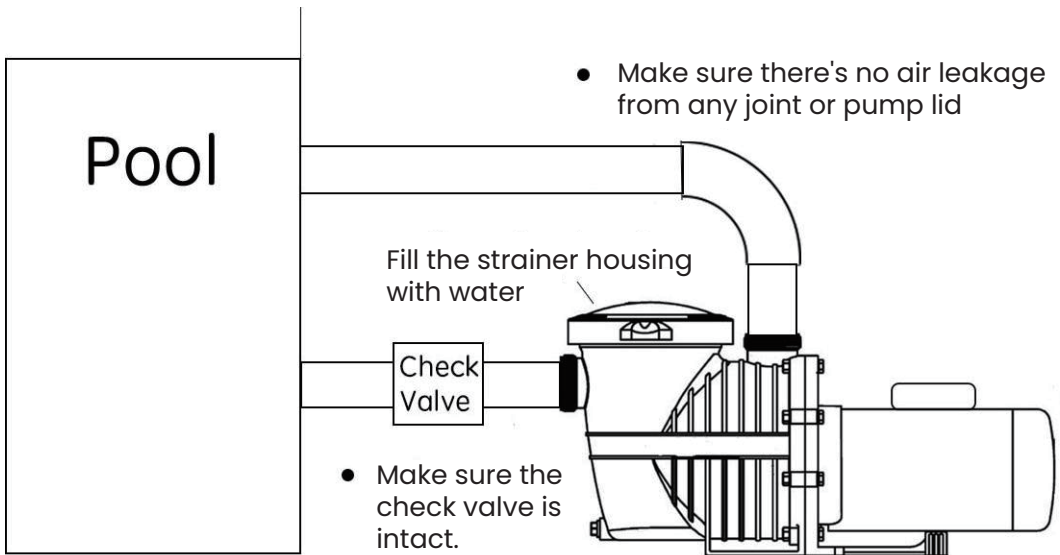

WIRING

Warning: All electrical wiring must conform to local codes, regulations, and the NEC.

Warning: Turn off the power to the pump before working on the electrical connections.

For Two Speed Pumps

If the pump comes with a power cord, no wiring is needed. If not, wire the pump as below:

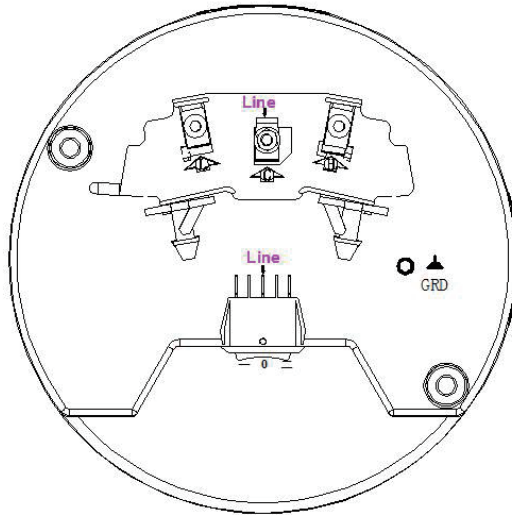

- 1) Ground wire connects to the ground terminal.
- 2) If your power supply has two hot wires, connect them to each terminal marked with "Line"; If your power supply has one hot wire and one neutral wire, connect either of them to either of the terminal marked with "Line".
- 3) Turn on the power and run the pump.

Make sure that the electrical supply available is suitable for the motor's voltage, phase, and cycle, and that the wire size is adequate for the HP (kW) rating and distance from the power source.

Warning: All electrical wiring must be performed by a licensed electrician.

Warning: All electrical wiring must conform to local codes and NEC regulations.

Warning: Use copper conductors only.

Electrical Guidance for 60Hz Single Phase Motors					
Rated		Volts	Circuit Breaker Amps	Branch Fusetron Amps	Recommended Wire Size 0-50'
KW	HP				
0.37	0.5	115	15	15	No.14
0.55	0.75	115 230	15 10	15 6.25	No.14 No.14
0.75	1	115 230	20 10	20 9	No.12 No.14
1.1	1.5	115 230	30 15	30 12	No.10 No.14
1.55	2	115 230	30 15	30 12	No.10 No.14
1.88	2.5	230	20	20	No.12

Voltage from the power must be in the range of 90% to 110% of the motor name-plate-rated voltage. Otherwise, the motor may overheat and result in overload tripping and reduced component life.

Install, ground, bond, and wire motor in accordance with local or NEC requirements. The motor should be grounded permanently by connecting the ground terminal to the electrical service ground.

Bond motor to pool structure. Bonding will connect all metal parts within and around the pool with a continuous wire. Bonding reduces the risk of current passing between bonded metal objects, which could potentially cause electrical shock if grounded or shorted.

PRIMING

Fill the strainer housing with water to the suction pipe level. If water leakage occurs from anywhere on the pump or filter, DO NOT start the pump. If no leakage occurs, stand at least 10 feet from the pump and/or filter and proceed with starting the pump. Turn on the power and wait for the pump to prime, which may take up to five (5) minutes. Priming time will depend on the vertical length of the suction lift and the horizontal length of the suction pipe. If the pump does not prime within five minutes, stop the motor and determine the cause. Make sure all suction and discharge valves are open when the pump is running. See the Troubleshooting Guide.

SERVICING

Warning: Stop the pump and release all pressure from the circulation system before servicing.

Check the status of the pump regularly. Clean the filter basket immediately if it is full of debris. Make sure the environment is ventilated enough for the motor to cool itself. If any problem is found on the pump, see the Troubleshooting Guide to determine the cause and contact the distributor to get spare parts for replacement. See Parts Guide.

STORAGE

To keep the pump from freezing in winter, please drain the pump properly:

- Keep the water level below the inlet of the pool.
- Pull out the drain plug from the pump strainer body and remove the strainer lid.
- Disconnect the pump from the mounting pad, wiring system, and piping system.
- Once water is drained off from the pump, reassemble the strainer lid and drain plugs.
- Place the pump in a shady and dry area.

Warning: Turn off the power and release all pressure before draining the pump.

TROUBLESHOOTING

ISSUE	POSSIBLE SOLUTION
MOTOR WILL NOT START	Wrong wiring; Loose electrical connection; Switches or relays not closed; Tripped circuit breakers, GFCI's, or blown fuses. No power supply or improper power supply.
	Open the motor back cover and rotate the shaft manually to make sure it is not trapped.
	If the pump connects to a timer, make sure it works.
MOTOR SHUTS OFF	Improper wiring; loose connections;
	Low voltage at motor or power drop (frequently caused by undersized wiring or extension cord use).
	Mechanical binding and electrical overload.
MOTOR HUMS BUT CAN NOT START	Centrifugal switch stuck in OPEN position.
	Trapped impeller or motor shaft.
PUMP WON'T PRIME	Make sure the pump strainer housing is filled with water and the cover O-ring is clean, also be sure it is properly seated in the cover O-ring groove. Make sure the strainer cover is locked firmly in position and properly lubricated.

ISSUE	POSSIBLE SOLUTION
PUMP WON'T PRIME	Make sure all suction and discharge valves are fully open and not blocked, that the pool water level is at a proper level and that the skimmer weir is not hung up or stuck on the skimmer wall.
	Block off to determine if the pump will develop a vacuum. You should have 5"–6" of vacuum at the strainer cover. You may be able to check by removing the skimmer basket and holding your hand over the bottom port with the skimmer full and pump running. If no suction is felt, check for line blockage.
	a. If the pump develops a vacuum, check for a blocked suction line or dirty strainer basket and an air leak in the suction piping may be the cause.
	b. If the pump does not develop a vacuum and has sufficient "priming water": i. Re-check the strainer housing cover and all threaded connections for suction leaks. Check if all hose clamps are tight. ii. Check voltage to ensure that the motor is rotating at full RPM. iii. Open the housing cover and check for clogging or obstruction in suction. Check the impeller for debris. iv. Remove and replace the shaft seal only if it is leaking.
LOW FLOW	Clogged or restricted strainer or suction line; undersized pool piping.
	Plugged or restricted discharge line or filter, valve partially closed (high gauge reading). How to correct: Sand filters – backwash as per manufacturer's instructions; D.E. filters – backwash as per manufacturer's instructions; Cartridge filters – clean or replace cartridge.
	Air leak in suction piping causing rumbling in the pump.
	Cavitation due to restricted or undersized suction line or leak at any joint, low water level in the pool, and unrestricted discharge return lines. Correct suction condition or throttle return lines, if practical. Holding hand over return fitting will sometimes prove this point or putting in a smaller eyeball fitting.
NOISY PUMP	Vibration due to improper mounting, etc. Put a rubber pad under metal mounting feet
	Foreign matter may be in the pump housing. Remove any loose stones/debris that may hit the impeller.
	Motor bearings are noisy from normal wear, rust, overheating, or the concentration of chemicals causes seal damage which will allow chlorinated water to seep into bearings wiping out the grease and causing the bearing to whine. All seal leaks should be replaced at once.
	Equipment base vibrating.

SPARE PARTS

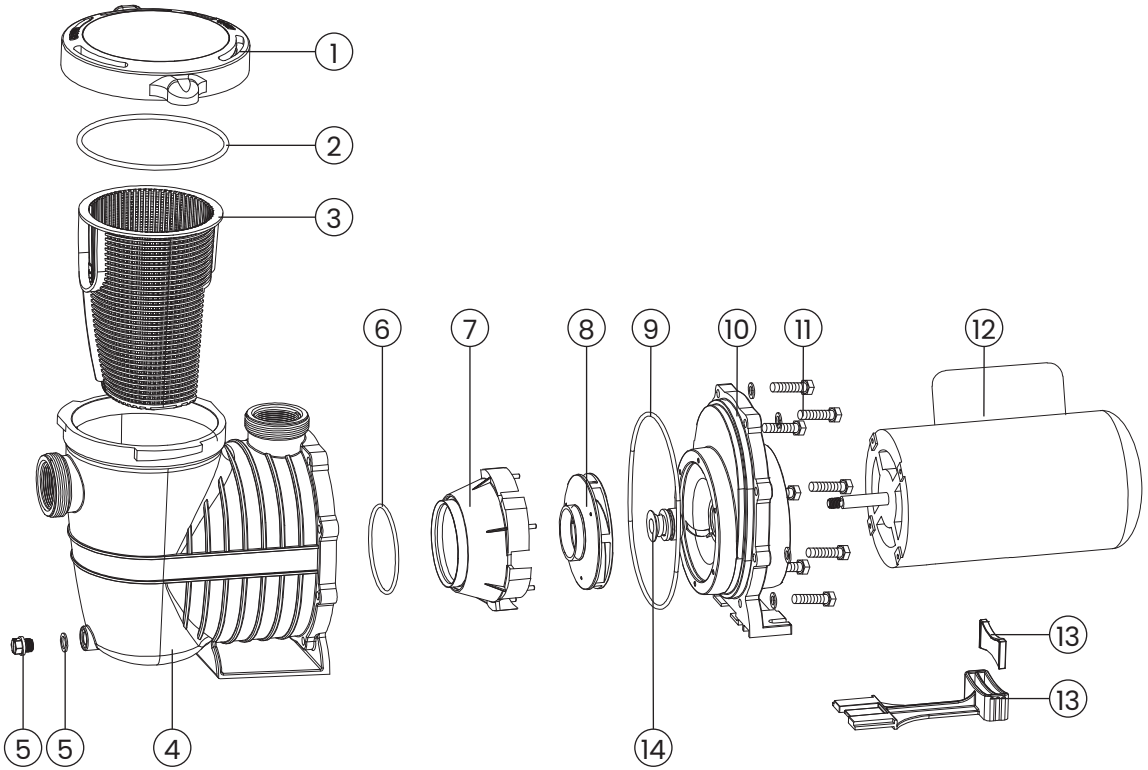

No.	Description
1	Lid
2	O-Ring
3	Basket
4	Strainer Casing
5	Drain Plug
6	Diffuser O-Ring
7	Diffuser

No.	Description
8	Impeller
9	Pump Casing O-Ring
10	Pump Housing
11	Screw
12	Motor
13	Carrier
14	Shaft Seal