



# ANLEITUNG

## Sehr geehrte Kundin, sehr geehrter Kunde,

vielen Dank, dass Sie sich für unser Produkt entschieden haben, mit dem Kauf eines unserer Markenprodukte haben Sie eine gute Wahl getroffen. Um den gewünschten hohen Qualitätsstandard zu erfüllen, unterliegen unsere Artikel regelmäßigen Kontrollen und entsprechen selbstverständlich stets den hohen Anforderungen der Europäischen Union.

## INHALTSVERZEICHNIS

SYMBOLE.....	2
ALLGEMEINE HINWEISE.....	2
BESTIMMUNGSGEMÄßE VERWENDUNG.....	3
AUSPACKHINWEISE.....	3
STANDORTAUSWAHL.....	4
HINWEISE ZUM AUFBAU.....	4
WARTUNGS- UND PFLEGEHINWEIS.....	4
ENTSORGUNG.....	5
TEILELISTE.....	6
TEILELISTE PC-PANEELE.....	8
AUFBAU DACHFENSTER.....	9
AUFBAU SCHIEBETÜR-RAHMEN.....	11
AUFBAU FRONT-RAHMEN.....	13
AUFBAU LINKE WAND.....	15
AUFBAU RECHTE WAND.....	17
AUFBAU RÜCKWAND-RAHMEN.....	19
RAHMEN DER WÄNDE MITEINANDER VERBINDEN.....	21
DACH-RAHMEN MONTIEREN.....	23
ANBRINGEN DER TRANSPARENTEN PC-PANEELE.....	25
MONTAGE VON SCHIEBETÜR UND REGENRINNE.....	27

## SYMBOLE



### BETRIEBSANLEITUNG LESEN. WICHTIGE HINWEISE. FÜR KÜNFTIGE VERWENDUNG AUFBEWAHREN!

Lesen Sie vor der ersten Verwendung die Anleitung vollständig und gründlich durch. Bewahren Sie diese Anleitung zum späteren Nachschlagen auf. Sollten Sie eines Tages das Produkt weitergeben, achten Sie darauf, auch diese Anleitung weiterzugeben.



### ACHTUNG! POTENTIELLE GEFAHR!

Beachten Sie die Sicherheitshinweise und Aufbauanweisungen, um das Risiko von Verletzungen oder Beschädigungen am Produkt zu vermeiden.



### ERSTICKUNGSGEFAHR!

Halten Sie kleine Teile und Verpackungsmaterial von Kindern fern!



### PRODUKTVERÄNDERUNG

Nehmen Sie niemals Änderungen am Produkt vor! Durch Änderungen erlischt die Gewährleistung und das Produkt kann unsicher bzw. schlimmstenfalls sogar gefährlich werden.

## ALLGEMEINE HINWEISE

- Wir empfehlen für den Aufbau eine Anzahl von mindestens 2 Personen.

- Wählen Sie einen Standort aus, der um das Gerätehaus herum genügend Platz zum Arbeiten bietet.
- Befolgen Sie die in der Anleitung vorgeschriebenen Schritte genau, um einen korrekten Aufbau zu gewährleisten.
- Vergewissern Sie sich vor Beginn der Montage, dass alle Teile vorhanden sind.
- Stellen Sie sicher, dass der Fundamentrahmen flach auf dem Boden liegt.
- Das Fundament muss eben sein. Falls der Boden uneben sein sollte, nivellieren Sie ihn.
- Ihr Gewächshaus muss fest am Fundament verankert sein, um Beschädigung durch starken Wind zu verhindern.
- **ACHTUNG!** Betreten Sie nicht das Dach! Einsturzgefahr!
- Bei Verwendung eines nicht aus Beton gegossenem Fundament müssen Sie unbedingt beachten, dass der Untergrund fest und eben ist. Das Produkt muss mit/in einem Fundament befestigt sein! Das Gewächshaus wird nur dauerhaft und stabil stehen können, wenn es genau ausgerichtet ist. Schon bei leicht schiefstehenden Wänden können diese nicht mehr ordnungsgemäß in den vorgesehenen Führungen gehalten werden und können vom Wind leicht aus den Angeln gehoben werden.
- Das Fundament des Gewächshauses muss unbedingt im Boden verankert/fixiert werden. Die große Fläche des Gewächshauses bietet eine große Angriffsfläche für den Wind, dadurch kann es zu erheblichen Verletzungen und/oder Sachschäden kommen.
- Machen Sie niemals Feuer in dem Gewächshaus und halten Sie es von offenem Feuer und Funken fern!
- Verwenden Sie dieses Produkt nicht, wenn Teile fehlen, beschädigt oder abgenutzt sind.
- Achten Sie unbedingt darauf, keine Menschen und/oder Tiere im Gewächshaus einzusperren!
- Vermeiden Sie so gut wie möglich überhängende Bäume, da herabfallende Blätter eine regelmäßige Reinigung erforderlich machen und abbrechende Äste eine Gefahrenquelle darstellen.
- Kleine Bäume, Sträucher oder Zäune in der Nähe können als Windschutz hilfreich sein.
- **WARNUNG!** Bei Wind und Sturm müssen die Türen und Fenster geschlossen werden.

### **BESTIMMUNGSGEMÄßE VERWENDUNG**

Das Gewächshaus ist zum Anbau und zur Aufzucht von Gemüse, Blumen und anderen Pflanzen konzipiert. Das Gerätehaus eignet sich nicht zur Lagerung von Gefahrstoffen und zur Unterbringung von Personen oder Tieren. Verwenden Sie das Produkt nur für seinen vorgeschriebenen Zweck. Für entstandene Schäden aufgrund einer nicht bestimmungsgemäßen Verwendung übernimmt der Hersteller keine Haftung. Jegliche Modifikation am Produkt kann die Sicherheit negativ beeinflussen, Gefahren verursachen und führt zum Erlöschen der Gewährleistung.

**Nur für den Hausgebrauch und nicht für gewerbliche Nutzung.**

### **AUSPACKHINWEISE**

Öffnen Sie den Karton und nehmen Sie alle Teile und Elemente des Sets heraus und platzieren Sie die Komponenten auf der Oberseite des Kartons oder einer anderen sauberen Oberfläche. Dies schützt Ihr neues Produkt. Prüfen Sie das Produkt nach dem Auspacken auf Vollständigkeit oder Beschädigungen. Spätere Reklamationen können nicht akzeptiert werden.

## **STANDORTAUSWAHL**

Bevor Sie mit dem Aufbau beginnen, machen Sie sich mit den lokalen Bestimmungen und Verordnungen vertraut. Achten Sie bei der Auswahl des geeigneten Ortes für das Aufstellen des Gewächshauses auf einen stabilen, geraden Platz als Untergrund und achten Sie unbedingt darauf, dass keine exponierte Stelle gewählt wird, wo das Gerätehaus vollständig freisteht! Ein gewisser Schutz vor Stürmen und stürmischen Böen muss gewährleistet sein. Freistehend wird es sonst zu einem Schaden kommen.

## **HINWEISE ZUM AUFBAU**

Folgen Sie hierzu den Grafiken der Aufbauschritte.



Tragen Sie während der Montage immer Sicherheitshandschuhe, lange Ärmel und Augenschutz. Einige Teile können möglicherweise scharfe Kanten aufweisen und Verletzungen verursachen!

- Vor dem Errichten des Gewächshauses sollte unbedingt ein geeignetes Fundament entsprechend vorbereitet sein. Solche Fundamente (Schalungshilfen) können Sie bei uns im Onlineshop erwerben.
- Bauen Sie das Gewächshaus nicht bei Wind oder Nässe auf.
- Entnehmen Sie die Teile aus dem Karton und sortieren Sie sie nach den Nummern. Vergewissern Sie sich, dass alle notwendigen Teile für den Aufbau vorhanden sind.
- Machen Sie sich mit der Funktionsweise aller Werkzeuge vertraut.
- Halten Sie Kinder und Haustiere vom Montageort fern.
- Wenn Sie eine Leiter verwenden, achten Sie auf deren stabilen Stand. Bitte niemals mit vollem Gewicht auf irgendein Teil des Daches oder Gewächshauses stellen.
- Einige Montageschritte erfordern zwei Personen.
- Bewahren Sie Kleinteile (Schrauben usw.) in den Kartons und Tüten auf, damit sie nicht verloren gehen.
- Jedes Teil ist nummeriert und die entsprechende Nummer finden Sie in der Montageanleitung.
- Beginnen Sie mit der Montage, indem Sie die Teile mit der gleichen Nummer in eigenen Gruppen um den Aufstellungsort herum anordnen.
- Der Aluminiumrahmen des Gewächshauses wird zuerst aufgebaut und die PC-Paneele werden als letztes eingesetzt.

## **WARTUNGS- UND PFLEGEHINWEIS**

- Verwenden Sie zur Reinigung einen Schwamm und warmes Seifenwasser. Verwenden Sie keine lösungsmittelhaltigen Reiniger oder Waschmittel, z. B. Bleichmittel können das Produkt beschädigen.
- Nutzen Sie bei allen Arbeiten am Gewächshaus immer geeignetes Werkzeug.
- Tauschen Sie beschädigte Einzelteile des Gewächshauses umgehend aus! Menschen und Tiere können sich an beschädigten Teilen verletzen!







- Achten Sie unbedingt darauf, das Dach im Winter möglichst schneefrei zu halten. Es kann unter einer zu hohen Schneedecke einbrechen. Eine Schneehöhe von mehr als 10 cm kann bereits gefährlich werden (Schichthöhen von 36 cm bei trockenem Schnee, 10 cm bei wässrigem Schnee und 5,5 cm bei Eis entsprechen einem Gewicht von ca. 50 kg/m<sup>2</sup>).
- Bei unvorhergesehenen Problemen wenden Sie sich an unser Service-Team. Wir helfen Ihnen gerne.



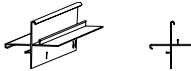

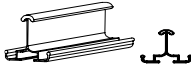



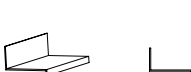
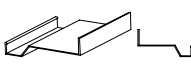
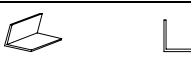



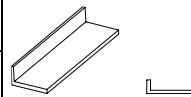
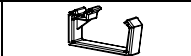
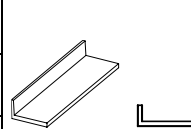
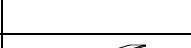

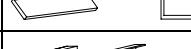

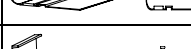
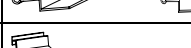
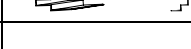
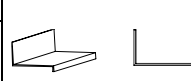

## **ENTSORGUNG**



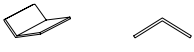
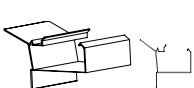
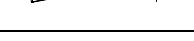
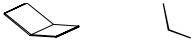



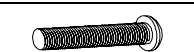
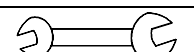

Am Ende der langen Lebensdauer Ihres Artikels führen Sie bitte die wertvollen Rohstoffe einer fachgerechten Entsorgung zu, so dass ein ordnungsgemäßes Recycling stattfinden kann. Sollten Sie sich nicht sicher sein, wie Sie am besten vorgehen, helfen die örtlichen Entsorgungsbetriebe oder Wertstoffhöfe gerne weiter.

## TEILELISTE (Karton 1/2)

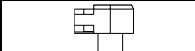
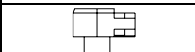

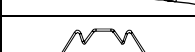

Nr.	Abbildung	Menge	Maße (mm)
1		4	1215
2		1	1134
3		1	1134
4		1	1134
5		1	1134
6		1	1647
7		1	1647
8		1	1655
9		1	1655
10		4	1215
11		4	1114
12		1	610
13		4	
14		1	1260
15		1	634
16		2	911
16A		1	170
17		1	1355
17A		1	467
17B		1	170





Nr.	Abbildung	Menge	Maße (mm)
18		2	
19		1	380
20		2	1608
21		4	1220
21A		4	610
21B		2	
22		4	1350
22A		2	1362
23		2	594
24		1	610
25		2	1304
26		2	610
27		1	610
28		2	520
29		1	608
30		1	595
31		1	595
32A		2	1432
32B		2	390
32C		2	170

Nr.	Abbildung	Menge	Maße (mm)
33		1	1433
33A		1	388
33C		1	170
34A		2	1433
34B		2	390
34C		2	170
35		5	603
36		2	
37		1	
38		1	M5x30
39		2	
40		138	M6x10

Nr.	Abbildung	Menge	Maße (mm)
41		14	M5x18
41A		2	M4x18
42		6	M4x8
44A		2	
44B		2	
45A		1	
45B		1	
46		1	
47		162	
48		137	M6
53		44	

## TEILELISTE PC-PANEELE (Karton 2/2)

Nr.	Abbildung	Menge	Maße (mm)
1		11	605 x 1212
2		5	605 x 1130
3A		2	605 x 455
3B		2	605 x 455
4		1	605 x 585

Nr.	Abbildung	Menge	Maße (mm)
5		1	595 x 550
6		1	605 x 675
7		1	605 x 250
8		1	615 x 241
9		2	605 x 602

## HINWEISE ZUR MONTAGE DER PC-PANEELE



Foto der 4 mm PC-Paneele

Die Paneele haben eine weiße Schutzfolienseite ohne UV-Schutz und eine grüne Schutzfolienseite mit UV-Schutz. Die grüne Seite sollte außen sein.

Die Folie schützt die Paneele, deshalb empfehlen wir, die Schutzfolien erst abziehen nachdem die Paneele in den Gewächshausrahmen eingesetzt wurden damit Sie wissen, welche Seite UV-geschützt ist und die Seiten bei der Montage nicht verwechselt werden.

Eine gute Möglichkeit ist es, ca. 5 cm der Schutzfolie von allen Kanten der Platte zu entfernen, bevor Sie die Paneele

in den Alurahmen montieren (damit sie nicht unter die Schrauben und Aluleisten gerät), und wenn die Paneele im Rahmen befestigt ist, können Sie die Schutzfolien vollständig abziehen. Behandeln Sie die Paneele mit besonderer Sorgfalt, damit sie bei der Montage nicht zerkratzt werden.

Wir empfehlen, für die Montage folgendes Werkzeug bereitzuhalten:

- Schutzhandschuhe
- Maßband
- Schlitzschraubenzieher
- Akkuschauber



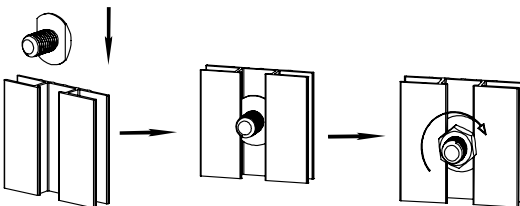

(In der Verpackung ist ein Schraubenschlüssel enthalten.)







So schieben Sie die Schrauben in die Nuten der Aluleisten.

## AUFBAU DACHFENSTER

Bitte legen Sie die Teile wie unten abgebildet hin, setzen Sie die Schrauben (Nr. 40) von oben nach unten ein, montieren Sie zuerst die Teile 28 und 31, dann die Platte (Teil 5) und im nächsten Schritt Teil 30.

Nr.	Abbildung	Menge	Maße (mm)
28		2	520
30		1	595
31		1	595
40		4	M6x10

Nr.	Abbildung	Menge	Maße (mm)
42		2	M4x8
46		1	
48		4	M6
5		1	595 x 550

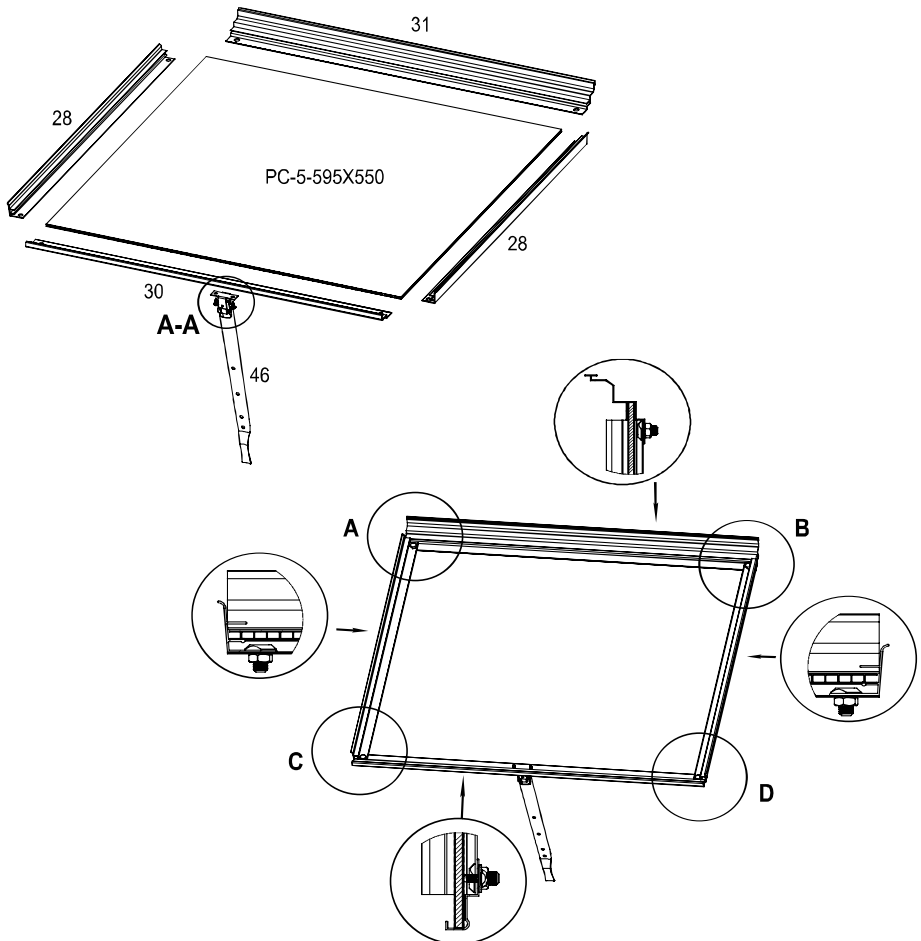

Die grüne Schutzfolienseite mit UV-Schutz, sollte der Sonne zugewandt sein. Die weiße Schutzfolienseite ohne UV-Schutz zum Inneren des Gewächshauses hin.

**AA**

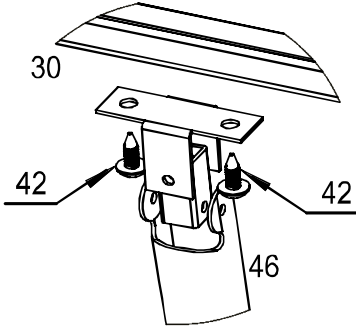

**A**

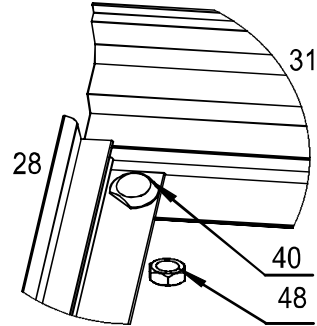

Befestigen Sie die Halterung an den vorgesehenen Schraubenlöchern.

**B**

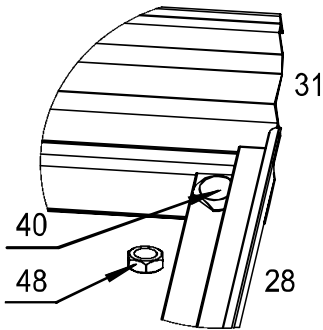

**C**

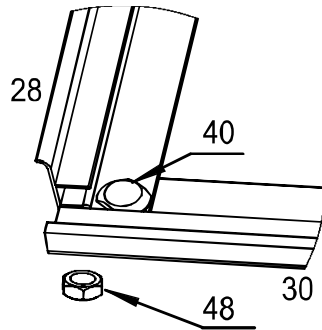





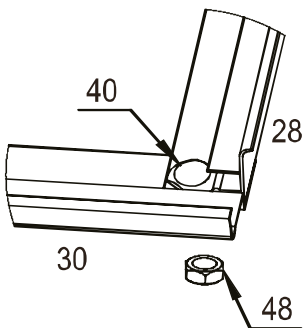

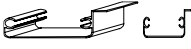

Die Schraube und Mutter erst festziehen nach dem Einsetzen von Teil 30 in die Schraubenposition.

**D**

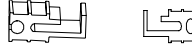

## AUFBAU SCHIEBETÜR-RAHMEN

Nr.	Abbildung	Menge	Maße (mm)
20		2	1608
24		1	610
26		2	610
27		1	610
29		1	608

Nr.	Abbildung	Menge	Maße (mm)
36		2	
40		2	M6x10
41		14	M5x18
41A		2	M4x18
48		2	M4x8

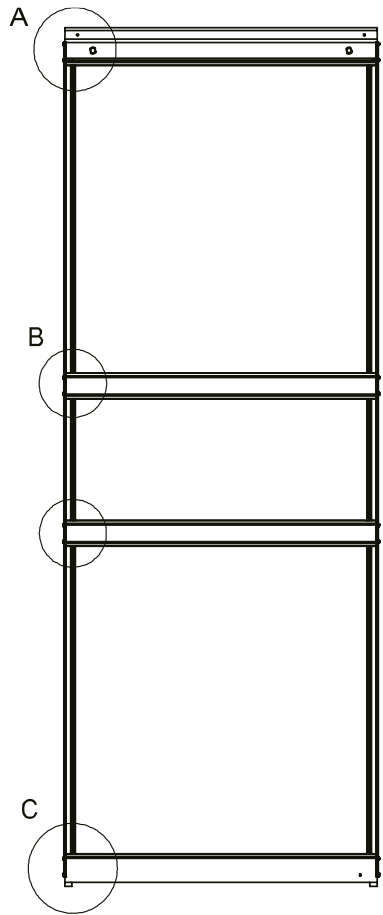
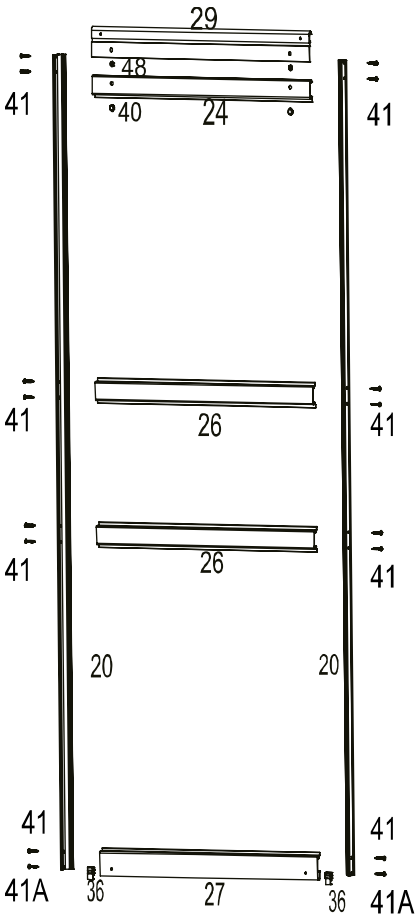

A

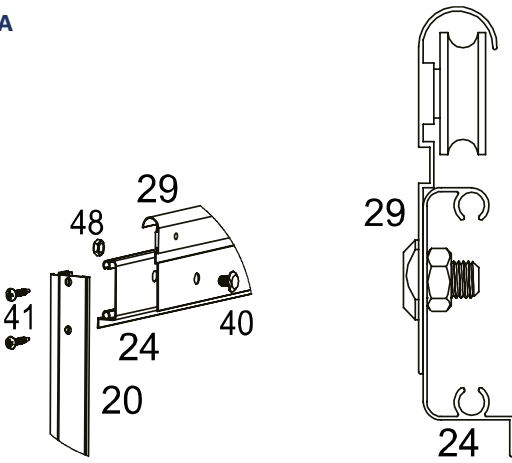

B

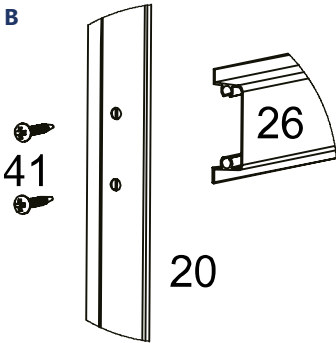

C

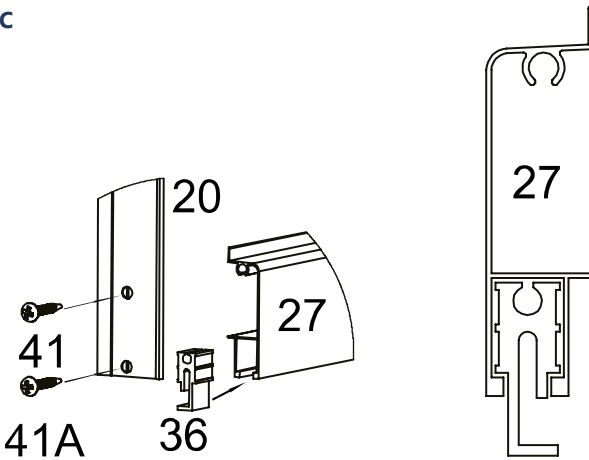

## AUFBAU FRONT-RAHMEN

Nr.	Abbildung	Menge	Maße (mm)
1		2	1215
2		1	1134
3		1	1134
6		1	1647
7		1	1647
12		1	610
13		2	
14		1	1260
17		1	1335
17A		1	467

Nr.	Abbildung	Menge	Maße (mm)
17B		1	170
19		1	380
23		2	594
25		2	1304
37		1	
38		1	
40		26	M6x10
48		27	M6

Bitte beachten Sie bei der Montage die Hinweise zu Teil 2 und Teil 3 beim Zusammenbau. Front-Rahmen vom Inneren des Gewächshauses aus gesehen (Ansichten unten).

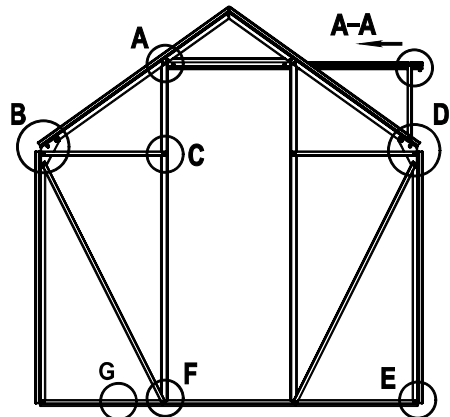
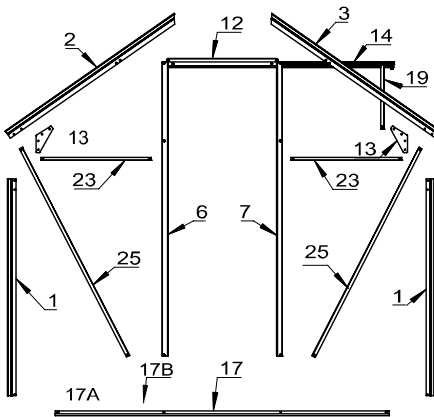

Bildrichtung von der Außenseite des Gewächshauses gesehen.

**AA**



Bild nach der Installation von Teil Nr. 14.

**A**

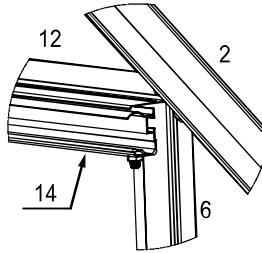
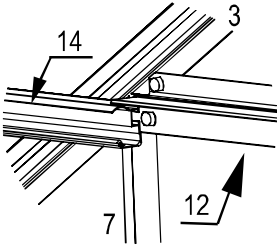
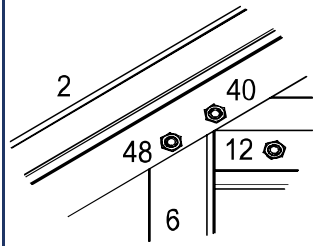

Ausschnitt A zeigt die Innenseite, bitte beachten Sie die Montagerichtungen von Teil 40 und 48.

**B**

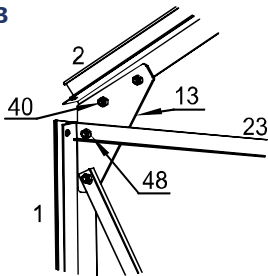

**C**

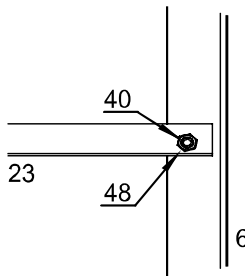

**D**

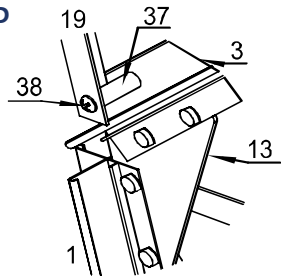

**E**

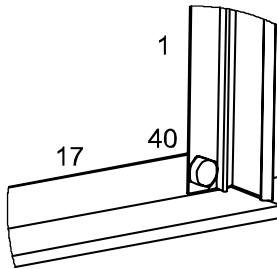

**F**

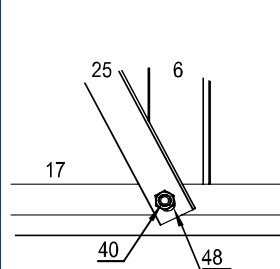

**G**

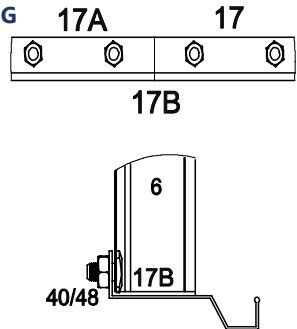

Detailansicht

**AUFBAU LINKE WAND** (von der Tür aus gesehen)

Nr.	Abbildung	Menge	Maße (mm)
10		2	1215
22		2	1304
22A		1	1362
21B		1	
32A		1	1432
32B		1	390
32C		1	170

Nr.	Abbildung	Menge	Maße (mm)
34A		1	1433
34B		1	390
34C		1	170
40		18	M6x10
48		18	M6

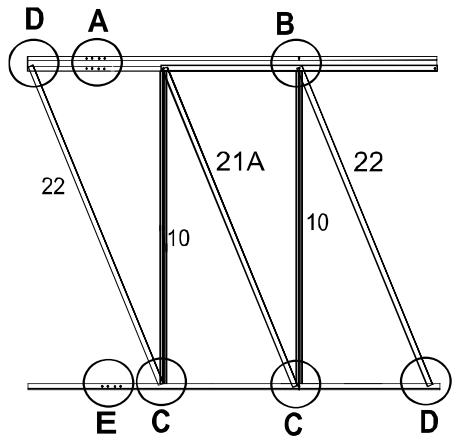
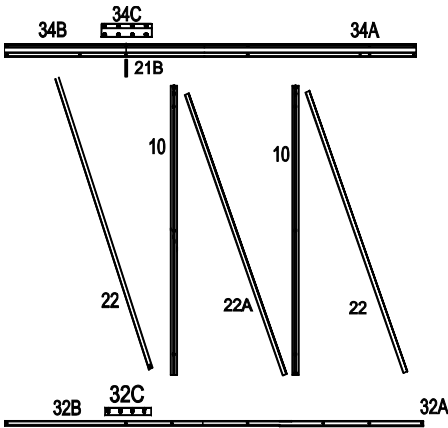

Zuerst Abbildung A und E montieren.

Zwischen 34A/34B den Beschlag 21B in Pfeilrichtung einsetzen und mit 34C mit Schrauben und Muttern sichern.

Bitte ziehen Sie zuerst die Schrauben fest, bevor Sie die Teile 32 und 34 mit den ,Teilen 10, 21A und 22 verbinden.

Seitenwand von innen gesehen.

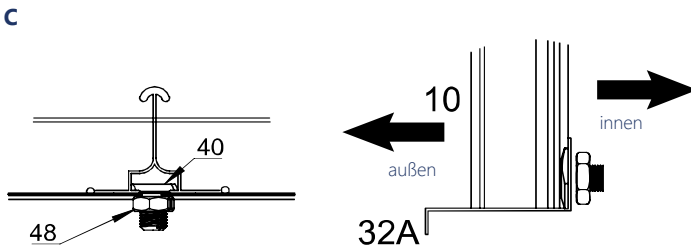
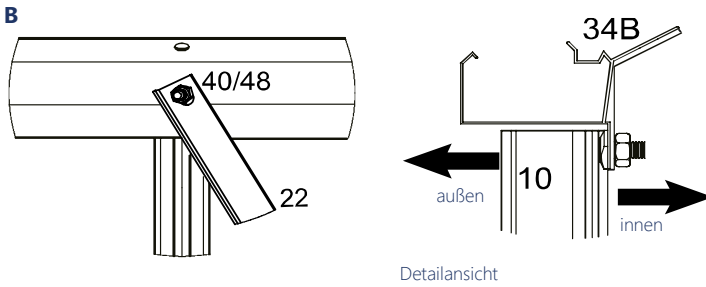
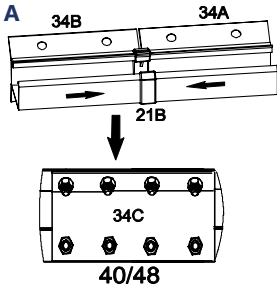

Befestigung von Teil 10 an Teil 32A

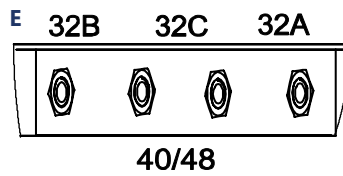
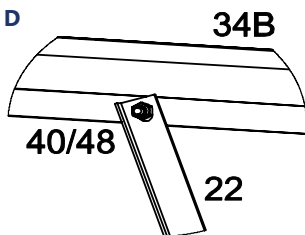

## AUFBAU RECHTE WAND (von der Tür aus gesehen)

Nr.	Abbildung	Menge	Maße (mm)
10		2	1215
22		2	1304
22A		1	1362
21B		1	
32A		1	1432
32B		1	996
32C		1	170

Nr.	Abbildung	Menge	Maße (mm)
34A		1	1433
34B		1	390
34C		1	170
40		18	M6x10
48		18	M6

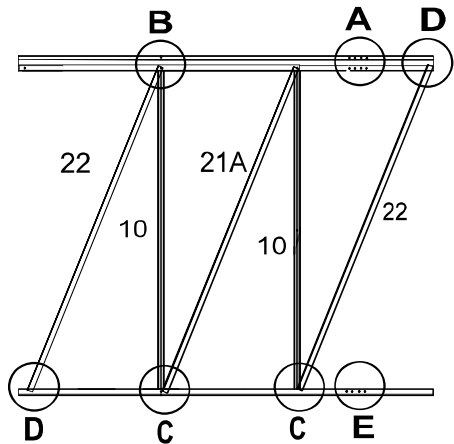
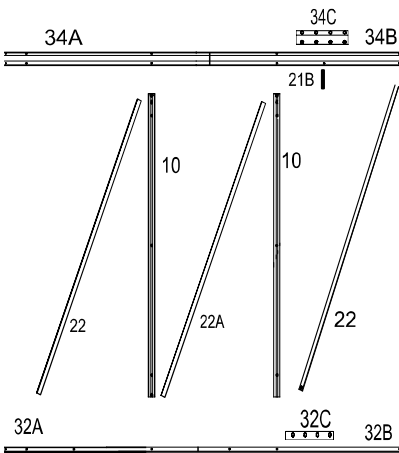

Zuerst Abbildung A und E montieren.

Zwischen 34A/34B den Beschlag 21B in Pfeilrichtung einsetzen und mit 34C mit Schrauben und Muttern sichern.

Bitte ziehen Sie zuerst die Schrauben fest, bevor Sie die Teile 32 und 34 mit den ,Teilen 10, 21A und 22 verbinden.

Seitenwand von innen gesehen.

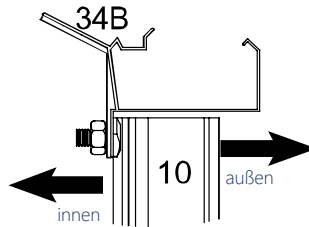
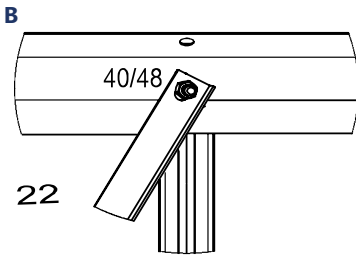
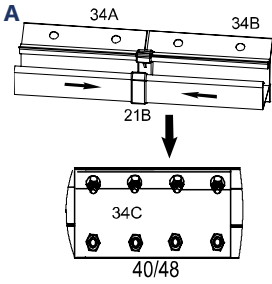

Detailansicht

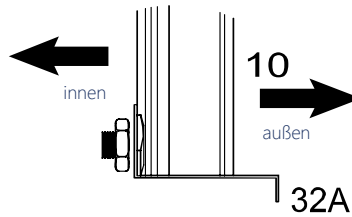
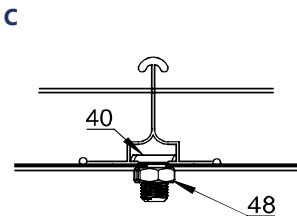

Befestigung von Teil 10 an Teil 32A

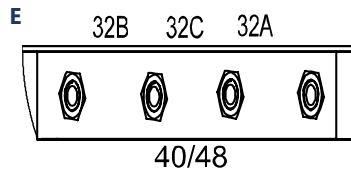
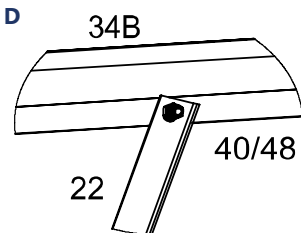

## AUFBAU RÜCKWAND-RAHMEN

Nr.	Abbildung	Menge	Maße (mm)
1		2	1215
4		1	1134
5		1	1134
8		1	1655
9		1	1655
13		2	

Nr.	Abbildung	Menge	Maße (mm)
16		2	911
16A		1	170
21		2	1220
21A		2	610
40		24	M6x10
48		24	M6

Rückwand von innen gesehen

Die Schrauben werden von innen mit Muttern gesichert

Ziehen Sie die Schrauben und Muttern für Ansicht C und E an

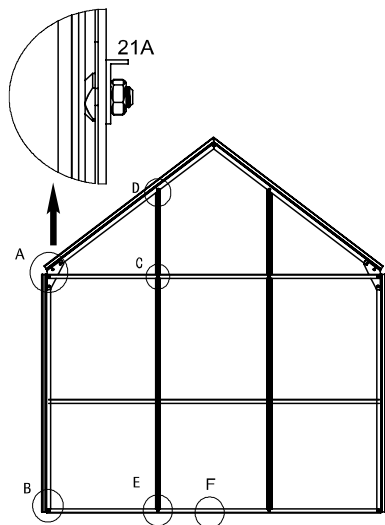
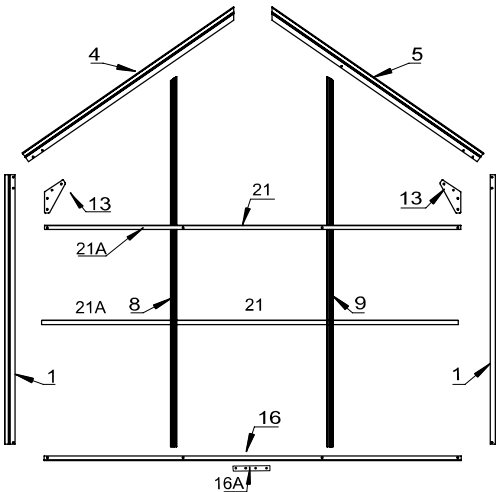

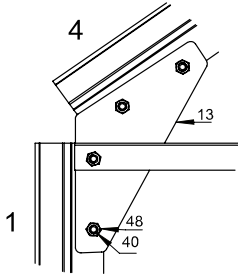
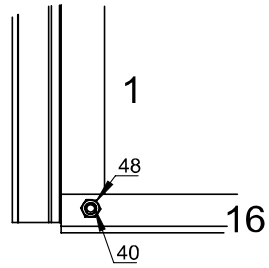
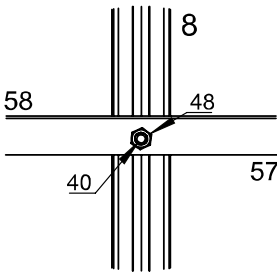
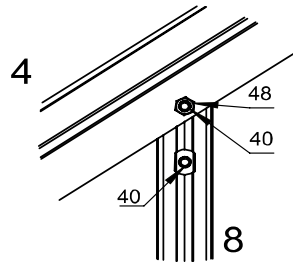
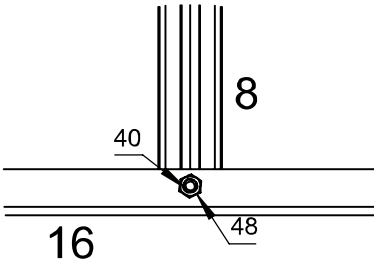
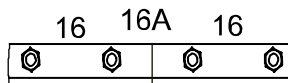
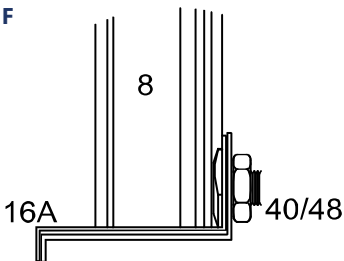
**A****B****C****D****E****F**

Detailansicht

## RAHMEN DER WÄNDE MITEINANDER VERBINDEN

Nr.	Abbildung	Menge	Maße (mm)
33		1	1433
33A		1	388
33C		1	170

Nr.	Abbildung	Menge	Maße (mm)
40		24	M6x10
48		24	M6

Zum Verbinden der Rahmenelemente werden mindestens 2 bis 3 Personen benötigt.

Bitte beachten Sie die untenstehende Anordnung der Aluminiumprofile und die Verwendung von Schrauben zur Befestigung.



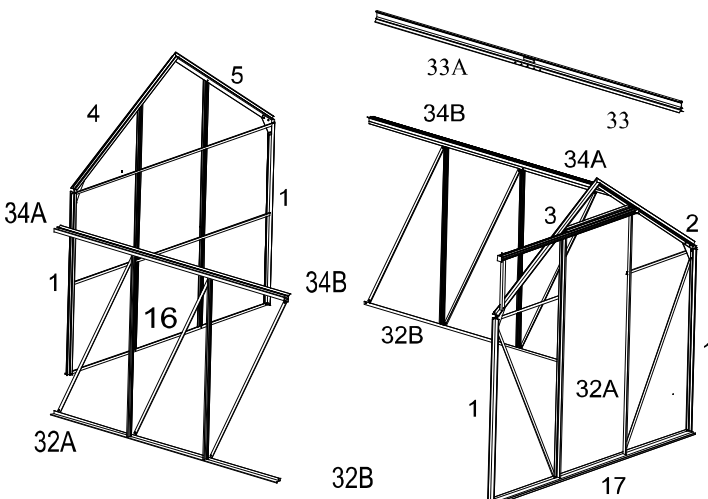
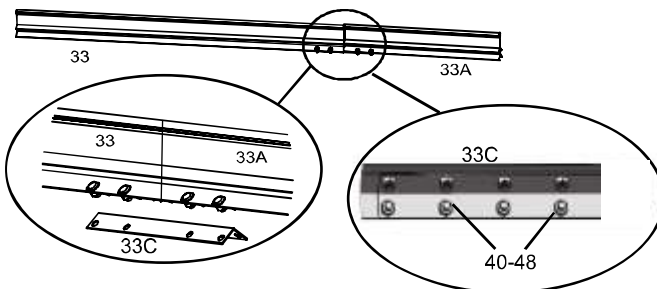

Nachdem Sie die Montage der Wandrahmen beendet haben, bauen Sie den Dachfirst Teil 33 zusammen.

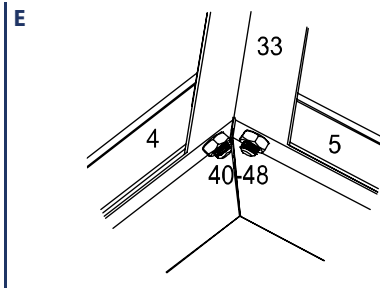
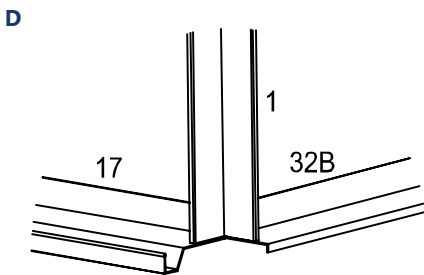
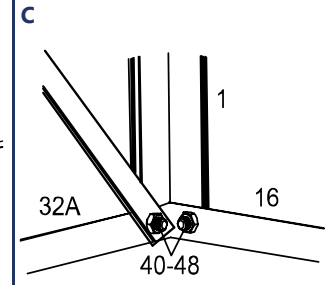
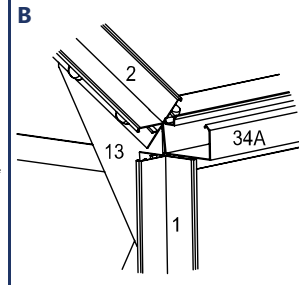
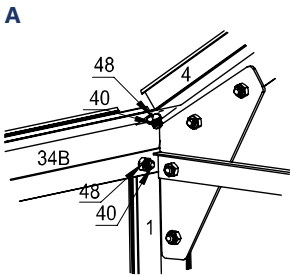
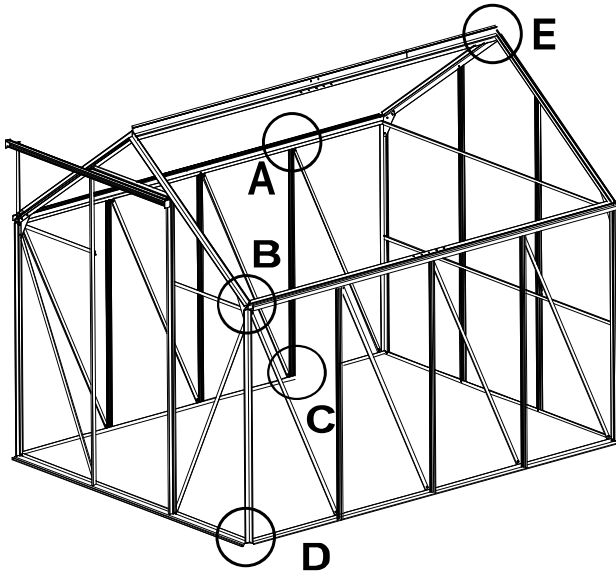

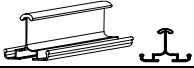
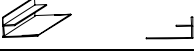

Die endgültige Stabilität des Gewächshauses wird erreicht, nachdem Sie alle Schrauben in den Aluminiumrahmen angezogen und die Paneele montiert haben.

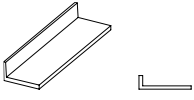



## DACH-RAHMEN MONTIEREN

Nr.	Abbildung	Menge	Maße (mm)
11		4	1114
15		1	634
18		2	
21		2	1220
21A		2	610

Nr.	Abbildung	Menge	Maße (mm)
40		18	M6x10
42		4	M4x18
43		16	
48		18	M6
54		16	

Teil 43 wird benötigt um den Gewächshausboden mit dem Fundament zu verbinden.

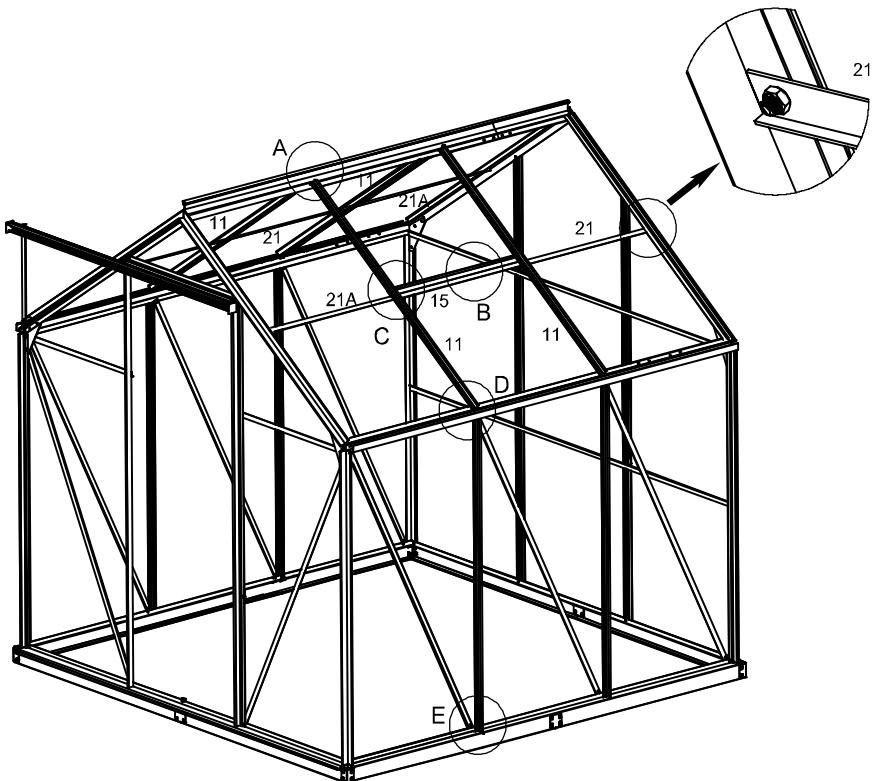

A

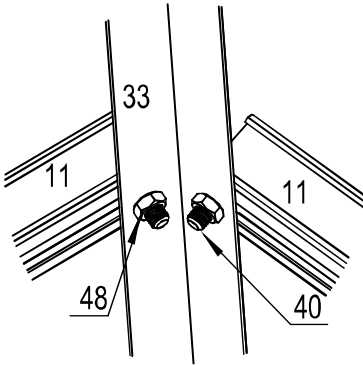

B

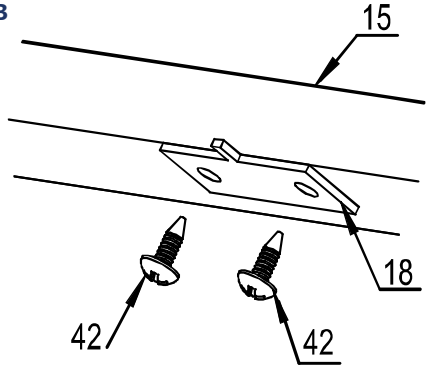

C

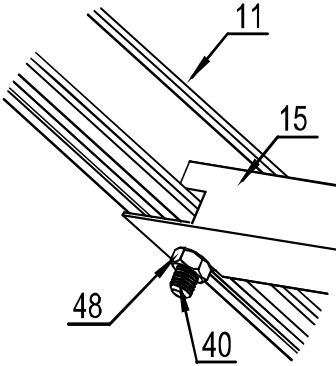



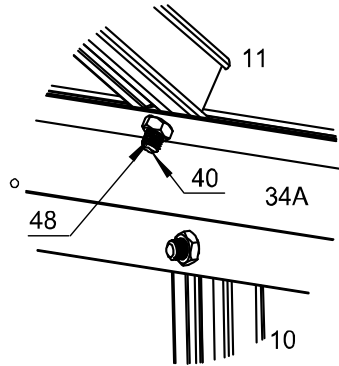

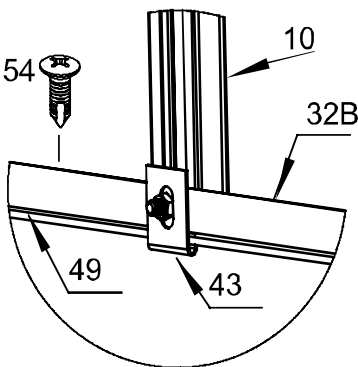

D









E



## ANBRINGEN DER TRANSPARENTEN PC-PANEELE

Nr.	Abbildung	Menge	Maße (mm)
1		11	605 x 1212
2		5	605 x 1130
3A		2	605 x 455
3B		2	605 x 455
4		1	605 x 585
5		1	595 x 550
6		1	605 x 675

Nr.	Abbildung	Menge	Maße (mm)
7		1	605 x 250
8		1	615 x 241
9		2	605 x 602
35		5	
47		162	
53		44	

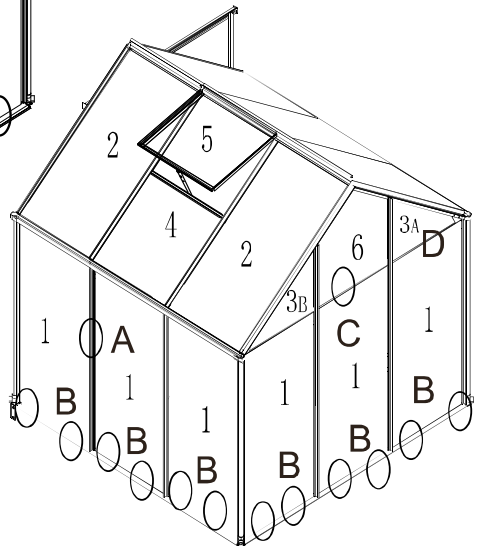
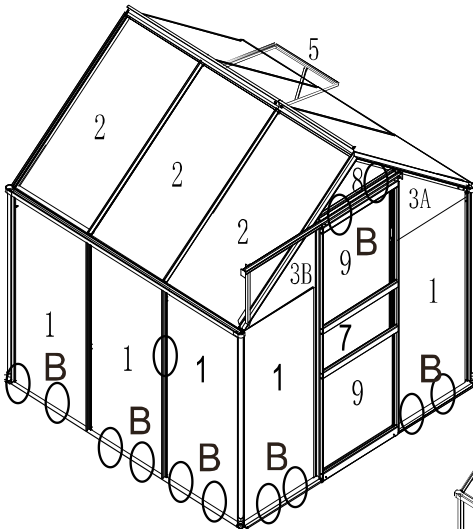

A



B

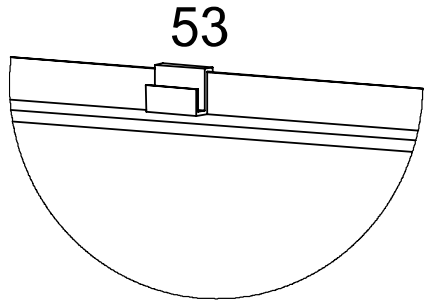

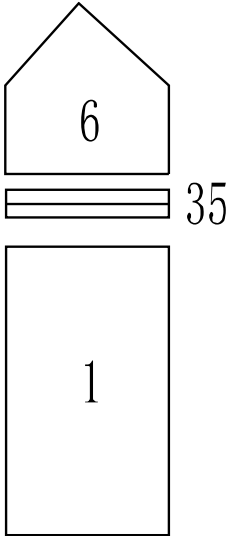

C



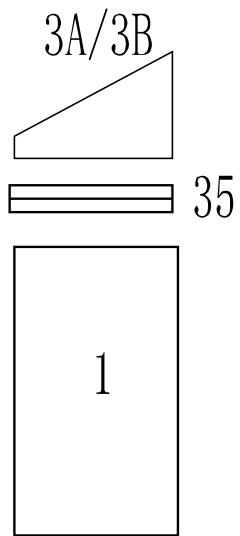

D



## MONTAGE VON SCHIEBETÜR UND REGENRINNE

Nr.	Abbildung	Menge	Maße (mm)
44A		2	
44B		2	
45A		1	

Nr.	Abbildung	Menge	Maße (mm)
45B		1	
40		2	M6x10
48		2	M6

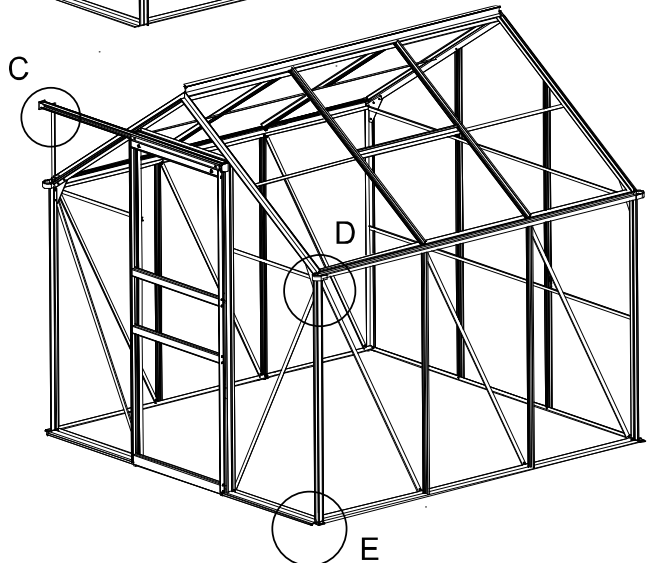
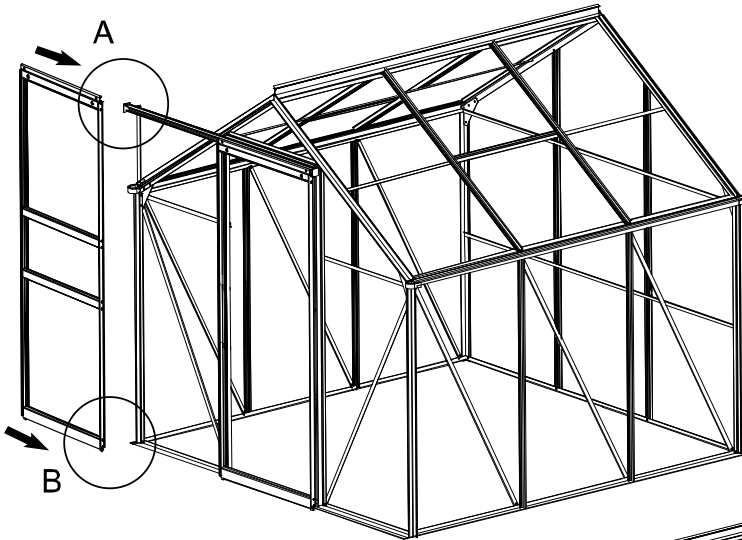

A

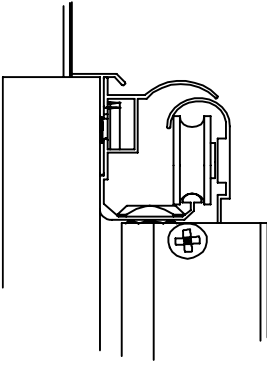

B

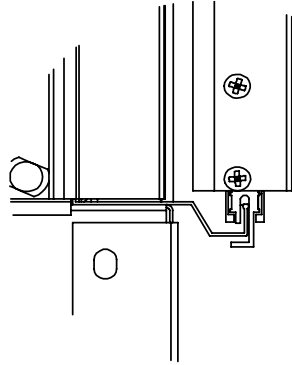

C

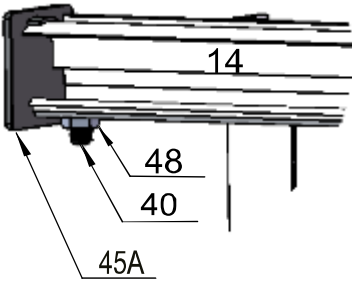

D

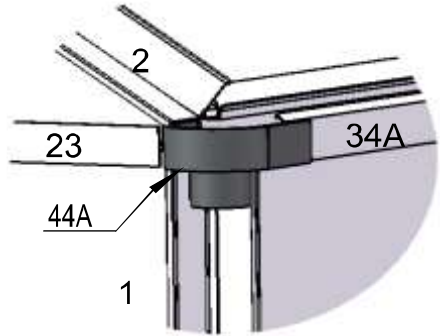

E

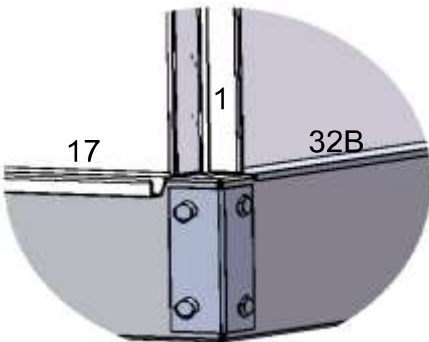

# INSTRUCTIONS

## Dear Customer,

Thank you for choosing our product. You have made the right choice by purchasing one of our branded products. Our products are regularly inspected to ensure that they meet the desired high quality standards and, of course, always comply with the stringent requirements of the European Union.

## TABLE OF CONTENTS

SYMBOLS.....	29
GENERAL NOTES .....	29
INTENDED USE .....	30
UNPACKING INSTRUCTIONS .....	30
CHOOSING A LOCATION .....	30
ASSEMBLY INFORMATION.....	31
MAINTENANCE AND CARE INSTRUCTIONS .....	31
DISPOSAL.....	31
PARTS LIST .....	32
PARTS LIST FOR PC PANEL.....	34
ASSEMBLING THE ROOF WINDOW .....	35
ASSEMBLING THE SLIDING DOOR FRAME.....	37
ASSEMBLING THE FRONT FRAME .....	39
ASSEMBLING THE LEFT WALL .....	41
ASSEMBLING THE RIGHT WALL .....	43
ASSEMBLING THE REAR WALL FRAME .....	45
CONNECTING THE WALL FRAMES TO EACH OTHER .....	47
ASSEMBLING THE ROOF FRAME.....	49
INSTALLING THE TRANSPARENT PC PANELS.....	51
ASSEMBLING THE SLIDING DOOR AND RAIN GUTTER .....	53

## SYMBOLS



### READ THE USER INSTRUCTIONS. IMPORTANT INFORMATION. KEEP IN A SAFE PLACE FOR FUTURE USE!

Read all the instructions carefully and thoroughly before using the product for the first time. Keep this manual for future reference. If you pass on the product one day, be sure to hand over this guide as well.



### WARNING! POTENTIAL DANGER!

Observe the safety information and set-up instructions to avoid the risk of injury or damage to the product.



### DANGER OF SUFFOCATION!

Keep small parts and packaging material out of the reach of children!



### PRODUCT MODIFICATION

Never make modifications to the product! Modifications will invalidate the warranty and the product may become unsafe or, in the worst-case scenario, it may even become dangerous.

## GENERAL NOTES

- We recommend a minimum of 2 people for assembly.

- Choose a location that offers sufficient space around the storage shed to be able to work on it.
- Follow the steps specified in the instructions carefully to ensure correct assembly.
- Check that all parts are present before starting assembly.
- Make sure that the foundation frame lies flat on the ground.
- The foundation must be level. Level the ground if it is uneven.
- Your greenhouse must be firmly anchored to the foundation to prevent damage from strong winds.
- **WARNING!** Do not stand on the roof! Danger of collapse!
- If you use a foundation that is not cast from concrete, make sure that the ground is solid and even. The product must be fastened with a foundation! The greenhouse will only be able to stand permanently and stably if it is precisely aligned. Even if they are slightly crooked, the walls can no longer be properly held in their designated guides and can be slightly lifted out of their hinges by the wind.
- The greenhouse's foundation must be anchored/attached to the floor. The greenhouse's extensive area provides a large contact surface for the wind, which can result in significant injuries and/or property damage.
- Never start a fire in the greenhouse and keep it away from open fires and sparks!
- Do not use this product if parts are missing, damaged, or worn out.
- Make sure that you do not lock any people and/or animals in the greenhouse!
- Avoid overhanging trees wherever possible, as falling leaves require regular clearance and breaking branches are a potential source of danger.
- Small trees, bushes or fences nearby can be helpful as windbreaks.
- **WARNING!** Close the doors and windows during wind and storms.

### **INTENDED USE**

The greenhouse is designed for planting and breeding vegetables, flowers and other plants. The storage shed is not suitable for the storage of hazardous materials or for the accommodation of people or animals. Use the product only for the purpose it is intended for. The manufacturer accepts no liability for damage caused by improper use. Any modification to the product may negatively impact safety, cause hazards and invalidate the warranty.

**Only suitable for domestic use; not for commercial use.**

### **UNPACKING INSTRUCTIONS**

Open the box and remove all parts and elements in the set. Place the components on the top of the box or other clean surface. This will protect your new product. After unpacking, please check the product for damage and to ensure it is complete. Subsequent complaints cannot be accepted.

### **CHOOSING A LOCATION**

Before you start assembly, familiarise yourself with relevant local rules and regulations. When choosing the most suitable location for the greenhouse, ensure that the ground is solid and level and do not choose a site where the shed would be completely exposed to the elements! You must ensure some level of protection against storms and turbulent gusts. Without this, damage may occur.

## ASSEMBLY INFORMATION

Follow the diagrams illustrating the construction steps.



When assembling, always wear safety gloves, long sleeves and protective goggles. Some parts may have sharp edges that could cause injury!

Scan the corresponding QR code to go directly to the assembly video.

- Before setting up the greenhouse, a suitable foundation must be set up accordingly. You can obtain these kinds of foundations (auxiliary formworks) from us at the online shop.
- Do not set up the greenhouse in wind or in wet conditions.
- Remove the parts from the carton and sort them according to the numbers. Make sure that all the parts required for assembly are present.
- Familiarize yourself with the functionality of all the tools.
- Keep children and pets away from the installation site.
- If you use a ladder, make sure it is properly positioned. Please do not place your full weight on any part of the roof or greenhouse.
- Some assembly steps require two people.
- Store small parts (screws, etc.) in the cartons and bags to avoid losing them.
- Each part is numbered, and you can find the corresponding number in the assembly instructions.
- Start the assembly by arranging the parts with the same number in their own groups around the setup area.
- The greenhouse's aluminium frame is first set up and the PC panels are inserted last.

## MAINTENANCE AND CARE INSTRUCTIONS

- Use a sponge and warm soapy water for cleaning. Do not use cleaners or detergents containing solvents; substances such as bleach can damage the product.
- Always use the appropriate tool when performing any work on the greenhouse.
- Immediately replace damaged individual parts of the greenhouse! People and animals can be injured by damaged parts!
- Ensure that you keep the roof as free of snow as possible during winter. It can collapse under an excess amount of snow. More than 10 cm of snow can already pose a hazard (layer thicknesses of 36 cm of dry snow, 10 cm of wet snow, and 5.5 cm of ice are equivalent to a weight of approx. 50 kg/m<sup>2</sup>).
- Please contact our service team in case of unforeseen problems. We are happy to assist you.













## DISPOSAL



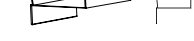



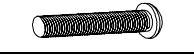
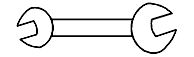



At the end of your product's long service life, please dispose of the valuable raw materials appropriately so that proper recycling can take place. If you are not sure how best to proceed, local waste disposal companies or recycling centres will be happy to help.

**PARTS LIST** (carton 1/2)





No.	Figure	Quantity	Dimensions (mm)
1		4	1215
2		1	1134
3		1	1134
4		1	1134
5		1	1134
6		1	1647
7		1	1647
8		1	1655
9		1	1655
10		4	1215
11		4	1114
12		1	610
13		4	
14		1	1260
15		1	634
16		2	911
16A		1	170
17		1	1355
17A		1	467
17B		1	170





No.	Figure	Quantity	Dimensions (mm)
18		2	
19		1	380
20		2	1608
21		4	1220
21A		4	610
21B		2	
22		4	1350
22A		2	1362
23		2	594
24		1	610
25		2	1304
26		2	610
27		1	610
28		2	520
29		1	608
30		1	595
31		1	595
32A		2	1432
32B		2	390
32C		2	170

No.	Figure	Quantity	Dimensions (mm)
33		1	1433
33A		1	388
33C		1	170
34A		2	1433
34B		2	390
34C		2	170
35		5	603
36		2	
37		1	
38		1	M5x30
39		2	
40		138	M6x10

No.	Figure	Quantity	Dimensions (mm)
41		14	M5x18
41A		2	M4x18
42		6	M4x8
44A		2	
44B		2	
45A		1	
45B		1	
46		1	
47		162	
48		137	M6
53		44	

## PARTS LIST FOR PC PANEL (carton 2/2)

No.	Figure	Quantity	Dimensions (mm)
1		11	605 x 1212
2		5	605 x 1130
3A		2	605 x 455
3B		2	605 x 455
4		1	605 x 585

No.	Figure	Quantity	Dimensions (mm)
5		1	595 x 550
6		1	605 x 675
7		1	605 x 250
8		1	615 x 241
9		2	605 x 602

## INFORMATION ON ASSEMBLING THE PC PANELS



Photo of 4 mm PC panel

Panels have a white protective film side without UV protection and a green protective film side with UV protection. The green side should be on the outside.

The film protects the panels, which is why we recommend removing the protective films only after the panels have been inserted into the greenhouse frame so that you know which side is UV-protected and to avoid mixing up the sides during assembly.

We recommend removing approx. 5 cm of the protective film from all the corners of the panel before you install the panels in the aluminium frame (to prevent them from getting under the screws and aluminium bars) and once the panels are fastened into the frame, you may fully remove the plastic films. Treat the panels with exceptional care to avoid scratching them during assembly.

We recommend having the following tools ready for assembly:

- Protective gloves
- Measuring tape
- Slotted screwdriver
- Cordless screwdriver



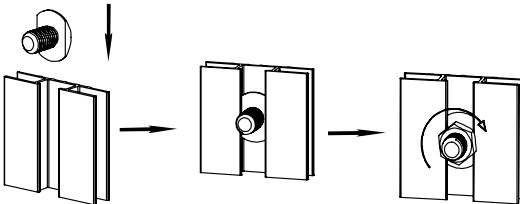

(A spanner is included in the package.)







How to screw the screws into the grooves of the aluminium bars.

## ASSEMBLING THE ROOF WINDOW

Please set down the parts as illustrated below, insert the screws (no. 40) from top to bottom, first install parts 28 and 31, then the panel (part 5) and afterwards part 30.

No.	Figure	Quantity	Dimensions (mm)
28		2	520
30		1	595
31		1	595
40		4	M6x10

No.	Figure	Quantity	Dimensions (mm)
42		2	M4x8
46		1	
48		4	M6
5		1	595 x 550

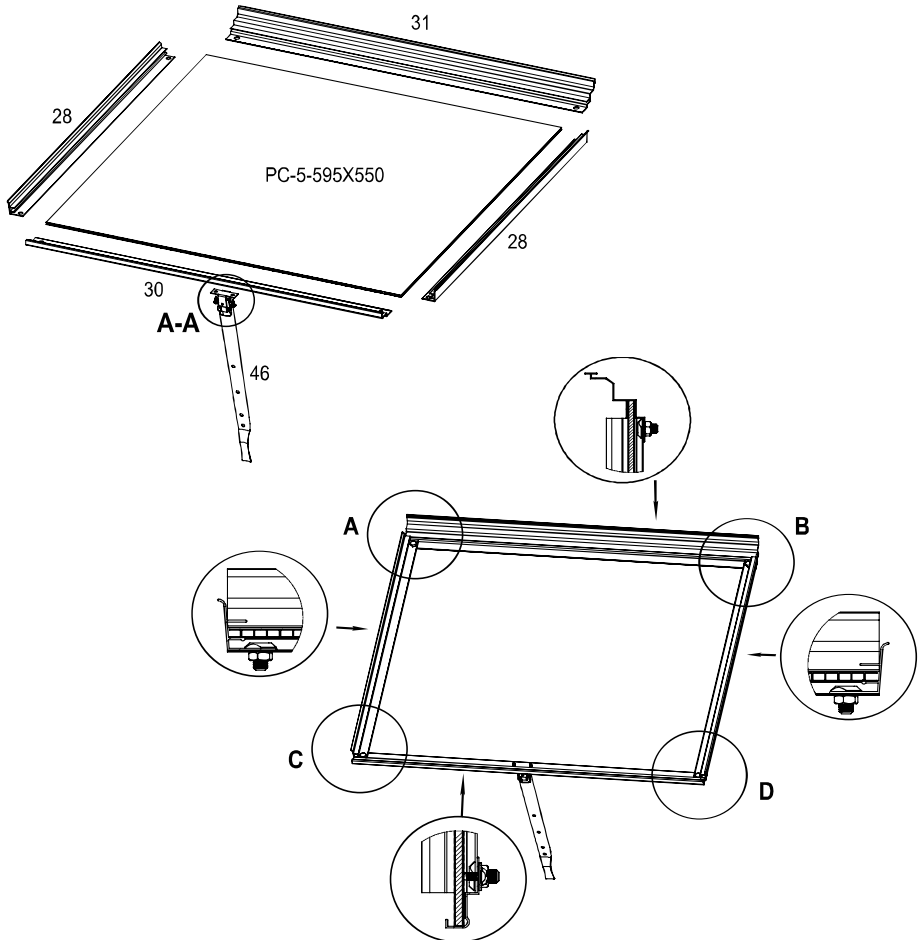

The green protective film side with UV protection should be facing the sun. The white protective film side without UV protection should be facing the inside of the greenhouse.

**AA**

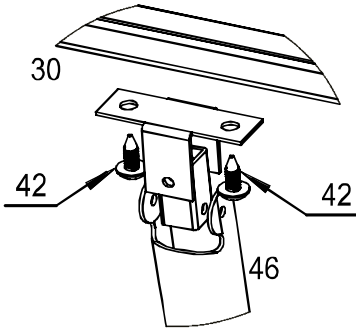

**A**

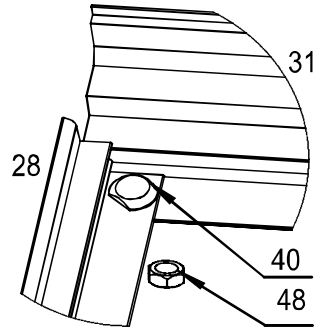

Fasten the bracket to the designated screw holes.

---

**B**

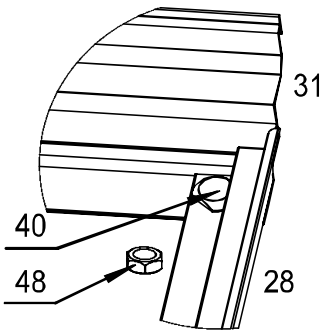

**C**

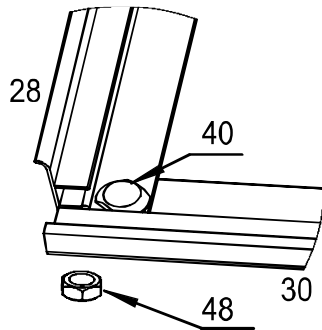



First tighten the screw and nut after inserting part 30 into the screw position.



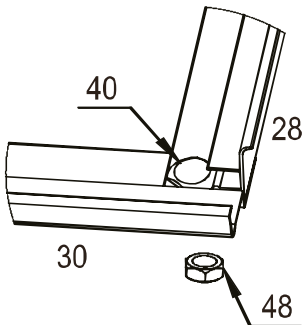

---

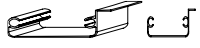
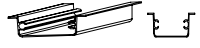
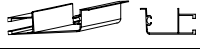
**D**

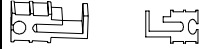

### ASSEMBLING THE SLIDING DOOR FRAME

No.	Figure	Quantity	Dimensions (mm)
20		2	1608
24		1	610
26		2	610
27		1	610
29		1	608

No.	Figure	Quantity	Dimensions (mm)
36		2	
40		2	M6x10
41		14	M5x18
41A		2	M4x18
48		2	M4x8

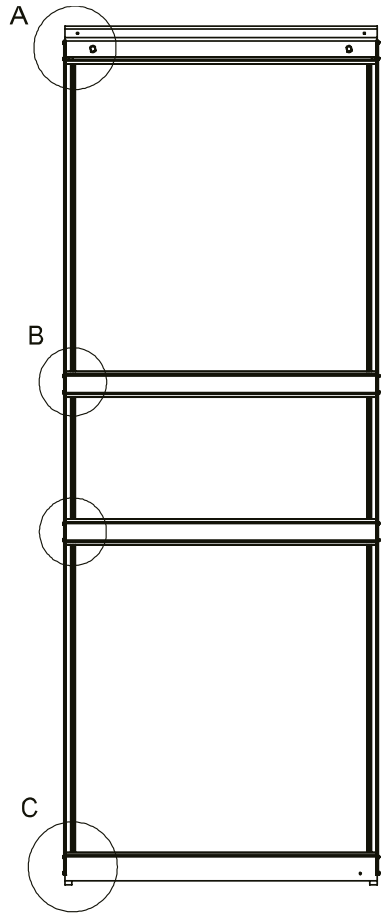
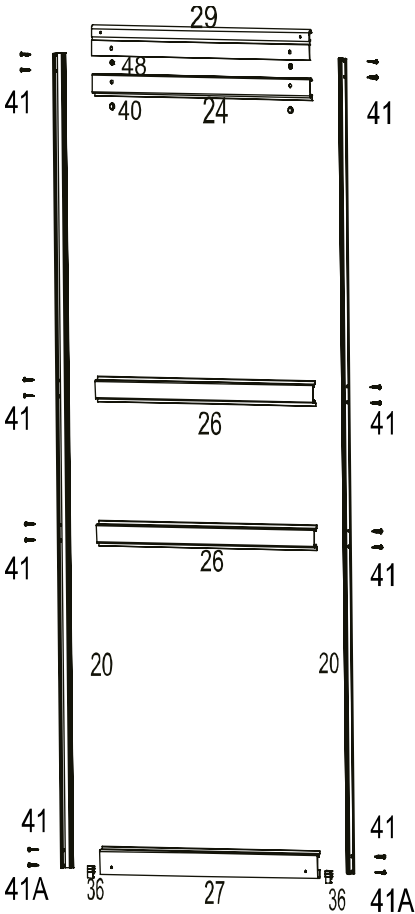

A

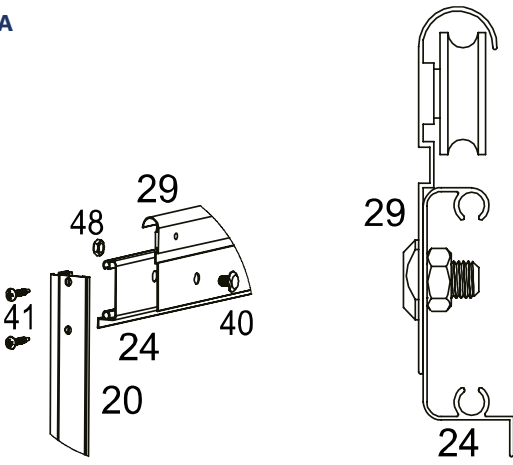

B

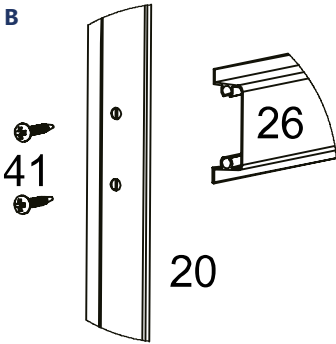

C

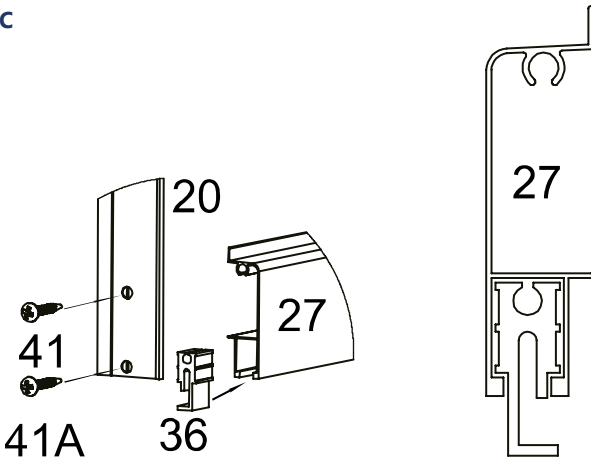

## ASSEMBLING THE FRONT FRAME

No.	Figure	Quantity	Dimensions (mm)
1		2	1215
2		1	1134
3		1	1134
6		1	1647
7		1	1647
12		1	610
13		2	
14		1	1260
17		1	1335
17A		1	467

No.	Figure	Quantity	Dimensions (mm)
17B		1	170
19		1	380
23		2	594
25		2	1304
37		1	
38		1	
40		26	M6x10
48		27	M6

During assembly, please follow the instructions regarding part 2 and part 3.  
Front frame as seen from the inside of the greenhouse (bottom view).

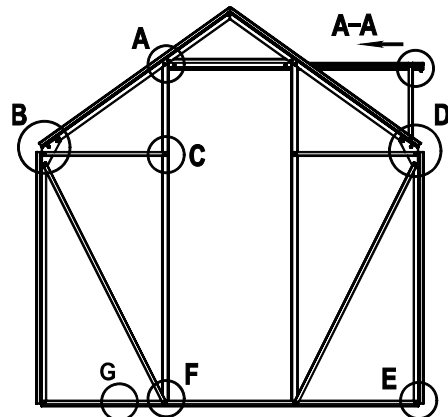
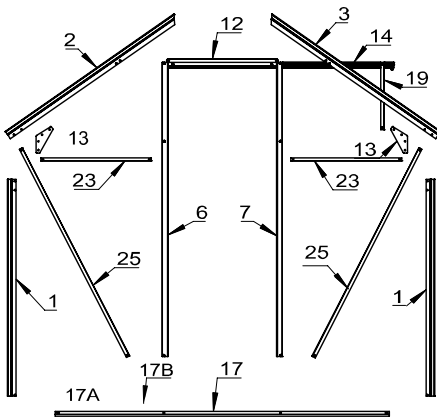

Image alignment seen from the outside of the greenhouse.

**AA**

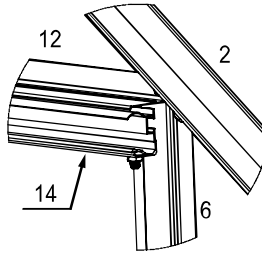
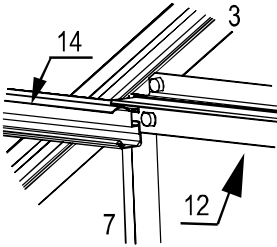
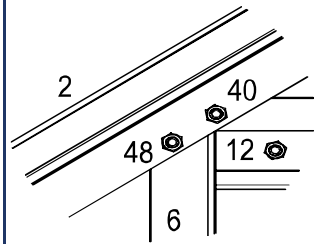

Image after installation of Part no. 14.

**A**



Section A shows the inside; please follow the installation directions of part 40 and 48.

**B**

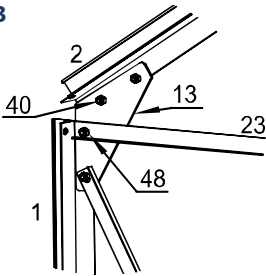

**C**

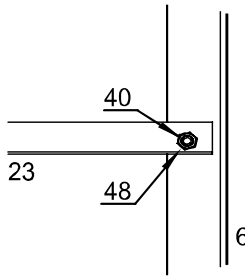

**D**

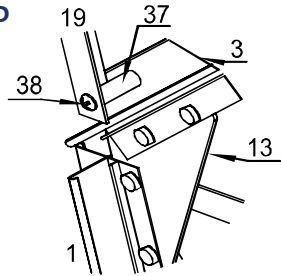

**E**

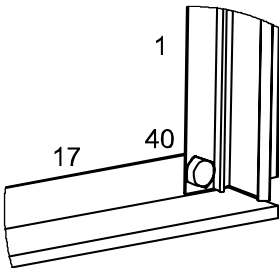

**F**

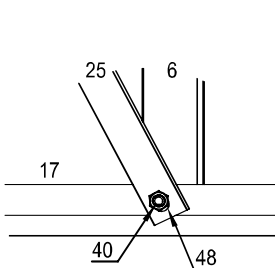

**G**

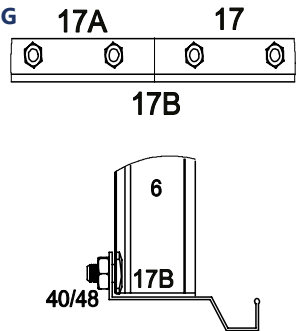

Detailed view

**ASSEMBLING THE LEFT WALL (seen from the door)**

No.	Figure	Quantity	Dimensions (mm)
10		2	1215
22		2	1304
22A		1	1362
21B		1	
32A		1	1432
32B		1	390
32C		1	170

No.	Figure	Quantity	Dimensions (mm)
34A		1	1433
34B		1	390
34C		1	170
40		18	M6x10
48		18	M6

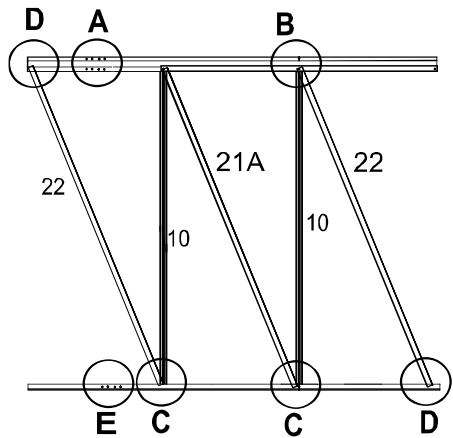
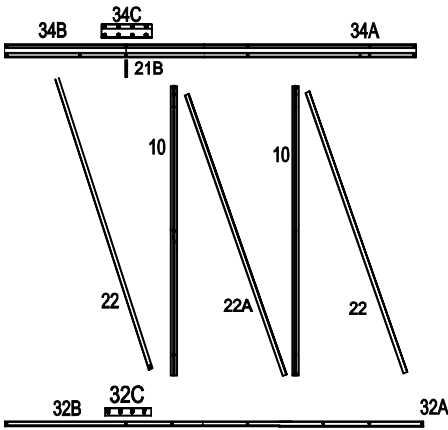

First assemble figures A and E.

Insert fitting 21B between 34A/34B in the direction of the arrow and secure with 34C using screws and nuts.

Please tighten the screws first before you connect parts 32 and 34 to parts 10, 21A, and 22.

Side wall seen from the inside.

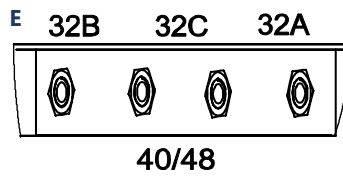
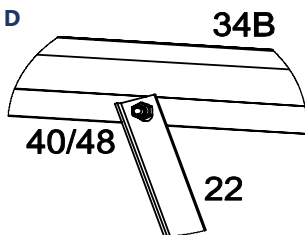
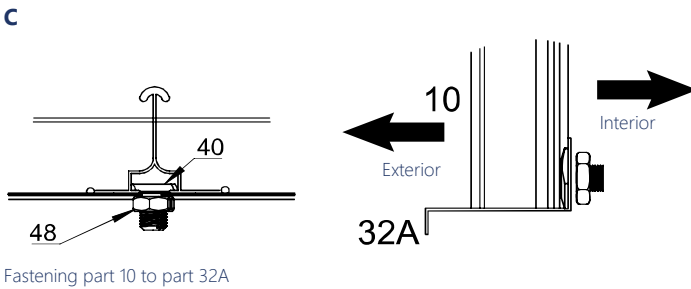
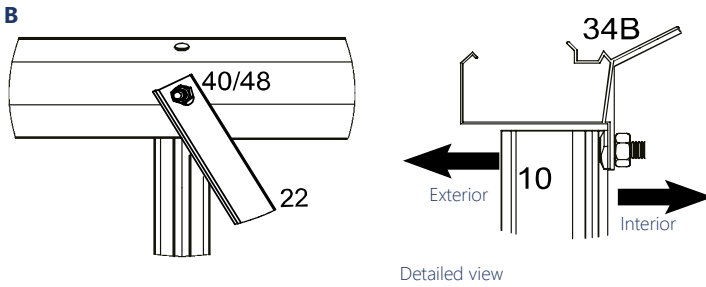
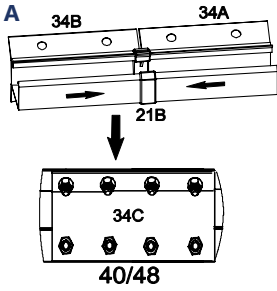

**ASSEMBLING THE RIGHT WALL** (seen from the door)

No.	Figure	Quantity	Dimensions (mm)
10		2	1215
22		2	1304
22A		1	1362
21B		1	
32A		1	1432
32B		1	996
32C		1	170

No.	Figure	Quantity	Dimensions (mm)
34A		1	1433
34B		1	390
34C		1	170
40		18	M6x10
48		18	M6

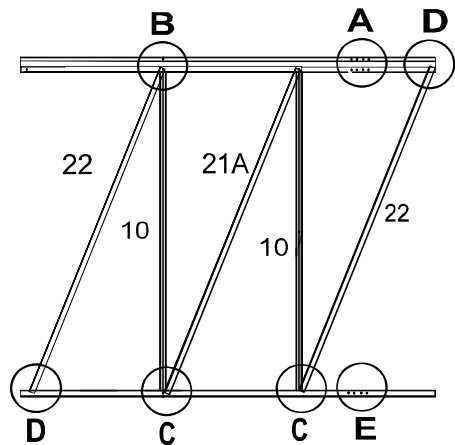
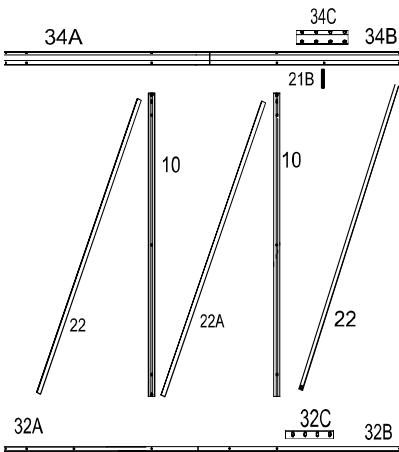

First assemble figures A and E.

Insert fitting 21B between 34A/34B in the direction of the arrow and secure with 34C using screws and nuts.

Please tighten the screws first before you connect parts 32 and 34 to parts 10, 21A, and 22.

Side wall seen from the inside.

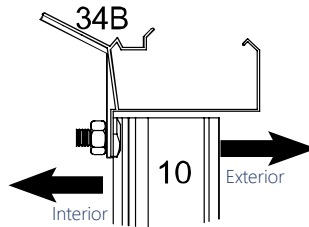
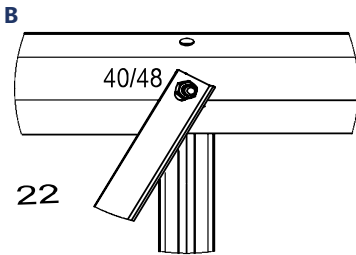
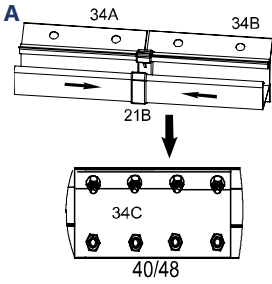

Detailed view

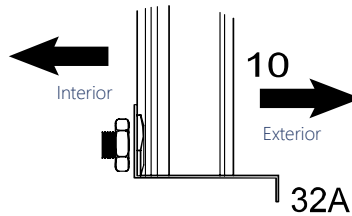
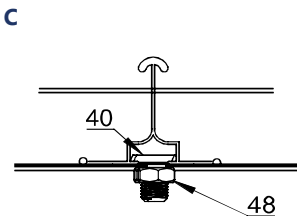

Fastening part 10 to part 32A

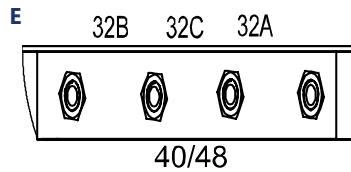
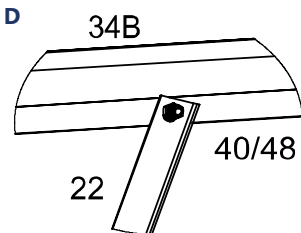

## ASSEMBLING THE REAR WALL FRAME

No.	Figure	Quantity	Dimensions (mm)
1		2	1215
4		1	1134
5		1	1134
8		1	1655
9		1	1655
13		2	

No.	Figure	Quantity	Dimensions (mm)
16		2	911
16A		1	170
21		2	1220
21A		2	610
40		24	M6x10
48		24	M6

Rear wall seen from the inside

The screws are secured from the inside using nuts

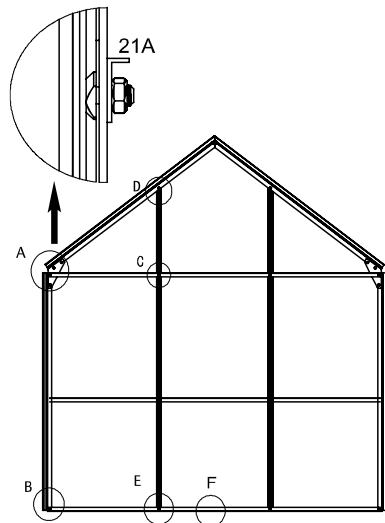
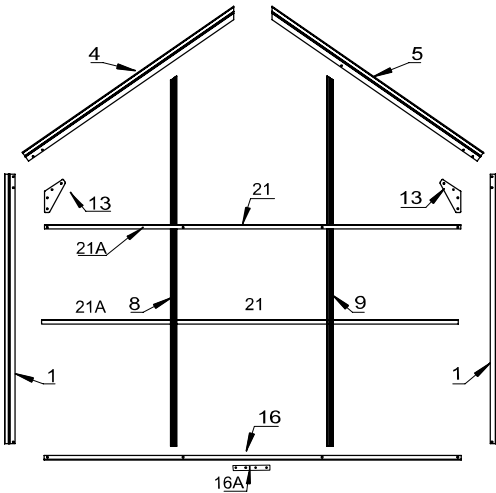

Tighten the screws and nuts for view C and E

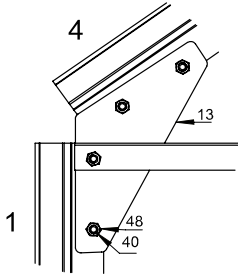
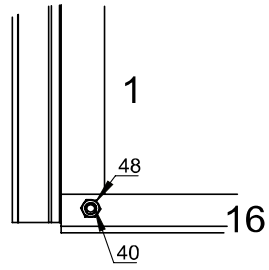
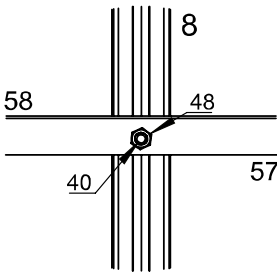
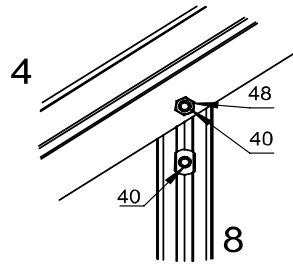
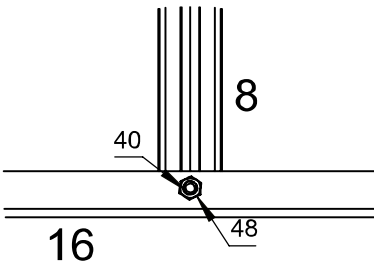
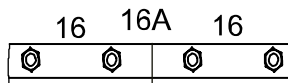
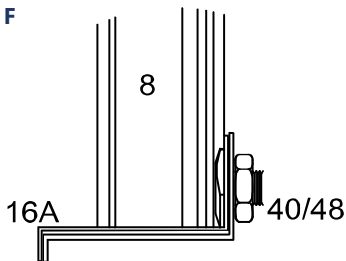

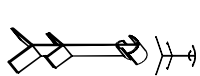
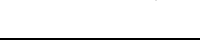

**A****B****C****D****E****F**

Detailed view

## CONNECTING THE WALL FRAMES TO EACH OTHER

No.	Figure	Quantity	Dimensions (mm)
33		1	1433
33A		1	388
33C		1	170

No.	Figure	Quantity	Dimensions (mm)
40		24	M6x10
48		24	M6

At least 2 to 3 people are required to connect the frame elements.

Please observe the aluminium profile arrangement below and use screws for fastening.



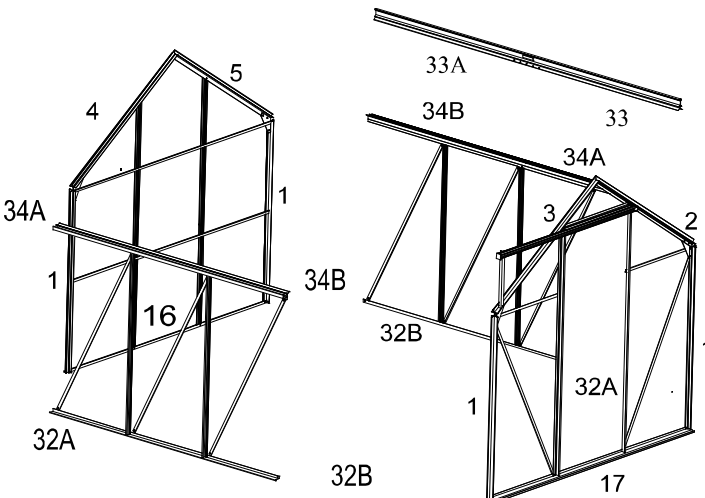
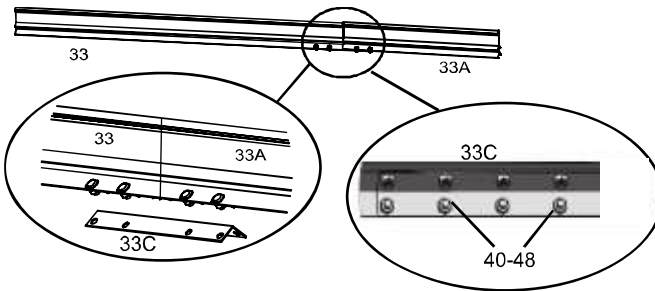

After you have finished installing the wall frame, assemble roof ridge part 33.

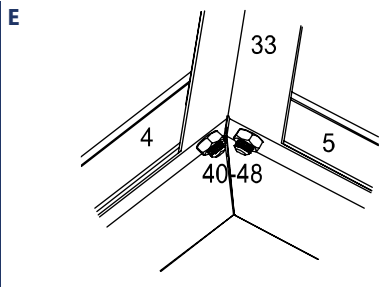
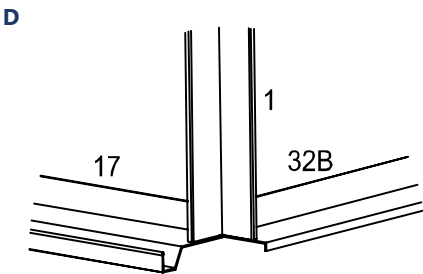
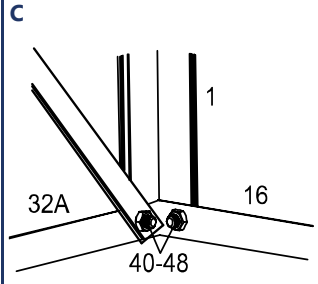
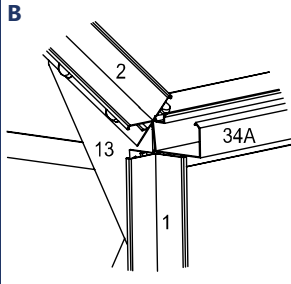
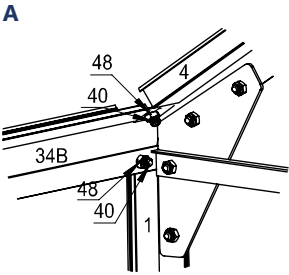
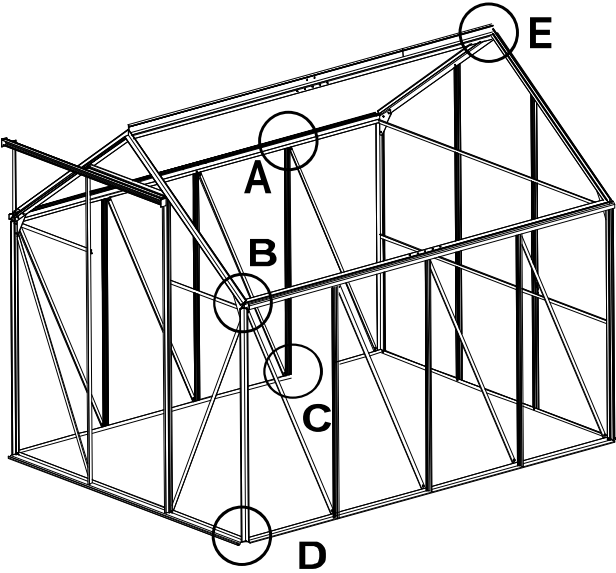

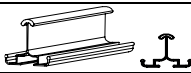
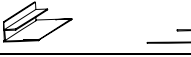

The greenhouse will ultimately be stable once you have tightened all the screws in the aluminium frame and have installed the panels.





## ASSEMBLING THE ROOF FRAME

No.	Figure	Quantity	Dimensions (mm)
11		4	1114
15		1	634
18		2	
21		2	1220
21A		2	610





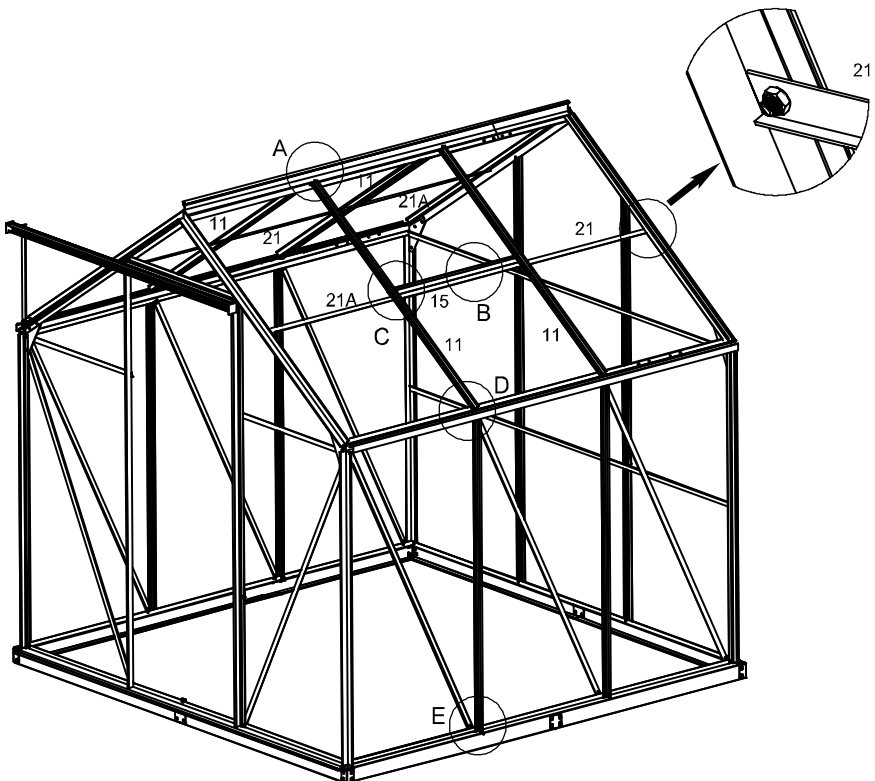

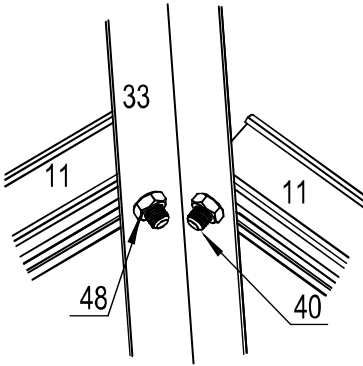
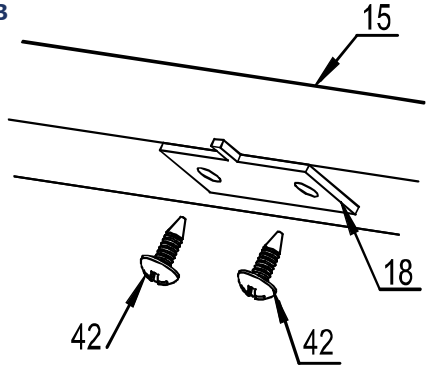
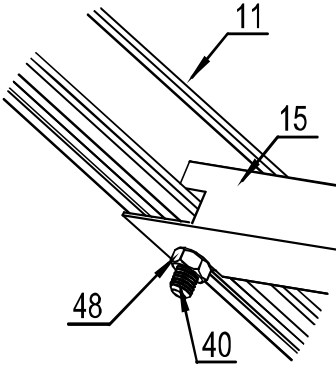
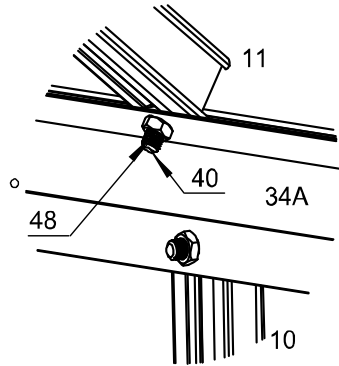
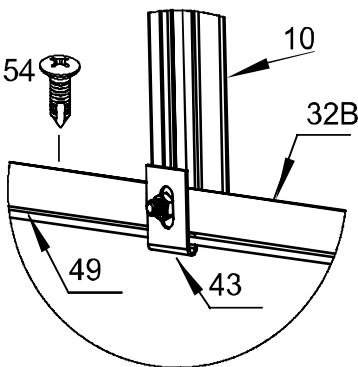
No.	Figure	Quantity	Dimensions (mm)
40		18	M6x10
42		4	M4x18
43		16	
48		18	M6
54		16	







Part 43 is required to connect the greenhouse floor to the foundation.



**A****B****C****D****E**

## INSTALLING THE TRANSPARENT PC PANELS

No.	Figure	Quantity	Dimensions (mm)
1		11	605 x 1212
2		5	605 x 1130
3A		2	605 x 455
3B		2	605 x 455
4		1	605 x 585
5		1	595 x 550
6		1	605 x 675

No.	Figure	Quantity	Dimensions (mm)
7		1	605 x 250
8		1	615 x 241
9		2	605 x 602
35		5	
47		162	
53		44	

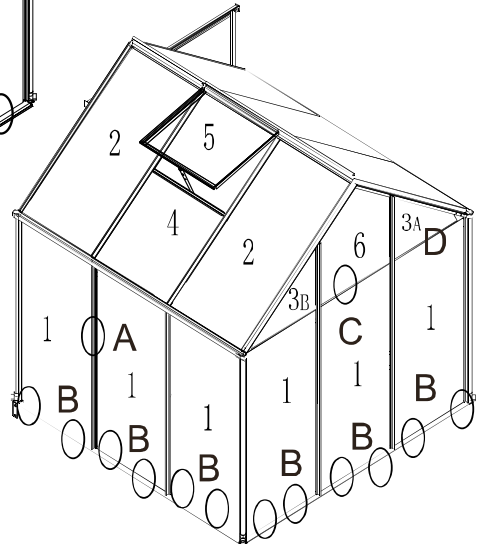
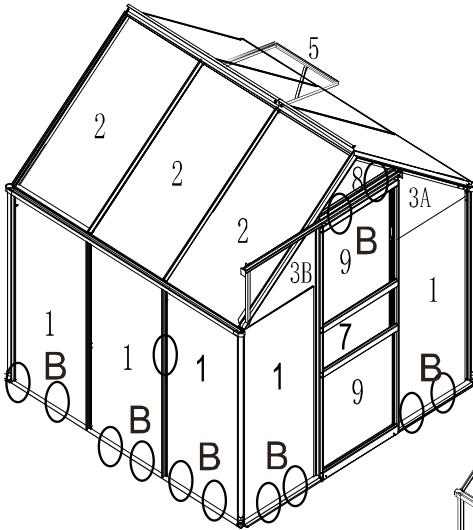

A



B

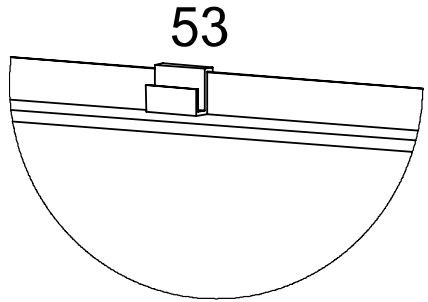

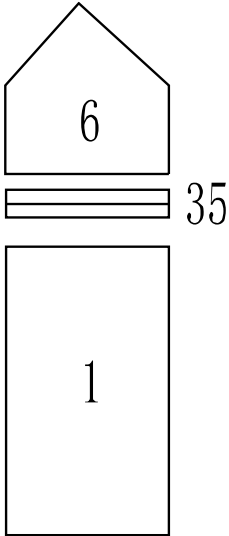

C



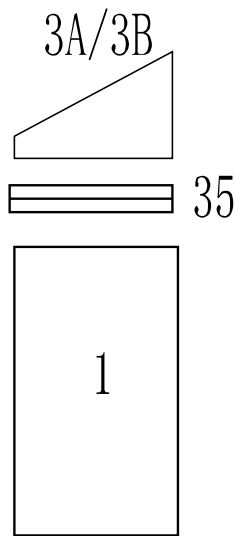

D



## ASSEMBLING THE SLIDING DOOR AND RAIN GUTTER

No.	Figure	Quantity	Dimensions (mm)
44A		2	
44B		2	
45A		1	

No.	Figure	Quantity	Dimensions (mm)
45B		1	
40		2	M6x10
48		2	M6

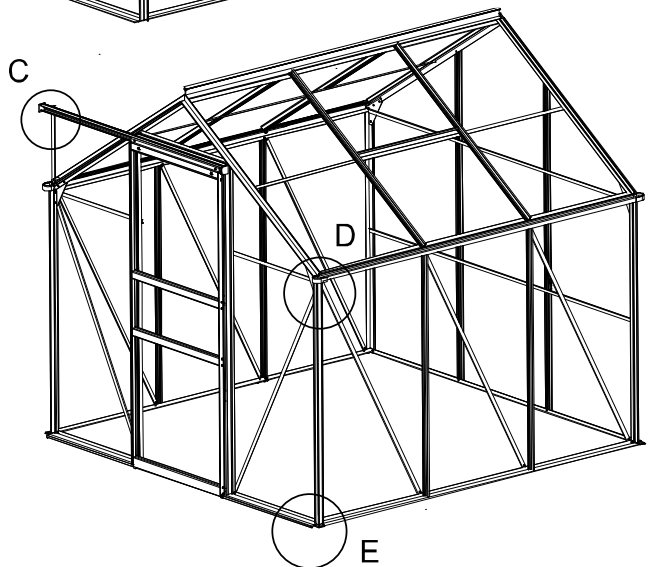
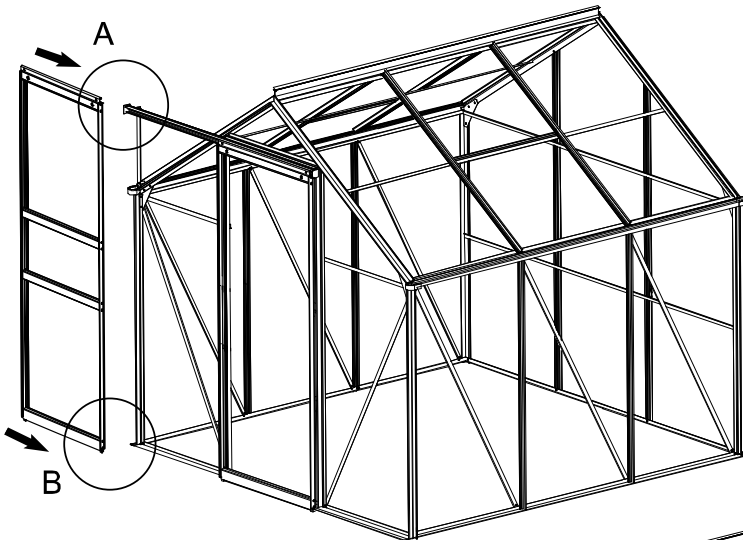

A

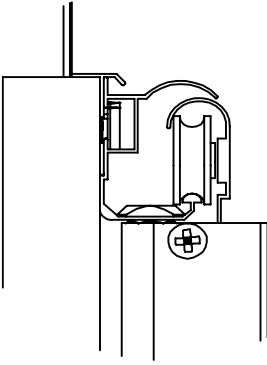

B

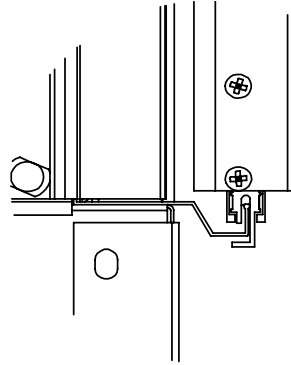

C

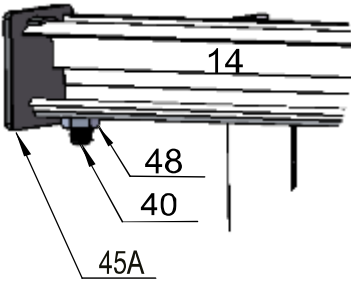

D

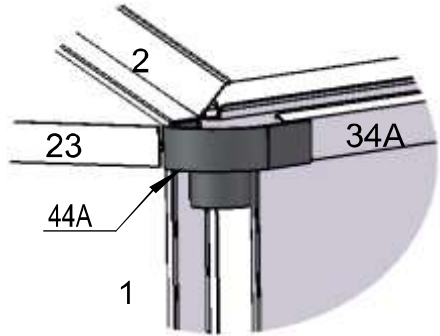

E

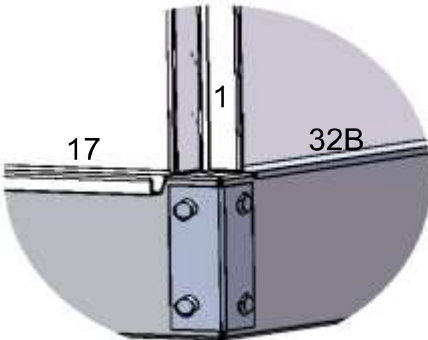

# NOTICE

Chère cliente, Cher client,

Nous vous remercions d'avoir choisi notre produit. Vous avez fait le bon choix en achetant l'un des articles de notre marque. Nos produits sont soumis à des contrôles réguliers et répondent naturellement aux exigences strictes de l'Union européenne afin d'offrir le haut niveau de qualité dont nous souhaitons vous faire profiter.

## TABLE DES MATIÈRES

SYMBOLES .....	55
INFORMATIONS GÉNÉRALES .....	55
UTILISATION CONFORME .....	56
CONSIGNES DE DÉBALLAGE.....	56
CHOIX DE L'EMPLACEMENT.....	57
CONSIGNES POUR L'INSTALLATION .....	57
CONSEILS DE MAINTENANCE ET D'ENTRETIEN .....	57
ÉLIMINATION.....	58
LISTE DE PIÈCE.....	59
LISTE DE PIÈCES PANNEAUX EN PC.....	61
MONTAGE DE LA LUCARNE .....	62
MONTAGE DU CADRE DE LA PORTE COULISSANTE .....	64
MONTAGE DU CADRE AVANT.....	66
MONTAGE PAROI GAUCHE .....	68
MONTAGE PAROI DROITE .....	70
MONTAGE DU CADRE DE LA PAROI ARRIÈRE.....	72
CONNEXION DES CADRES DES PAROIS.....	74
MONTAGE DU CADRE DE TOIT .....	76
PLACEMENT DES PANNEAUX PC TRANSPARENTS .....	78
MONTAGE DE LA PORTE COULISSANTE ET DE LA GOUTTIÈRE .....	80

## SYMBOLES



**VEUILLEZ LIRE LA NOTICE D'UTILISATION. INFORMATIONS IMPORTANTES. CONSERVEZ-LA POUR TOUTE UTILISATION ULTÉRIEURE !**

Veillez lire la notice attentivement et dans son intégralité avant la première utilisation. Conservez-la afin de pouvoir vous y reporter par la suite. Si vous devez un jour transmettre le produit à une autre personne, veillez à lui donner également la notice.



**ATTENTION ! DANGER POTENTIEL !**

Respectez les consignes de sécurité et la notice de montage afin d'éviter tout risque de blessures ou d'endommagements du produit.



**RISQUE D'ASPHYXIE !**

Conservez les petites pièces et les emballages hors de portée des enfants !



**MODIFICATION DU PRODUIT**

N'apportez jamais de modifications au produit ! Toute modification entraîne l'annulation de la garantie et peut rendre l'utilisation du produit risquée, voire dangereuse, dans le pire des cas.

## INFORMATIONS GÉNÉRALES

- Nous vous recommandons de monter le braséro à au moins 2 personnes.

- Assurez-vous de choisir un endroit qui présente également assez de place autour de l'abri de jardin pour travailler sans gêne.
- Suivez avec exactitude les instructions fournies pour chaque étape dans cette notice afin de garantir une construction correcte.
- Assurez-vous que toutes les pièces ont été livrées et sont à votre disposition avant de commencer le montage.
- Assurez-vous que le châssis de base se trouve à plat sur le sol.
- La base doit être droite. Si le sol présente des irrégularités, procédez à un nivelage.
- Votre serre doit être solidement ancrée sur sa fondation afin de prévenir tout dommage lié à des vents forts.
- **ATTENTION !** Ne montez pas sur son toit ! Risque d'effondrement !
- En cas d'utilisation d'une fondation qui n'est pas en béton coulé, il faut absolument s'assurer que la surface est solide et plane. Le produit doit être fixé avec/dans une fondation ! La durabilité et la stabilité de la serre dépend de sa mise en place précise. Si les parois sont ne serait-ce que légèrement obliques, elles ne peuvent pas tenir dans les guides fournis comme prévu et risquent d'être détachées des gonds en cas de vent.
- La fondation de la serre doit être obligatoirement ancrée/fixée dans le sol. La grande surface de la serre crée une grande surface d'appui pour le vent, ce qui peut provoquer des blessures et/ou des dommages matériels importants.
- Ne jamais faire de feu dans la serre et s'assurer qu'elle reste à l'écart d'étincelles et de flemmes nues !
- Ne pas utiliser ce produit en cas de pièces manquantes, endommagées ou usées.
- Faites très attention à ne pas enfermer de personnes et/ou d'animaux à l'intérieur de la serre !
- Évitez autant que faire se peut la présence d'arbres surplombant l'abri. Les feuilles que ces derniers perdent rendent un nettoyage régulier nécessaire et la chute de branches cassées peut représenter un danger pour l'abri.
- En revanche, de petits arbres, buissons, ou haies à proximité de celui-ci peuvent faire office de brise-vent.
- **AVERTISSEMENT !** En cas de vent et de tempête, les portes et les fenêtres doivent être fermées.

### UTILISATION CONFORME

La serre a été conçue pour la culture de légumes, de fleurs et d'autres plantes. Il n'est pas adapté au stockage de matières dangereuses ou au logement de personnes ou d'animaux. N'utilisez pas ce produit pour un usage autre que celui prévu. Le fabricant décline toute responsabilité pour tout dégât causé en raison d'une utilisation non conforme. Toute modification apportée au produit peut avoir des conséquences négatives en matière de sécurité et engendrer des risques et entraîne l'annulation de la garantie.

**Ce produit a uniquement été conçu pour un usage domestique et non pour un usage commercial.**

### CONSIGNES DE DÉBALLAGE

Ouvrez le carton, retirez toutes les pièces et éléments du set, et placez les composants sur la face supérieure du carton ou sur une autre surface propre. Cela protège votre nouveau produit. Une fois le produit déballé, vérifiez qu'il ne présente pas de dégâts et qu'il est complet. Aucune réclamation formulée tardivement ne sera acceptée.

## CHOIX DE L'EMPLACEMENT

Avant de débuter la construction, nous vous invitons à vous renseigner au sujet des dispositions et réglementations locales en vigueur. Afin de choisir l'endroit le plus approprié pour la construction de votre serre, assurez-vous que le sol y soit stable et droit et de ne pas choisir un endroit exposé où l'abri se tiendrait entièrement seul. Il faut prévoir une certaine protection contre les tempêtes et les rafales. Si votre abri est construit à un endroit isolé, il est possible qu'il subisse des dommages par temps venteux ou orageux.

## CONSIGNES POUR L'INSTALLATION

Suivez les graphiques des étapes de montage.



Pendant le montage, portez toujours des gants de sécurité, des manches longues, et un moyen de protection des yeux. Certaines pièces peuvent avoir des arêtes tranchantes et causer des blessures !

Scannez le code QR pour accéder  
directement à la vidéo de mise en place.

- Avant d'installer la serre, vous devez impérativement avoir mis en place une fondation adéquate. Vous pouvez trouver ce type de fondations (éléments auxiliaires de coffrage) dans notre boutique en ligne.
- Ne pas monter la serre avec du vent ou lorsqu'il fait humide.
- Retirez les pièces du carton et triez-les par numéro. Assurez-vous qu'aucune pièce nécessaire à l'installation ne manque.
- Prenez le temps pour vous familiariser avec le fonctionnement de tous les outils.
- Tenez vos enfants et animaux de compagnie éloignés du lieu de construction.
- Si vous utilisez une échelle, assurez-vous de sa stabilité. Ne vous appuyez jamais de tout votre poids sur une quelconque partie du toit ou toute autre partie de cette serre.
- Certaines étapes de montage nécessitent la présence de deux personnes.
- Gardez les petites pièces (vis, etc.) dans les cartons et les sachets pour qu'elles ne se perdent pas.
- Chaque pièce est numérotée ; la numérotation est expliquée dans la notice de montage.
- Commencez le montage en regroupant les pièces avec le même numéro autour du lieu de montage.
- Le cadre en aluminium de la serre est monté en premier et les panneaux en PC en dernier.

## CONSEILS DE MAINTENANCE ET D'ENTRETIEN

- Nettoyez le produit avec une éponge et de l'eau chaude savonneuse. N'utilisez pas de détergent ou de nettoyant à base de solvant, p. ex. de l'eau de Javel. Cela peut endommager le produit.
- Utilisez toujours le bon outil pour chaque intervention sur la serre.
- Remplacez sans délai les pièces endommagées de la serre ! Les pièces endommagées peuvent provoquer des blessures aux personnes et aux animaux !

- Veillez à garder le toit libre de neige en hiver dans la mesure du possible. Il pourrait s'effondrer sous une couche de neige trop importante. Une couche de neige de plus de 10 cm peut déjà être dangereuse (une couche de 36 cm de neige sèche, de 10 cm de neige aqueuse et de 5,5 cm de glace pèse environ à 50 kg/m<sup>2</sup>).
- En cas de problèmes imprévus adressez-vous à notre service après-vente. Nous serons ravis de vous aider.



## ÉLIMINATION

À l'issue de longues années de loyaux services, lorsque votre produit sera hors d'usage, veuillez en éliminer les matières premières recyclables de manière à ce qu'elles soient recyclées conformément à la réglementation applicable. Si vous avez un doute sur la meilleure façon de procéder, renseignez-vous auprès des entreprises qui gèrent les déchets dans votre localité ou des déchetteries de la région.



















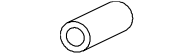
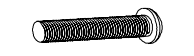
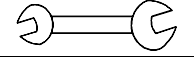



Le produit et l'emballage sont soumis aux directives de recyclage. Pour plus d'informations, rendez-vous sur : [quefairedemesdechets.fr](http://quefairedemesdechets.fr)

## LISTE DE PIÈCES (carton 1/2)



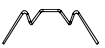

N°	Illustration	Quantité	Dimensions (mm)
1		4	1215
2		1	1134
3		1	1134
4		1	1134
5		1	1134
6		1	1647
7		1	1647
8		1	1655
9		1	1655
10		4	1215
11		4	1114
12		1	610
13		4	
14		1	1260
15		1	634
16		2	911
16A		1	170
17		1	1355
17A		1	467
17B		1	170





N°	Illustration	Quantité	Dimensions (mm)
18		2	
19		1	380
20		2	1608
21		4	1220
21A		4	610
21B		2	
22		4	1350
22A		2	1362
23		2	594
24		1	610
25		2	1304
26		2	610
27		1	610
28		2	520
29		1	608
30		1	595
31		1	595
32A		2	1432
32B		2	390
32C		2	170

N°	Illustration	Quantité	Dimensions (mm)
33		1	1433
33A		1	388
33C		1	170
34A		2	1433
34B		2	390
34C		2	170
35		5	603
36		2	
37		1	
38		1	M5x30
39		2	
40		138	M6x10

N°	Illustration	Quantité	Dimensions (mm)
41		14	M5x18
41A		2	M4x18
42		6	M4x8
44A		2	
44B		2	
45A		1	
45B		1	
46		1	
47		162	
48		137	M6
53		44	

## LISTE DE PIÈCES PANNEAUX EN PC (carton 2/2)

N°	Illustration	Quantité	Dimensions (mm)
1		11	605 x 1212
2		5	605 x 1130
3A		2	605 x 455
3B		2	605 x 455
4		1	605 x 585

N°	Illustration	Quantité	Dimensions (mm)
5		1	595 x 550
6		1	605 x 675
7		1	605 x 250
8		1	615 x 241
9		2	605 x 602

## CONSIGNES POUR LE MONTAGE DES PANNEAUX PC



Photo des panneaux PC de 4 mm

Les panneaux sont munis d'un film de protection blanc sans protection anti-UV d'un côté et d'un film de protection vert avec protection anti-UV de l'autre. Le côté vert doit être tourné vers l'extérieur.

Le film protège les panneaux. Nous vous conseillons donc de le retirer une fois que les panneaux sont montés dans le cadre de la serre afin que vous sachiez quel côté est protégé contre les UV de sorte à éviter de confondre les côtés pendant le montage.

Vous pouvez retirer environ 5 cm de film de protection sur tous les bords de la plaque avant de monter les panneaux dans le cadre (pour

qu'il n'y ait pas de film sous les vis et les rails en aluminium) et, une fois les panneaux installés dans le cadre, vous pourrez retirer entièrement les films de protection.

Manipulez les panneaux avec grand soin pour éviter les rayures pendant le montage.

Nous vous recommandons de préparer les outils suivants pour le montage :

- Gants de protection
- Mètre ruban
- Tournevis plat
- Visseuse sans fil



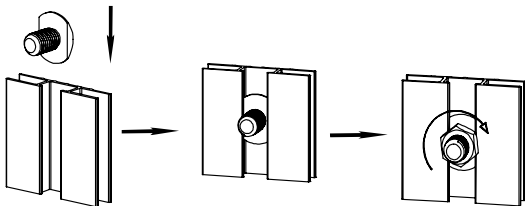

(Une clé à molette est fournie dans l'emballage.)







Comment faire glisser les vis dans les rainures des rails en aluminium.

## MONTAGE DE LA LUCARNE

Posez les pièces comme illustré ci-dessous : placez les vis (n° 40) du haut vers le bas, montez d'abord les pièces 28 et 31, puis la plaque (pièce 5) et ensuite la pièce 30.

N°	Illustration	Quantité	Dimensions (mm)
28		2	520
30		1	595
31		1	595
40		4	M6x10

N°	Illustration	Quantité	Dimensions (mm)
42		2	M4x8
46		1	
48		4	M6
5		1	595 x 550

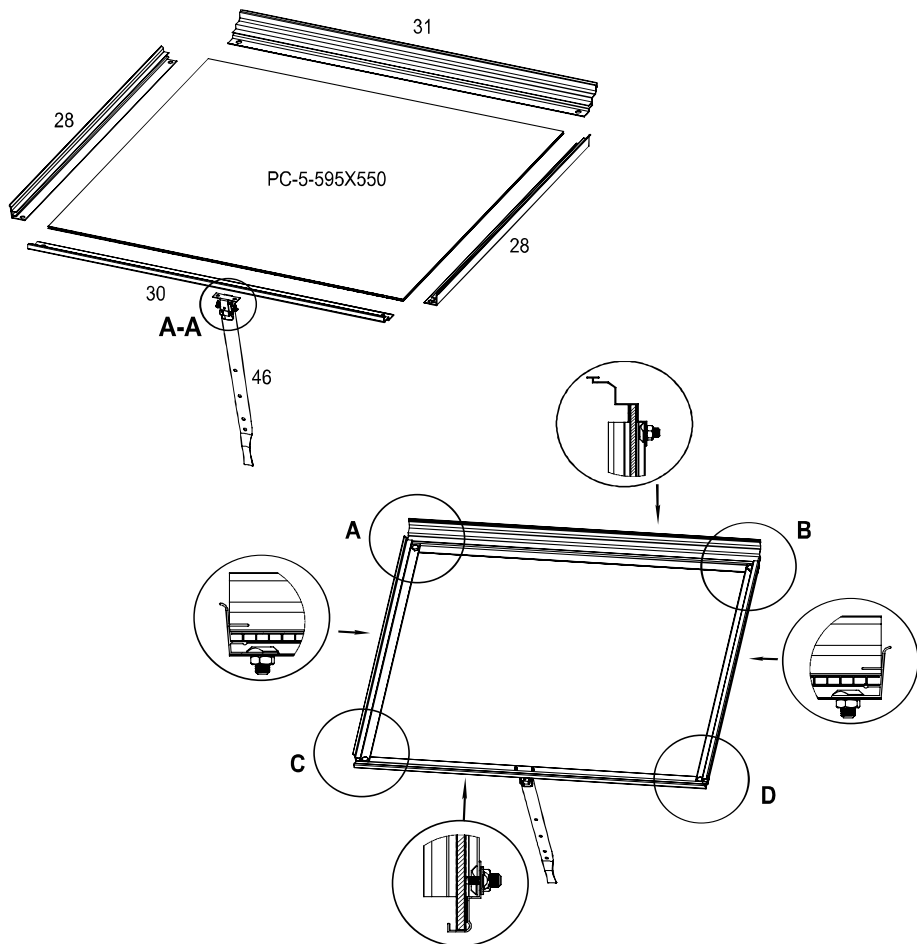

Le côté muni d'un film de protection vert anti-UV doit être orienté vers le soleil. Le côté muni d'un film blanc sans protection anti-UV doit être orienté vers l'intérieur de la serre.

**AA**

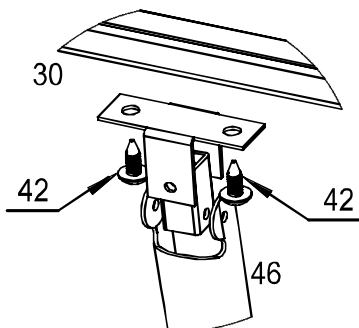

**A**

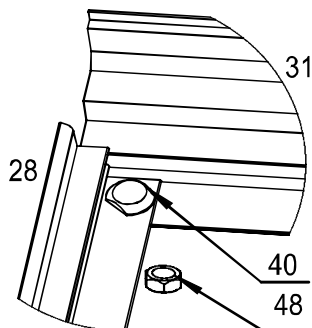

Fixez le support sur les trous de vis prévus à cet effet.

**B**

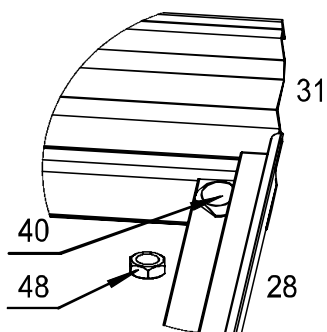

**C**

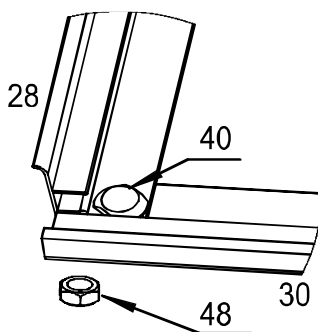

Serrez les vis et les écrous après avoir monté la pièce 30 dans la position définitive.

**D**

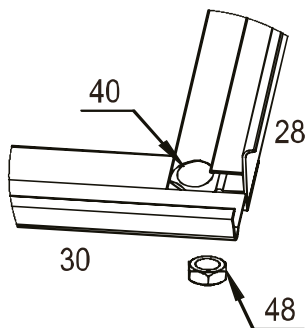

## MONTAGE DU CADRE DE LA PORTE COULISSANTE

N°	Illustration	Quantité	Dimensions (mm)
20		2	1608
24		1	610
26		2	610
27		1	610
29		1	608

N°	Illustration	Quantité	Dimensions (mm)
36		2	
40		2	M6x10
41		14	M5x18
41A		2	M4x18
48		2	M4x8

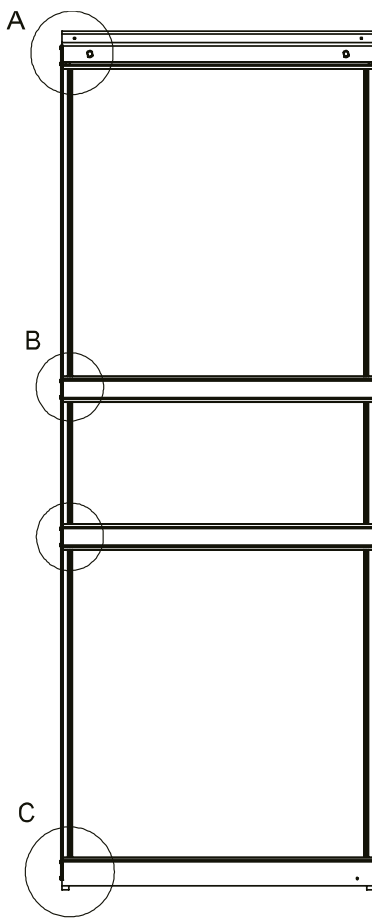
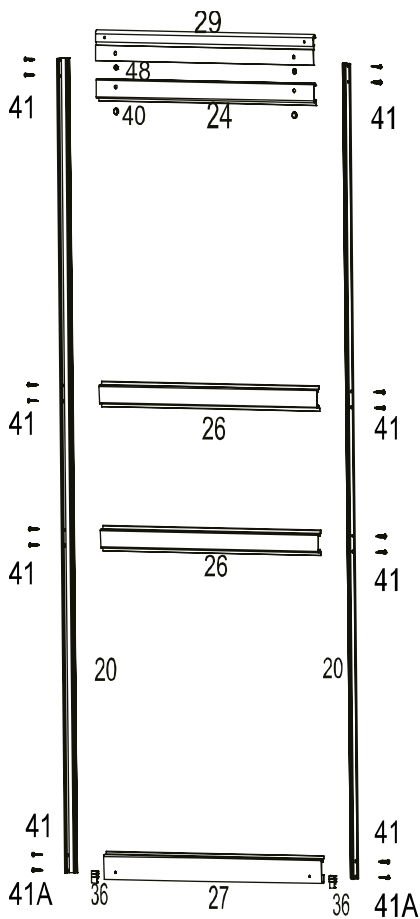

A

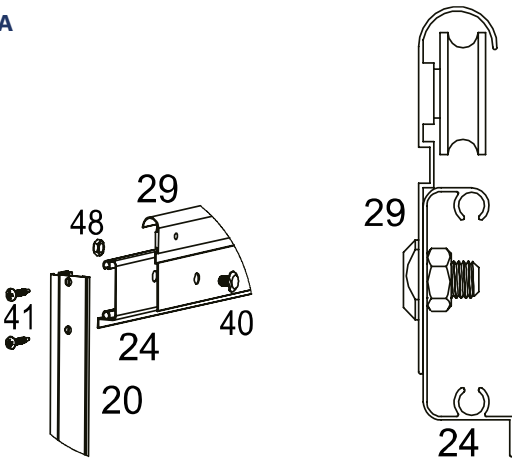

B

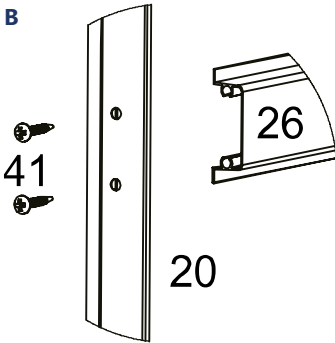

C

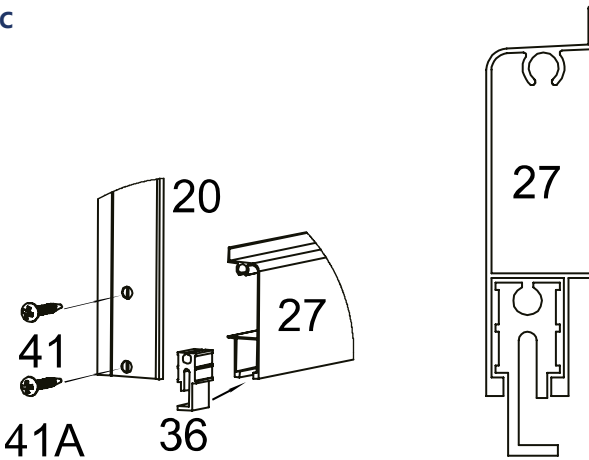

## MONTAGE DU CADRE AVANT

N°	Illustration	Quantité	Dimensions (mm)
1		2	1215
2		1	1134
3		1	1134
6		1	1647
7		1	1647
12		1	610
13		2	
14		1	1260
17		1	1335
17A		1	467

N°	Illustration	Quantité	Dimensions (mm)
17B		1	170
19		1	380
23		2	594
25		2	1304
37		1	
38		1	
40		26	M6x10
48		27	M6

Pour l'assemblage, veuillez suivre les consignes pour les pièces 2 et 3.  
Cadre avant vu de l'intérieur de la serre (vue de dessous).

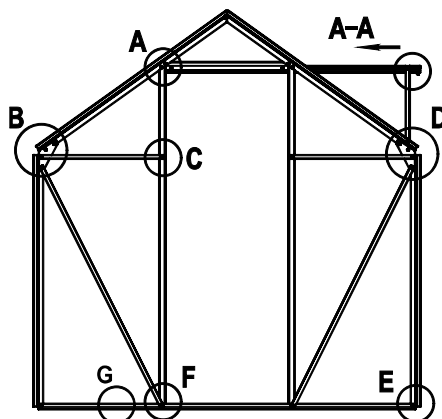
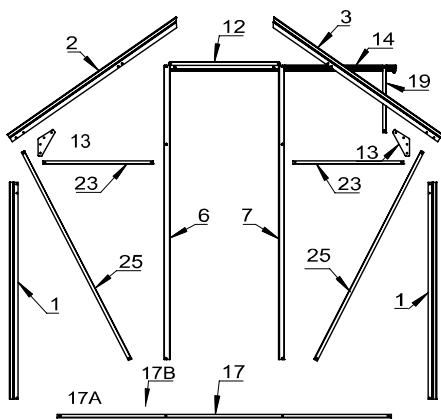

Vue de l'extérieur de la serre.

**AA**

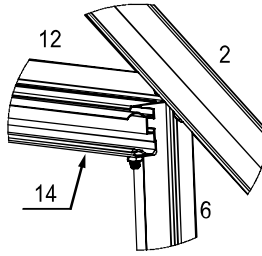
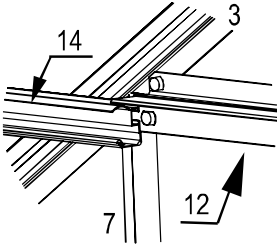
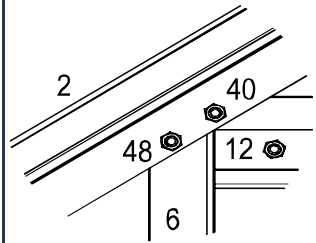

Image après l'installation de la pièce n° 14.

**A**



Partie A illustrée de l'intérieur ; veuillez respecter les sens de montage des pièces 40 et 48.

**B**

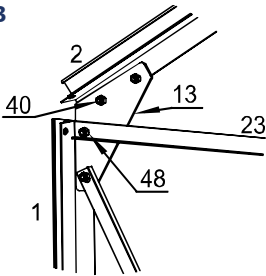

**C**

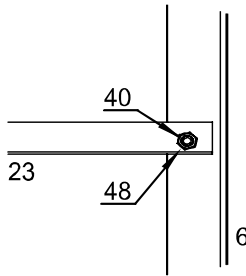

**D**

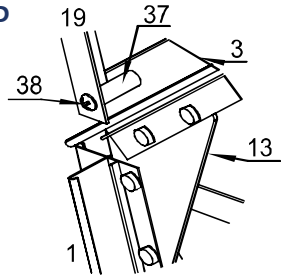

**E**

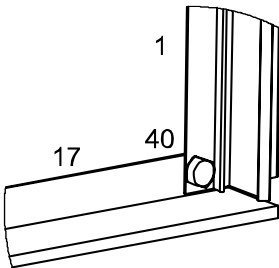

**F**

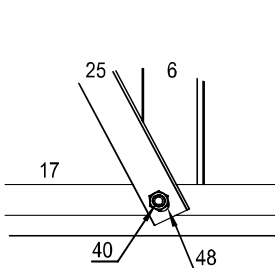



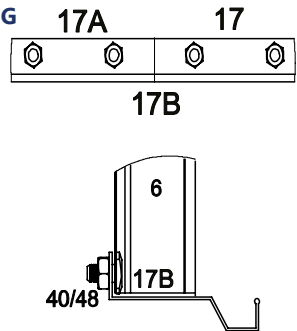





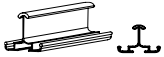
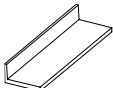

**G**

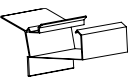

Vue détaillée

## MONTAGE PAROI GAUCHE (vue depuis la porte)

N°	Illustration	Quantité	Dimensions (mm)
10		2	1215
22		2	1304
22A		1	1362
21B		1	
32A		1	1432
32B		1	390
32C		1	170

N°	Illustration	Quantité	Dimensions (mm)
34A		1	1433
34B		1	390
34C		1	170
40		18	M6x10
48		18	M6

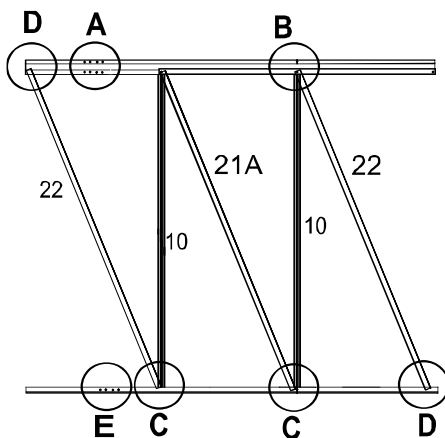
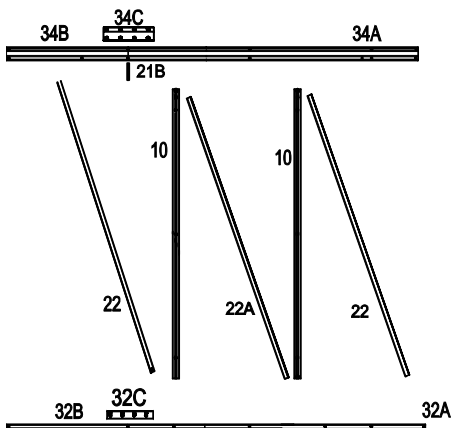

Commencez par monter les pièces indiquées dans les illustrations A et B.

Placez le mécanisme 21B entre 34A/34B, dans le sens indiqué par la flèche, et fixez avec 34C à l'aide de vis et d'écrous.

Veillez à serrer les vis avant de connecter les pièces 32 et 34 aux pièces 10, 21A et 22.

Paroi latérale vue de l'intérieur.

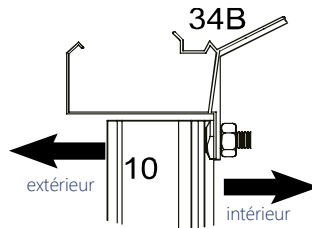
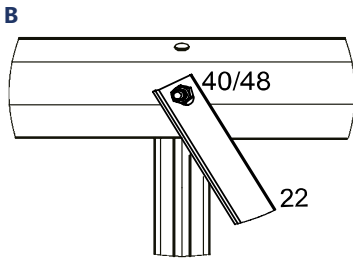
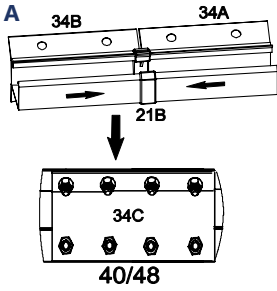

Vue détaillée

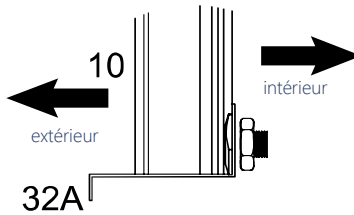
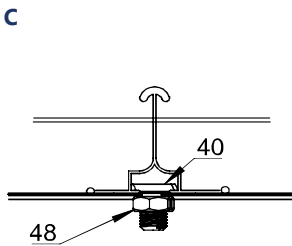

Fixation de la pièce 10 sur la pièce 32A

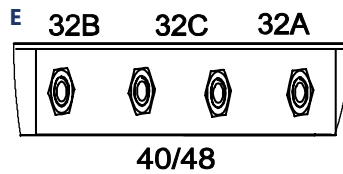
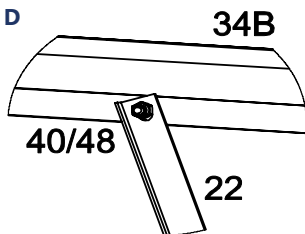

## MONTAGE PAROI DROITE (vue depuis la porte)

N°	Illustration	Quantité	Dimensions (mm)
10		2	1215
22		2	1304
22A		1	1362
21B		1	
32A		1	1432
32B		1	996
32C		1	170

N°	Illustration	Quantité	Dimensions (mm)
34A		1	1433
34B		1	390
34C		1	170
40		18	M6x10
48		18	M6

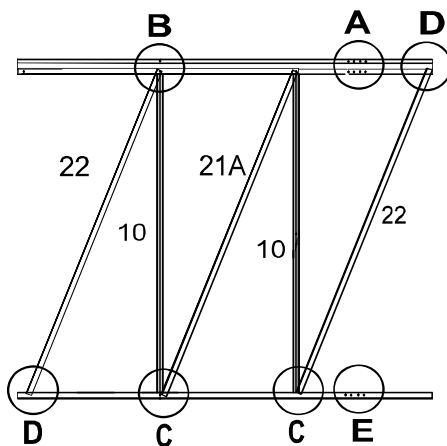
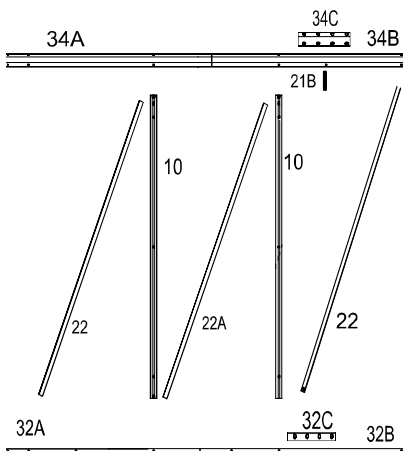

Commencez par monter les pièces indiquées dans les illustrations A et B.

Placez le mécanisme 21B entre 34A/34B, dans le sens indiqué par la flèche, et fixez avec 34C avec vis et écrous.

Veillez à serrer les vis avant de connecter les pièces 32 et 34 aux pièces 10, 21A et 22.

Paroi latérale vue de l'intérieur.

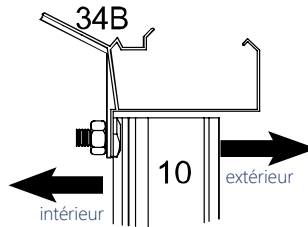
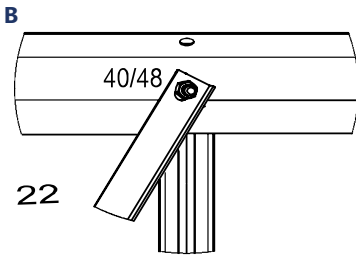
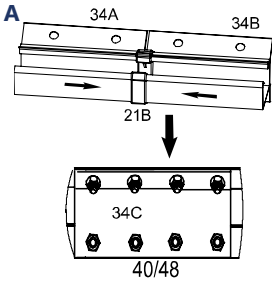

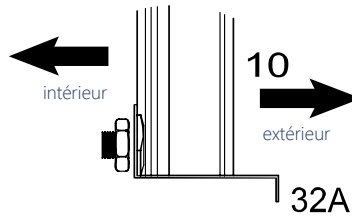
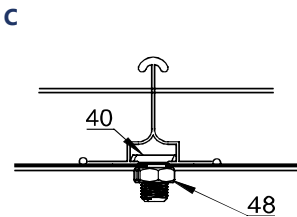

Vue détaillée



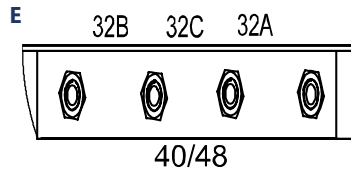
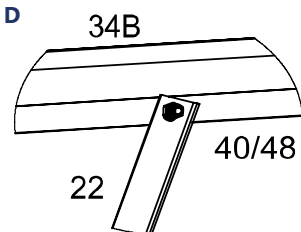

Fixation de la pièce 10 sur la pièce 32A

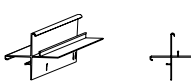
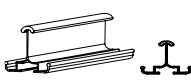

## MONTAGE DU CADRE DE LA PAROI ARRIÈRE

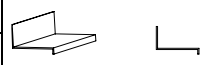
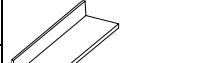
N°	Illustration	Quantité	Dimensions (mm)
1		2	1215
4		1	1134
5		1	1134
8		1	1655
9		1	1655
13		2	

N°	Illustration	Quantité	Dimensions (mm)
16		2	911
16A		1	170
21		2	1220
21A		2	610
40		24	M6x10
48		24	M6

Paroi arrière vue de l'intérieur

Les vis sont sécurisées de l'intérieur avec des écrous

Vissez les vis et les écrous selon les vues C et E

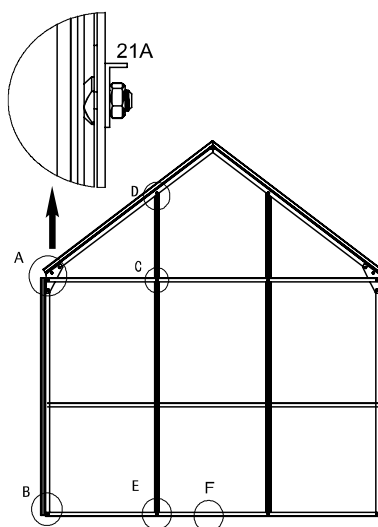
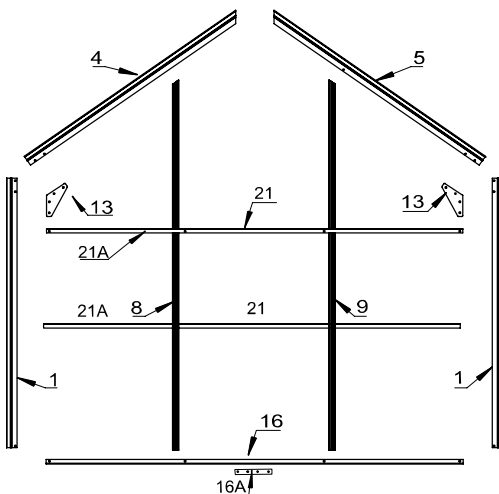

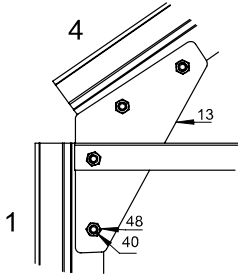
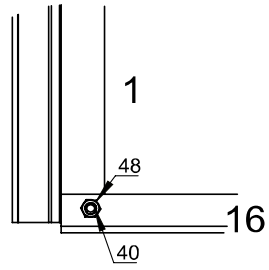
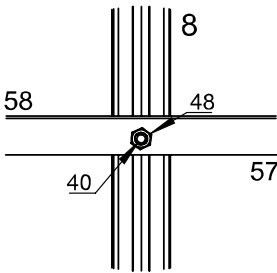
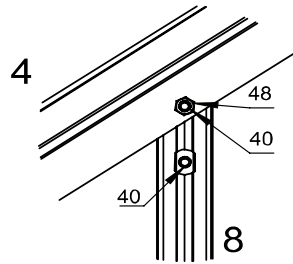
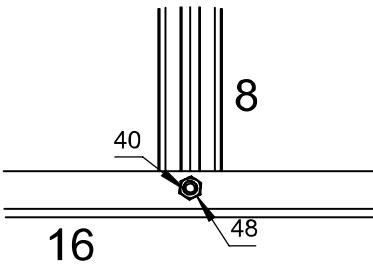
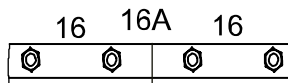
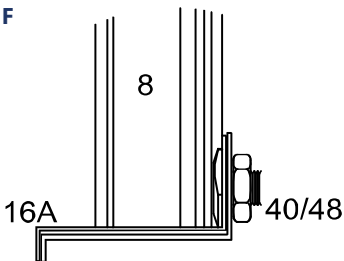
**A****B****C****D****E****F**

Vue détaillée

## CONNEXION DES CADRES DES PAROIS

N°	Illustration	Quantité	Dimensions (mm)
33		1	1433
33A		1	388
33C		1	170

N°	Illustration	Quantité	Dimensions (mm)
40		24	M6x10
48		24	M6

Pour assembler les éléments de cadre, il faut au moins 2 à 3 personnes.

Veillez respecter l'ordre des profilés en aluminium indiqué ci-dessous et utiliser des vis pour la fixation.

Une fois le montage des cadres des parois terminé, assemblez le faîtiage en utilisant la pièce 33.

La stabilité définitive de la serre est obtenue lorsque toutes les vis ont été vissées dans le cadre en aluminium et que les panneaux ont été montés.

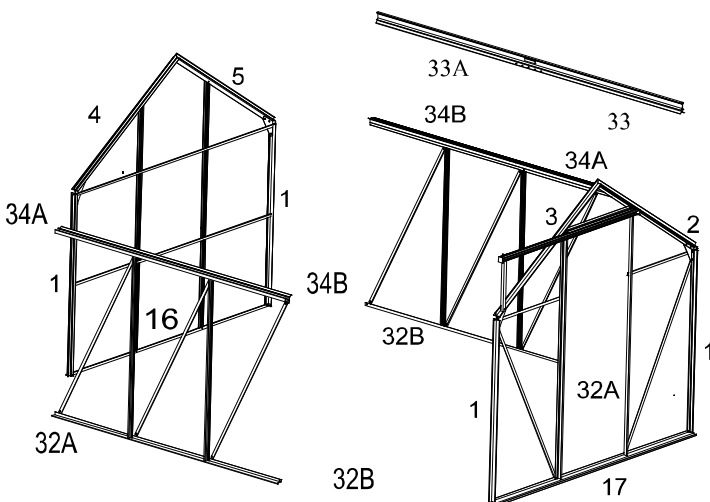
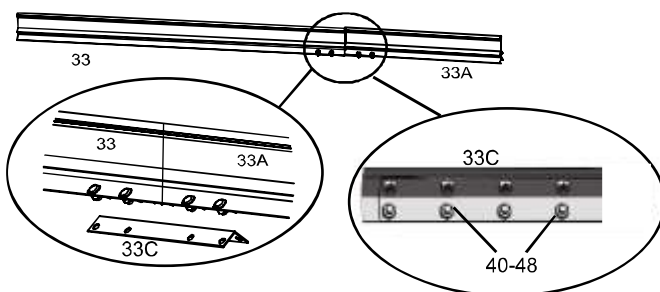

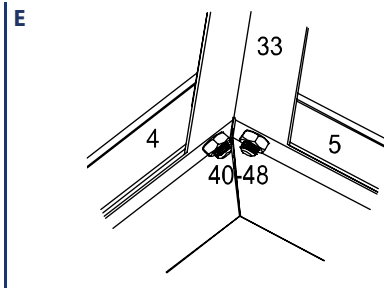
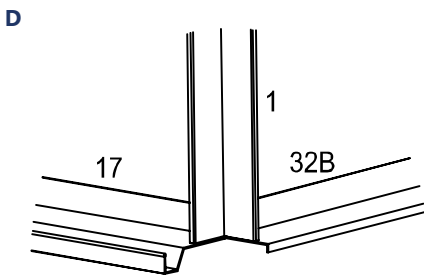
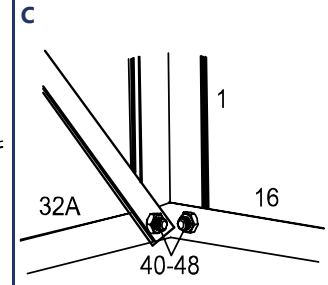
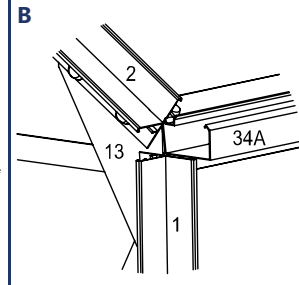
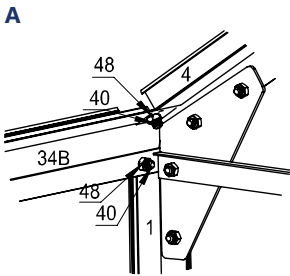
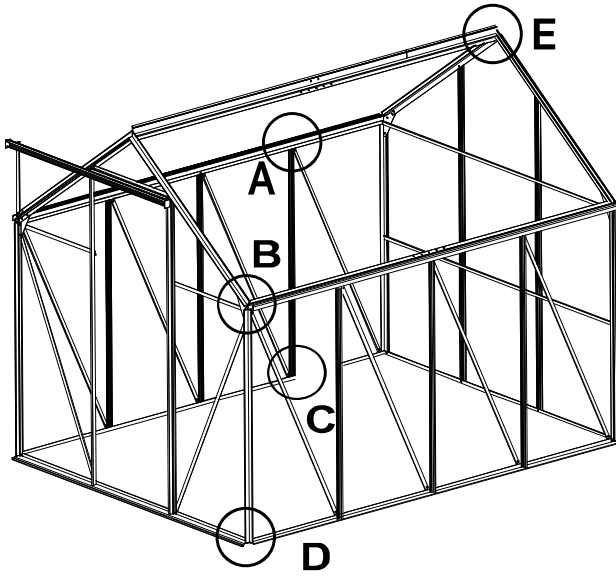

## MONTAGE DU CADRE DE TOIT

N°	Illustration	Quantité	Dimensions (mm)
11		4	1114
15		1	634
18		2	
21		2	1220
21A		2	610





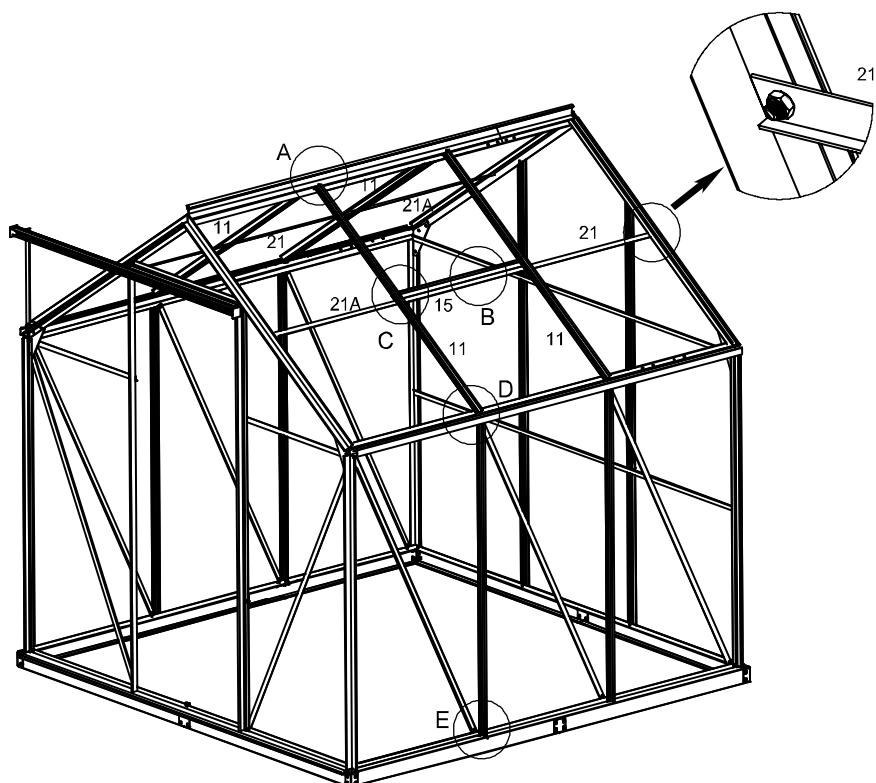

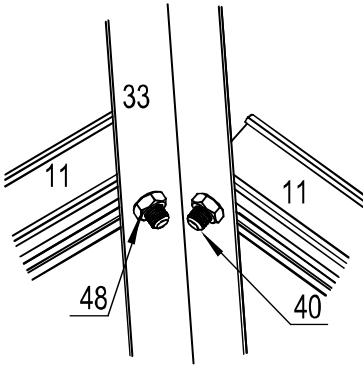
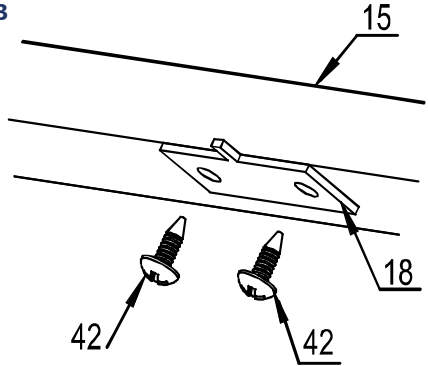
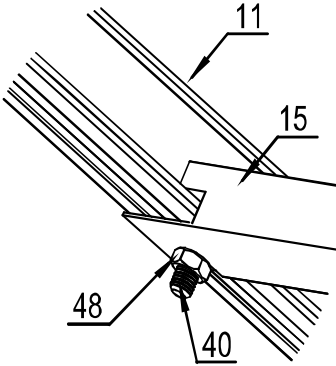
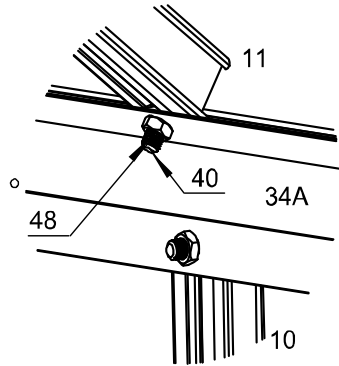
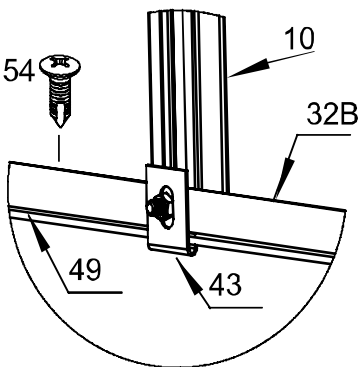
N°	Illustration	Quantité	Dimensions (mm)
40		18	M6x10
42		4	M4x18
43		16	
48		18	M6
54		16	







Il faut utiliser la pièce 43 pour connecter le sol de la serre à la fondation.



**A****B****C****D****E**

## PLACEMENT DES PANNEAUX PC TRANSPARENTS

N°	Illustration	Quantité	Dimensions (mm)
1		11	605 x 1212
2		5	605 x 1130
3A		2	605 x 455
3B		2	605 x 455
4		1	605 x 585
5		1	595 x 550
6		1	605 x 675

N°	Illustration	Quantité	Dimensions (mm)
7		1	605 x 250
8		1	615 x 241
9		2	605 x 602
35		5	
47		162	
53		44	

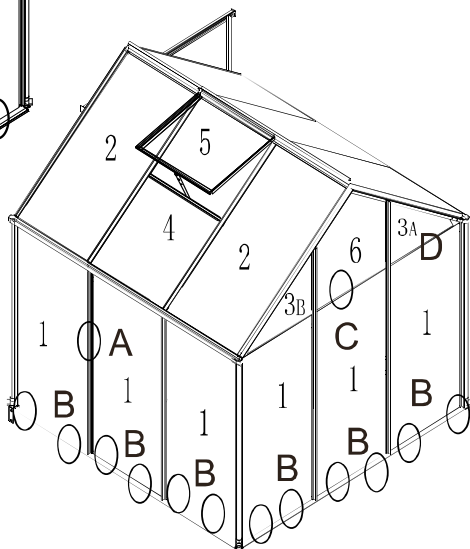
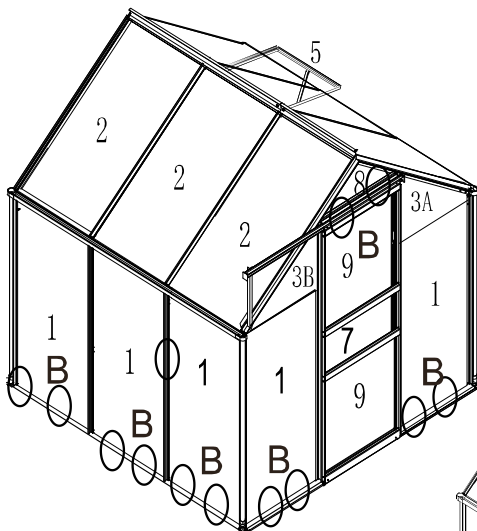

A



B

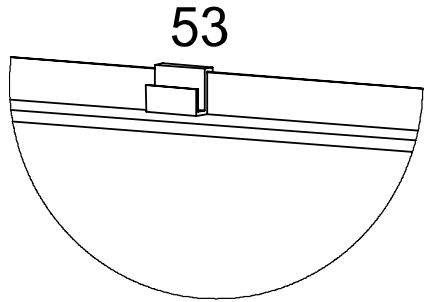

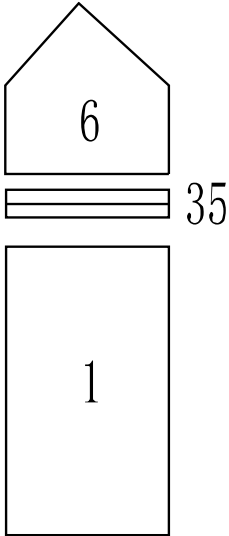

C



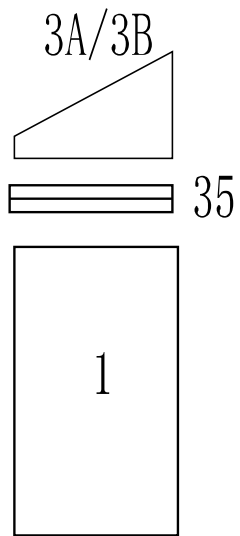

D



## MONTAGE DE LA PORTE COULISSANTE ET DE LA GOUTTIÈRE

N°	Illustration	Quantité	Dimensions (mm)
44A		2	
44B		2	
45A		1	

N°	Illustration	Quantité	Dimensions (mm)
45B		1	
40		2	M6x10
48		2	M6

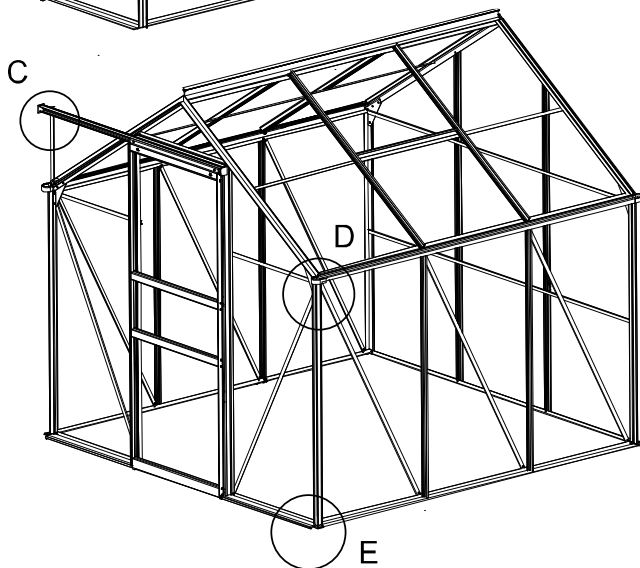
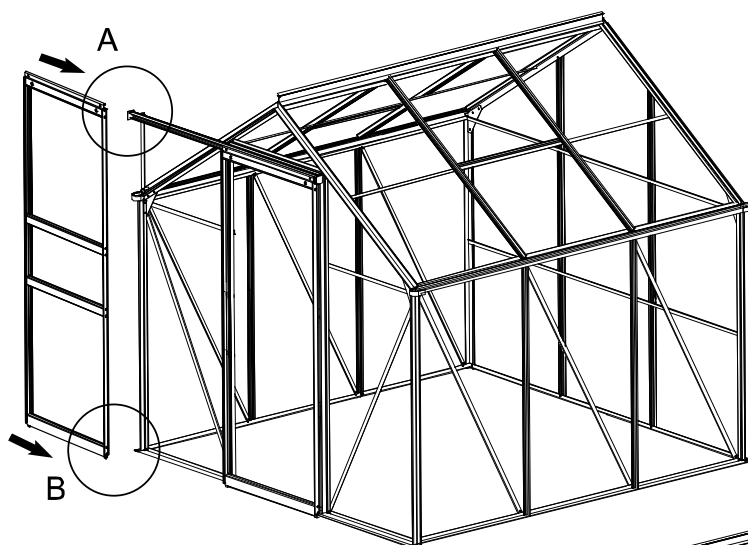

A

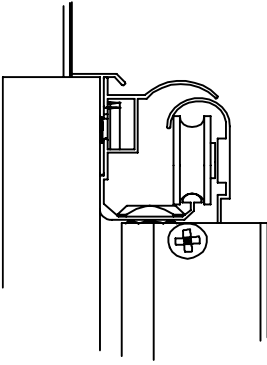

B

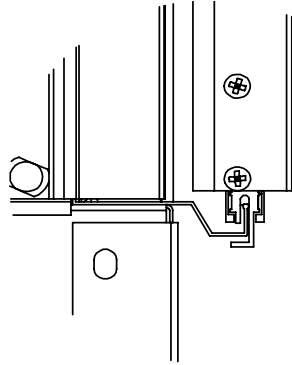

C

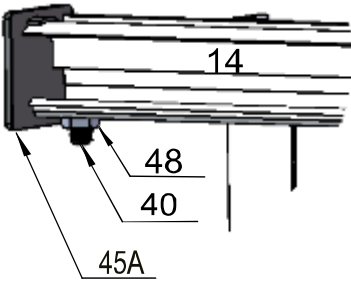

D

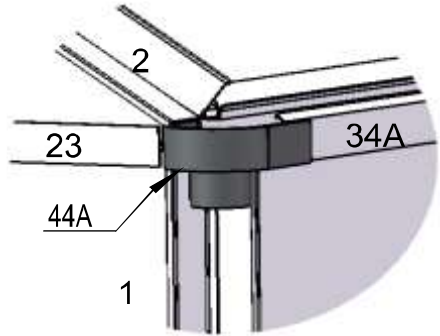

E

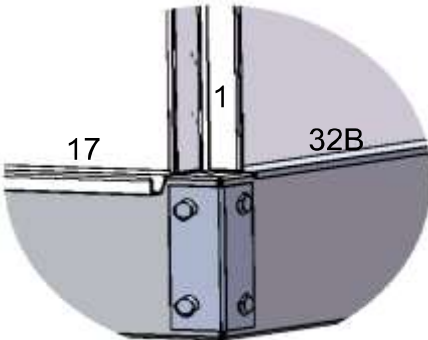

# ISTRUZIONI

## Gentile cliente,

grazie per aver scelto il nostro articolo, con l'acquisto di un nostro prodotto ha compiuto un'ottima scelta. Al fine di soddisfare gli elevati standard qualitativi richiesti, i nostri articoli sono sottoposti a controlli periodici e sono naturalmente sempre in linea con i rigorosi requisiti previsti dall'Unione Europea.

## INDICE

SIMBOLI .....	82
AVVERTENZE GENERALI.....	82
UTILIZZO CONFORME ALLA DESTINAZIONE D'USO .....	83
ISTRUZIONI DI DISIMBALLAGGIO.....	83
SCELTA DELLA POSIZIONE.....	83
ISTRUZIONI DI MONTAGGIO .....	83
ISTRUZIONI DI CURA E MANUTENZIONE.....	84
SMALTIMENTO.....	84
ELENCO PARTI .....	85
ELENCO PARTI PANNELLI IN POLICARBONATO .....	87
MONTAGGIO DEL LUCERNARIO.....	88
MONTAGGIO DEL TELAIO DELLA PORTA SCORREVOLE .....	90
MONTAGGIO DEL TELAIO ANTERIORE.....	92
MONTAGGIO DELLA PARETE SINISTRA.....	94
MONTAGGIO DELLA PARETE DESTRA .....	96
MONTAGGIO DEL TELAIO DELLA PARETE POSTERIORE.....	98
COLLEGAMENTO DEI TELAI DELLE PARETI.....	100
MONTAGGIO DEL TELAIO DEL TETTO .....	102
FISSAGGIO DEI PANNELLI TRASPARENTI IN POLICARBONATO .....	104
MONTAGGIO DELLA PORTA SCORREVOLE E DELLA GRONDAIA .....	106

## SIMBOLI



### LEGGERE LE ISTRUZIONI PER L'USO. AVVERTENZE IMPORTANTI. CONSERVARE PER UN USO FUTURO.

Prima del primo utilizzo, leggere attentamente e integralmente le istruzioni. Conservare le presenti istruzioni per consultazioni future. In caso di cessione del prodotto a terzi, assicurarsi di consegnare anche le presenti istruzioni.



### ATTENZIONE! POTENZIALE PERICOLO!

Osservare le avvertenze di sicurezza e le istruzioni di montaggio per evitare il rischio di lesioni o danni al prodotto.



### PERICOLO DI SOFFOCAMENTO!

Tenere le parti più piccole e il materiale d'imballaggio lontano dalla portata dei bambini!



### MODIFICHE AL PRODOTTO

Non apportare in nessun caso modifiche al prodotto! Eventuali modifiche possono invalidare la garanzia e rendere il prodotto non sicuro o addirittura pericoloso.

### AVVERTENZE GENERALI

- Si consiglia di eseguire le operazioni di montaggio in almeno 2 persone.
- Scegliere un luogo che offra uno spazio sufficiente per lavorare attorno alla serra.

- Seguire i passaggi descritti nelle istruzioni per eseguire un assemblaggio corretto.
- Prima di iniziare il montaggio assicurarsi che tutte le parti siano presenti.
- Accertarsi che il telaio di base poggia completamente sul suolo.
- La base deve essere in piano. Se il suolo dovesse presentare delle irregolarità, spianarlo.
- La serra deve essere ancorata in modo fisso alla base per evitare danni causati dal vento forte.
- **ATTENZIONE!** Non calpestare il tetto! Pericolo di cedimento strutturale!
- Se si utilizza una fondazione diversa dal calcestruzzo, è necessario assicurarsi che la superficie sia solida e piana. Il prodotto deve essere fissato con una fondazione! La serra potrà reggersi in modo stabile e duraturo solo se allineata correttamente. È sufficiente che le pareti siano leggermente inclinate perché non siano più tenute correttamente nelle apposite guide e possano venire facilmente sganciate dai cardini a causa del vento.
- Le fondamenta della serra devono essere assolutamente ancorate/fissate al terreno. L'ampia superficie della serra offre una vasta area di attacco al vento, che può provocare notevoli lesioni e/o danni alle cose.
- Non accendere mai fuochi nella serra e tenerla al riparo da fiamme libere e scintille!
- Non utilizzare il prodotto in caso di parti mancanti, danneggiate o usurate.
- Fare particolare attenzione che persone e/o animali non rimangano chiusi nella serra!
- Evitare per quanto possibile la sporgenza di alberi, poiché le foglie cadute richiedono una pulizia regolare e la rottura dei rami è fonte di pericolo.
- Piccoli alberi, arbusti o recinti nelle vicinanze possono essere utili come frangivento.
- **AVVERTENZA!** In caso di vento e tempesta, le porte e le finestre devono essere chiuse.

### UTILIZZO CONFORME ALLA DESTINAZIONE D'USO

La serra è stata concepita per la coltivazione di ortaggi, fiori e altre piante. La serra non è adatta al deposito di sostanze pericolose e al ricovero di persone o animali. Utilizzare il prodotto solo per lo scopo previsto. Il produttore declina qualsiasi responsabilità per danni derivanti da un uso improprio del prodotto. Qualsiasi modifica al prodotto può influire negativamente sulla sicurezza, causare pericoli e invalidare la garanzia.

**Solo per uso domestico e non adatto a un utilizzo commerciale.**

### ISTRUZIONI DI DISIMBALLAGGIO

Aprire il cartone di imballaggio, estrarre tutte le parti e posizionarle sulla parte superiore del cartone o su un'altra superficie pulita. Questa operazione servirà a proteggere il vostro nuovo prodotto. Dopo aver disimballato il prodotto verificare che sia integro e non presenti danni. Reclami tardivi non potranno essere accettati.

### SCelta DELLA POSIZIONE

Prima di procedere al montaggio, familiarizzare con le norme e ordinanze locali. Nella scelta del luogo più adatto per l'installazione della serra, assicurarsi che il terreno sia stabile e in piano e accertarsi che non sia un punto esposto in cui la serra si trovi completamente isolata. Deve essere garantito un certo grado di protezione da tempeste e raffiche di vento. L'eccessiva esposizione può causare danni.

### ISTRUZIONI DI MONTAGGIO

Per effettuare il montaggio, seguire lo schema relativo alle diverse fasi.



Durante le operazioni di montaggio indossare sempre guanti protettivi, indumenti con maniche lunghe e occhiali protettivi. Alcune parti potrebbero presentare bordi taglienti e quindi provocare lesioni!

Scansionare il codice QR per consultare il video di montaggio.

- Prima di montare la serra, è fondamentale preparare una fondazione adeguata. Le fondazioni (ausili per casseforme) possono essere acquistate nel nostro negozio online.
- Non montare la serra in condizioni di vento o umidità.
- Rimuovere le parti dalla scatola e ordinarle in base al numero. Assicurarsi di disporre di tutte le parti necessarie per il montaggio.
- Acquisire familiarità con il funzionamento di tutti gli strumenti.
- Tenere i bambini e gli animali domestici lontani dal luogo di montaggio.
- Se si utilizza una scala, verificare che sia stabile. Non appoggiarsi mai con tutto il peso del corpo su una parte qualsiasi del tetto o della serra.
- Alcune fasi di montaggio richiedono due persone.
- Conservare le parti piccole (viti, ecc.) nelle scatole e nei sacchetti per evitare che vadano perse.
- Ogni parte è numerata e il numero corrispondente è riportato nelle istruzioni di montaggio.
- Iniziare il montaggio disponendo le parti con lo stesso numero in gruppi separati intorno al sito di installazione.
- Il telaio in alluminio della serra viene assemblato per primo e i pannelli in policarbonato vengono installati per ultimi.

### **ISTRUZIONI DI CURA E MANUTENZIONE**

- Per la pulizia utilizzare una spugna con acqua calda e sapone. Non utilizzare detersivi contenenti solventi o detersivi, ad es. candeggina, in quanto possono danneggiare il prodotto.
- Per tutti i lavori sulla serra, utilizzare sempre strumenti adeguati.
- Sostituire immediatamente le singole parti danneggiate della serra! Persone e animali possono subire lesioni a causa di parti danneggiate!
- In inverno, assicurarsi che il tetto rimanga il più possibile privo di neve. Se il carico di neve è eccessivo, il tetto potrebbe cedere. Una profondità della neve superiore a 10 cm può già risultare pericolosa (strato alto 36 cm con neve asciutta, 10 cm con neve acquosa e 5,5 cm con ghiaccio corrispondono a un peso di circa 50 kg/m<sup>2</sup>).
- In caso di problemi inaspettati, rivolgersi al nostro servizio di assistenza. Saremo lieti di aiutare.











### **SMALTIMENTO**

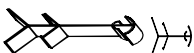

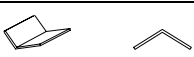

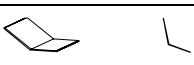

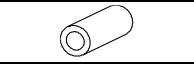
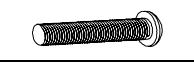
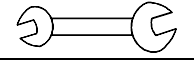



Al termine del lungo ciclo di vita dell'articolo provvedere al corretto smaltimento delle preziose materie prime per permetterne il regolare riciclaggio. In caso di dubbi rivolgersi ai centri di raccolta e smaltimento presenti nella propria zona.

**ELENCO PARTI** (scatola 1/2)





N.	Figura	Quantità	Dimensioni (mm)
1		4	1215
2		1	1134
3		1	1134
4		1	1134
5		1	1134
6		1	1647
7		1	1647
8		1	1655
9		1	1655
10		4	1215
11		4	1114
12		1	610
13		4	
14		1	1260
15		1	634
16		2	911
16A		1	170
17		1	1355
17A		1	467
17B		1	170





N.	Figura	Quantità	Dimensioni (mm)
18		2	
19		1	380
20		2	1608
21		4	1220
21A		4	610
21B		2	
22		4	1350
22A		2	1362
23		2	594
24		1	610
25		2	1304
26		2	610
27		1	610
28		2	520
29		1	608
30		1	595
31		1	595
32A		2	1432
32B		2	390
32C		2	170

N.	Figura	Quantità	Dimensioni (mm)
33		1	1433
33A		1	388
33C		1	170
34A		2	1433
34B		2	390
34C		2	170
35		5	603
36		2	
37		1	
38		1	M5x30
39		2	
40		138	M6x10

N.	Figura	Quantità	Dimensioni (mm)
41		14	M5x18
41A		2	M4x18
42		6	M4x8
N.	Figura	Quantità	Dimensioni (mm)
44A		2	
44B		2	
45A		1	
45B		1	
46		1	
47		162	
48		137	M6
53		44	

## ELENCO PARTI PANNELLI IN POLICARBONATO (cartone 2/2)

N.	Figura	Quantità	Dimensioni (mm)
1		11	605 x 1212
2		5	605 x 1130
3A		2	605 x 455
3B		2	605 x 455
4		1	605 x 585

N.	Figura	Quantità	Dimensioni (mm)
5		1	595 x 550
6		1	605 x 675
7		1	605 x 250
8		1	615 x 241
9		2	605 x 602

## ISTRUZIONI PER IL MONTAGGIO DEI PANNELLI IN POLICARBONATO



Foto dei pannelli in policarbonato da 4 mm

I pannelli presentano un lato con pellicola protettiva bianca senza protezione UV e un lato verde con protezione UV. Il lato verde deve trovarsi all'esterno.

La pellicola protegge i pannelli, pertanto si consiglia di rimuovere la pellicola protettiva solo dopo che i pannelli sono stati inseriti nel telaio della serra, così da sapere quale lato è protetto dai raggi UV e non confondere i lati durante l'installazione.

È consigliabile rimuovere circa 5 cm di pellicola protettiva da tutti i bordi del pannello prima di montarlo nel telaio di alluminio (in modo che non finisca sotto le viti e le strisce di alluminio); una volta fissato il pannello nel telaio, è possibile rimuovere completamente la pellicola protettiva.

Maneggiare i pannelli con particolare attenzione per evitare di graffiarli durante il montaggio.

Si consiglia di tenere a portata di mano i seguenti strumenti per il montaggio:

- Guanti protettivi
- Metro a nastro
- Cacciavite a testa piatta
- Cacciavite a batteria



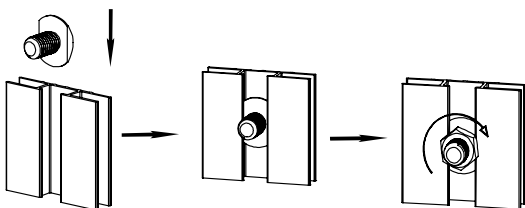

(Nella confezione è inclusa una chiave).





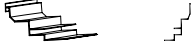

Così è possibile fare scorrere le viti nelle scanalature delle strisce di alluminio.

## MONTAGGIO DEL LUCERNARIO

Posizionare le parti come indicato di seguito, inserire le viti (n. 40) dall'alto verso il basso, montare prima le parti 28 e 31, quindi la piastra (parte 5) e nel passaggio successivo la parte 30.

N.	Figura	Quantità	Dimensioni (mm)
28		2	520
30		1	595
31		1	595
40		4	M6x10

N.	Figura	Quantità	Dimensioni (mm)
42		2	M4x8
46		1	
48		4	M6
5		1	595 x 550

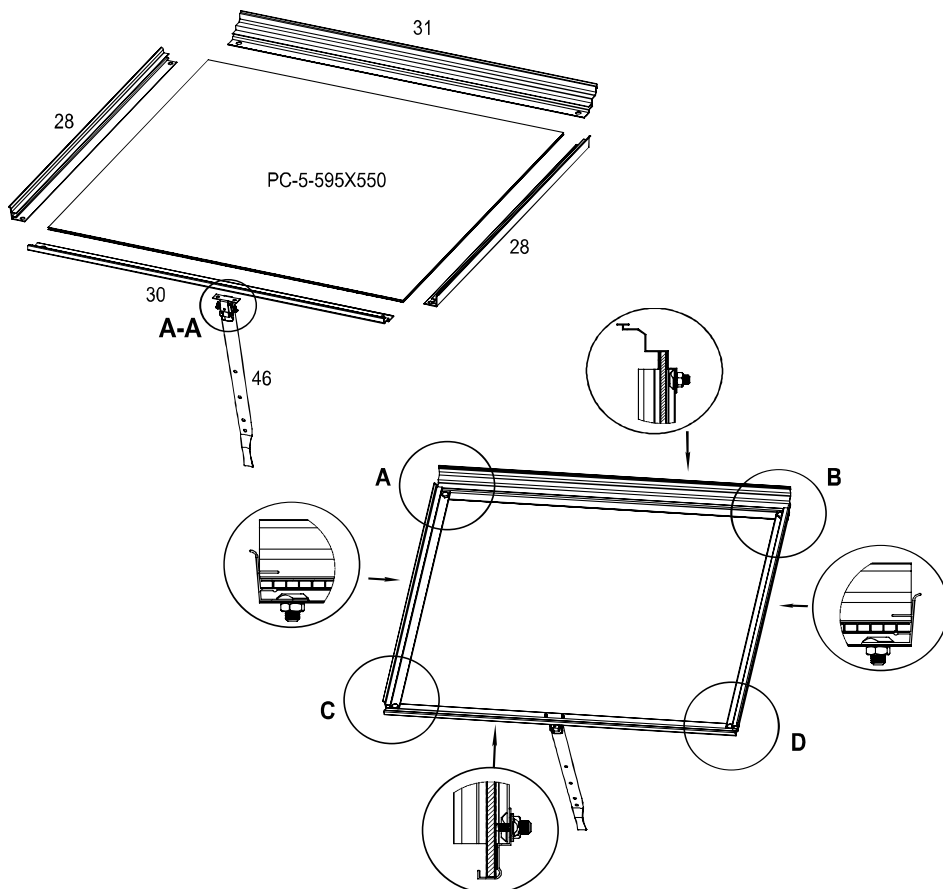

Il lato verde della pellicola protettiva con protezione UV deve essere rivolto verso il sole. Il lato bianco della pellicola protettiva senza protezione UV verso l'interno della serra.

**AA**

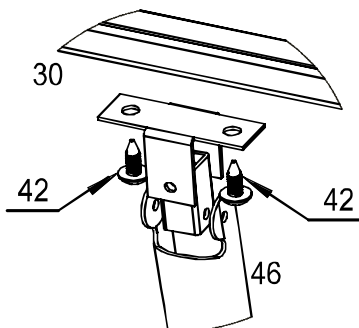

**A**

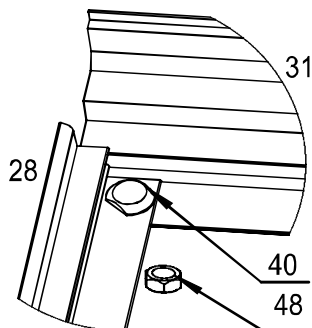

Fissare la staffa ai fori delle viti in dotazione.

**B**

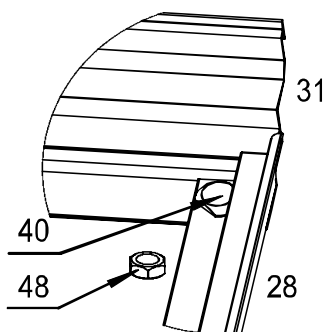

**C**

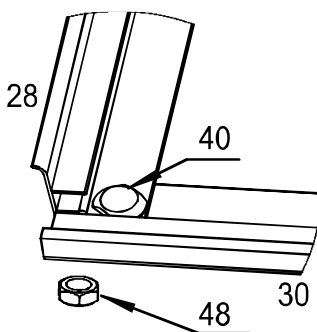

Serrare la vite e il dado solo dopo aver inserito la parte 30 nell'apposita posizione.

**D**

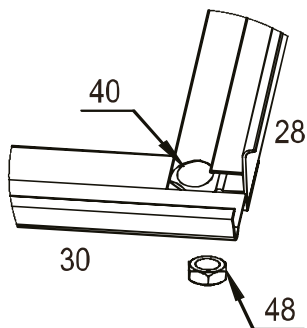



A

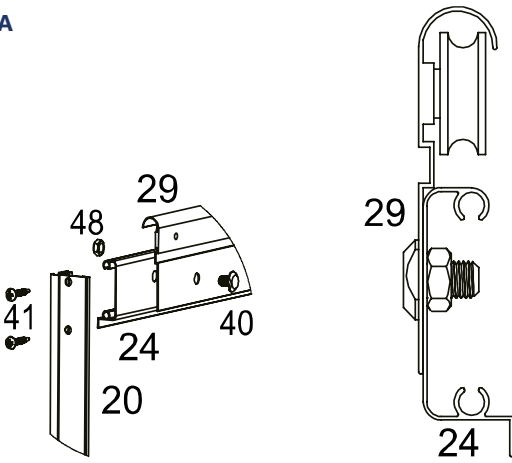

B

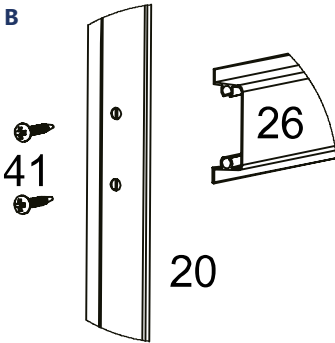

C

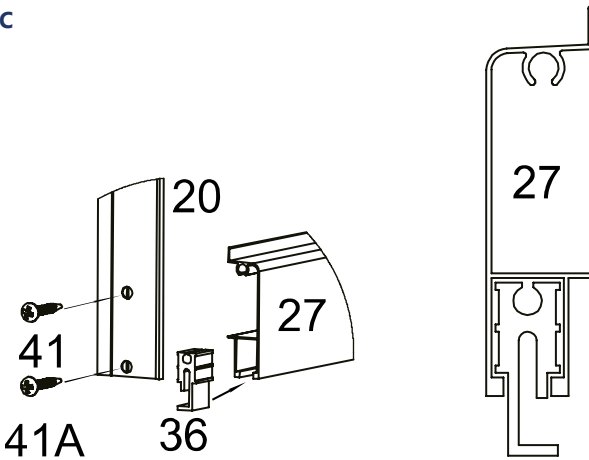

## MONTAGGIO DEL TELAIO ANTERIORE

N.	Figura	Quantità	Dimensioni (mm)
1		2	1215
2		1	1134
3		1	1134
6		1	1647
7		1	1647
12		1	610
13		2	
14		1	1260
17		1	1335
17A		1	467

N.	Figura	Quantità	Dimensioni (mm)
17B		1	170
19		1	380
23		2	594
25		2	1304
37		1	
38		1	
40		26	M6x10
48		27	M6

Per il montaggio, seguire le istruzioni relative alla parte 2 e alla parte 3.  
 Telaio anteriore visto dall'interno della serra (immagini in basso).

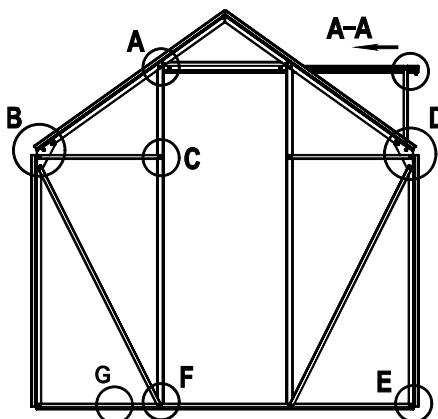
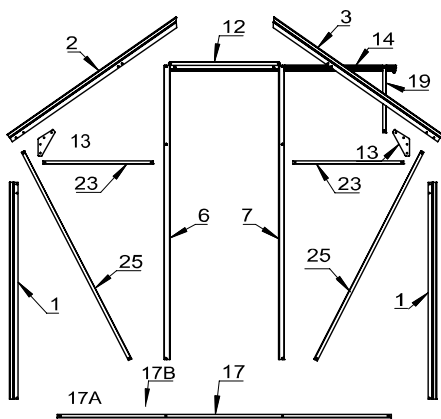

Vista dall'esterno della serra.

**AA**



Immagine dopo l'installazione della parte n. 14.

**A**

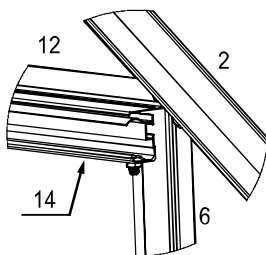
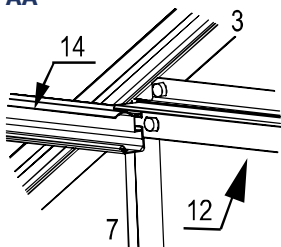
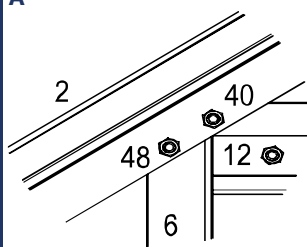

La sezione A mostra l'interno, notare le direzioni di montaggio delle parti 40 e 48.

**B**

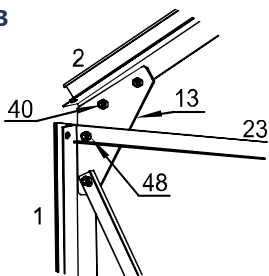

**C**

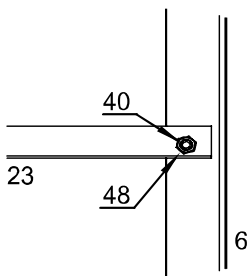

**D**

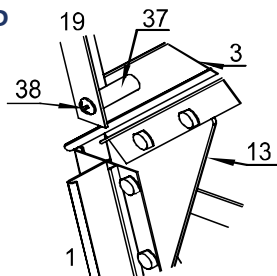

**E**

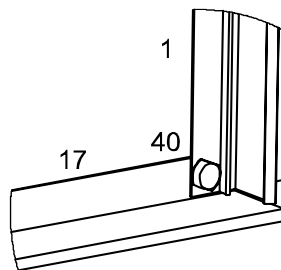

**F**

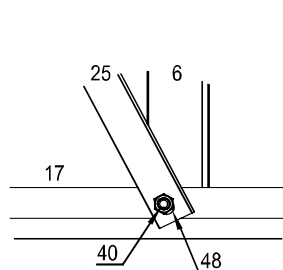

**G**

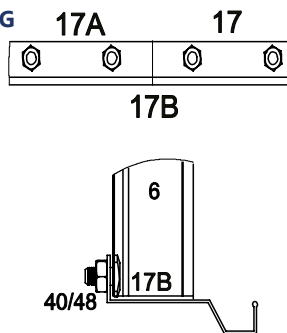

Vista dettagliata

## MONTAGGIO DELLA PARETE SINISTRA (vista dalla porta)

N.	Figura	Quantità	Dimensioni (mm)
10		2	1215
22		2	1304
22A		1	1362
21B		1	
32A		1	1432
32B		1	390
32C		1	170

N.	Figura	Quantità	Dimensioni (mm)
34A		1	1433
34B		1	390
34C		1	170
40		18	M6x10
48		18	M6

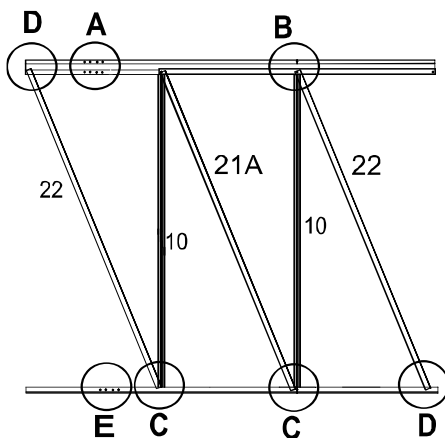
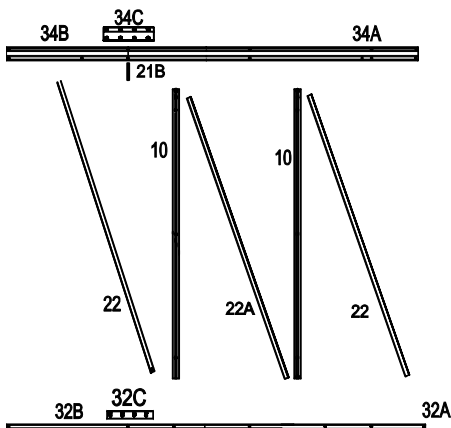

Montare prima le figure A ed E.

Inserire il raccordo 21B tra 34A/34B in direzione della freccia e fissarlo con 34C utilizzando viti e dadi.

Prima di collegare le parti 32 e 34 alle parti 10, 21A e 22, serrare le viti.

Parete laterale vista dall'interno.

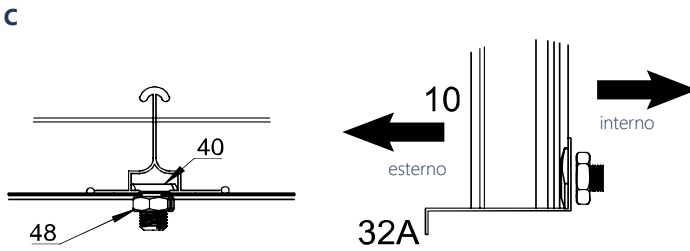
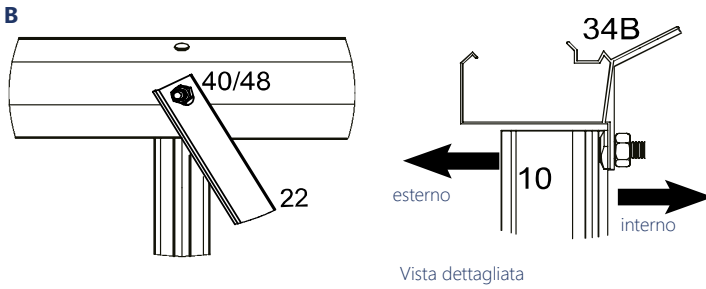
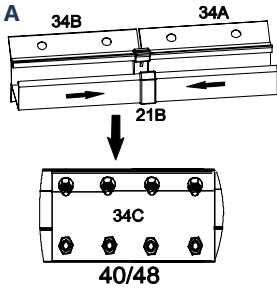

Fissaggio della parte 10 alla parte 32A

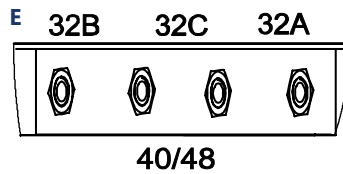
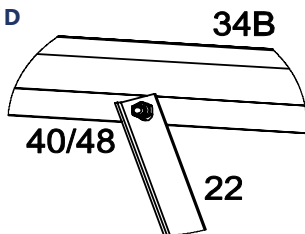

## MONTAGGIO DELLA PARETE DESTRA (vista dalla porta)

N.	Figura	Quantità	Dimensioni (mm)
10		2	1215
22		2	1304
22A		1	1362
21B		1	
32A		1	1432
32B		1	996
32C		1	170

N.	Figura	Quantità	Dimensioni (mm)
34A		1	1433
34B		1	390
34C		1	170
40		18	M6x10
48		18	M6

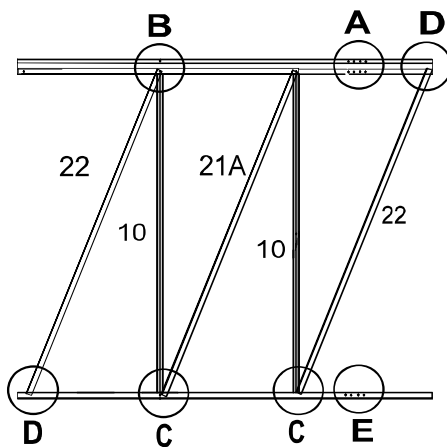
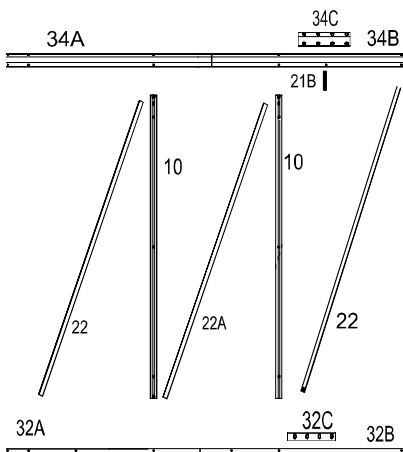

Montare prima le figure A ed E.

Inserire il raccordo 21B tra 34A/34B in direzione della freccia e fissarlo con 34C utilizzando viti e dadi.

Prima di collegare le parti 32 e 34 alle parti 10, 21A e 22, serrare le viti.

Parete laterale vista dall'interno.

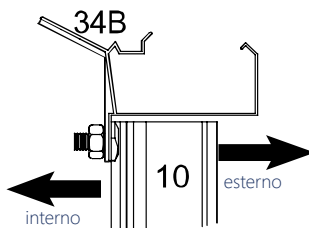
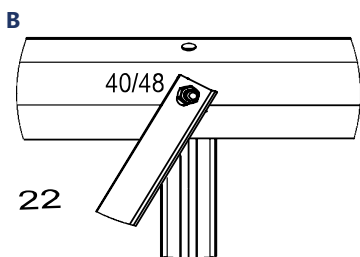
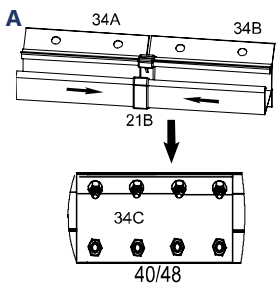

Vista dettagliata

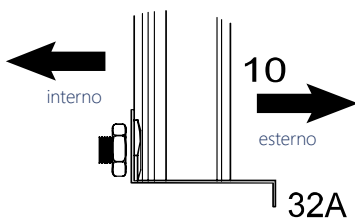
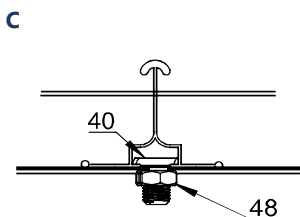

Fissaggio della parte 10 alla parte 32A

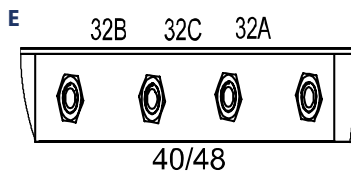
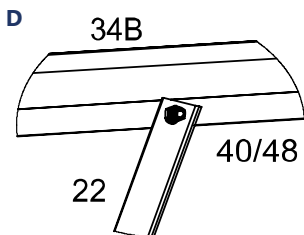

## MONTAGGIO DEL TELAIO DELLA PARETE POSTERIORE

N.	Figura	Quantità	Dimensioni (mm)
1		2	1215
4		1	1134
5		1	1134
8		1	1655
9		1	1655
13		2	

N.	Figura	Quantità	Dimensioni (mm)
16		2	911
16A		1	170
21		2	1220
21A		2	610
40		24	M6x10
48		24	M6

Parete posteriore vista dall'interno

Le viti sono fissate dall'interno con i dadi

Serrare le viti e i dadi relativi alle viste C ed E

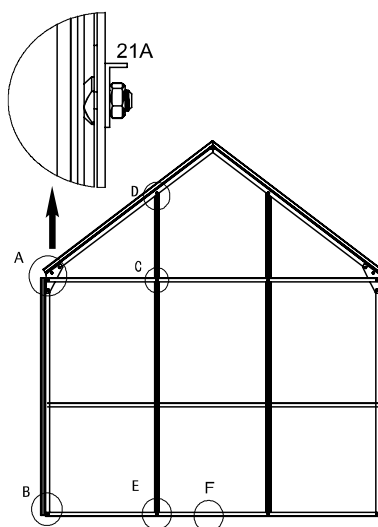
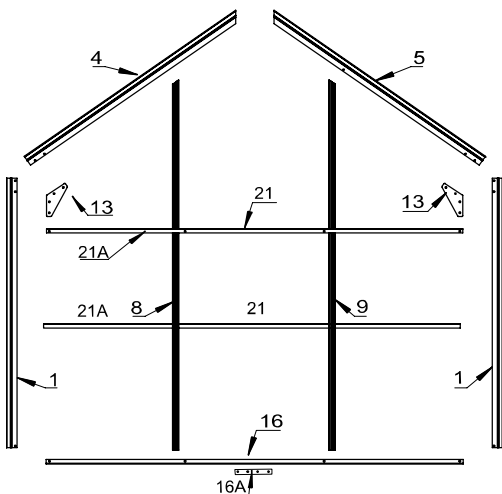

**A**

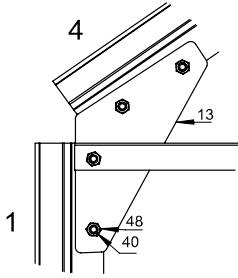

**B**

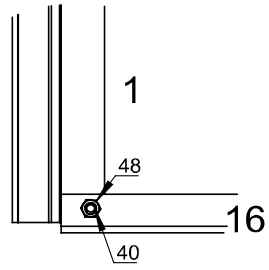

**C**

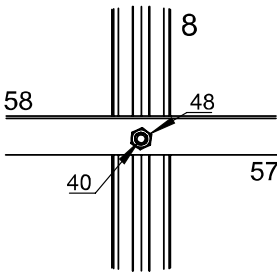

**D**

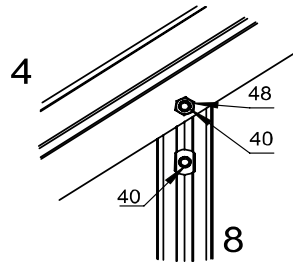

**E**

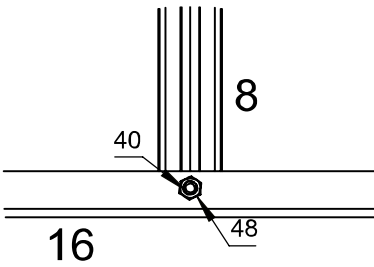



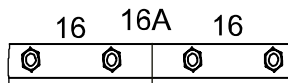
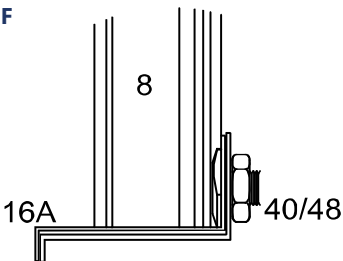

**F**

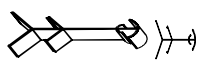
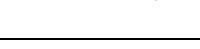

Vista dettagliata

## COLLEGAMENTO DEI TELAI DELLE PARETI

N.	Figura	Quantità	Dimensioni (mm)
33		1	1433
33A		1	388
33C		1	170

N.	Figura	Quantità	Dimensioni (mm)
40		24	M6x10
48		24	M6

Per collegare gli elementi dei telai sono necessarie almeno 2 o 3 persone.

Prestare attenzione alla disposizione dei profili di alluminio sottostanti e all'utilizzo di viti per il fissaggio.



Dopo aver terminato l'assemblaggio dei telai delle pareti, assemblare il colmo del tetto parte 33.

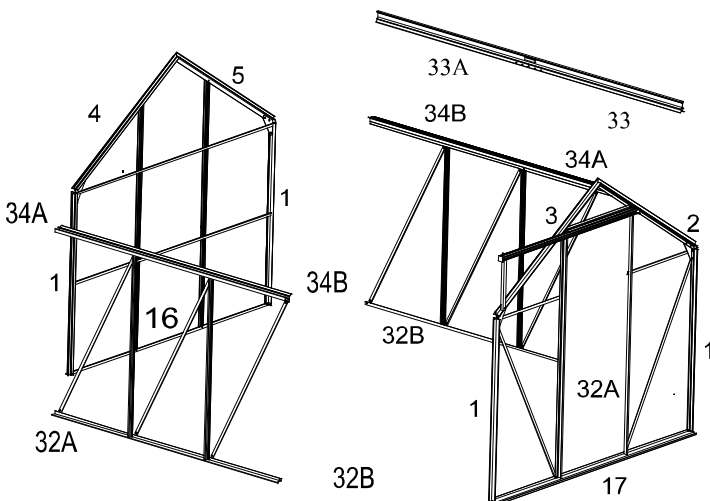
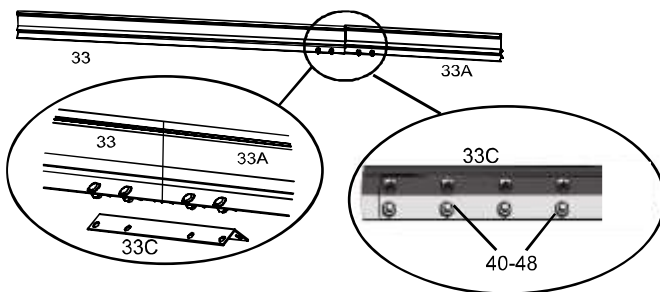

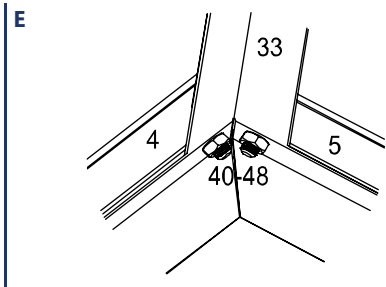
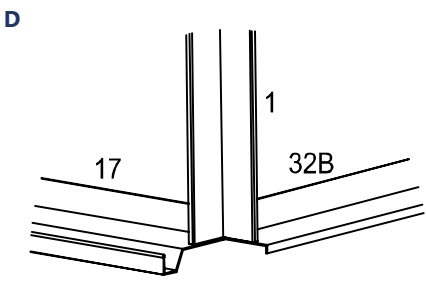
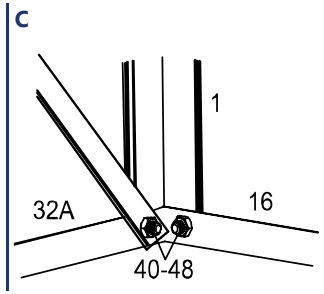
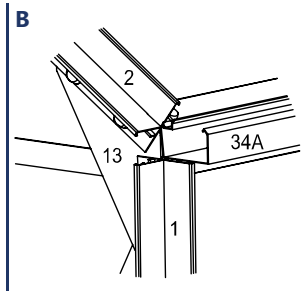
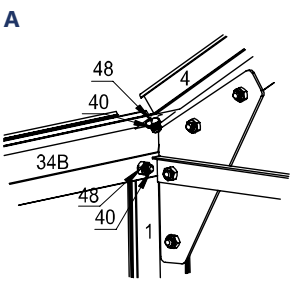
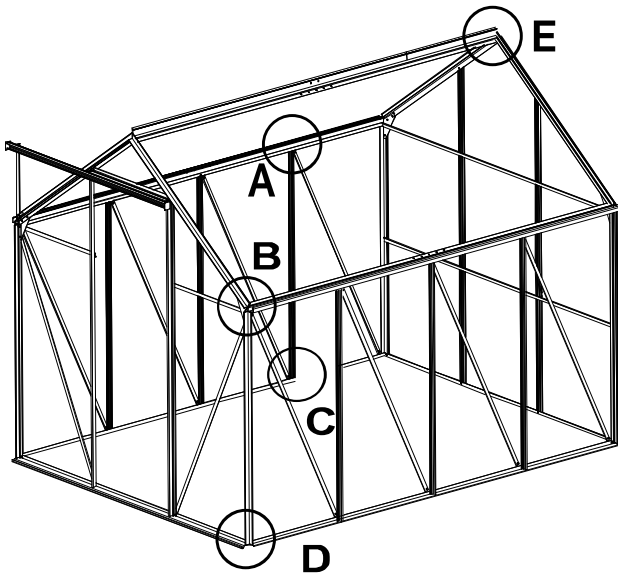

È possibile garantire la stabilità completa della serra dopo aver serrato tutte le viti del telaio in alluminio e aver montato i pannelli.

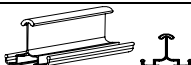
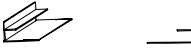
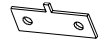
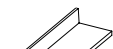



## MONTAGGIO DEL TELAIO DEL TETTO

N.	Figura	Quantità	Dimensioni (mm)
11		4	1114
15		1	634
18		2	
21		2	1220
21A		2	610





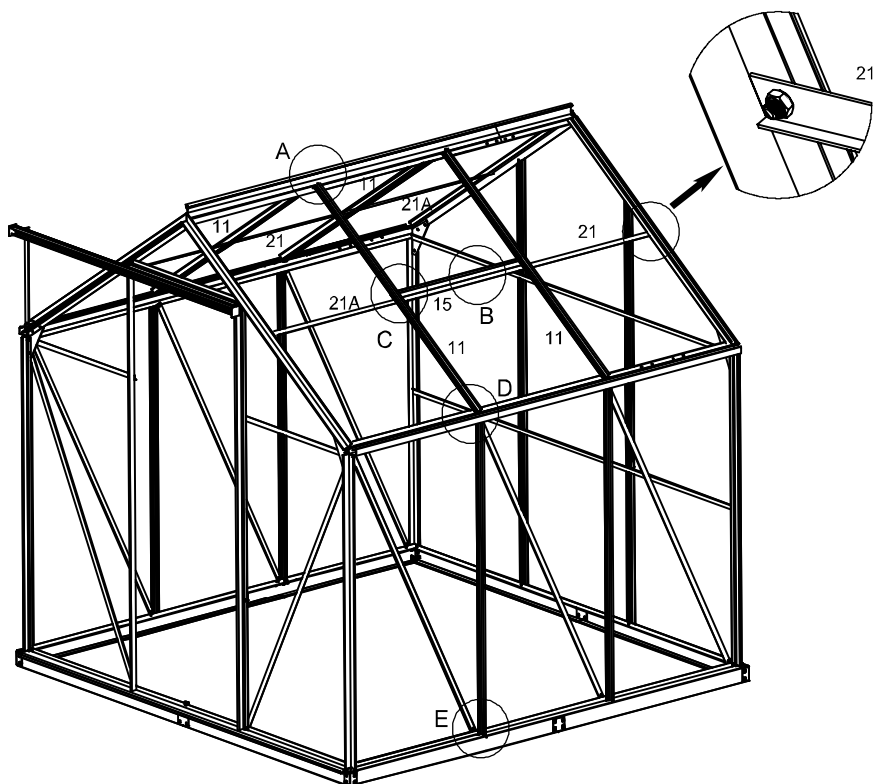

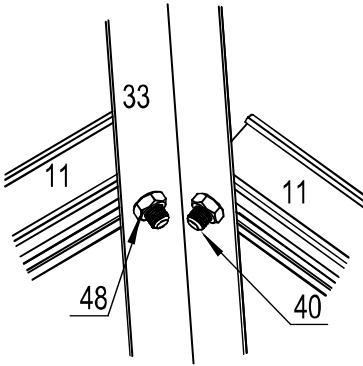
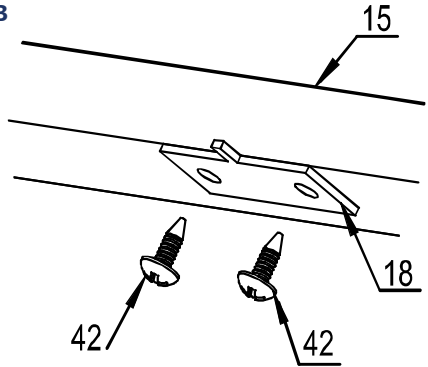
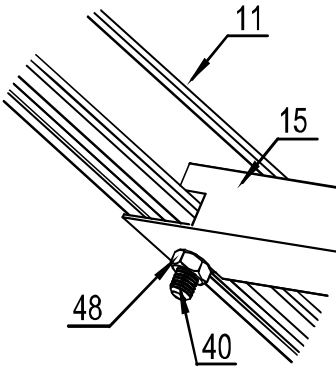
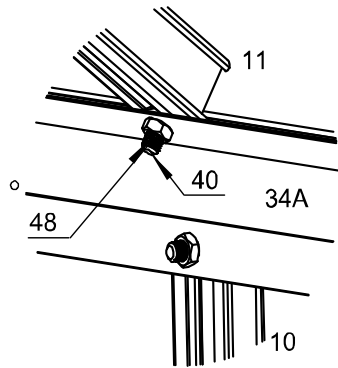
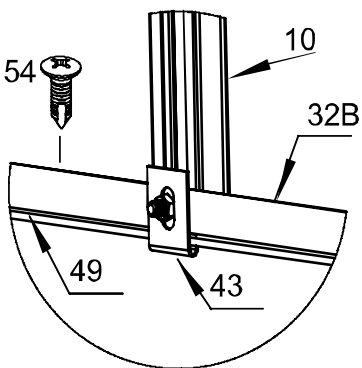
N.	Figura	Quantità	Dimensioni (mm)
40		18	M6x10
42		4	M4x18
43		16	
48		18	M6
54		16	







La parte 43 serve per collegare il pavimento della serra alla fondazione.



**A****B****C****D****E**

## FISSAGGIO DEI PANNELLI TRASPARENTI IN POLICARBONATO

N.	Figura	Quantità	Dimensioni (mm)
1		11	605 x 1212
2		5	605 x 1130
3A		2	605 x 455
3B		2	605 x 455
4		1	605 x 585
5		1	595 x 550
6		1	605 x 675

N.	Figura	Quantità	Dimensioni (mm)
7		1	605 x 250
8		1	615 x 241
9		2	605 x 602
35		5	
47		162	
53		44	

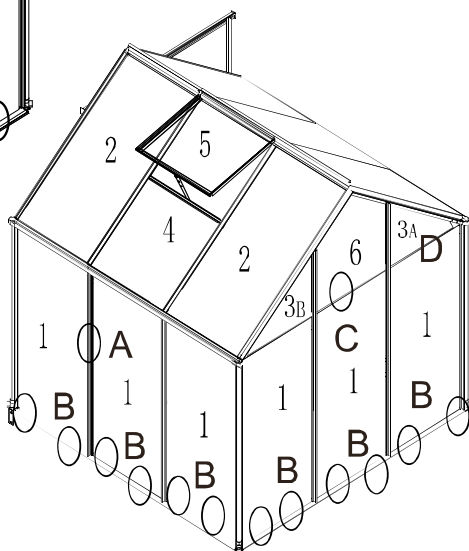
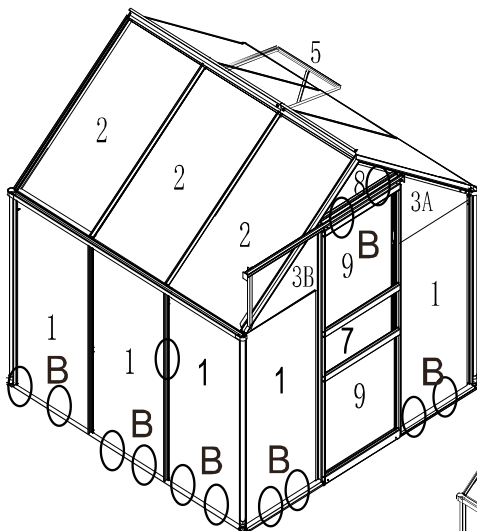

A



B

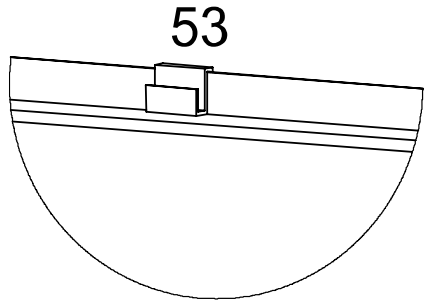

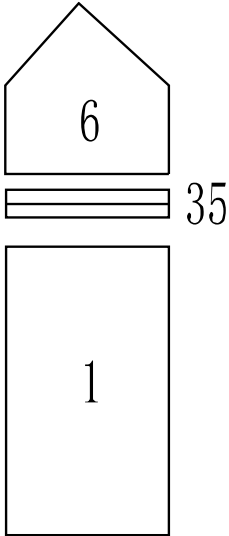

C



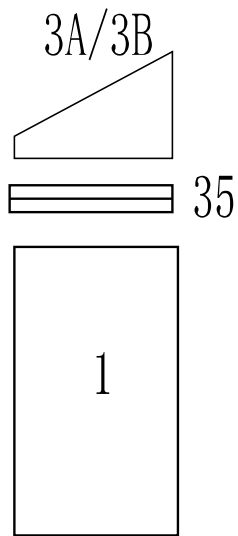

D



## MONTAGGIO DELLA PORTA SCORREVOLE E DELLA GRONDAIA

N.	Figura	Quantità	Dimensioni (mm)
44A		2	
44B		2	
45A		1	

N.	Figura	Quantità	Dimensioni (mm)
45B		1	
40		2	M6x10
48		2	M6

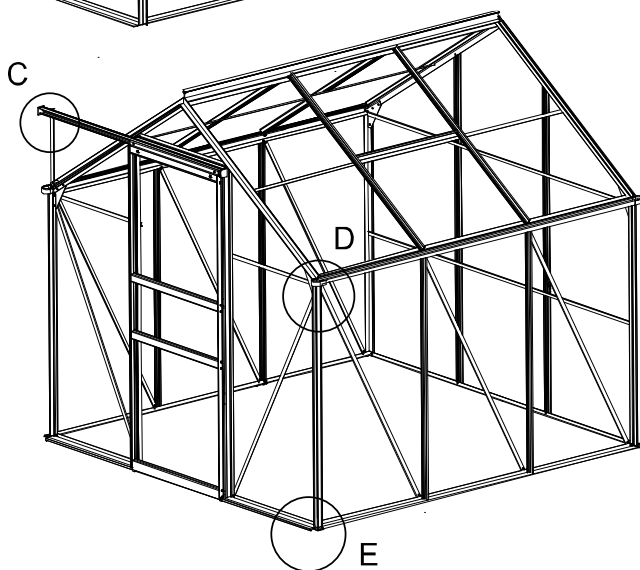
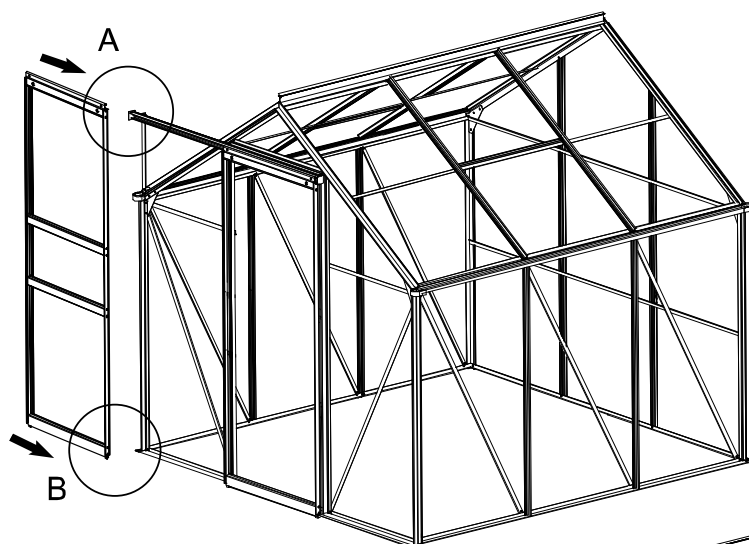

A

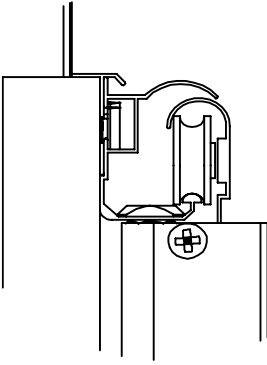

B

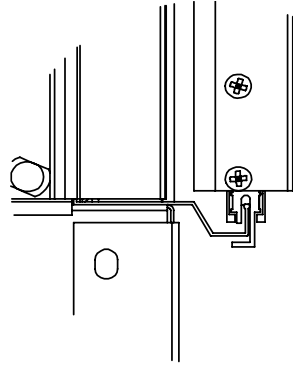

C

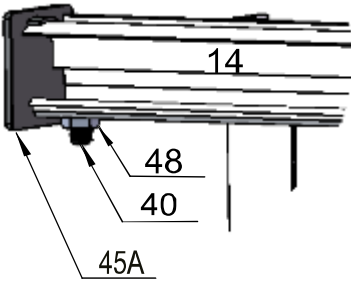

D

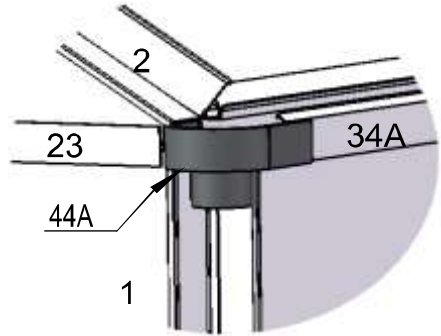

E

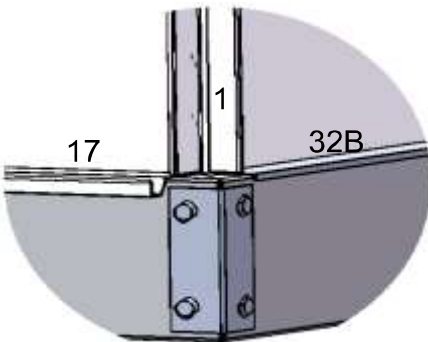

# MANUAL DE INSTRUCCIONES

## Apreciada clienta, apreciado cliente:

Muchas gracias por elegir nuestro producto. Sin duda, ha hecho una buena elección al comprar uno de nuestros productos de marca. Para cumplir el alto nivel de calidad deseado, nuestros artículos se someten a controles periódicos y, lógicamente, siempre cumplen con las máximas de la Unión Europea.

## ÍNDICE

SÍMBOLOS.....	108
INDICACIONES GENERALES.....	109
USO PREVISTO .....	109
INDICACIONES PARA EL DESEMBALAJE.....	109
SELECCIÓN DEL LUGAR DE COLOCACIÓN.....	109
INDICACIONES DE MONTAJE .....	110
INSTRUCCIONES DE MANTENIMIENTO Y CUIDADO .....	110
ELIMINACIÓN.....	111
LISTA DE PIEZAS .....	112
LISTA DE PIEZAS PANELES PC.....	114
MONTAJE DE LA VENTANA DEL TECHO.....	115
MONTAJE DEL MARCO DE LA PUERTA CORREDERA .....	117
MONTAJE DEL MARCO DELANTERO.....	119
MONTAJE PARED IZQUIERDA.....	121
MONTAJE PARED DERECHA.....	123
MONTAJE DEL MARCO PARED TRASERA .....	125
CONECTAR LOS MARCOS DE LAS PAREDES .....	127
MONTAJE DEL MARCO DEL TEJADO.....	129
FIJACIÓN DE LOS PANELES DE PC TRANSPARENTES .....	131
INSTALACIÓN DE PUERTA CORREDERA Y VIERTEAGUAS.....	133

## SÍMBOLOS



### LEA ESTAS INSTRUCCIONES DETENIDAMENTE. INFORMACIÓN IMPORTANTE. ¡CONSERVELAS PARA FUTURAS CONSULTAS!

Antes de usar el producto por primera vez, lea atentamente las instrucciones. Consérvelas para poder consultarlo en un futuro. En caso de que en algún momento entregara este producto a un tercero, no olvide entregarle también las instrucciones.



### ¡ATENCIÓN! ¡RIESGO POTENCIAL!

Siga las indicaciones de seguridad y las instrucciones de montaje para reducir el riesgo de lesiones o daños en el producto.



### ¡RIESGO DE ASFIXIA!

¡Mantenga las piezas pequeñas y los materiales de embalaje fuera del alcance de los niños!



### MODIFICACIONES DEL PRODUCTO

¡No haga modificaciones en este producto bajo ningún pretexto! Cualquier modificación anulará la garantía y podría hacer que el producto se vuelva inseguro o, en el peor de los casos, incluso peligroso.

## INDICACIONES GENERALES

- Recomendamos un mínimo de 2 personas para el montaje.
- Elija una ubicación con espacio suficiente alrededor de la caseta para trabajar.
- Siga los pasos de las instrucciones para garantizar un montaje correcto y seguro.
- Antes de empezar con el montaje, asegúrese de que están todas las piezas.
- Compruebe que el bastidor esté colocado de una forma plana en el suelo.
- La base tiene que estar nivelada. Si el suelo es irregular, nivélelo.
- Es importante anclar el invernadero firmemente a la base para evitar daños por viento fuerte.
- **¡ATENCIÓN!** ¡No se suba al tejado! ¡Peligro de derrumbamiento!
- Si el fundamento que va a utilizar no es de hormigón fundido, debe asegurarse de que la superficie es firme y esté nivelada. ¡El producto debe fijarse con/dentro de un fundamento! El invernadero sólo se mantendrá de manera estable y duradera si está perfectamente alineado. Incluso con paredes ligeramente inclinadas, éstas pueden no quedar fijadas correctamente en las guías previstas y el viento podría levantarlas fácilmente de sus goznes.
- El fundamento del invernadero tiene que estar anclado/fijado en cualquier caso en el suelo. La superficie del invernadero es grande y representa también una superficie grande de ataque para el viento, que puede causar lesiones y/o daños materiales.
- ¡No haga nunca un fuego en el invernadero y manténgalo alejado de llamas y chispas!
- No utilice este producto si faltan piezas o si estas están dañadas o desgastadas.
- ¡Preste atención a no encerrar personas y/o animales en el invernadero!
- Evite en la medida de lo posible la presencia de ramas sobresalientes de los árboles, ya que la caída de las hojas exige una limpieza periódica y la rotura de ramas son una fuente de peligro.
- Los árboles pequeños, arbustos o las vallas cercanas pueden ser útiles como cortavientos.
- **¡ADVERTENCIA!** Si hace viento y tormenta debe cerrar las puertas y ventanas.

## USO PREVISTO

El invernadero está diseñado para cultivar hortalizas, flores y otras plantas. La caseta no está indicada para almacenar sustancias peligrosas, ni para alojar personas o animales. El producto debe emplearse únicamente para su fin previsto. El fabricante no asume ningún tipo de responsabilidad en caso de daños ocasionados por el uso inadecuado del producto. Cualquier modificación realizada en el producto puede ser perjudicial para la seguridad u ocasionar riesgos y anulará la garantía.

**Solo para uso doméstico y no comercial.**

## INDICACIONES PARA EL DESEMBALAJE

Abra la caja y extraiga las piezas y elementos del set y coloque los componentes en la parte superior de la caja o en otra superficie limpia. Así protegerá su producto nuevo. Asegúrese de que el producto no presente daños y esté completo después de desembalarlo. No se aceptarán reclamaciones posteriores.

## SELECCIÓN DEL LUGAR DE COLOCACIÓN

Familiarícese con las normativas y ordenanzas locales, antes de iniciar el montaje. ¡A la hora de elegir un lugar adecuado para instalar el invernadero, asegúrese de que el suelo sea estable y llano, y no elija un lugar expuesto en el que la caseta quede completamente libre! Debe

asegurarse de que haya un grado de protección contra las tormentas y las ráfagas de viento. De lo contrario, se producirá un daño independiente.

## **INDICACIONES DE MONTAJE**

Siga los pasos indicados en gráficos de las instrucciones para el montaje.



Utilice durante el montaje siempre guantes de seguridad, mangas largas y protección para los ojos. ¡Algunas piezas podrían presentar bordes afilados y causar lesiones!

Escanee el código QR para  
acceder al vídeo de montaje.

- Antes de montar el invernadero, es importante que se haya preparado un fundamento adecuado. En nuestra tienda en línea puede adquirir fundamentos ("elementos auxiliares de encofrado") de este tipo.
- No monte el invernadero si hace viento o llueve.
- Extraiga las piezas de la caja y ordénelas por número. Asegúrese de que tiene todas las piezas necesarias para el montaje.
- Familiarícese con el funcionamiento de todas las herramientas.
- Mantenga a los niños y a los animales domésticos alejados del lugar de instalación.
- Si utiliza una escalera, asegúrese de que está bien anclada. No apoye nunca todo el peso en ninguna parte del tejado o del invernadero.
- Para algunos pasos del montaje se requieren dos personas.
- Guarde las piezas pequeñas (tornillos, etc.) en las cajas y bolsas para que no se pierdan.
- Cada pieza está numerada. Encontrará el número correspondiente en las instrucciones de montaje.
- Inicie el montaje colocando las piezas con el mismo número en grupos separados en torno al lugar de instalación.
- En primer lugar deberá montar el marco de aluminio del invernadero y en último lugar los paneles de PC.

## **INSTRUCCIONES DE MANTENIMIENTO Y CUIDADO**

- Para la limpieza, utilice una esponja y agua tibia. No utilice productos o agentes de limpieza que contengan disolventes, como, por ejemplo, lejía, dado que pueden dañar el producto.
- Utilice siempre las herramientas adecuadas para los trabajos en el invernadero.
- ¡Sustituya las piezas dañadas del invernadero inmediatamente! ¡Las partes dañadas pueden dañar a las personas y animales!
- Preste atención en invierno, en la medida de lo posible, a que el tejado se mantenga sin nieve. Si la capa de nieve es demasiado gruesa, puede derrumbarse. Un grosor de nieve de más de 10 cm ya puede ser peligroso (alturas de capa de 36 cm para nieve seca, 10 cm para nieve acuosa y 5,5 cm para hielo corresponden a un peso de aprox. 50 kg/m<sup>2</sup>).
- Si surgen problemas imprevistos, póngase en contacto con nuestro equipo de servicio. Estaremos encantados de ayudarle.











## **ELIMINACIÓN**



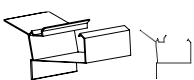
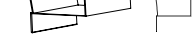



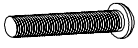
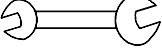



Al final de la larga vida útil de este producto, deseche las materias primas valiosas de una manera adecuada para que se puedan reciclar según corresponda. En caso de duda sobre la mejor manera de proceder, consulte a las empresas de gestión de residuos o a los centros de reciclaje locales.

## LISTA DE PIEZAS (caja 1/2)





N.º	Imagen	Canti- dad	Medi- das (mm)
1		4	1215
2		1	1134
3		1	1134
4		1	1134
5		1	1134
6		1	1647
7		1	1647
8		1	1655
9		1	1655
10		4	1215
11		4	1114
12		1	610
13		4	
14		1	1260
15		1	634
16		2	911
16A		1	170
17		1	1355
17A		1	467
17B		1	170





N.º	Imagen	Canti- dad	Medi- das (mm)
18		2	
19		1	380
20		2	1608
21		4	1220
21A		4	610
21B		2	
22		4	1350
22A		2	1362
23		2	594
24		1	610
25		2	1304
26		2	610
27		1	610
28		2	520
29		1	608
30		1	595
31		1	595
32A		2	1432
32B		2	390
32C		2	170

N.º	Imagen	Canti- dad	Medi- das (mm)
33		1	1433
33A		1	388
33C		1	170
34A		2	1433
34B		2	390
34C		2	170
35		5	603
36		2	
37		1	
38		1	M5x30
39		2	
40		138	M6x10

N.º	Imagen	Canti- dad	Medi- das (mm)
41		14	M5x18
41A		2	M4x18
42		6	M4x8
44A		2	
44B		2	
45A		1	
45B		1	
46		1	
47		162	
48		137	M6
53		44	

## LISTA DE PIEZAS PANELES PC (caja 2/2)

N.º	Imagen	Canti- dad	Medidas (mm)
1		11	605 x 1212
2		5	605 x 1130
3A		2	605 x 455
3B		2	605 x 455
4		1	605 x 585

N.º	Imagen	Canti- dad	Medidas (mm)
5		1	595 x 550
6		1	605 x 675
7		1	605 x 250
8		1	615 x 241
9		2	605 x 602

## INSTRUCCIONES PARA EL MONTAJE DE LOS PANELES PC



Foto de los paneles de PC de 4 mm

Los paneles tienen una cara con una película protectora blanca sin protección UV y una cara con una película protectora verde con protección UV. La cara verde debe instalarse en el exterior.

La película protege los paneles, por lo que recomendamos que no retire la película protectora antes de insertar los paneles en el marco del invernadero, para saber cuál es el lado con protección UV y no confundir los lados durante el montaje.

Una buena opción es retirar unos 5 cm de la película protectora de todos los bordes del panel antes de montarlo en el marco de aluminio (para que no quede debajo de los tornillos y las tiras de aluminio), y cuando haya fijado el panel en el marco, podrá retirar la película protectora por completo.

Trate los paneles con esmero para que no se rayen durante el montaje.

Le recomendamos tener preparadas las siguientes herramientas para el montaje:

- Guantes de protección
- Cinta métrica
- Destornillador plano
- Destornillador eléctrico

(El embalaje contiene una llave inglesa).

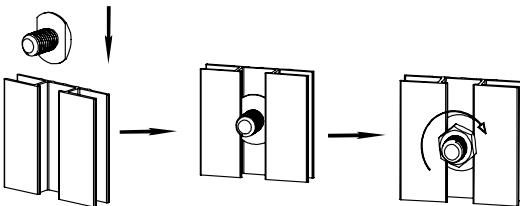

Así introduce los tornillos en las ranuras de los listones de aluminio.

## MONTAJE DE LA VENTANA DEL TECHO

Coloque las piezas como se muestra a continuación, inserte los tornillos (n° 40) de arriba a abajo, monte primero las piezas 28 y 31, después la placa (pieza 5) y en el siguiente paso la pieza 30.

N.º	Imagen	Canti- dad	Medidas (mm)
28		2	520
30		1	595
31		1	595
40		4	M6x10

N.º	Imagen	Canti- dad	Medidas (mm)
42		2	M4x8
46		1	
48		4	M6
5		1	595 x 550

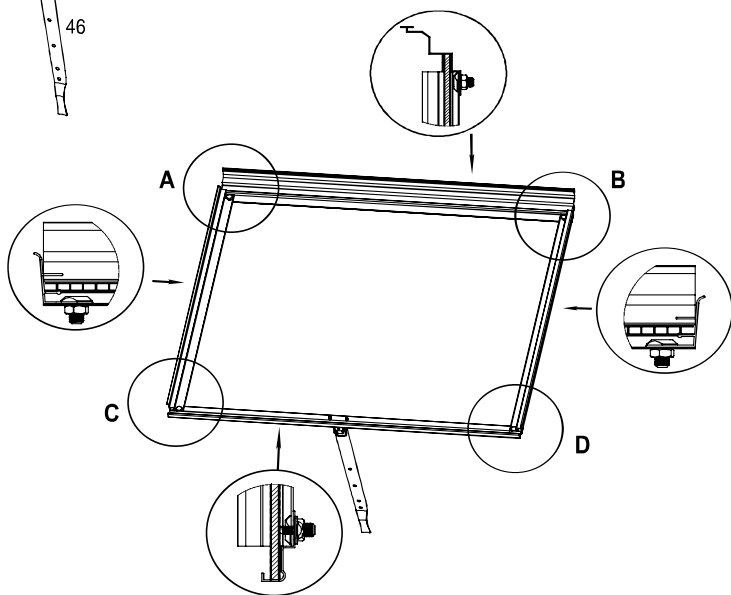
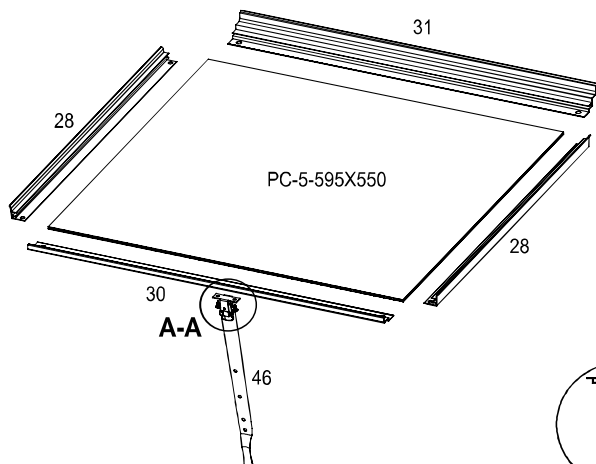

La cara verde de la película protectora con protección UV debe estar orientada hacia el sol. La cara blanca de la película protectora sin protección UV debe estar orientada hacia el interior del invernadero.

**AA**

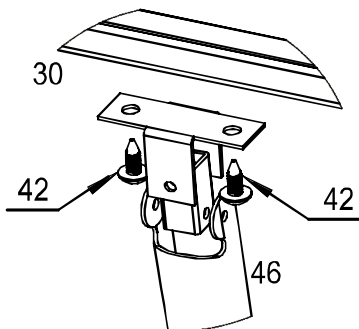

**A**

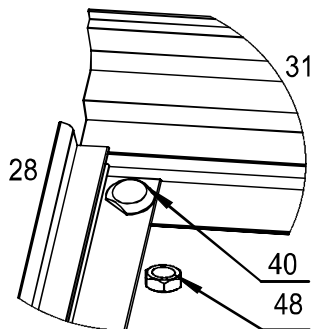

Fije el soporte en los orificios para tornillos previstos.

**B**

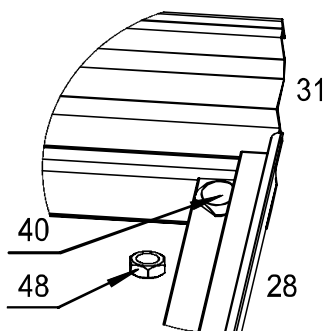

**C**

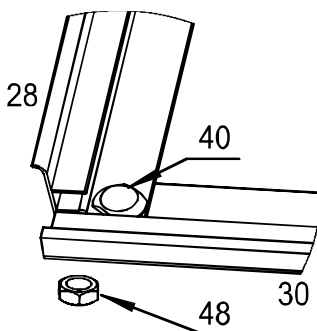





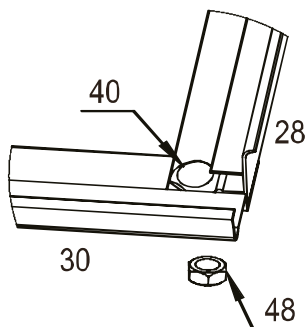

Apriete el tornillo y la tuerca después de insertar la pieza 30 en la posición del tornillo.

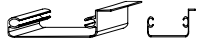
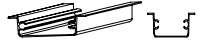
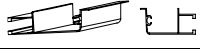
**D**



## MONTAJE DEL MARCO DE LA PUERTA CORREDERA

N.º	Imagen	Canti- dad	Medi- das (mm)
20		2	1608
24		1	610
26		2	610
27		1	610
29		1	608

N.º	Imagen	Canti- dad	Medi- das (mm)
36		2	
40		2	M6x10
41		14	M5x18
41A		2	M4x18
48		2	M4x8

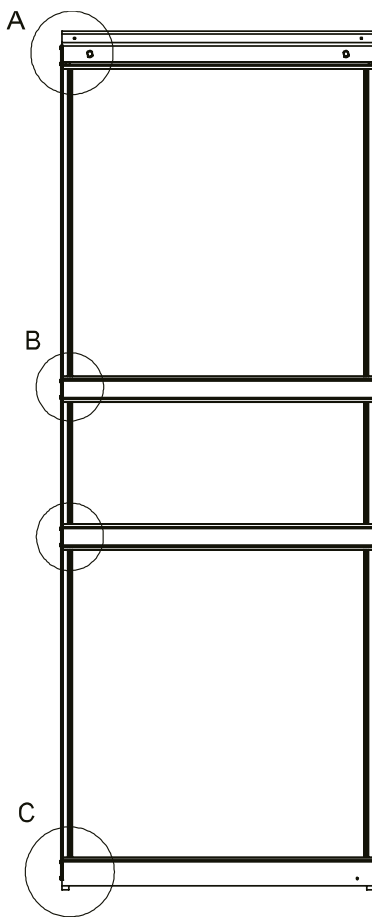
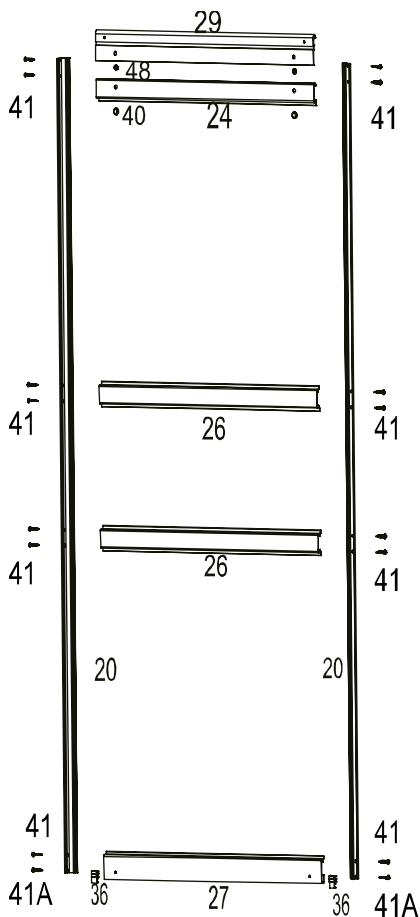

A

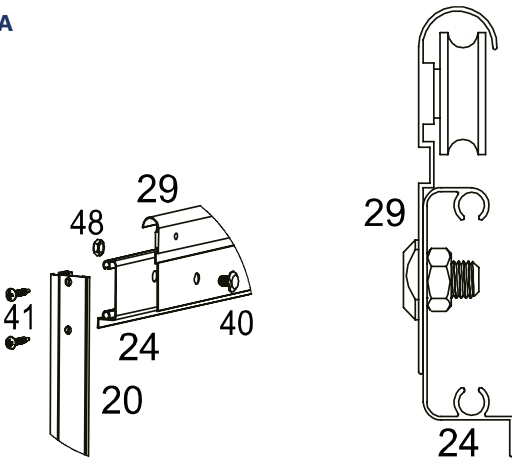

B

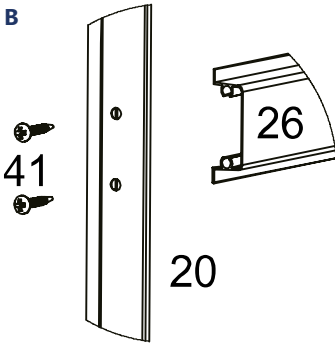

C

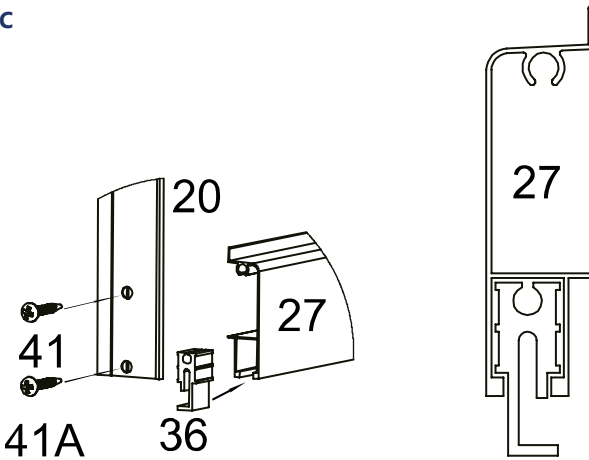

## MONTAJE DEL MARCO DELANTERO

N.º	Imagen	Canti- dad	Medi- das (mm)
1		2	1215
2		1	1134
3		1	1134
6		1	1647
7		1	1647
12		1	610
13		2	
14		1	1260
17		1	1335
17A		1	467

N.º	Imagen	Canti- dad	Medi- das (mm)
17B		1	170
19		1	380
23		2	594
25		2	1304
37		1	
38		1	
40		26	M6x10
48		27	M6

Siga las instrucciones de montaje relativas a las partes 2 y 3 para la construcción.  
Marco frontal visto desde el interior del invernadero (vistas inferiores).

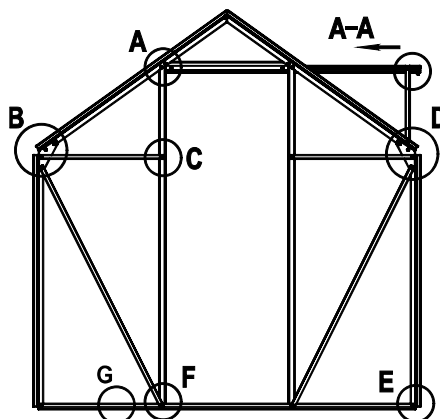
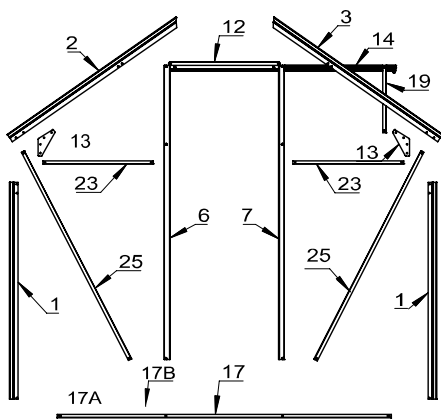

Visto desde el exterior del invernadero.

**AA**



Imagen tras la instalación de la pieza nº 14.

**A**

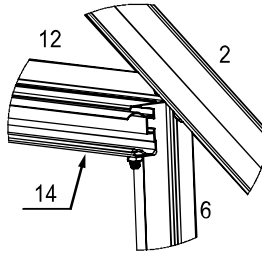
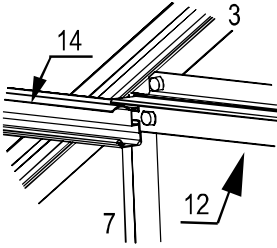
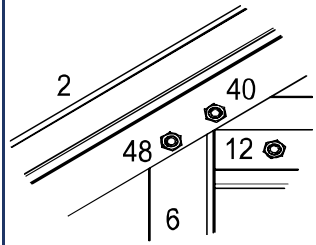

La sección A muestra el interior, tenga en cuenta las instrucciones de instalación de las piezas 40 y 48.

**B**

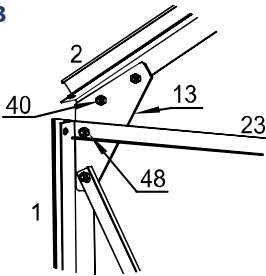

**C**

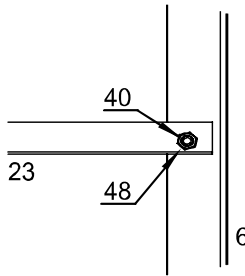

**D**

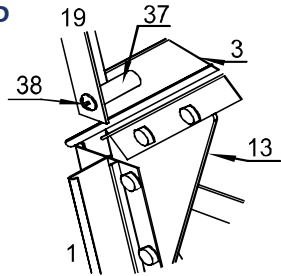

**E**

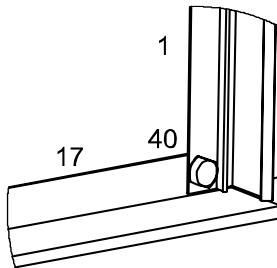

**F**

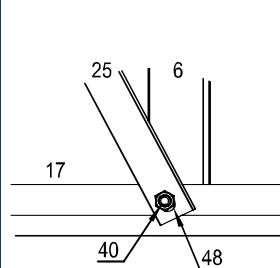



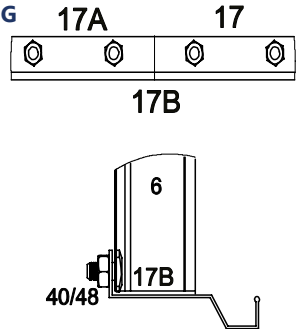





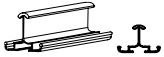
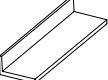

**G**

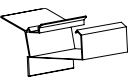

Vista detallada

## MONTAJE PARED IZQUIERDA (visto desde la puerta)

N.º	Imagen	Canti- dad	Medi- das (mm)
10		2	1215
22		2	1304
22A		1	1362
21B		1	
32A		1	1432
32B		1	390
32C		1	170

N.º	Imagen	Canti- dad	Medi- das (mm)
34A		1	1433
34B		1	390
34C		1	170
40		18	M6x10
48		18	M6

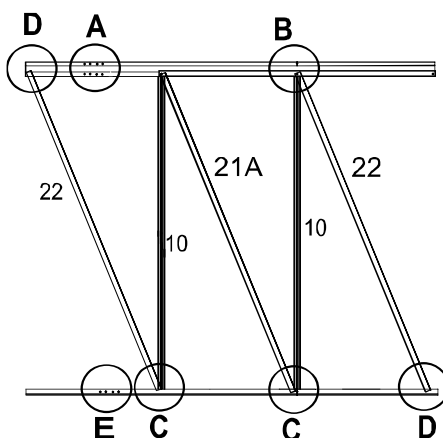
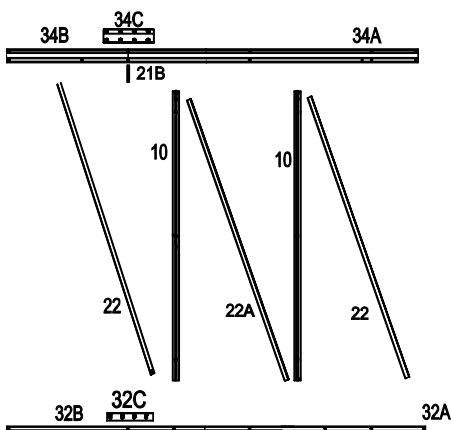

Monte primero lo que figura en la ilustración A y E.

Introduzca el herraje 21B entre 34A/34B en la dirección de la flecha y fíjelo con 34C utilizando tuercas y tornillos.

Apriete primero los tornillos antes de unir las piezas 32 y 34 con las 'piezas 10, 21A y 22.

Pared lateral visto desde el interior.

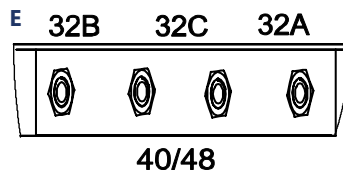
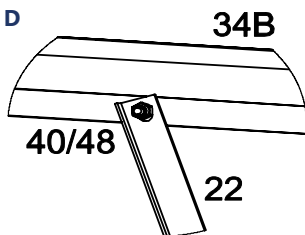
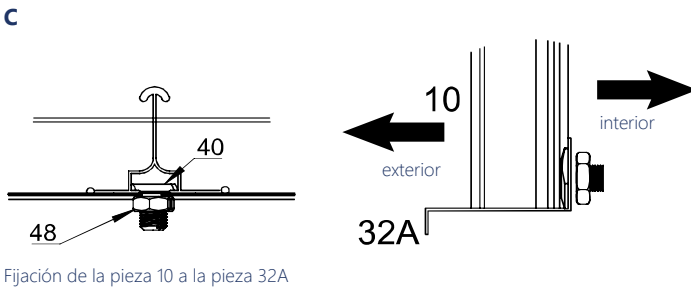
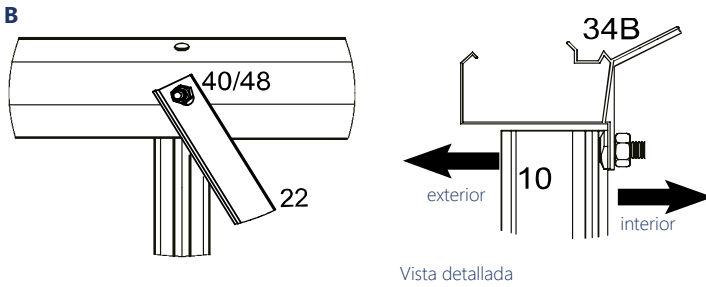
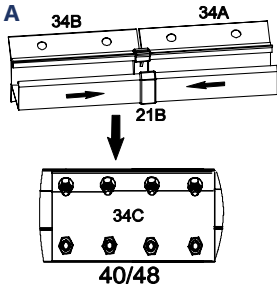

## MONTAJE PARED DERECHA (visto desde la puerta)

N.º	Imagen	Canti- dad	Medi- das (mm)
10		2	1215
22		2	1304
22A		1	1362
21B		1	
32A		1	1432
32B		1	996
32C		1	170

N.º	Imagen	Canti- dad	Medi- das (mm)
34A		1	1433
34B		1	390
34C		1	170
40		18	M6x10
48		18	M6

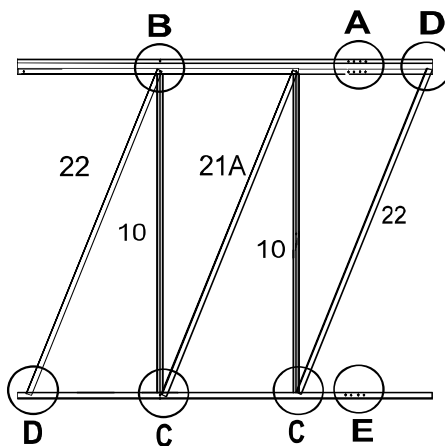
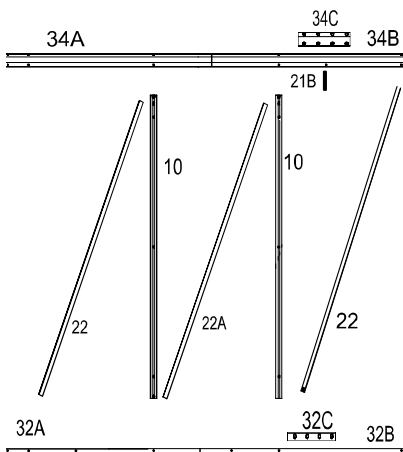

Montar primero lo que figura en la ilustración A y E.

Introduzca el herraje 21B entre 34A/34B en la dirección de la flecha y fíjelo con 34C utilizando tuercas y tornillos.

Apretar primero los tornillos antes de unir las piezas 32 y 34 con las piezas 10, 21A y 22.

Pared lateral visto desde el interior.

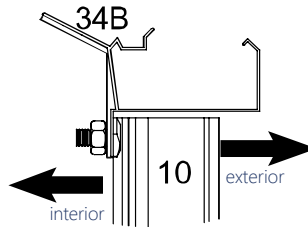
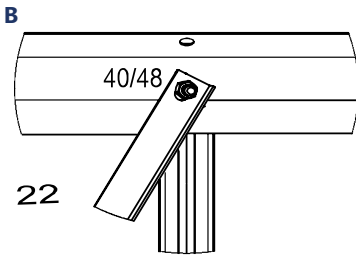
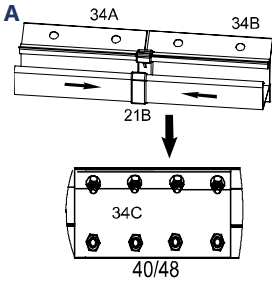

Vista detallada

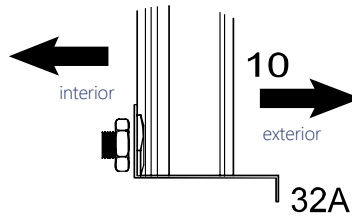
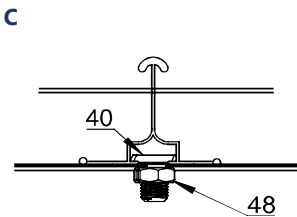

Fijación de la pieza 10 a la pieza 32A

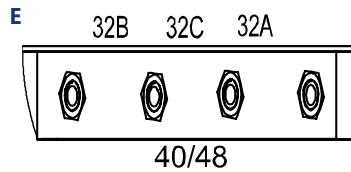
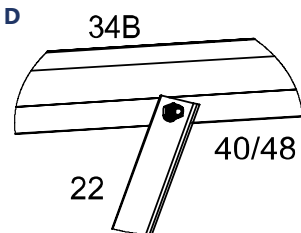

## MONTAJE DEL MARCO PARED TRASERA

N.º	Imagen	Canti- dad	Medi- das (mm)
1		2	1215
4		1	1134
5		1	1134
8		1	1655
9		1	1655
13		2	

N.º	Imagen	Canti- dad	Medi- das (mm)
16		2	911
16A		1	170
21		2	1220
21A		2	610
40		24	M6x10
48		24	M6

Pared trasera vista desde el interior

Los tornillos se fijan con tuercas desde el interior

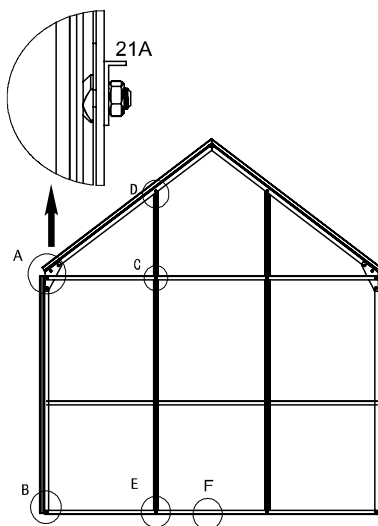
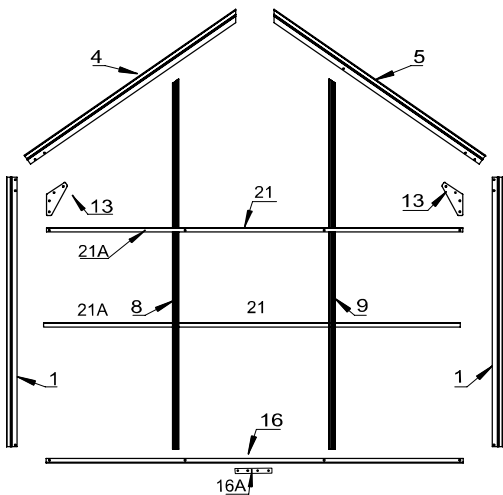

Apriete los tornillos y las tuercas para las vistas C y E

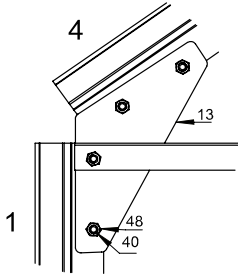
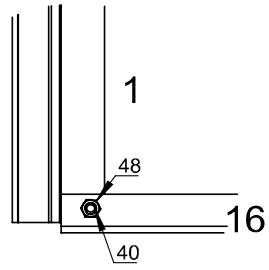
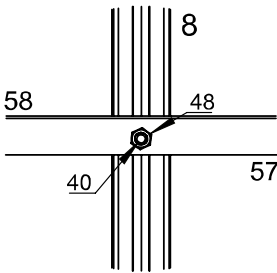
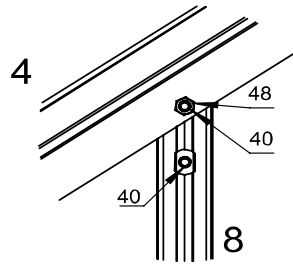
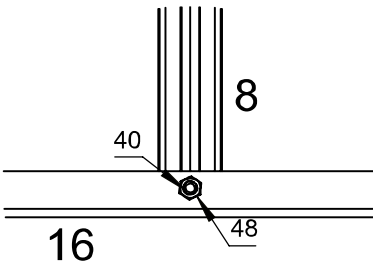
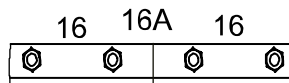
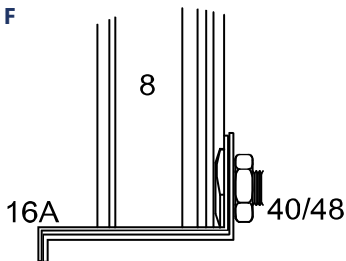

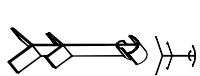
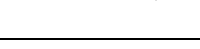

**A****B****C****D****E****F**

Vista detallada

## CONECTAR LOS MARCOS DE LAS PAREDES

N.º	Imagen	Canti- dad	Medi- das (mm)
33		1	1433
33A		1	388
33C		1	170

N.º	Imagen	Canti- dad	Medi- das (mm)
40		24	M6x10
48		24	M6

Para unir los elementos del marco se necesitan al menos de 2 a 3 personas.

Tenga en cuenta la disposición de los perfiles de aluminio y el uso de tornillos para la fijación como se muestra a continuación.

Cuando haya terminado de montar los marcos de las paredes, monte la parte 33 de la cumbrera del tejado.

La estabilidad final del invernadero se consigue después de haber apretado todos los tornillos de los marcos de aluminio y montado los paneles.

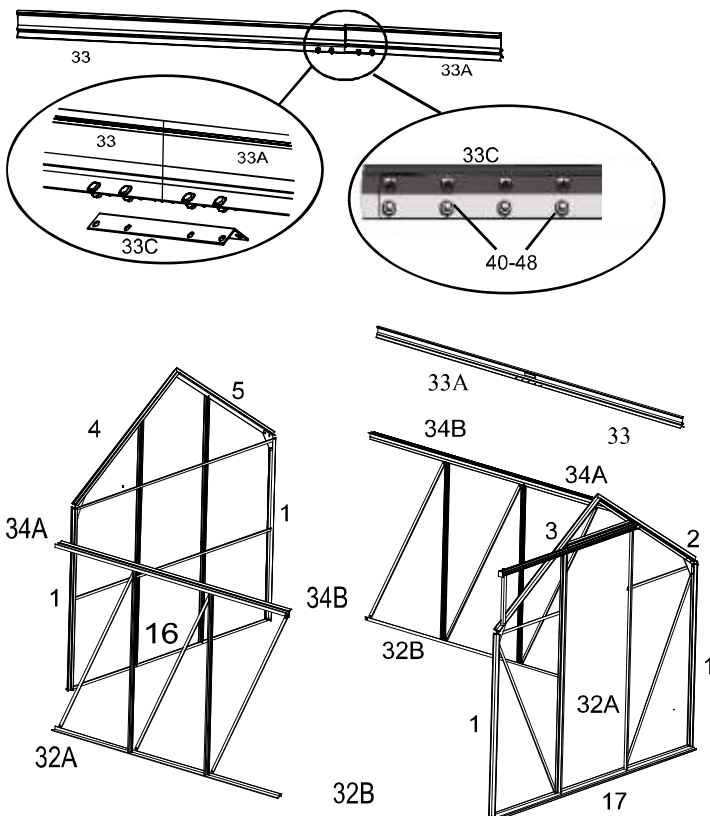

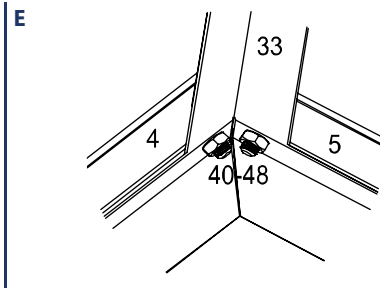
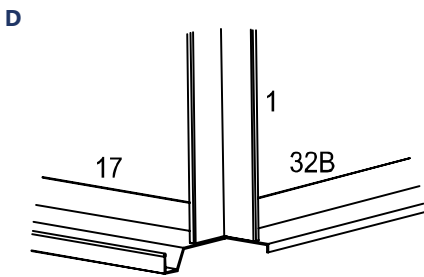
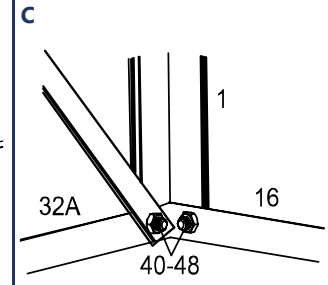
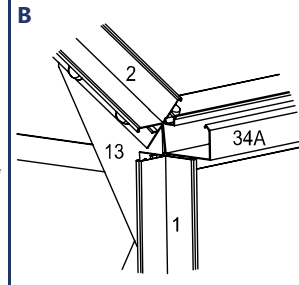
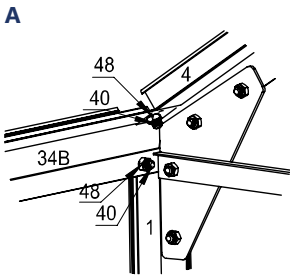
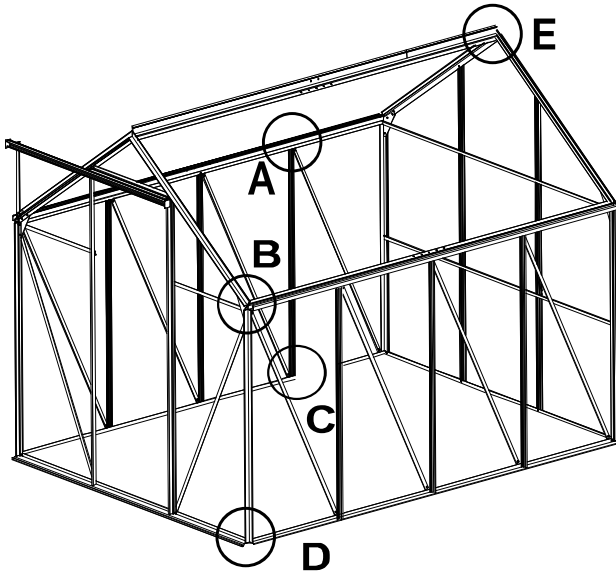

## MONTAJE DEL MARCO DEL TEJADO

N.º	Imagen	Canti- dad	Medi- das (mm)
11		4	1114
15		1	634
18		2	
21		2	1220
21A		2	610





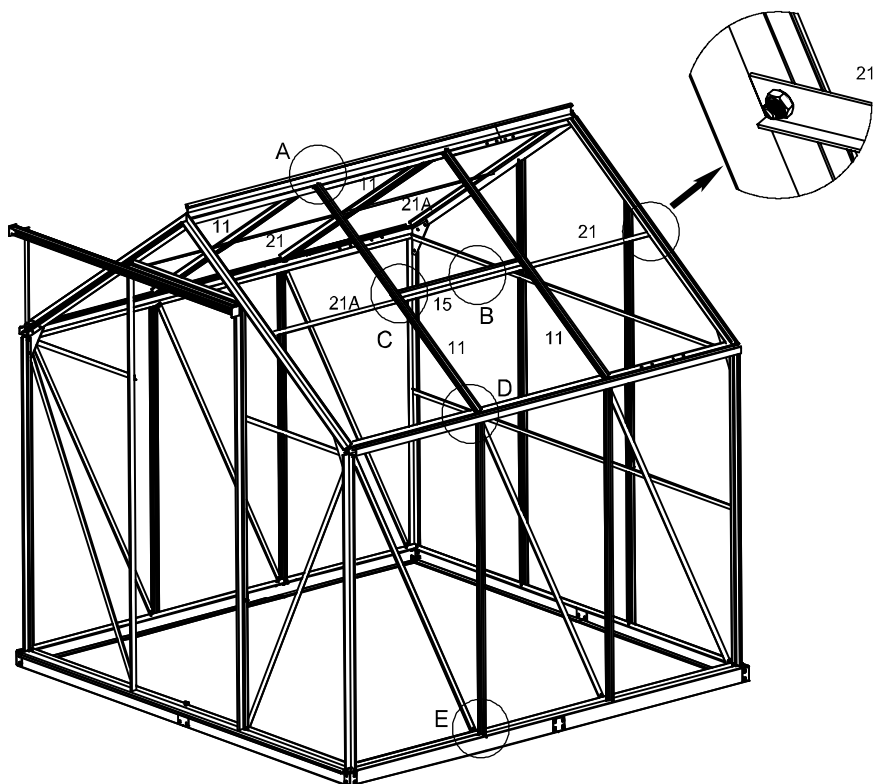

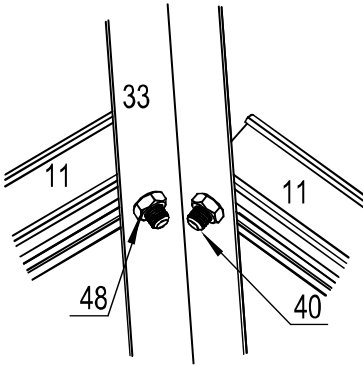
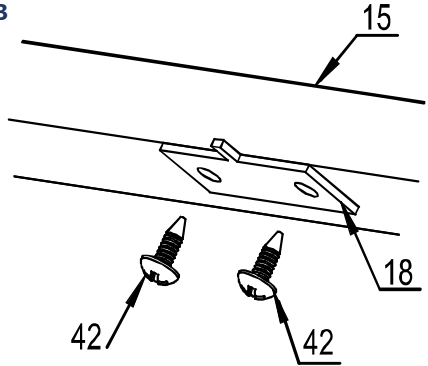
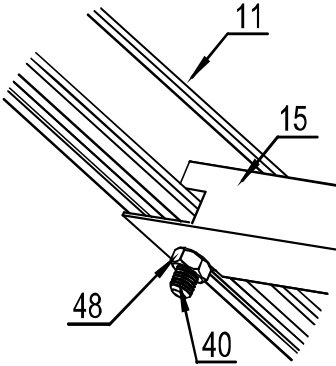
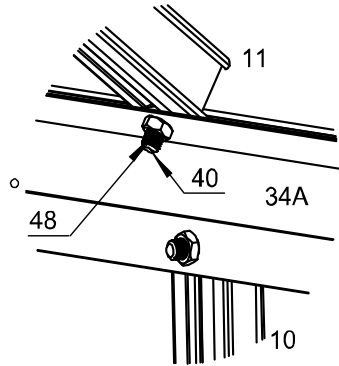
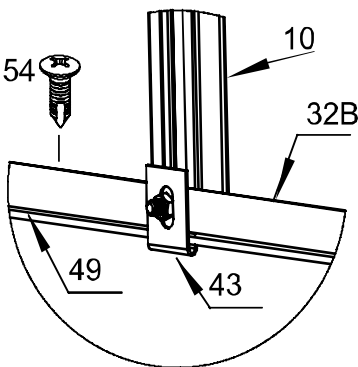
N.º	Imagen	Canti- dad	Medi- das (mm)
40		18	M6x10
42		4	M4x18
43		16	
48		18	M6
54		16	







La pieza 43 es necesaria para conectar la base del invernadero con el fundamento.



**A****B****C****D****E**

## FIJACIÓN DE LOS PANELES DE PC TRANSPARENTES

N.º	Imagen	Canti- dad	Medidas (mm)
1		11	605 x 1212
2		5	605 x 1130
3A		2	605 x 455
3B		2	605 x 455
4		1	605 x 585
5		1	595 x 550
6		1	605 x 675

N.º	Imagen	Canti- dad	Medidas (mm)
7		1	605 x 250
8		1	615 x 241
9		2	605 x 602
35		5	
47		162	
53		44	

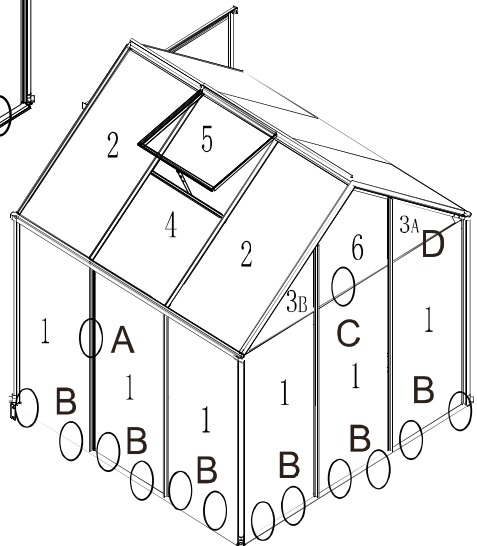
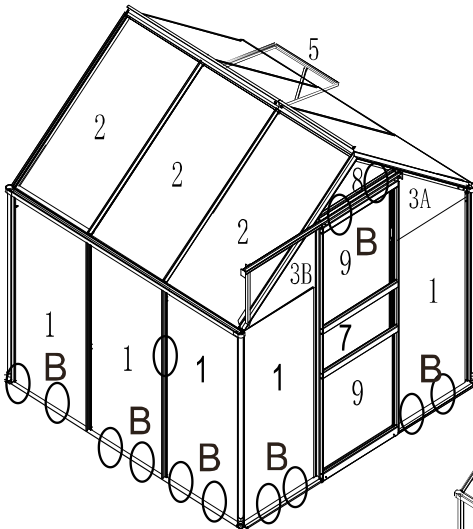

A



B

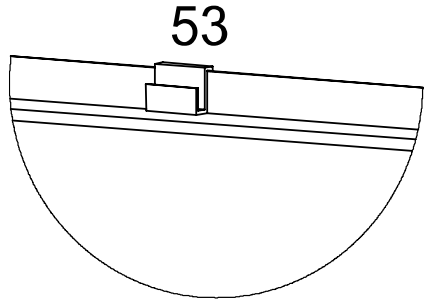

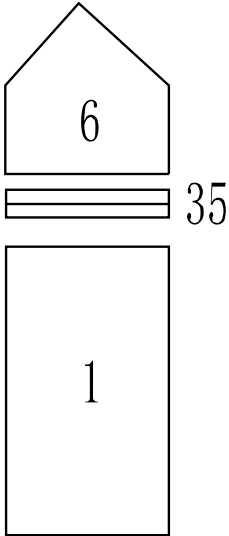

C



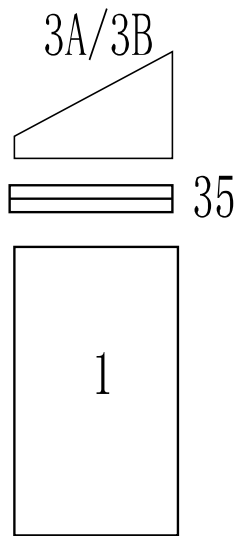

D



## INSTALACIÓN DE PUERTA CORREDERA Y VIERTEAGUAS

N.º	Imagen	Canti- dad	Medi- das (mm)
44A		2	
44B		2	
45A		1	

N.º	Imagen	Canti- dad	Medi- das (mm)
45B		1	
40		2	M6x10
48		2	M6

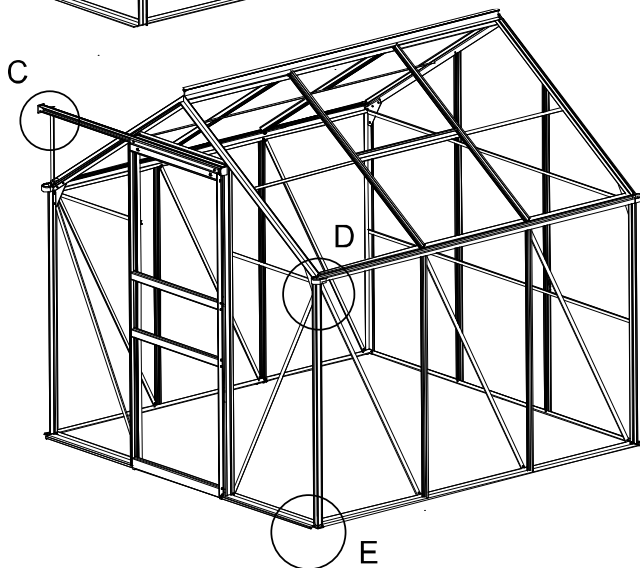
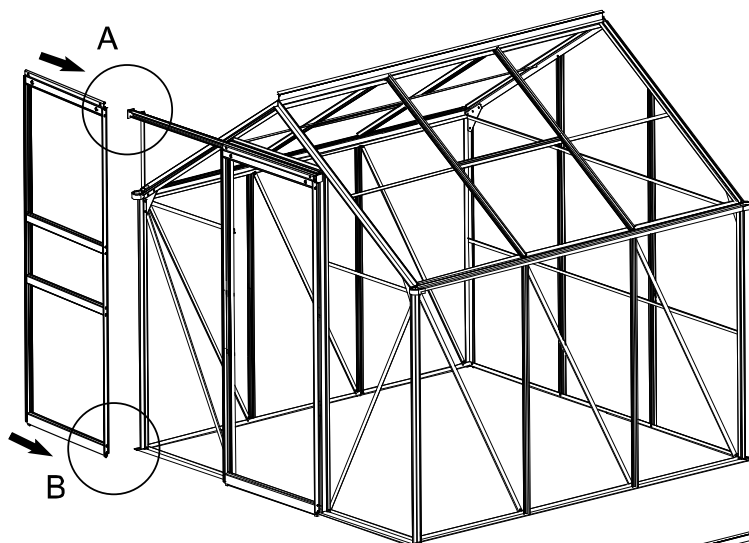

A

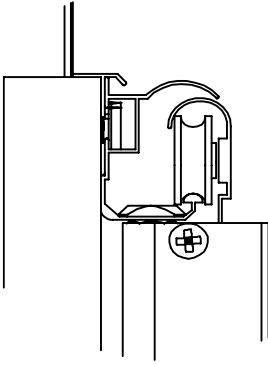

B

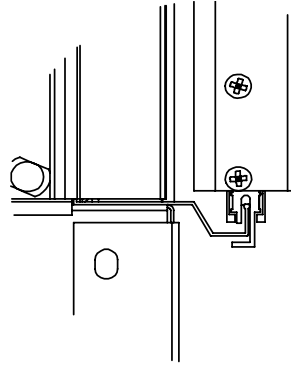

C

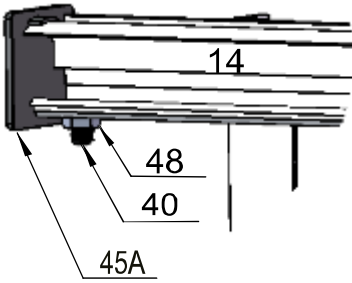

D

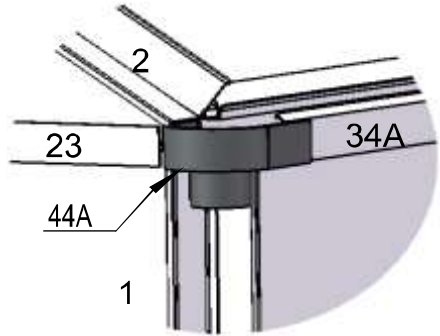

E

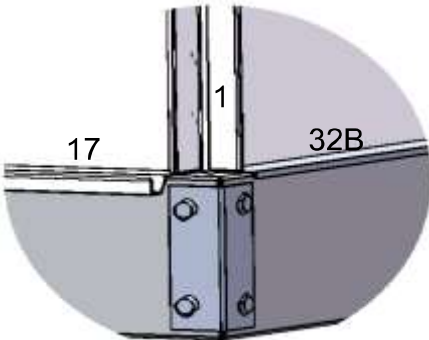

# GEBRUIKSAANWIJZING

## Beste klant,

Bedankt dat u heeft gekozen voor een product van ons bedrijf; u heeft met de aankoop van een van onze merkproducten een goede keuze gemaakt. Om aan de gewenste hoge kwaliteitsstandaard te voldoen, worden onze artikelen regelmatig gecontroleerd en voldoen ze uiteraard altijd aan de hoge eisen van de Europese Unie.

## INHOUDSOPGAVE

SYMBOLEN .....	135
ALGEMENE INFORMATIE .....	135
BEOOGD GEBRUIK .....	136
UITPAKINSTRUCTIES .....	136
KEUZE VAN LOCATIE .....	136
INSTRUCTIES VOOR DE MONTAGE .....	137
ONDERHOUDSINSTRUCTIES .....	137
VERWIJDERING .....	137
ONDERDELENLIJST .....	138
ONDERDELENLIJST PC-PANELEN .....	140
OPBOUW DAKLUIKEN .....	141
OPBOUW SCHUIFDEURFRAME .....	143
OPBOUW VOORFRAME .....	145
OPBOUW LINKERWAND .....	147
OPBOUW RECHTERWAND .....	149
OPBOUW ACHTERFRAME .....	151
FRAME VAN DE WANDEN MET ELKAAR VERBINDEN .....	153
DAKLUIK MONTEREN .....	155
BEVESTIGING VAN DE TRANSPARANTE PC-PANELEN .....	157
MONTAGE VAN SCHUIFDEUR EN DAKGOOT .....	159

## SYMBOLEN



### LEES DE GEBRUIKSAANWIJZING. BELANGRIJKE INSTRUCTIES. BEWAAR DEZE VOOR TOEKOMSTIG GEBRUIK!

Lees voor het eerste gebruik de hele gebruiksaanwijzing zorgvuldig door. Bewaar deze gebruiksaanwijzing voor toekomstig gebruik. Mocht u het product ooit doorgeven, zorg er dan voor dat u deze gebruiksaanwijzing ook doorgeeft.



### LET OP! POTENTIEEL GEVAAR!

Volg de veiligheids- en montage-instructies om het risico op verwondingen of schade aan het product te voorkomen.



### VERSTIKKINGSGEVAAR!

Houd kleine onderdelen en verpakkingsmateriaal uit de buurt van kinderen!



### WIJZIGINGEN AAN HET PRODUCT

Breng nooit wijzigingen aan het product aan! Door wijzigingen vervalt de garantie en kan het product onveilig of in het ergste geval zelfs gevaarlijk worden.

## ALGEMENE INFORMATIE

- Wij adviseren om het product met minimaal twee personen te monteren.
- Kies een locatie die voldoende ruimte biedt om rond de tuinkas te werken.

- Volg precies de stappen die in de instructies worden beschreven om een correcte montage te garanderen.
- Controleer voordat u met de montage begint of alle onderdelen aanwezig zijn.
- Zorg ervoor dat het funderingsframe plat op de grond ligt.
- De fundering moet vlak zijn. Egaliseer de grond als deze niet vlak is.
- De tuinkas moet stevig verankerd zijn aan de fundering om schade door harde wind te voorkomen.
- **LET OP!** Stap niet op het dak! Instortingsgevaar!
- Bij gebruik van een niet-betonnen fundering is het belangrijk dat de ondergrond stevig en vlak is. Het product moet op/in een fundering worden bevestigd! Alleen als de tuinkas nauwkeurig is uitgelijnd, kan deze blijvend en stabiel staan. Zelfs als de wanden enigszins scheef staan, kunnen ze niet meer goed in de daarvoor bestemde geleiders worden vastgehouden en kunnen ze door de wind gemakkelijk uit hun scharnieren worden getild.
- De fundering van de tuinkas moet in de grond verankerd/vastgezet worden. Het grote oppervlak van de tuinkas biedt een groot oppervlak voor de wind, wat kan resulteren in aanzienlijke verwondingen en/of materiële schade.
- Maak nooit vuur in de kas en houd het uit de buurt van open vuur en vonken!
- Gebruik dit product niet als er onderdelen ontbreken, beschadigd of versleten zijn.
- Zorg ervoor dat u geen personen en/of dieren opsluit in de tuinkas!
- Vermijd zoveel mogelijk overhangende bomen, want vallende bladeren moeten regelmatig worden verwijderd en afgebroken takken vormen een bron van gevaar.
- Kleine bomen, struiken of hekken in de buurt kunnen nuttig zijn als bescherming tegen wind.
- **WAARSCHUWING!** Bij wind en storm moeten de deuren en ramen gesloten zijn.

## **BEOOGD GEBRUIK**

De tuinkas is ontworpen voor het kweken en telen van groenten, bloemen en andere planten. De berging is niet geschikt voor het opslaan van gevaarlijke stoffen en voor het onderbrengen van mensen of dieren. Gebruik het product alleen voor het beoogde doel. De fabrikant aanvaardt geen aansprakelijkheid voor schade als gevolg van onbeoogd gebruik. Elke wijziging aan het product kan een negatieve invloed hebben op de veiligheid, gevaren veroorzaken en de garantie ongeldig maken.

**Alleen voor huishoudelijk gebruik en niet voor commerciële doeleinden.**

## **UITPAKINSTRUCTIES**

Open de doos en haal alle onderdelen en elementen van de set eruit en plaats de componenten op de doos of op een ander schoon oppervlak. Zo beschermt u uw nieuwe product. Controleer het product na het uitpakken op volledigheid en beschadigingen. Latere klachten kunnen niet in behandeling worden genomen.

## **KEUZE VAN LOCATIE**

Maak uzelf vertrouwd met de lokale regels en voorschriften voordat u begint met de montage. Let er bij het kiezen van een geschikte locatie voor de tuinkas op dat de ondergrond stabiel en vlak is en zorg ervoor dat er geen locatie wordt gekozen waar de tuinkas helemaal vrij staat! Er moet een bepaalde bescherming tegen storm en stormachtige windstoten worden gegarandeerd. Er kan schade ontstaan als de berging helemaal vrij staat.

## INSTRUCTIES VOOR DE MONTAGE

Volg hiervoor de afbeeldingen van de montagestappen.



Draag tijdens de montage altijd veiligheidshandschoenen, lange mouwen en een veiligheidsbril. Sommige onderdelen kunnen scherpe randen hebben en verwondingen veroorzaken!

Scan de QR-code naar om naar de montagevideo te gaan.

- Voordat u de tuinkas opzet, is het belangrijk om een geschikte fundering voor te bereiden. Dergelijke funderingen (bekistingshulpmiddelen) kunt u in onze onlineshop kopen.
- Zet de kas niet op in winderige of natte omstandigheden.
- Haal de stukken uit de doos en sorteer ze op nummer. Zorg ervoor dat u over alle benodigde onderdelen voor de montage beschikt.
- Maak uzelf vertrouwd met hoe het gereedschap werkt.
- Houd kinderen en huisdieren uit de buurt van de montageplaats.
- Als u een ladder gebruikt, zorg er dan voor dat deze stabiel staat. Plaats nooit uw volledige gewicht op een deel van het dak of de tuinkas.
- Sommige montagestappen moeten door twee personen worden uitgevoerd.
- Bewaar kleine onderdelen (schroeven, enz.) in de dozen en zakken, zodat ze niet verloren gaan.
- Elk onderdeel is genummerd en het bijbehorende nummer vindt u in de montagehandleiding.
- Begin met de montage door de onderdelen met hetzelfde nummer in afzonderlijke groepen rond de installatieplaats te plaatsen.
- Het aluminium frame van de tuinkas wordt als eerste gebouwd en als laatste worden de PC-panels geplaatst.

## ONDERHOUDSINSTRUCTIES

- Gebruik voor het reinigen een spons en warm zeepsop. Gebruik geen reinigingsmiddelen die oplosmiddelen bevatten of wasmiddelen, zoals bleekmiddel, aangezien deze het product kunnen beschadigen.
- Gebruik bij werkzaamheden aan de tuinkas altijd geschikt gereedschap.
- Vervang beschadigde delen van de tuinkas onmiddellijk! Mensen en dieren kunnen door beschadigde onderdelen gewond raken!
- Zorg ervoor dat u het dak in de winter zo sneeuwvrij mogelijk houdt. Het kan instorten onder te veel sneeuwlast. Een sneeuwdiepte van meer dan 10 cm kan gevaarlijk zijn (laaghoogtes van 36 cm voor droge sneeuw, 10 cm voor waterige sneeuw en 5,5 cm voor ijs komen overeen met een gewicht van ca. 50 kg/m<sup>2</sup>).
- Indien u onvoorziene problemen ondervindt, kunt u contact opnemen met ons serviceteam. We helpen u graag.













## VERWIJDERING







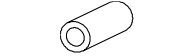
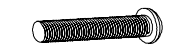
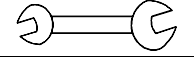

Voer aan het einde van de lange levensduur van het product de waardevolle grondstoffen op de juiste manier af, zodat een goede recycling kan plaatsvinden. Als u niet zeker weet wat u moet doen, helpen de plaatselijke afvalverwerkingsbedrijven of recyclingcentra u graag verder.

## ONDERDELENLIJST (doos 1/2)



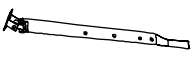
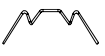

Nr.	Afbeelding	Hoeveelheid	Afmetingen (mm)
1		4	1215
2		1	1134
3		1	1134
4		1	1134
5		1	1134
6		1	1647
7		1	1647
8		1	1655
9		1	1655
10		4	1215
11		4	1114
12		1	610
13		4	
14		1	1260
15		1	634
16		2	911
16A		1	170
17		1	1355
17A		1	467
17B		1	170





Nr.	Afbeelding	Hoeveelheid	Afmetingen (mm)
18		2	
19		1	380
20		2	1608
21		4	1220
21A		4	610
21B		2	
22		4	1350
22A		2	1362
23		2	594
24		1	610
25		2	1304
26		2	610
27		1	610
28		2	520
29		1	608
30		1	595
31		1	595
32A		2	1432
32B		2	390
32C		2	170

Nr.	Afbeelding	Hoeveelheid	Afmetingen (mm)
33		1	1433
33A		1	388
33C		1	170
34A		2	1433
34B		2	390
34C		2	170
35		5	603
36		2	
37		1	
38		1	M5x30
39		2	
40		138	M6x10

Nr.	Afbeelding	Hoeveelheid	Afmetingen (mm)
41		14	M5x18
41A		2	M4x18
42		6	M4x8
44A		2	
44B		2	
45A		1	
45B		1	
46		1	
47		162	
48		137	M6
53		44	

## ONDERDELENLIJST PC-PANELEN (doos 2/2)

Nr.	Afbeelding	Hoeveelheid	Afmetingen (mm)
1		11	605 x 1212
2		5	605 x 1130
3A		2	605 x 455
3B		2	605 x 455
4		1	605 x 585

Nr.	Afbeelding	Hoeveelheid	Afmetingen (mm)
5		1	595 x 550
6		1	605 x 675
7		1	605 x 250
8		1	615 x 241
9		2	605 x 602

## INSTRUCTIES VOOR DE MONTAGE VAN DE PC-PANELEN



Foto van de PC-panels van 4 mm

De panelen hebben een witte beschermfoliezijde zonder UV-bescherming en een groene beschermfoliezijde met UV-bescherming. De groene kant moet aan de buitenkant zitten.

De folie beschermt de panelen, daarom raden wij aan om de beschermfolies pas te verwijderen nadat de panelen in het frame van de tuinkas zijn geplaatst, zodat u weet welke kant UV-beschermd is en de zijkanen niet met elkaar verwisseld worden tijdens de montage.

Een goede optie is om ongeveer 5 cm van de beschermfolie van alle randen van het paneel te verwijderen voordat u de panelen in het aluminium frame monteert (zodat deze niet onder de schroeven en aluminium strips komt). Zodra de panelen aan het frame zijn bevestigd, kunt u de beschermfolies volledig verwijderen. Behandel de panelen met bijzondere zorg om krassen tijdens de installatie te voorkomen.

Wij raden u aan het volgende gereedschap klaar te hebben voor de montage:

- veiligheidshandschoenen
- lintmeter
- platte schroevendraaier
- accuschroevendraaier



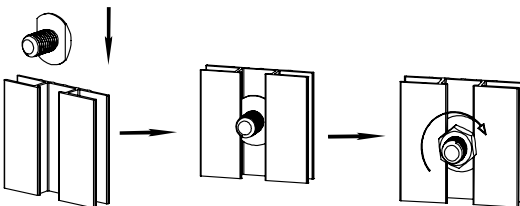

(Een schroevendraaier is meegeleverd in de verpakking.)







Zo duw je de schroeven in de groeven van de aluminium strips.

## OPBOUW DAKLUIKEN

Leg de onderdelen zoals hieronder weergegeven, plaats de schroeven (nr. 40) van boven naar beneden, monteer eerst de onderdelen 28 en 31, dan de plaat (onderdeel 5) en in de volgende stap onderdeel 30.

Nr.	Afbeelding	Hoeveelheid	Afmeting en (mm)
28		2	520
30		1	595
31		1	595
40		4	M6x10

Nr.	Afbeelding	Hoeveelheid	Afmeting en (mm)
42		2	M4x8
46		1	
48		4	M6
5		1	595 x 550

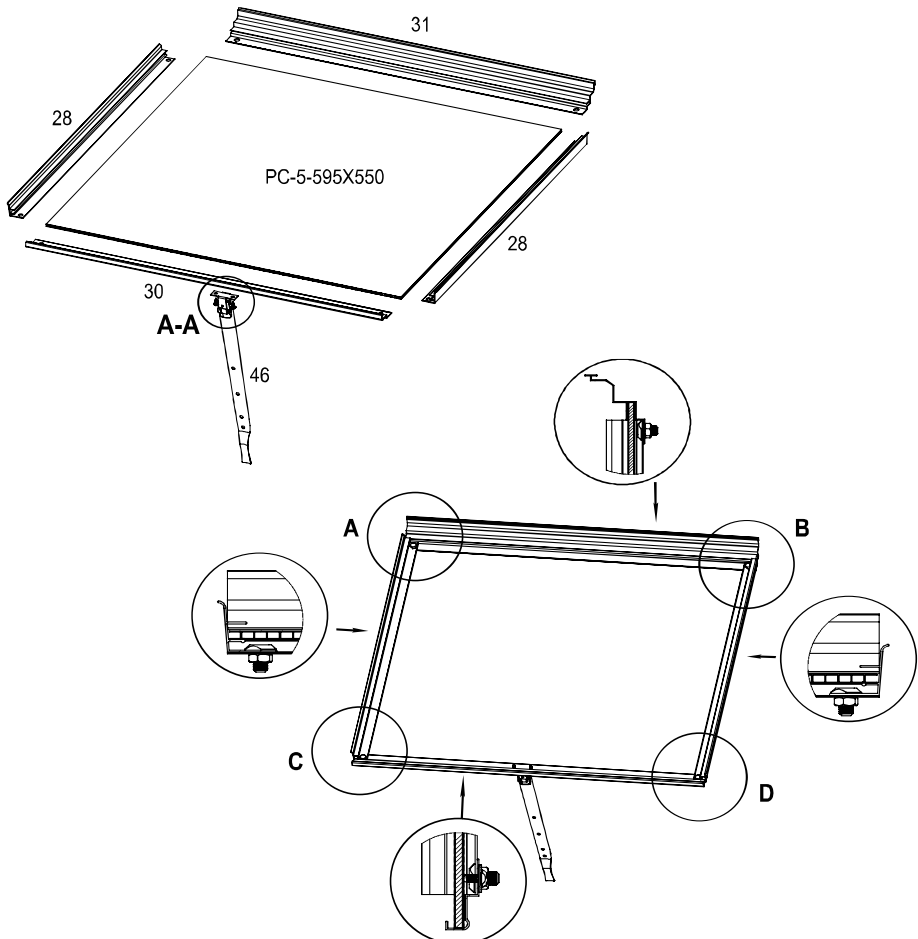

De zijde met de groene beschermfolie met UV-bescherming moet naar de zon gericht zijn. De zijde met de witte beschermfolie zonder UV-bescherming moet naar de binnenkant van de tuinkas gericht zijn.

**AA**

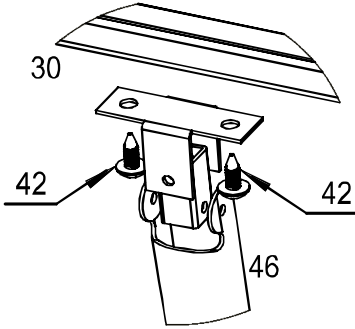

**A**

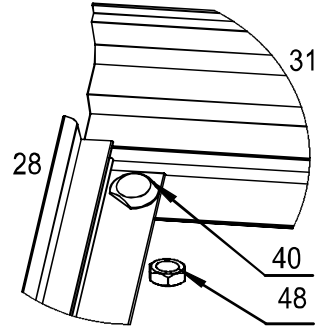

Bevestig de beugel in de daarvoor bestemde schroefgaten.

**B**

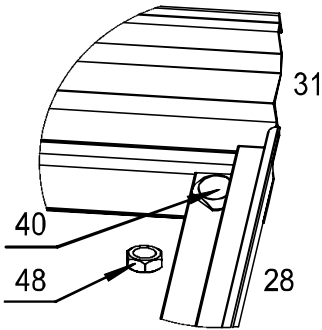

**C**

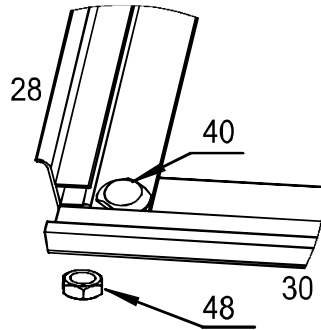





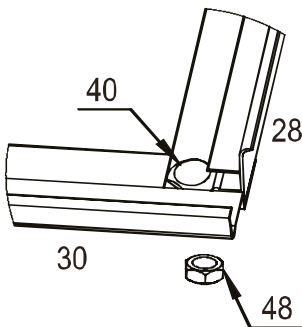





Draai de schroef en moer pas vast nadat onderdeel 30 in de schroefpositie is geplaatst.

**D**



## OPBOUW SCHUIFDEURFRAME

Nr.	Afbeelding	Hoeveelheid	Afmetingen (mm)
20		2	1608
24		1	610
26		2	610
27		1	610
29		1	608

Nr.	Afbeelding	Hoeveelheid	Afmetingen (mm)
36		2	
40		2	M6x10
41		14	M5x18
41A		2	M4x18
48		2	M4x8

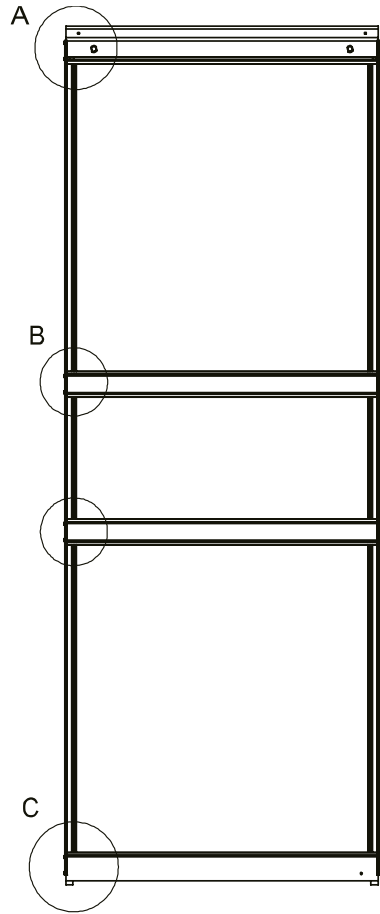
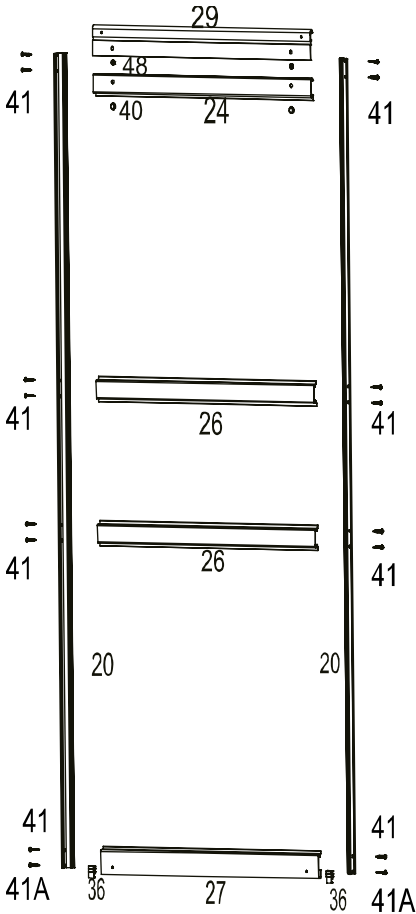

A

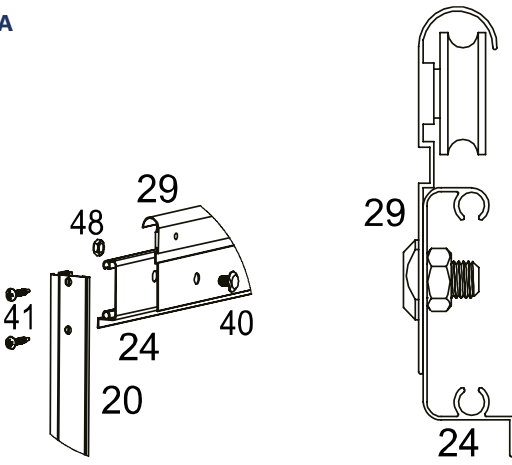

B

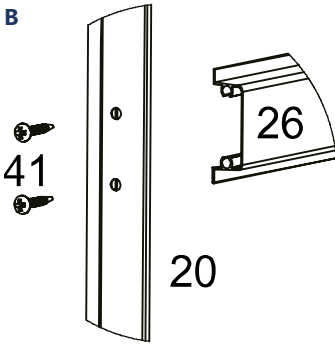

C

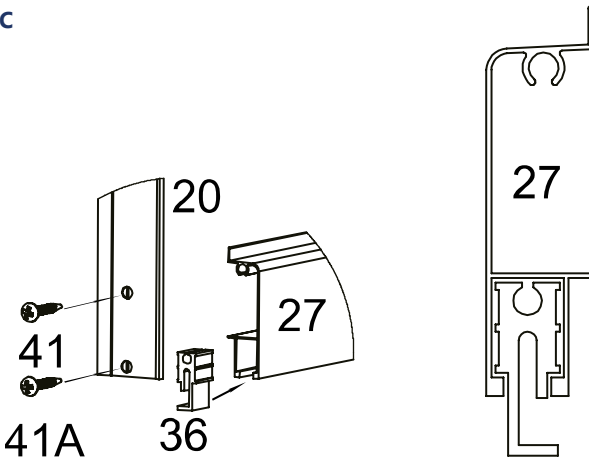

## OPBOUW VOORFRAME

Nr.	Afbeelding	Hoeveelheid	Afmetingen (mm)
1		2	1215
2		1	1134
3		1	1134
6		1	1647
7		1	1647
12		1	610
13		2	
14		1	1260
17		1	1335
17A		1	467

Nr.	Afbeelding	Hoeveelheid	Afmetingen (mm)
17B		1	170
19		1	380
23		2	594
25		2	1304
37		1	
38		1	
40		26	M6x10
48		27	M6

Let bij de montage op de instructies voor deel 2 en deel 3.  
Voorframe gezien vanuit de tuinkas (aanzicht hieronder).

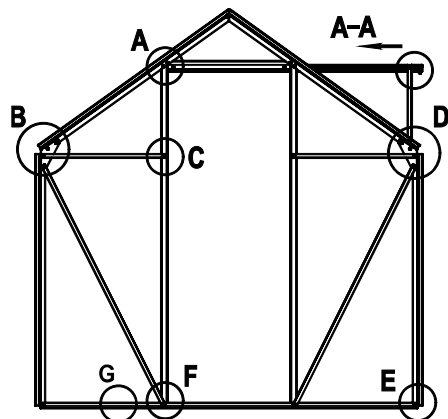
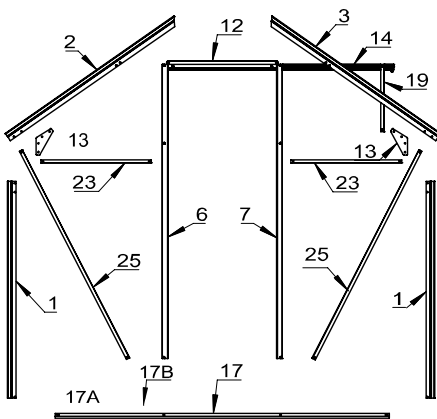

Richting van de afbeelding gezien vanaf de buitenkant van de tuinkas.

**AA**



Foto na installatie van onderdeel nr. 14.

**A**

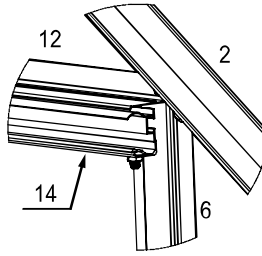
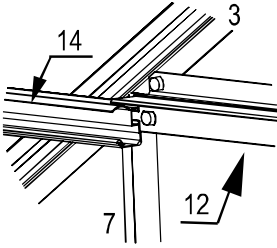
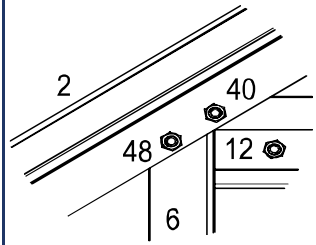

Paragraaf A toont de binnenkant, let op de montage-instructies van onderdelen 40 en 48.

**B**

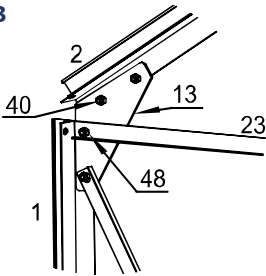

**C**

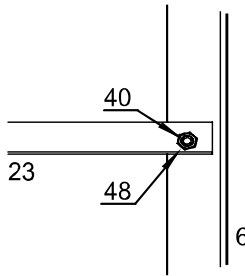

**D**

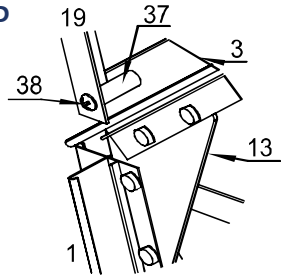

**E**

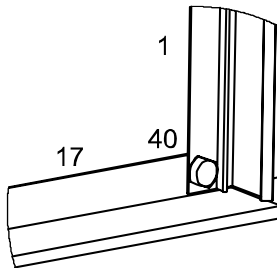

**F**

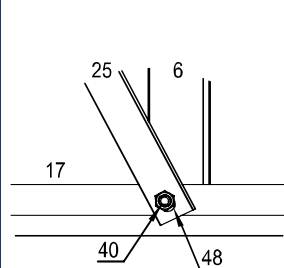

**G**

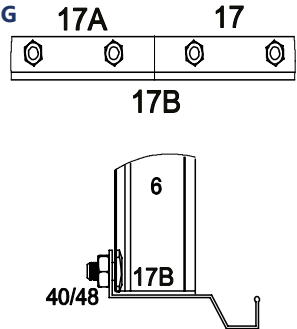

Detailweergave

## OPBOUW LINKERWAND (gezien vanaf de deur)

Nr.	Afbeelding	Hoeveelheid	Afmetingen (mm)
10		2	1215
22		2	1304
22A		1	1362
21B		1	
32A		1	1432
32B		1	390
32C		1	170

Nr.	Afbeelding	Hoeveelheid	Afmetingen (mm)
34A		1	1433
34B		1	390
34C		1	170
40		18	M6x10
48		18	M6

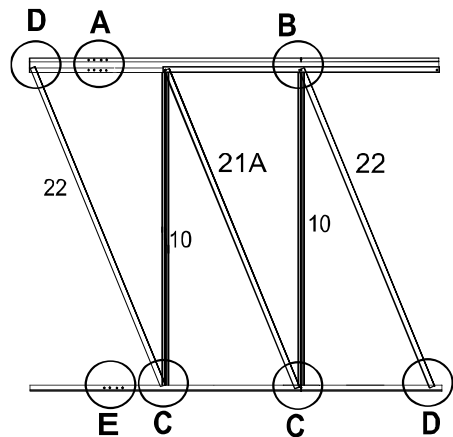
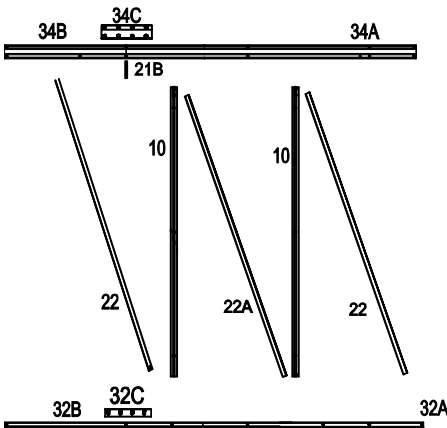

Monteer eerst afbeelding A en E.

Steek beslag 21B tussen 34A/34B in de richting van de pijl en zet deze met 34C vast met schroeven en moeren.

Draai eerst de schroeven vast voordat u de onderdelen 32 en 34 aansluit op de onderdelen 10, 21A en 22.

Zijwand van binnen gezien.

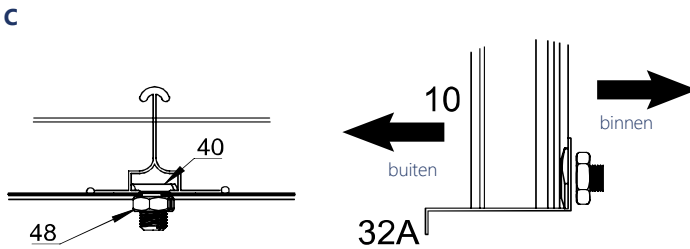
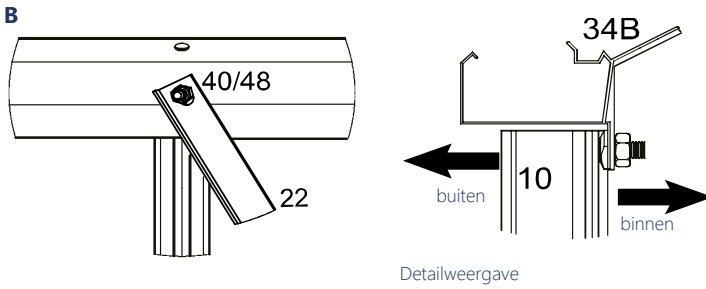
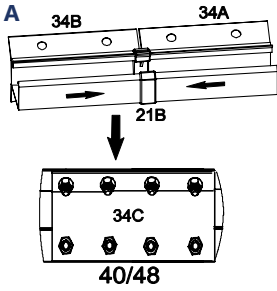

Bevestiging van onderdeel 10 aan onderdeel 32A

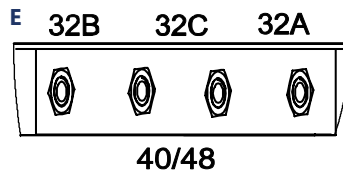
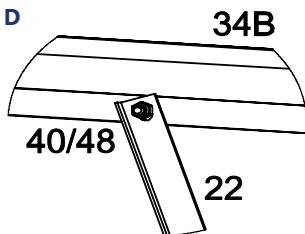

## OPBOUW RECHTERWAND (gezien vanaf de deur)

Nr.	Afbeelding	Hoeveelheid	Afmetingen (mm)
10		2	1215
22		2	1304
22A		1	1362
21B		1	
32A		1	1432
32B		1	996
32C		1	170

Nr.	Afbeelding	Hoeveelheid	Afmetingen (mm)
34A		1	1433
34B		1	390
34C		1	170
40		18	M6x10
48		18	M6

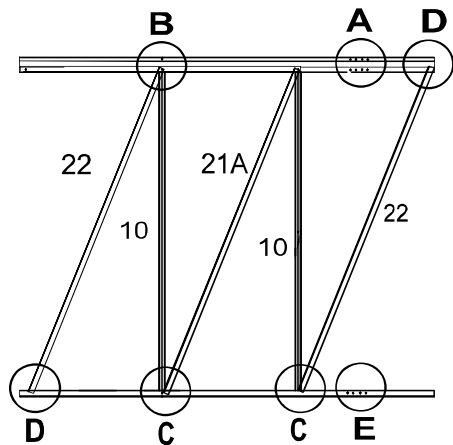
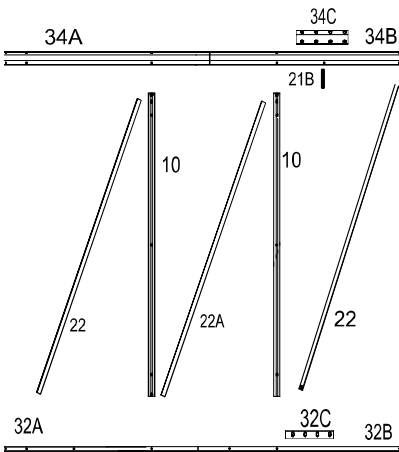

Monteer eerst afbeelding A en E.

Steek beslag 21B tussen 34A/34B in de richting van de pijl en zet deze met 34C vast met schroeven en moeren.

Draai eerst de schroeven vast voordat u de onderdelen 32 en 34 aansluit op de onderdelen 10, 21A en 22.

Zijwand van binnen gezien.

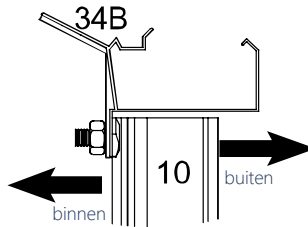
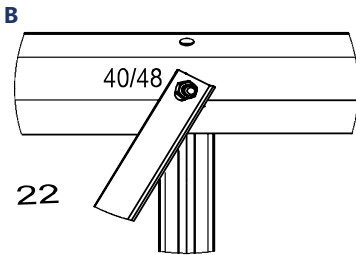
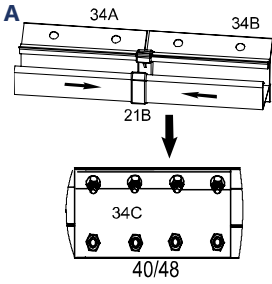

Detailweergave

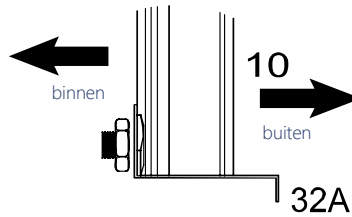
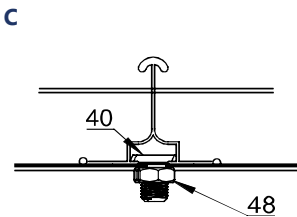

Bevestiging van onderdeel 10 aan onderdeel 32A

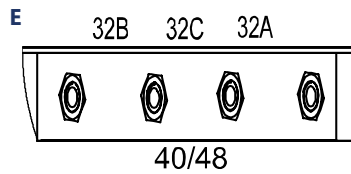
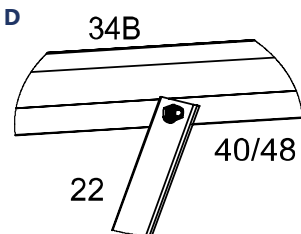

## OPBOUW ACHTERFRAME

Nr.	Afbeelding	Hoeveelheid	Afmetingen (mm)
1		2	1215
4		1	1134
5		1	1134
8		1	1655
9		1	1655
13		2	

Nr.	Afbeelding	Hoeveelheid	Afmetingen (mm)
16		2	911
16A		1	170
21		2	1220
21A		2	610
40		24	M6x10
48		24	M6

Achterwand van binnen gezien

De schroeven zijn van binnenuit vastgezet met moeren

Draai de schroeven en moeren vast voor weergave C en E

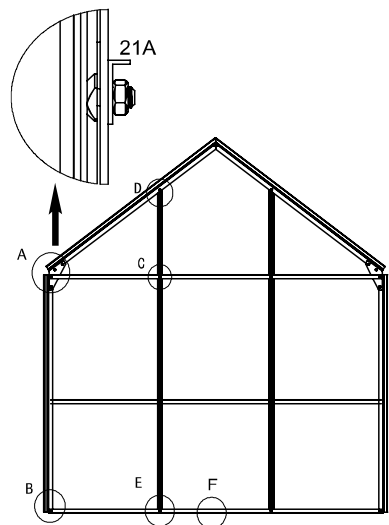
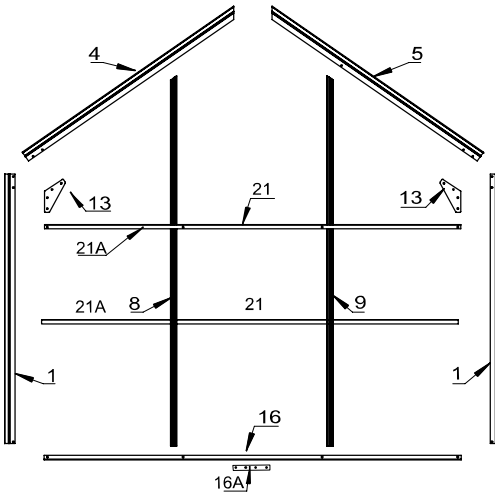

**A**

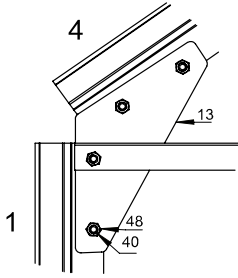

**B**

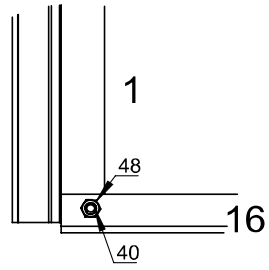

**C**

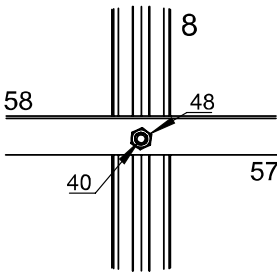

**D**

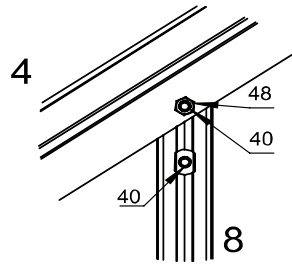

**E**

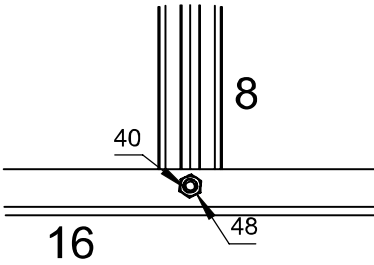

**F**

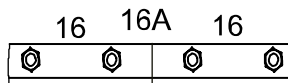
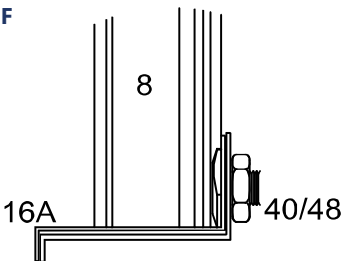

Detailweergave

## FRAME VAN DE WANDEN MET ELKAAR VERBINDEN

Nr.	Afbeelding	Hoeveelheid	Afmetingen (mm)
33		1	1433
33A		1	388
33C		1	170

Nr.	Afbeelding	Hoeveelheid	Afmetingen (mm)
40		24	M6x10
48		24	M6

Voor het verbinden van de frame-elementen zijn minimaal 2 tot 3 personen nodig.

Let op de opstelling van onderstaande aluminium profielen en het gebruik van schroeven voor de bevestiging.

Nadat u klaar bent met het monteren van de wandframes, monteert u de nok deel 33.

De uiteindelijke stabiliteit van de tuinkas wordt bereikt nadat u alle schroeven in het aluminium frame heeft vastgedraaid en de panelen heeft geïnstalleerd.

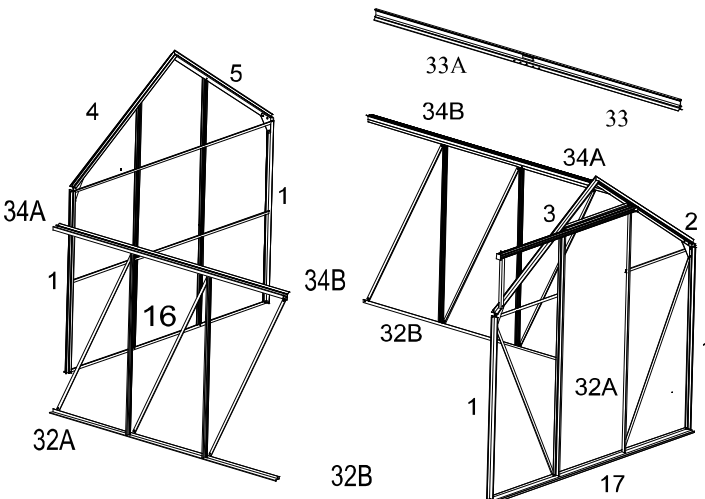
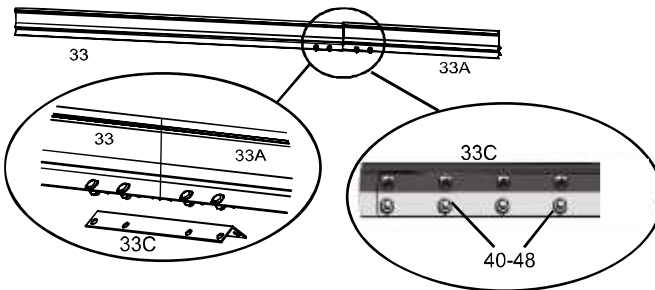

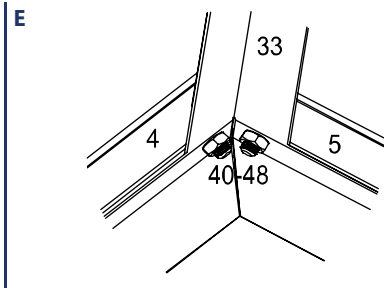
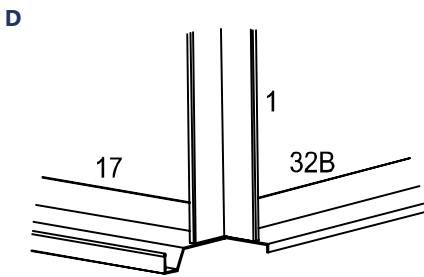
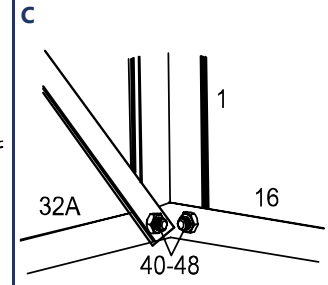
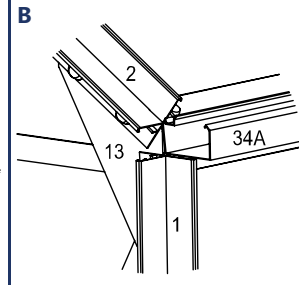
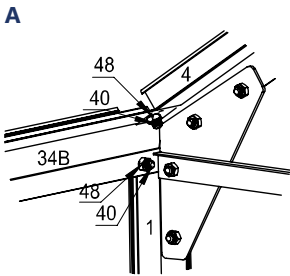
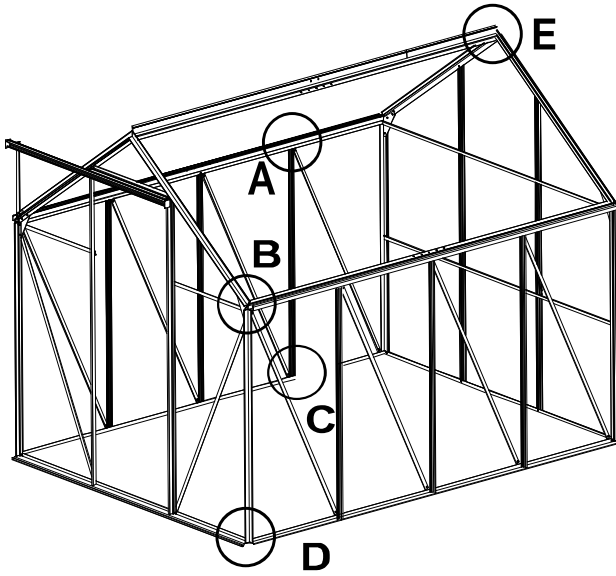

## DAKLUIK MONTEREN

Nr.	Afbeelding	Hoeveelheid	Afmetingen (mm)
11		4	1114
15		1	634
18		2	
21		2	1220
21A		2	610





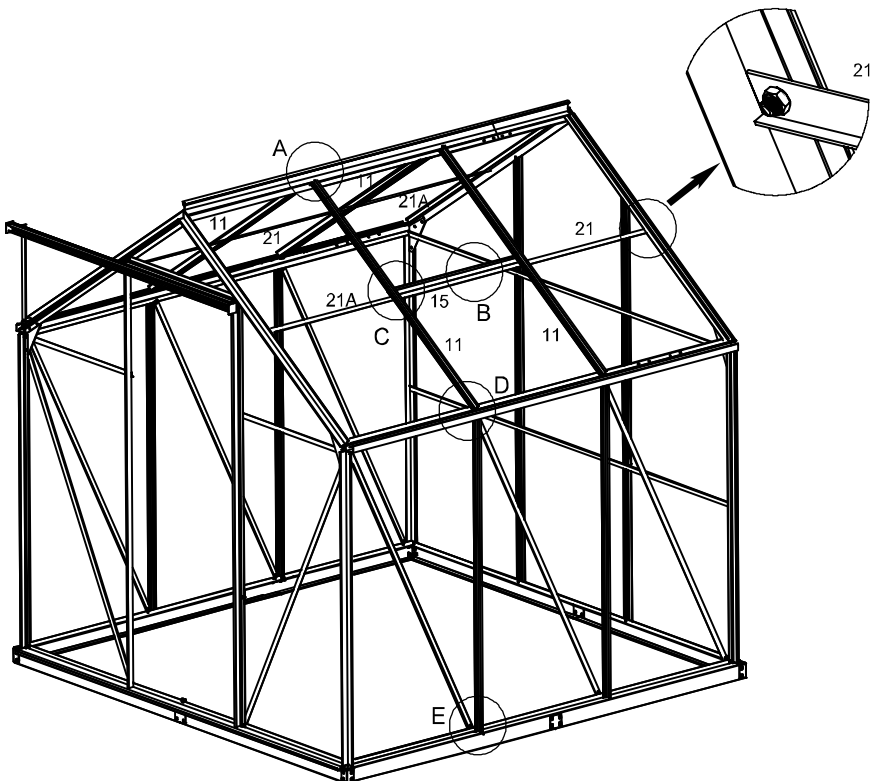

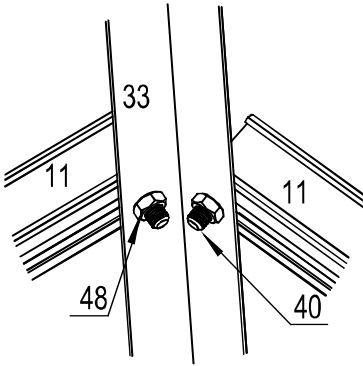
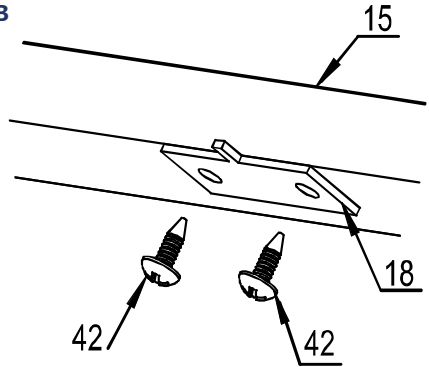
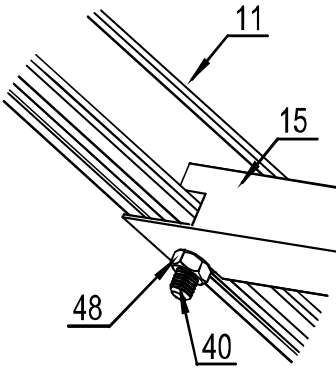
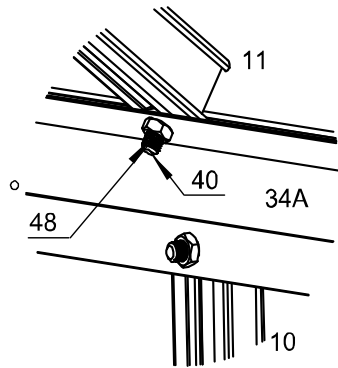
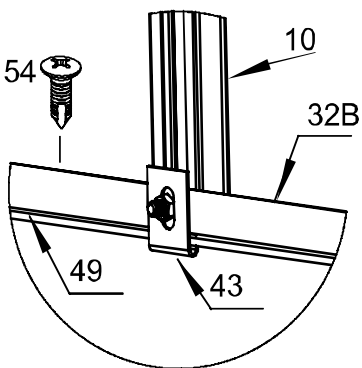
Nr.	Afbeelding	Hoeveelheid	Afmetingen (mm)
40		18	M6x10
42		4	M4x18
43		16	
48		18	M6
54		16	







Onderdeel 43 is nodig voor de aansluiting van de vloer van de tuinkas op de fundering.



**A****B****C****D****E**

## BEVESTIGING VAN DE TRANSPARANTE PC-PANELEN

Nr.	Afbeelding	Hoeveelheid	Afmetingen (mm)
1		11	605 x 1212
2		5	605 x 1130
3A		2	605 x 455
3B		2	605 x 455
4		1	605 x 585
5		1	595 x 550
6		1	605 x 675

Nr.	Afbeelding	Hoeveelheid	Afmetingen (mm)
7		1	605 x 250
8		1	615 x 241
9		2	605 x 602
35		5	
47		162	
53		44	

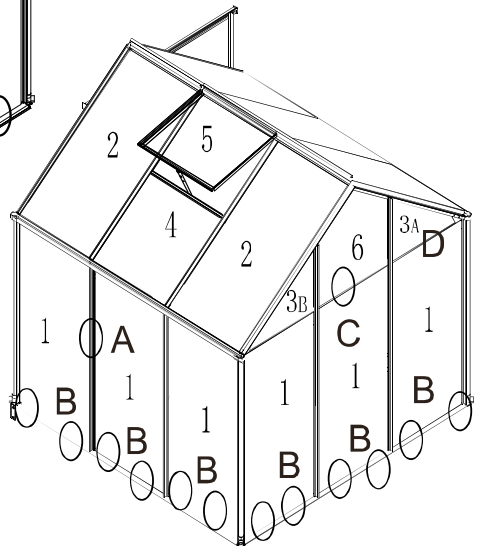
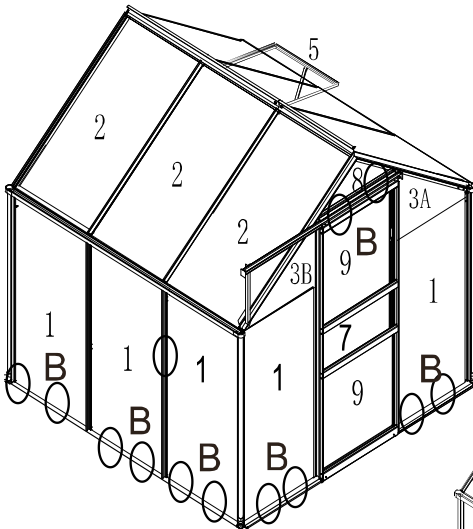

A



B

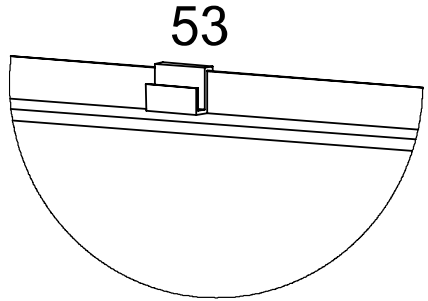

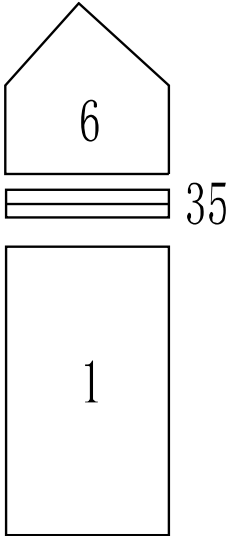

C



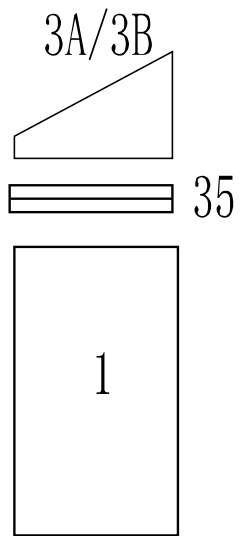

D



## MONTAGE VAN SCHUIFDEUR EN DAKGOOT

Nr.	Afbeelding	Hoeveelheid	Afmetingen (mm)
44A		2	
44B		2	
45A		1	

Nr.	Afbeelding	Hoeveelheid	Afmetingen (mm)
45B		1	
40		2	M6x10
48		2	M6

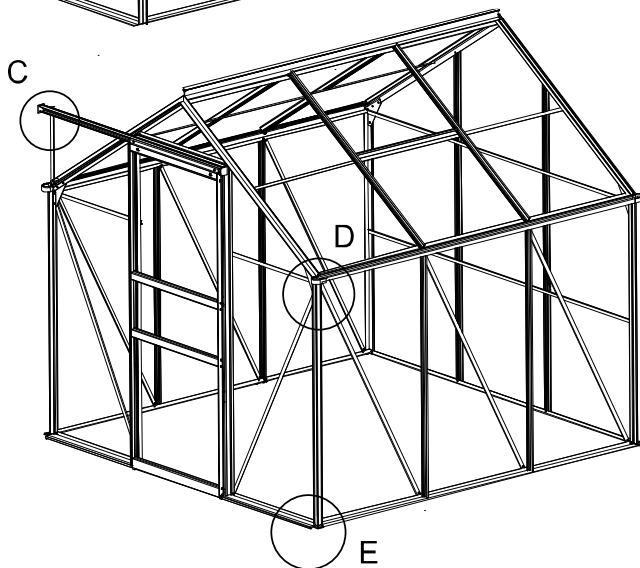
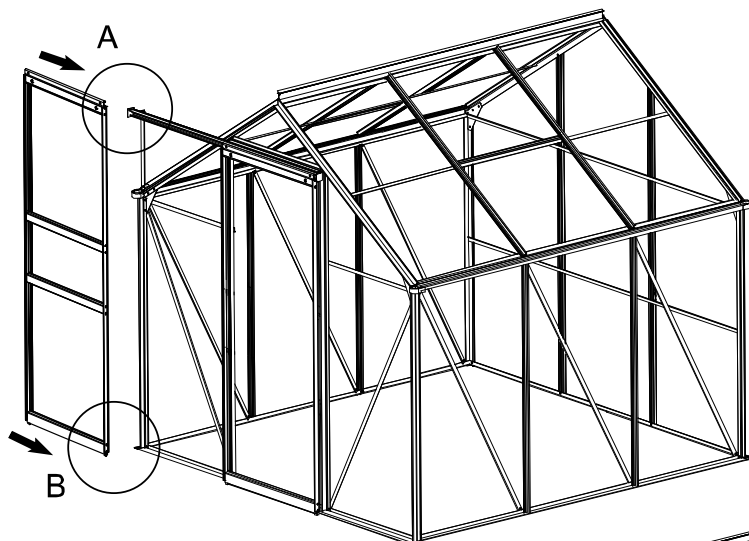

A

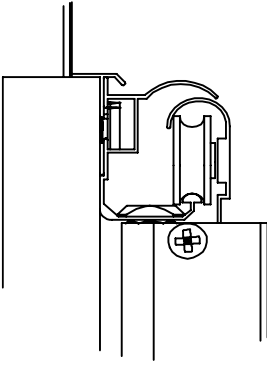

B

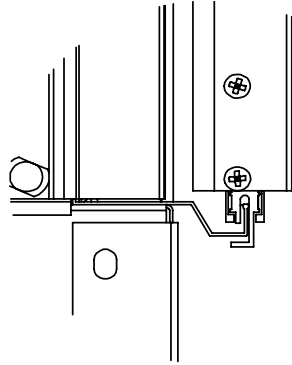

C

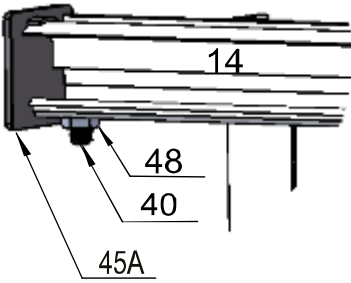

D

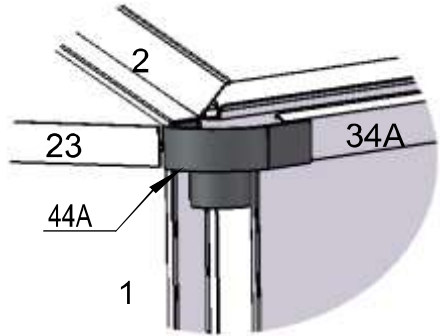

E

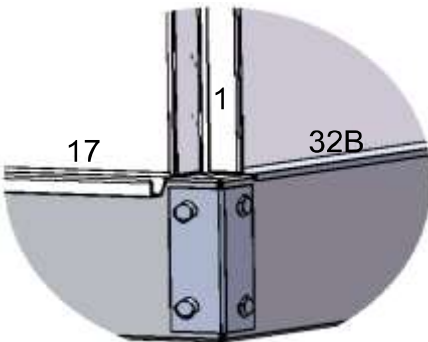

# INSTRUKCJA

## Szanowni Klienci,

dziękujemy, że zdecydowali się Państwo na zakup naszego produktu. Decydując się na jeden z naszych markowych produktów, dokonali Państwo dobrego wyboru. W celu spełnienia wysokich standardów jakościowych nasze artykuły poddawane są regularnym kontrolom i zawsze spełniają wysokie wymogi Unii Europejskiej.

## SPIS TREŚCI

SYMBOLE.....	161
WSKAZÓWKI OGÓLNE .....	161
UŻYTKOWANIE ZGODNIE Z PRZEZNACZENIEM .....	162
ROZPAKOWANIE .....	162
WYBÓR LOKALIZACJI .....	162
WSKAZÓWKI DOTYCZĄCE MONTAŻU .....	163
KONSERWACJA I PIELĘGNACJA .....	163
UTYLIZACJA .....	164
LISTA CZĘŚCI .....	165
LISTA CZĘŚCI PANELI PC .....	167
MONTAŻ OKNA DACHOWEGO .....	168
MONTAŻ RAMY DRZWI PRZESUWNYCH .....	170
MONTAŻ RAMY PRZEDNIEJ .....	172
MONTAŻ LEWEJ ŚCIANY .....	174
MONTAŻ PRAWĘJ ŚCIANY .....	176
MONTAŻ RAMY ŚCIANY TYLNEJ .....	178
ŁĄCZENIE RAM ŚCIAN .....	180
MONTAŻ RAMY DACHOWEJ .....	182
MOCOWANIE PRZEZROCZYSTYCH PANELI PC .....	184
MONTAŻ DRZWI PRZESUWNYCH I RYNNY DESZCZOWEJ .....	186

## SYMBOLE



### PRZECZYTAĆ INSTRUKCJĘ OBSŁUGI. WAŻNE WSKAZÓWKI: ZACHOWAĆ W CELU PÓŹNIEJSZEGO UŻYCIA!

Przed pierwszym użyciem należy dokładnie przeczytać całą instrukcję. Prosimy zachować tę instrukcję w celu jej późniejszego użycia. W przypadku przekazania produktu innemu użytkownikowi należy przekazać mu także tę instrukcję.



### UWAGA! POTENCJALNE NIEBEZPIECZEŃSTWO!

Przestrzegać wskazówek dotyczących bezpieczeństwa i instrukcji montażu, aby uniknąć ryzyka urazów lub uszkodzenia produktu.



### NIEBEZPIECZEŃSTWO ZADŁAWIENIA!

Trzymać drobne części i materiał opakowaniowy z dala od dzieci!



### MODYFIKACJE PRODUKTU

Nigdy nie dokonywać modyfikacji produktu! Wskutek modyfikacji wygasa gwarancja, a produkt może stać się niesprawny lub, w najgorszym wypadku, nawet niebezpieczny.

## WSKAZÓWKI OGÓLNE

- Zalecamy, aby montaż wykonywany był przez co najmniej 2 osoby.
- Wybrać lokalizację, która zapewnia odpowiednio dużo miejsca na prace wokół szklarni.

- Postępować dokładnie według kroków zaleconych w instrukcji, aby zapewnić prawidłowy montaż.
- Przed rozpoczęciem montażu upewnić się, że są wszystkie potrzebne części.
- Upewnić się, że rama fundamentowa leży płasko na podłożu.
- Fundament musi być równy. Jeśli na podłożu występują nierówności, należy je zniwelować.
- Szklarnia musi być trwale zamocowana do fundamentu, aby zapobiec jej uszkodzeniu przez silny wiatr.
- **UWAGA!** Nie wchodzić na dach! Niebezpieczeństwo przewrócenia się szklarni!
- W przypadku zastosowania fundamentu, który nie jest wykonany z betonu, należy upewnić się, że podłoże jest twarde i równe. Produkt musi być zamocowany w fundamencie! Szklarnia będzie mogła stać trwale i stabilnie tylko wtedy, gdy zostanie dokładnie wypoziomowana. Nawet lekkie przekrzywienie ścian może spowodować, że nie będą one prawidłowo utrzymywane w specjalnych prowadnicach i mogą zostać łatwo wyrwane z zawiasów przez wiatr.
- Fundament szklarni koniecznie musi być zakotwiczony/przymocowany do podłoża. Duża powierzchnia szklarni jest szczególnie narażona na działanie wiatru, co może skutkować poważnymi obrażeniami i/lub stratami materialnymi.
- Nie wolno rozpałać ognia w szklarni oraz chronić ją przed otwartym ogniem i iskrami!
- Nie korzystać z tego produktu w przypadku brakujących części oraz w przypadku uszkodzonych lub zużytych części.
- Pilnować, aby w szklarni nie zostali zamknięci ludzie i/lub nie zostały uwięzione zwierzęta!
- W miarę możliwości nie stawiać szklarni pod drzewami, ponieważ spadające liście wymagają regularnego sprzątnięcia, a odłamujące się gałęzie stanowią źródło zagrożeń.
- Niskie drzewa, krzewy lub płoty w pobliżu mogą służyć jako osłona przed wiatrem.
- **OSTRZEŻENIE!** Podczas wiatru i burzy drzwi i okna muszą być zamknięte.

## UŻYTKOWANIE ZGODNIE Z PRZEZNACZENIEM

Szklarnia jest przeznaczona do uprawy warzyw, kwiatów i innych roślin. Szklarnia nie nadaje się do składowania materiałów niebezpiecznych. Nie powinni w niej także przebywać zamknięci ludzie ani zamknięte zwierzęta. Stosować produkt tylko zgodnie z jego przeznaczeniem. Producent nie odpowiada za szkody powstałe wskutek niewłaściwego użytkowania. Wszelkie modyfikacje produktu mogą negatywnie wpłynąć na bezpieczeństwo jego użytkowania, spowodować zagrożenia i prowadzą do wygaśnięcia gwarancji.

**Produkt jest przeznaczony tylko do użytku domowego i niekomercyjnego.**

## ROZPAKOWANIE

Otworzyć karton, wyjąć wszystkie elementy i części zestawu i umieścić te komponenty na wierzchniej stronie kartonu lub na innej czystej powierzchni. Zapewnia to ochronę nowego produktu. Po rozpakowaniu skontrolować produkt pod względem kompletności lub uszkodzeń. Późniejsze reklamacje nie będą akceptowane.

## WYBÓR LOKALIZACJI

Przed rozpoczęciem montażu należy zapoznać się z lokalnymi wymogami prawnymi i przepisami. Podczas wyboru najlepszej lokalizacji na postawienie szklarni należy zwrócić uwagę na to, aby podłoże było równe i stabilne, a także na to, żeby nie było to miejsce odsłonięte, gdzie szklarnia

będzie stała w zupełnie pustej przestrzeni! Musi być zapewnione jakieś zabezpieczenie przed burzami i porywistymi wiatrami. W przypadku braku zabezpieczeń dojdzie do szkód.

## **WSKAZÓWKI DOTYCZĄCE MONTAŻU**

Postępować zgodnie z ilustracjami przedstawiającymi etapy montażu.



Podczas montażu stale nosić rękawice ochronne, długie rękawy i okulary ochronne. Niektóre części mogą mieć ostre krawędzie i spowodować zranienia!

Aby przejść do filmu prezentującego montaż,  
należy zeskanować kod QR.

- Przed postawieniem szklarni konieczne jest odpowiednie przygotowanie fundamentu. Takie fundamenty (pomoce szalunkowe) można zakupić w naszym sklepie internetowym.
- Nie montować szklarni podczas wietrznej pogody lub gdy jest wilgotno.
- Wyjąć części z kartonu i posortować je według numerów. Upewnić się, że w zestawie są wszystkie części potrzebne do montażu.
- Zapoznać się ze sposobem działania wszystkich narzędzi.
- Nie pozwalać dzieciom i zwierzętom domowym na przebywanie w miejscu montażu.
- W przypadku używania drabiny należy dopilnować, aby była ona stabilnie postawiona. Nigdy nie stawać całym ciężarem na jakiegokolwiek części dachu lub szklarni.
- Niektóre czynności montażowe muszą zostać wykonane przez dwie osoby.
- Małe części (śruby itp.) przechowywać w kartonach i torebkach, aby się nie zgubiły.
- Każda część jest ponumerowana, a odpowiadający jej numer można znaleźć w instrukcji montażu.
- Rozpocząć montaż od ułożenia części o tym samym numerze w oddzielnych grupach wokół miejsca montażu.
- Aluminiowa rama szklarni powinna być montowana jako pierwsza, a panele PC są wkładane jako ostatnie.

## **KONSERWACJA I PIELĘGNACJA**

- Do czyszczenia używać gąbki i ciepłej wody z mydłem. Nie stosować środków czyszczących lub myjących zawierających rozpuszczalniki, np. wybielaczy, ponieważ mogą one uszkodzić produkt.
- Do wszystkich prac przy szklarni zawsze używać odpowiednich narzędzi.
- Uszkodzone części szklarni należy natychmiast wymieniać! Ludzie i zwierzęta mogą zranić się uszkodzonymi częściami!
- Koniecznie pamiętać, aby zimą regularnie usuwać śnieg z dachu. Zbyt duża pokrywa śnieżna może spowodować zawalenie się dachu. Już pokrywa śnieżna o grubości przekraczającej 10 cm może być niebezpieczna (grubość warstwy 36 cm dla suchego śniegu, 10 cm dla śniegu z wodą i 5,5 cm dla lodu odpowiada ciężarowi ok. 50 kg/m<sup>2</sup>).
- W przypadku nieprzewidzianych problemów prosimy o kontakt z naszym zespołem serwisowym. Chętnie pomożemy.











## **UTYLIZACJA**

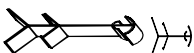

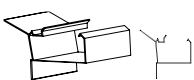
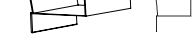



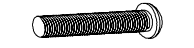
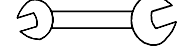



Na końcu długiego okresu żywotności produktu należy odpowiednio zutylizować cenne surowce, tak by możliwy był ich recykling. W razie braku wiedzy, jak to zrobić, można skonsultować się z lokalnymi podmiotami zajmującymi się usuwaniem odpadów lub przetwarzaniem surowców wtórnych.

## LISTA CZĘŚCI (karton 1/2)



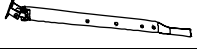

Nr	Rysunek	Ilość	Wymiary (mm)
1		4	1215
2		1	1134
3		1	1134
4		1	1134
5		1	1134
6		1	1647
7		1	1647
8		1	1655
9		1	1655
10		4	1215
11		4	1114
12		1	610
13		4	
14		1	1260
15		1	634
16		2	911
16A		1	170
17		1	1355
17A		1	467
17B		1	170





Nr	Rysunek	Ilość	Wymiary (mm)
18		2	
19		1	380
20		2	1608
21		4	1220
21A		4	610
21B		2	
22		4	1350
22A		2	1362
23		2	594
24		1	610
25		2	1304
26		2	610
27		1	610
28		2	520
29		1	608
30		1	595
31		1	595
32A		2	1432
32B		2	390
32C		2	170

Nr	Rysunek	Ilość	Wymiary (mm)
33		1	1433
33A		1	388
33C		1	170
34A		2	1433
34B		2	390
34C		2	170
35		5	603
36		2	
37		1	
38		1	M5x30
39		2	
40		138	M6x10

Nr	Rysunek	Ilość	Wymiary (mm)
41		14	M5x18
41A		2	M4x18
42		6	M4x8
44A		2	
44B		2	
45A		1	
45B		1	
46		1	
47		162	
48		137	M6
53		44	

## LISTA CZĘŚCI PANELI PC (karton 2/2)

Nr	Rysunek	Ilość	Wymiary (mm)
1		11	605 x 1212
2		5	605 x 1130
3A		2	605 x 455
3B		2	605 x 455
4		1	605 x 585

Nr	Rysunek	Ilość	Wymiary (mm)
5		1	595 x 550
6		1	605 x 675
7		1	605 x 250
8		1	615 x 241
9		2	605 x 602

## WSKAZÓWKI DOTYCZĄCE MONTAŻU PANELI PC



Zdjęcie paneli PC 4 mm

Panele mają białą stronę z folią ochronną bez ochrony przed promieniowaniem UV i zieloną stronę z folią ochronną z ochroną przed promieniowaniem UV. Zielona strona powinna znajdować się na zewnątrz.

Folia chroni panele, dlatego zalecamy usunięcie folii ochronnej dopiero po włożeniu paneli w ramę szklarni, aby wiedzieć, która strona jest chroniona przed promieniowaniem UV i aby strony nie zostały pomylone podczas montażu.

Dobrym sposobem jest usunięcie ok. 5 cm folii ochronnej ze wszystkich krawędzi płyty przed zamontowaniem paneli w aluminiowej ramie (aby folia nie dostała się pod śruby i aluminiowe listwy), a po zamocowaniu paneli w ramie można całkowicie usunąć folie ochronne.

Podczas obchodzenia się z panelami należy zachować szczególną ostrożność, aby nie zarysować ich podczas montażu.

Zalecamy przygotowanie następujących narzędzi do montażu:

- rękawice ochronne
- taśma miernicza
- wkrętak płaski
- wkrętak akumulatorowy

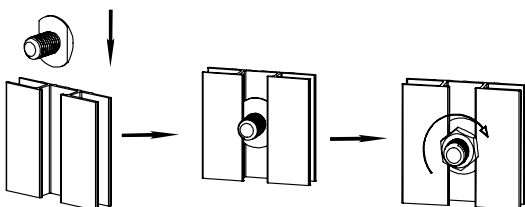

(w opakowaniu znajduje się klucz płaski).





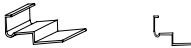

Tak należy wsunąć śruby w rowki aluminiowych listw.

## MONTAŻ OKNA DACHOWEGO

Umieścić części zgodnie z poniższym rysunkiem, włożyć śruby (nr 40) od góry do dołu, najpierw zamontować części 28 i 31, następnie płytę (część 5), a w dalszej kolejności część nr 30.

Nr	Rysunek	Ilość	Wymiary (mm)
28		2	520
30		1	595
31		1	595
40		4	M6x10

Nr	Rysunek	Ilość	Wymiary (mm)
42		2	M4x8
46		1	
48		4	M6
5		1	595 x 550

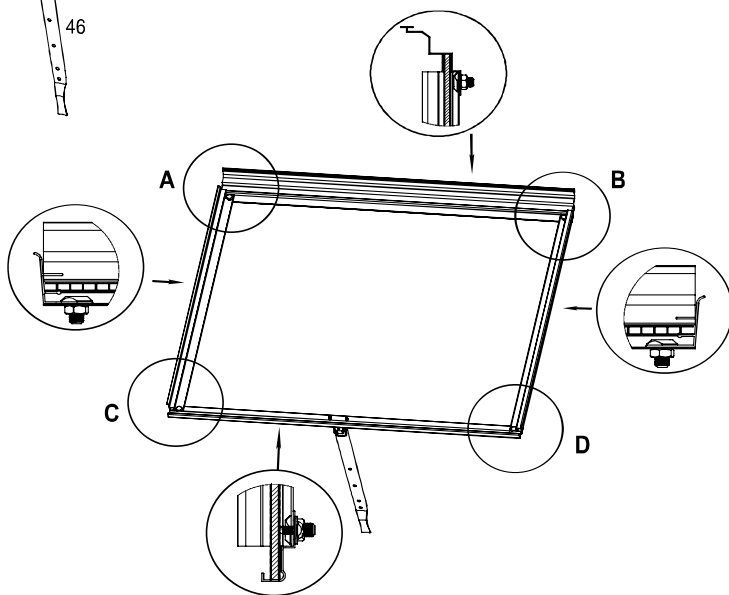
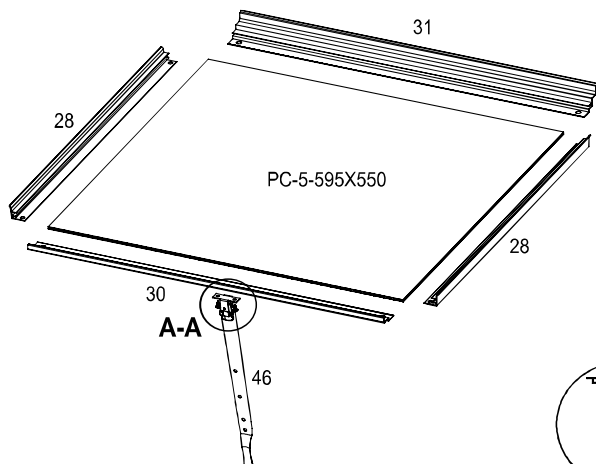

Zielona strona z folią ochronną z ochroną UV powinna być skierowana w stronę słońca. Biała strona z folią ochronną bez ochrony przed promieniowaniem UV powinna być skierowana do wnętrza szklarni.

**AA**

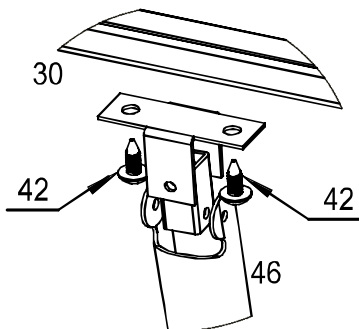

**A**

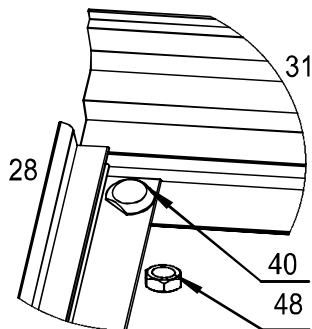

Przymocować uchwyt do specjalnych otworów na śruby.

**B**

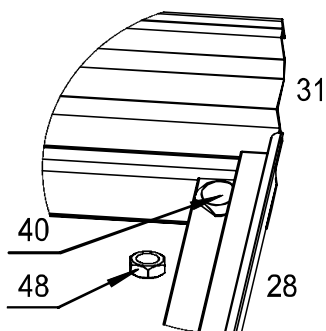

**C**

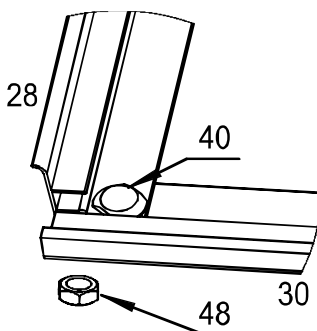

Śrubę i nakrętkę dokręcić dopiero po włożeniu części nr 30 w pozycję śruby.

**D**

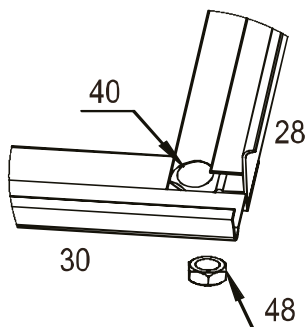

## MONTAŻ RAMY DRZWI PRZESUWNYCH

Nr	Rysunek	Ilość	Wymia ry (mm)
20		2	1608
24		1	610
26		2	610
27		1	610
29		1	608

Nr	Rysunek	Ilość	Wymia ry (mm)
36		2	
40		2	M6x10
41		14	M5x18
41A		2	M4x18
48		2	M4x8

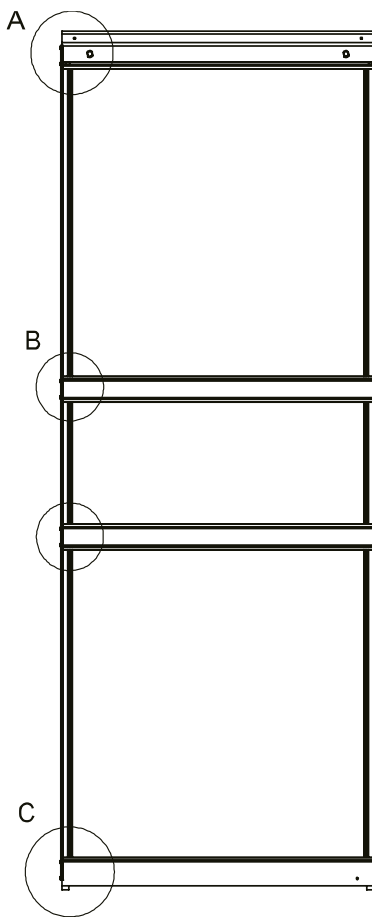
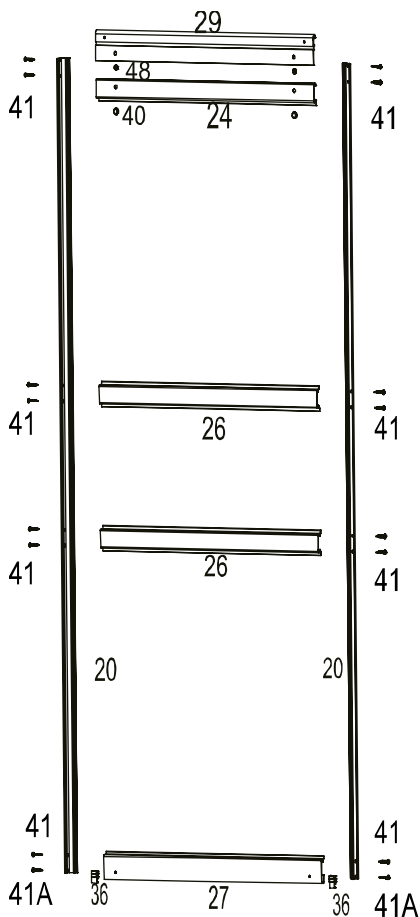

A

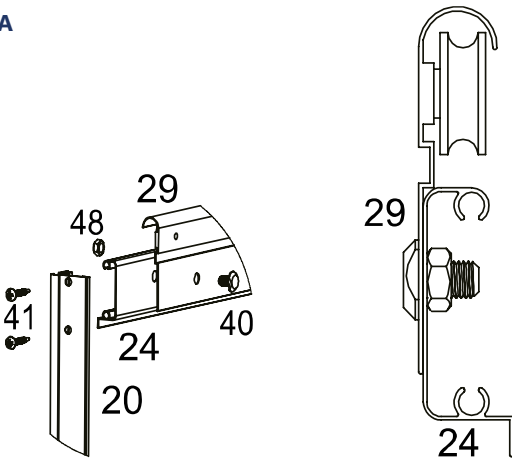

B

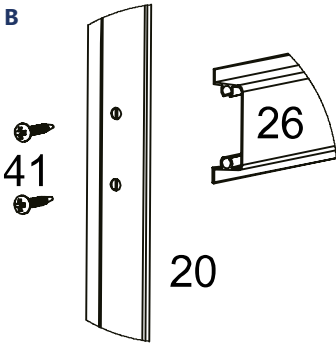

C

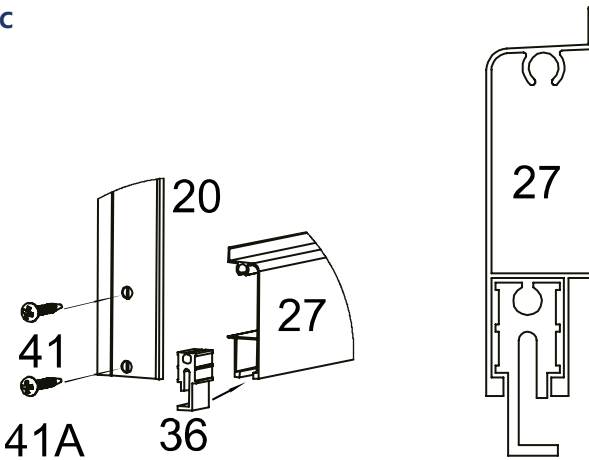

## MONTAŻ RAMY PRZEDNIEJ

Nr	Rysunek	Ilość	Wymia-ry (mm)
1		2	1215
2		1	1134
3		1	1134
6		1	1647
7		1	1647
12		1	610
13		2	
14		1	1260
17		1	1335
17A		1	467

Nr	Rysunek	Ilość	Wymia-ry (mm)
17B		1	170
19		1	380
23		2	594
25		2	1304
37		1	
38		1	
40		26	M6x10
48		27	M6

Podczas montażu prosimy postępować zgodnie ze wskazówkami dla części 2 i części 3.  
Widok ramy przedniej od wewnątrz szklarni (widok poniżej).

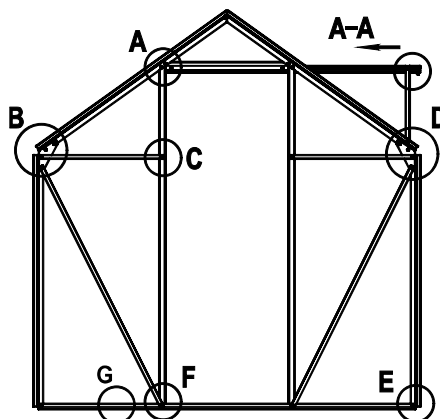
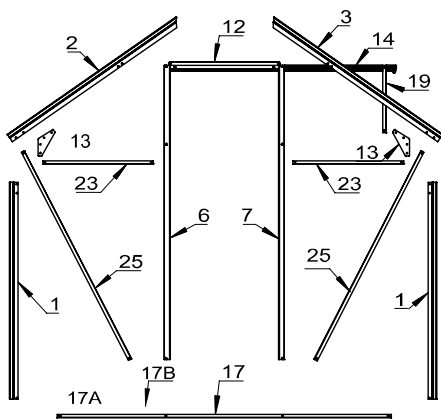

Widok z zewnątrz szklarni.

**AA**

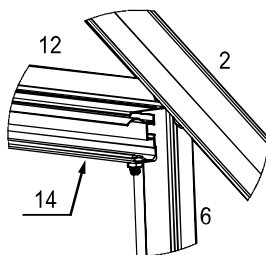
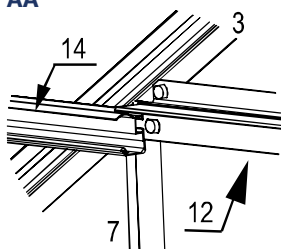

Rysunek po zamontowaniu części nr 14.

**A**

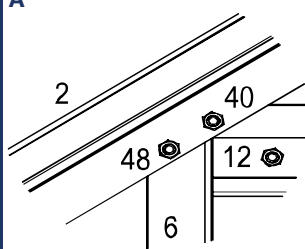

Wycinek A przedstawia wewnętrzną stronę, należy zwrócić uwagę na kierunek montażu części 40 i 48.

**B**

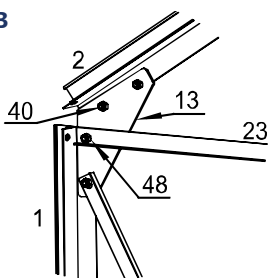

**C**

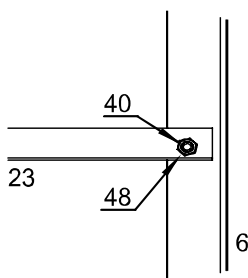

**D**

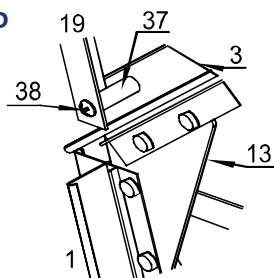

**E**

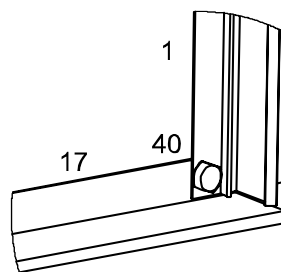

**F**

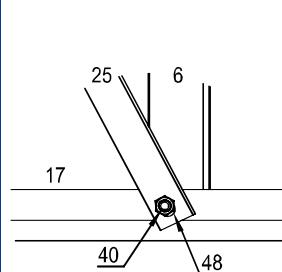

**G**

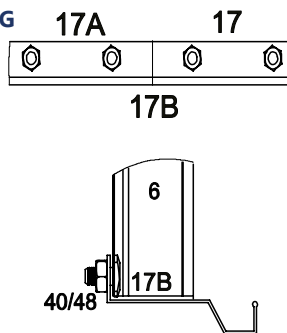

Widok szczegółowy

## MONTAŻ LEWEJ ŚCIANY (widok od strony drzwi)

Nr	Rysunek	Ilość	Wymiary (mm)
10		2	1215
22		2	1304
22A		1	1362
21B		1	
32A		1	1432
32B		1	390
32C		1	170

Nr	Rysunek	Ilość	Wymiary (mm)
34A		1	1433
34B		1	390
34C		1	170
40		18	M6x10
48		18	M6

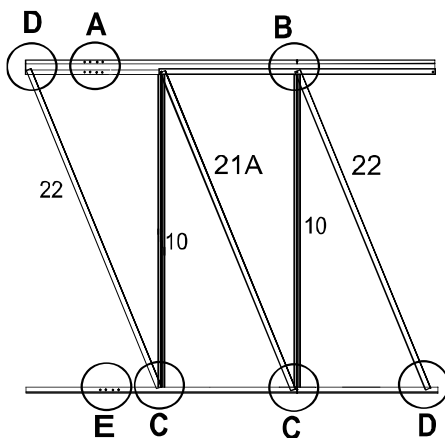
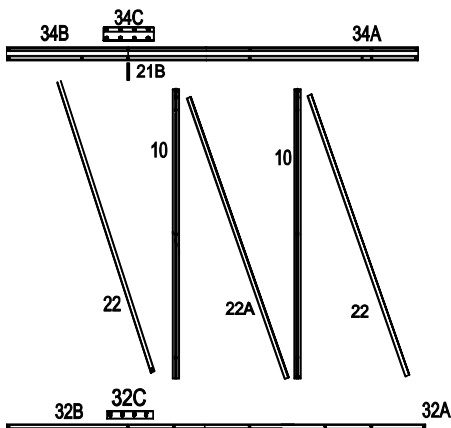

Najpierw zamontować zgodnie z rysunkiem A i E.

Włożyć zawias 21B między 34A/34B w kierunku strzałki i zabezpieczyć za pomocą 34C przy użyciu nakrętek i śrub.

Przed połączeniem części 32 i 34 z częściami 10, 21A i 22, najpierw dokręcić śruby.



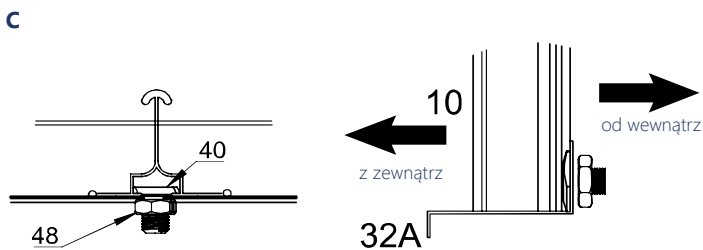
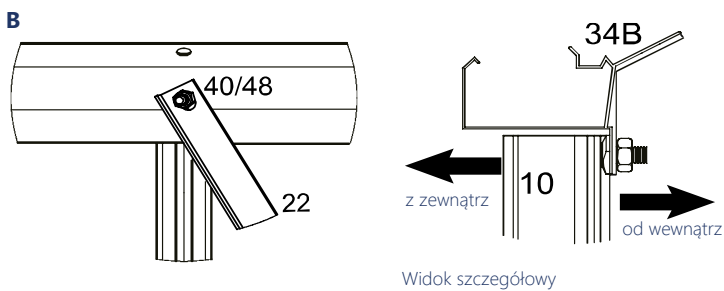
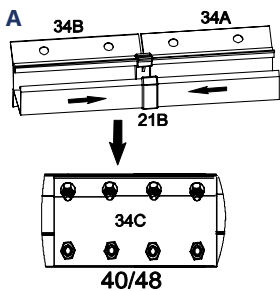

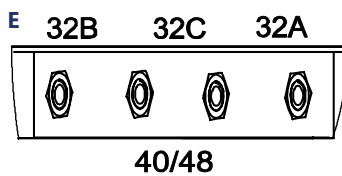
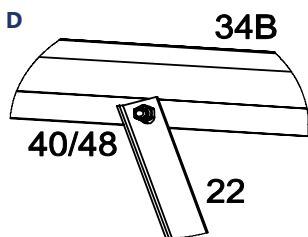

Widok ściany bocznej od wewnątrz.



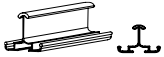
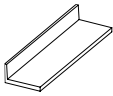



Mocowanie części nr 10 do części 32A

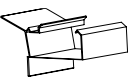

## MONTAŻ PRAWEJ ŚCIANY (widok od strony drzwi)

Nr	Rysunek	Ilość	Wymiary (mm)
10		2	1215
22		2	1304
22A		1	1362
21B		1	
32A		1	1432
32B		1	996
32C		1	170

Nr	Rysunek	Ilość	Wymiary (mm)
34A		1	1433
34B		1	390
34C		1	170
40		18	M6x10
48		18	M6

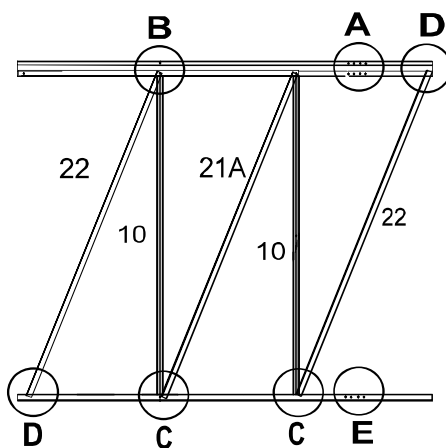
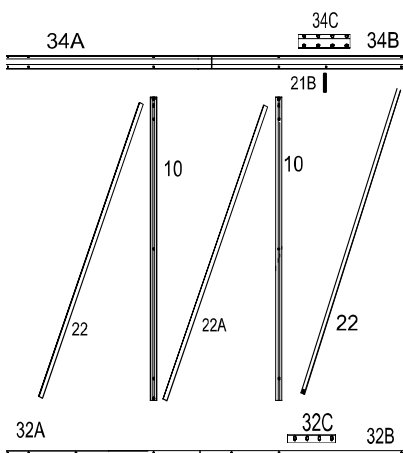

Najpierw zamontować zgodnie z rysunkiem A i E.

Włożyć zawias 21B między 34A/34B w kierunku strzałki i zabezpieczyć za pomocą 34C przy użyciu nakrętek i śrub.

Przed połączeniem części 32 i 34 z częściami 10, 21A i 22, najpierw dokręcić śruby.

Widok ściany bocznej od wewnątrz.

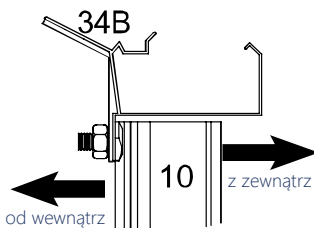
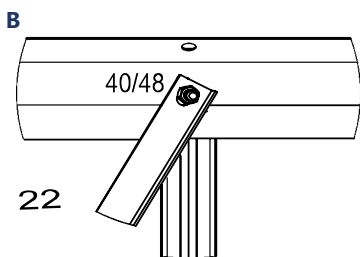
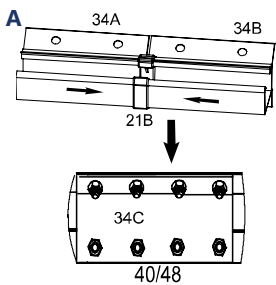

Widok szczegółowy

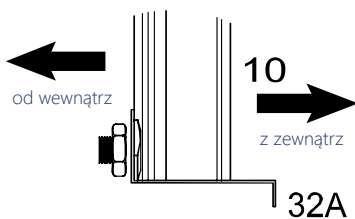
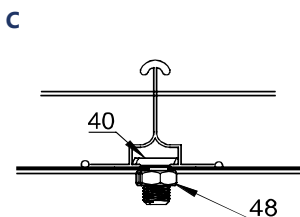

Mocowanie części nr 10 do części 32A

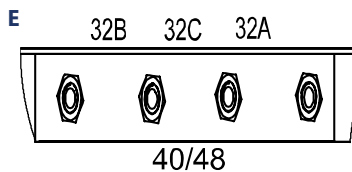
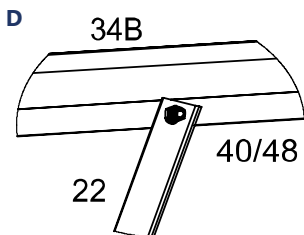

## MONTAŻ RAMY ŚCIANY TYLNEJ

Nr	Rysunek	Ilość	Wymia- ry (mm)
1		2	1215
4		1	1134
5		1	1134
8		1	1655
9		1	1655
13		2	

Nr	Rysunek	Ilość	Wymia- ry (mm)
16		2	911
16A		1	170
21		2	1220
21A		2	610
40		24	M6x10
48		24	M6

Widok ściany tylnej od wewnątrz

Śruby są zabezpieczone od wewnątrz nakrętkami

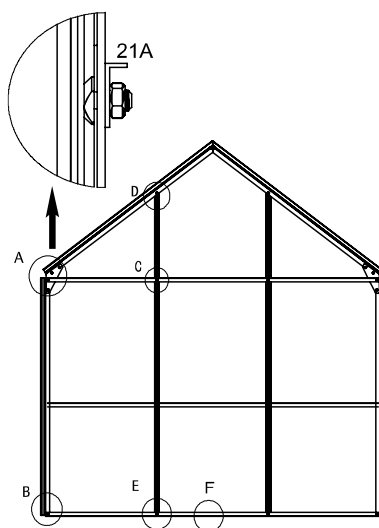
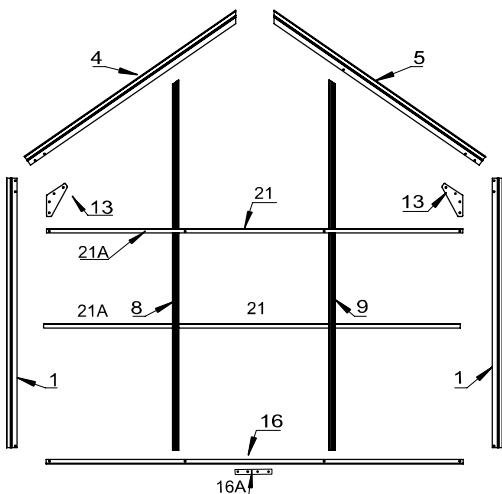

Dokręcić śruby i nakrętki dla widoku C i E

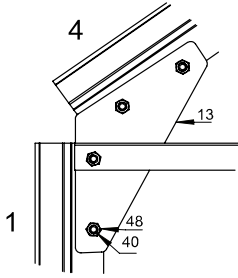
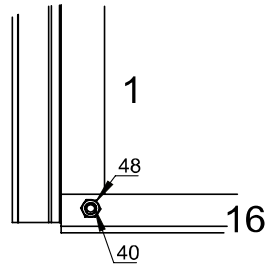
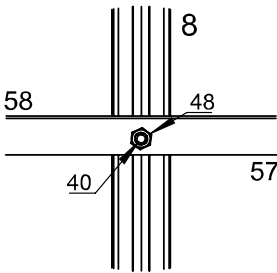
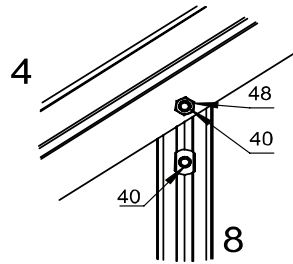
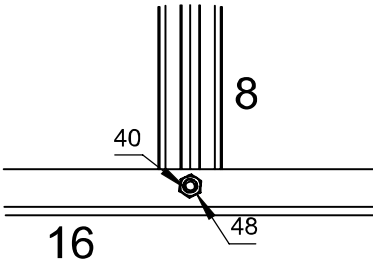
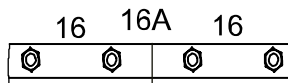
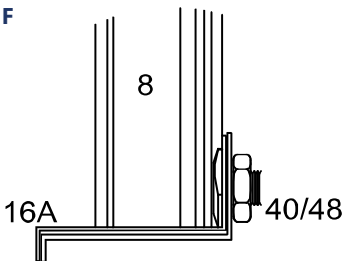

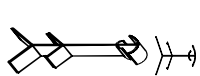
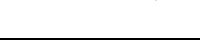

**A****B****C****D****E****F**

Widok szczegółowy

## ŁĄCZENIE RAM ŚCIAN

Nr	Rysunek	Ilość	Wymiary (mm)
33		1	1433
33A		1	388
33C		1	170

Nr	Rysunek	Ilość	Wymiary (mm)
40		24	M6x10
48		24	M6

Do połączenia elementów ramy potrzebne są co najmniej 2-3 osoby.

Należy zwrócić uwagę na rozmieszczenie profili aluminiowych poniżej i użycie śrub do mocowania.

Po zakończeniu montażu ram ściennych należy zmontować grzbiet dachu część nr 33.



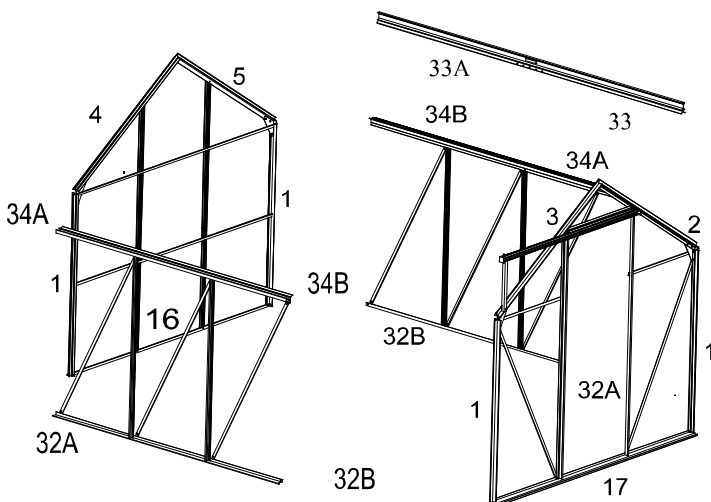
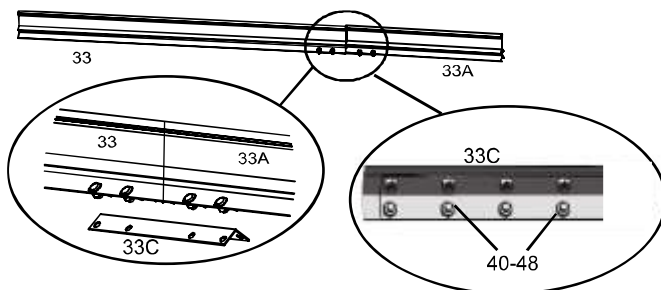

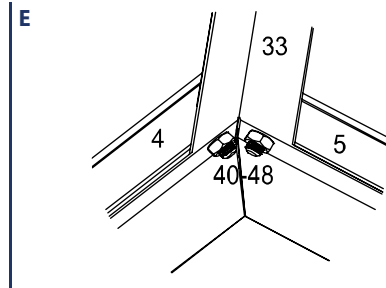
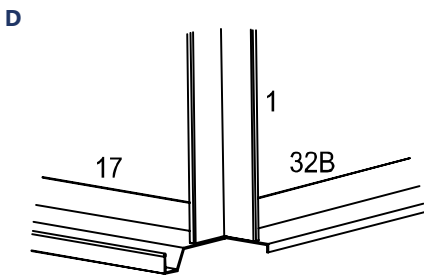
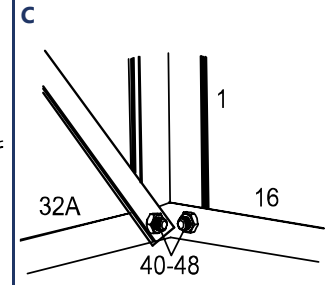
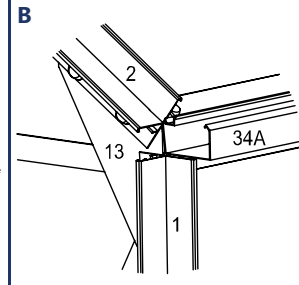
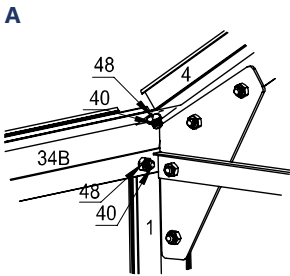
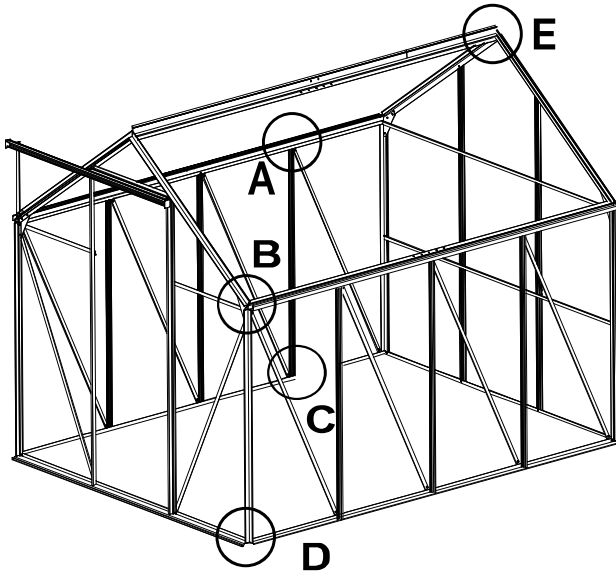
Ostateczną stabilność szklarni uzyskuje się po dokręceniu wszystkich śrub w aluminiowej ramie i po zamontowaniu paneli.



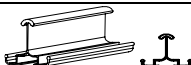
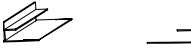
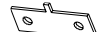
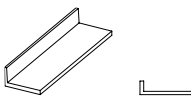

## MONTAŻ RAMY DACHOWEJ

Nr	Rysunek	Ilość	Wymia- ry (mm)
11		4	1114
15		1	634
18		2	
21		2	1220
21A		2	610





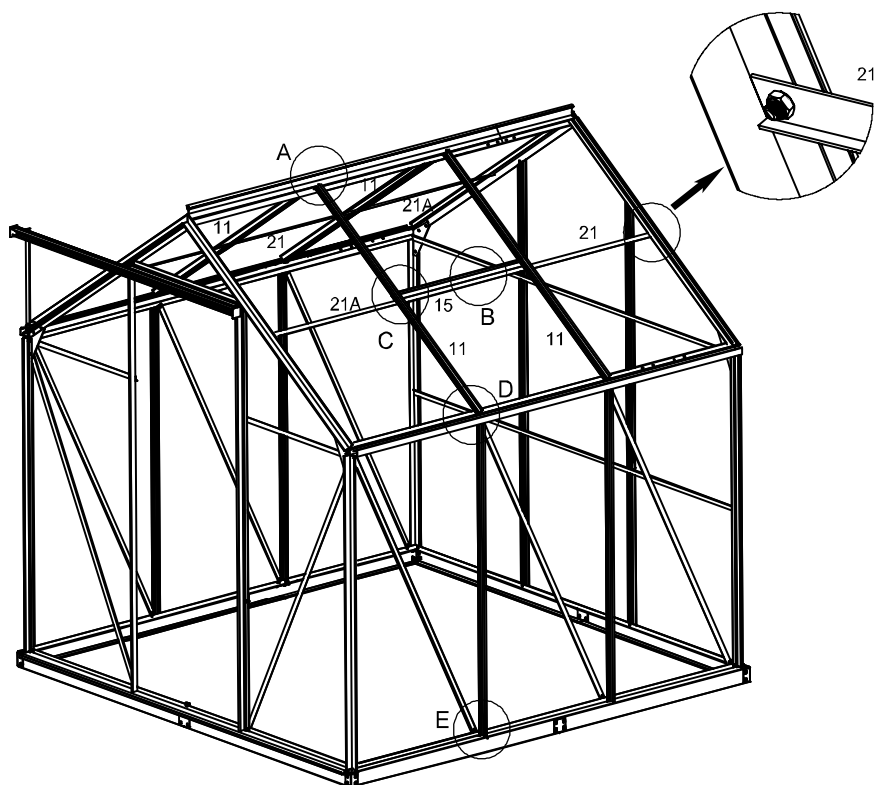

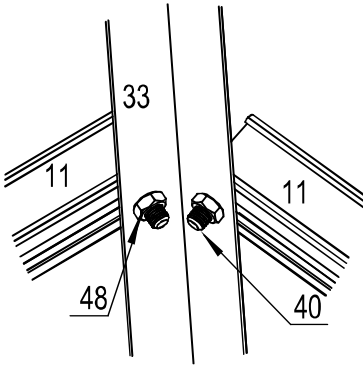
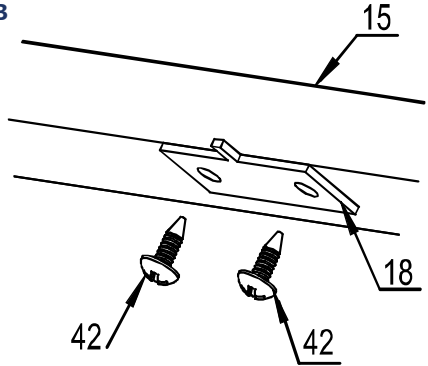
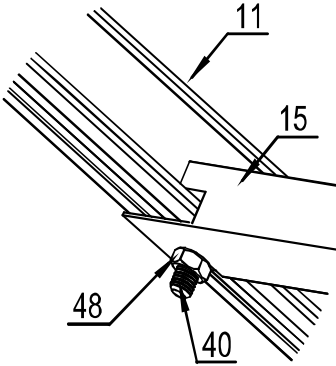
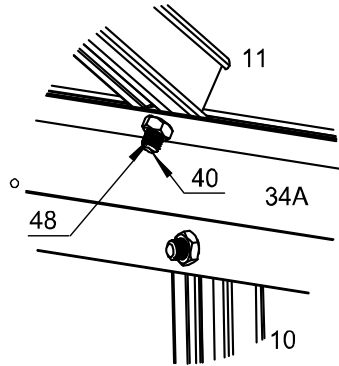
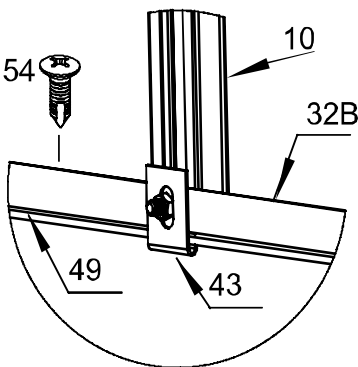
Nr	Rysunek	Ilość	Wymia- ry (mm)
40		18	M6x10
42		4	M4x18
43		16	
48		18	M6
54		16	







Część 43 jest potrzebna do połączenia podłogi szklanej z fundamentem.



**A****B****C****D****E**

## MOCOWANIE PRZEZROCZYSTYCH PANELI PC

Nr	Rysunek	Ilość	Wymiary (mm)
1		11	605 x 1212
2		5	605 x 1130
3A		2	605 x 455
3B		2	605 x 455
4		1	605 x 585
5		1	595 x 550
6		1	605 x 675

Nr	Rysunek	Ilość	Wymiary (mm)
7		1	605 x 250
8		1	615 x 241
9		2	605 x 602
35		5	
47		162	
53		44	

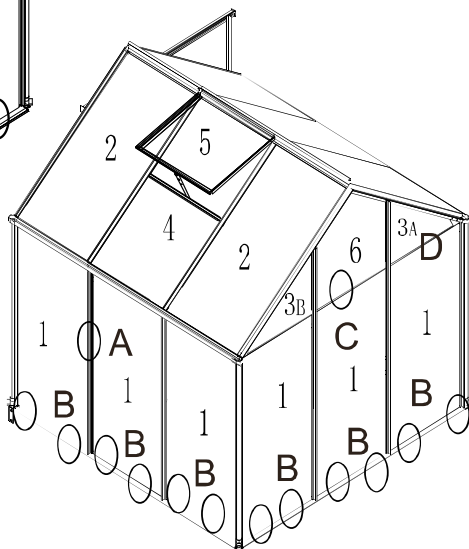
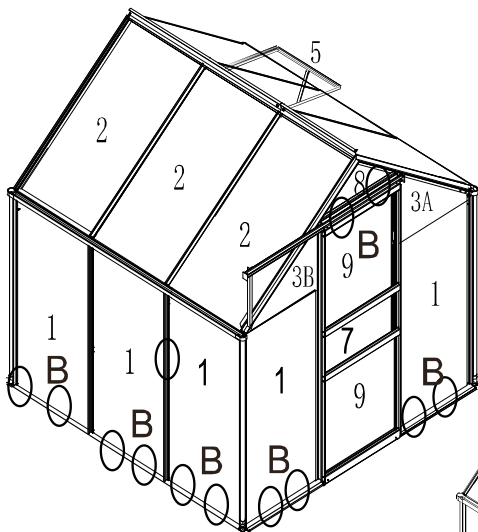

A



B

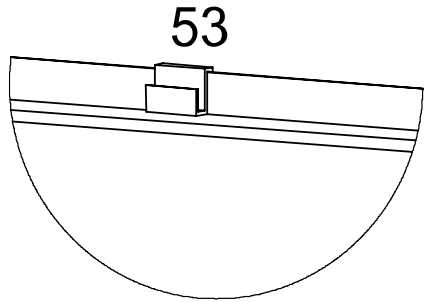

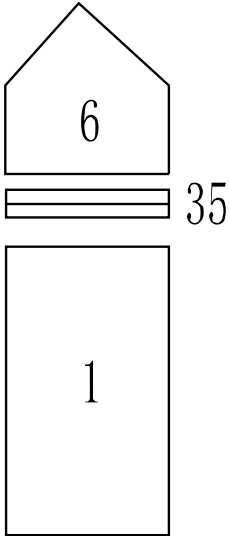

C

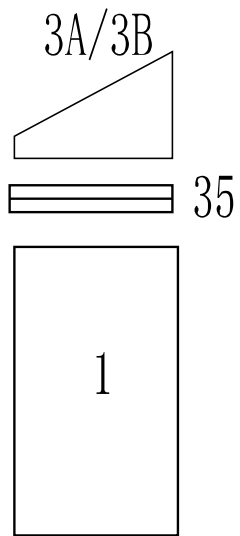

D



## MONTAŻ DRZWI PRZESUWNYCH I RYNNY DESZCZOWEJ

Nr	Rysunek	Ilość	Wymiary (mm)
44A		2	
44B		2	
45A		1	

Nr	Rysunek	Ilość	Wymiary (mm)
45B		1	
40		2	M6x10
48		2	M6

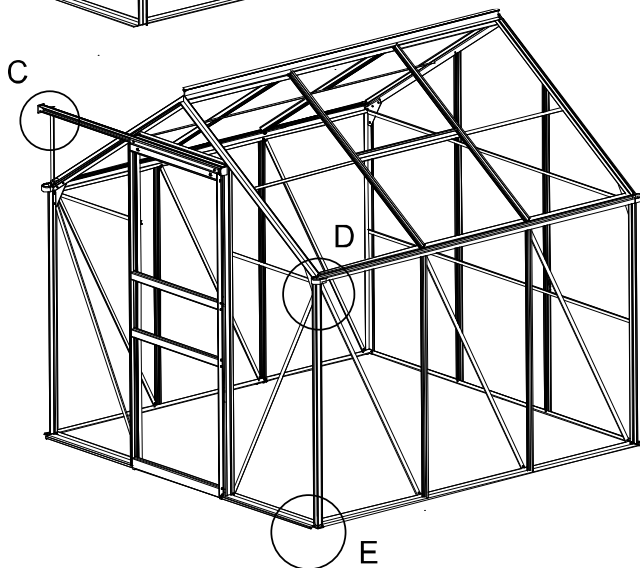
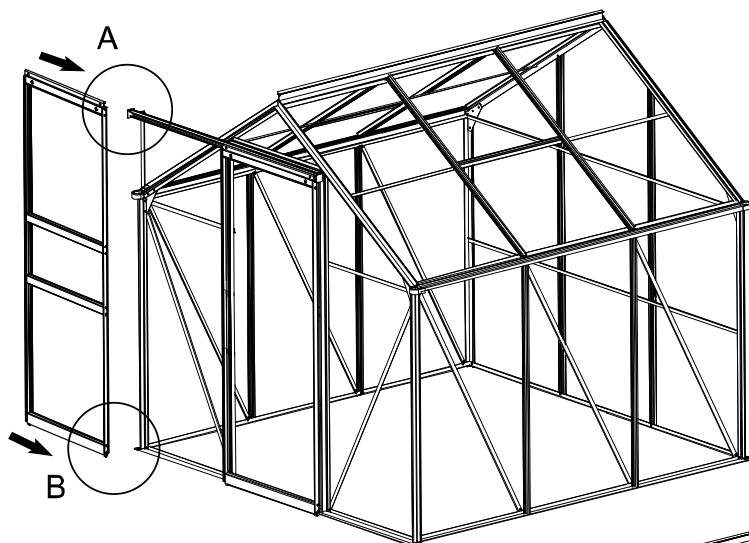

A

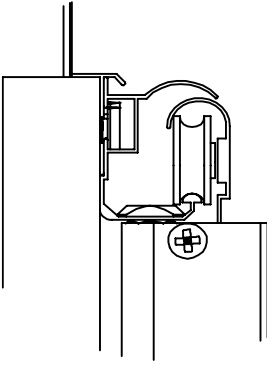

B

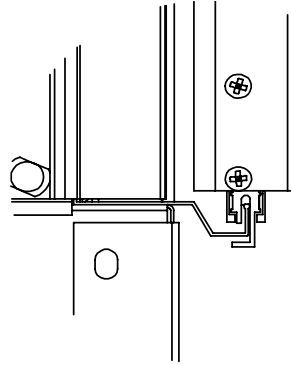

C

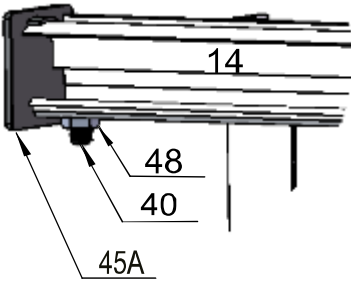

D

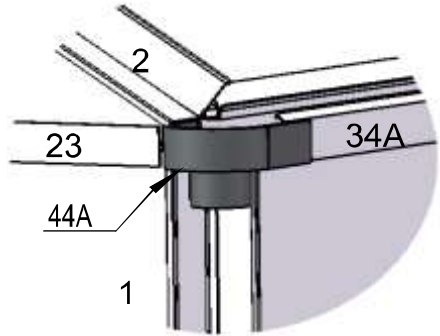

E

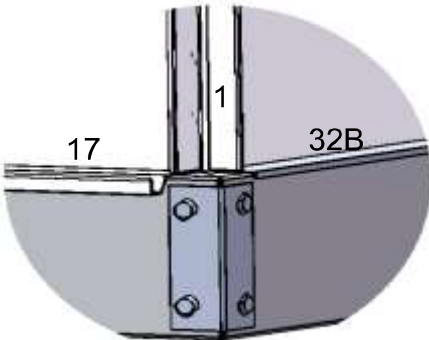

# SERVICEPORTAL

## **DE**

Für jede Art Service, Reklamationen und technischen Support können Sie sich vertrauensvoll an unsere geschulten Mitarbeiter wenden.

## **EN**

For any kind of service, complaints and technical support, you can confidently turn to our trained staff.

## **FR**

Pour tout type de service, réclamations et assistance technique, vous pouvez vous adresser en toute confiance à notre personnel qualifié.

## **IT**

Per qualsiasi tipo di servizio, reclami e supporto tecnico, puoi rivolgerti con fiducia al nostro personale qualificato.

## **ES**

Para cualquier tipo de servicio, quejas y soporte técnico, puede contactar con confianza a nuestro personal capacitado.

## **NL**

U kunt bij ons geschoolde personeel terecht voor elke vorm van service, klachten en technische ondersteuning.

## **PL**

Przy serwisowaniu, reklamacjach i wsparciu technicznym mogą Państwo liczyć na naszych przeszkolonych pracowników.