

ASSEMBLY INSTRUCTION

Folding Bed

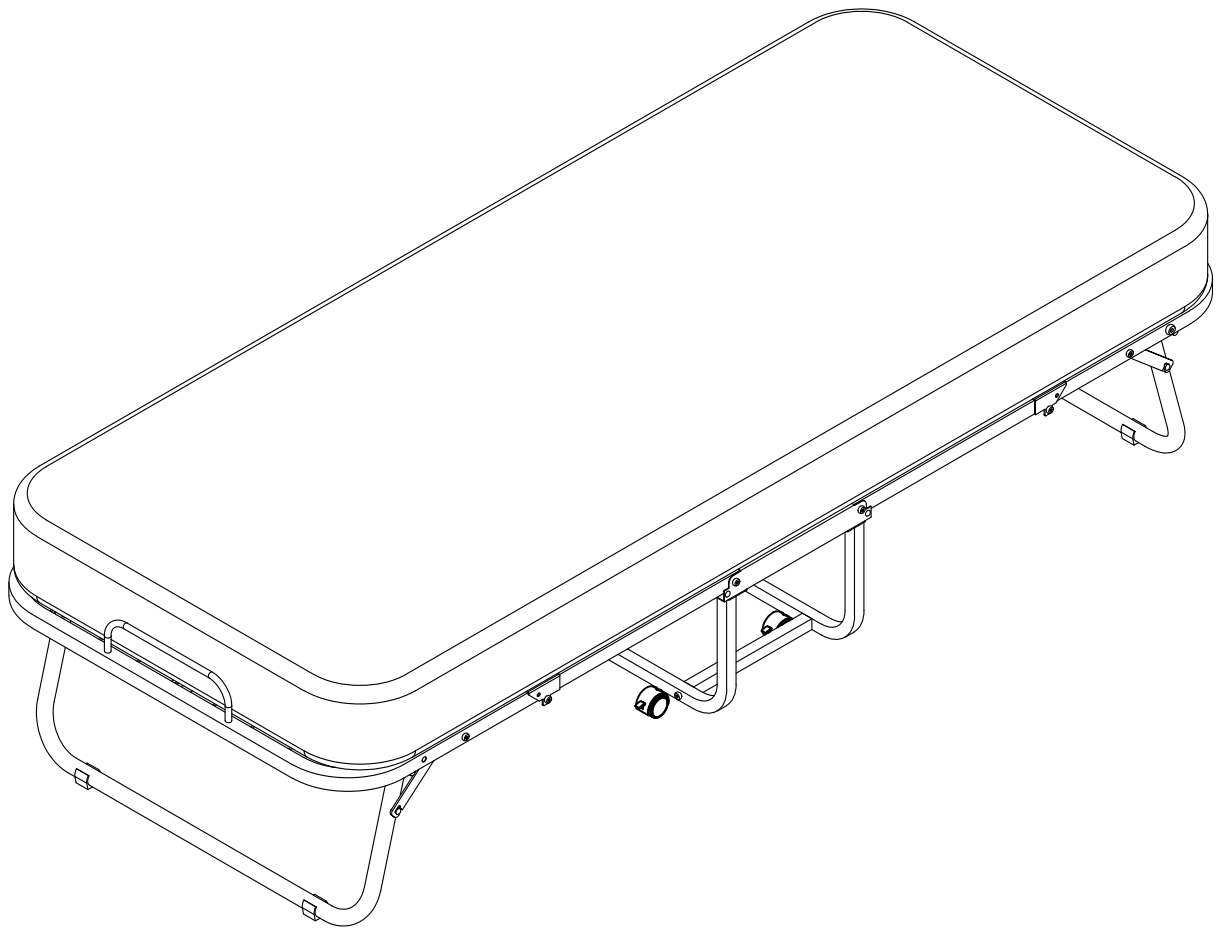

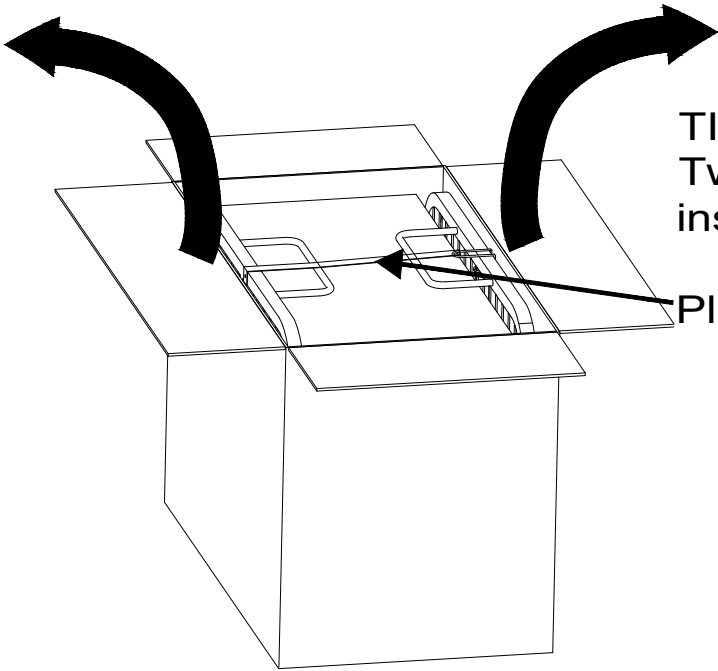

TIP :
Two people are required to
install the folding bed .

Please do NOT pull the strap .

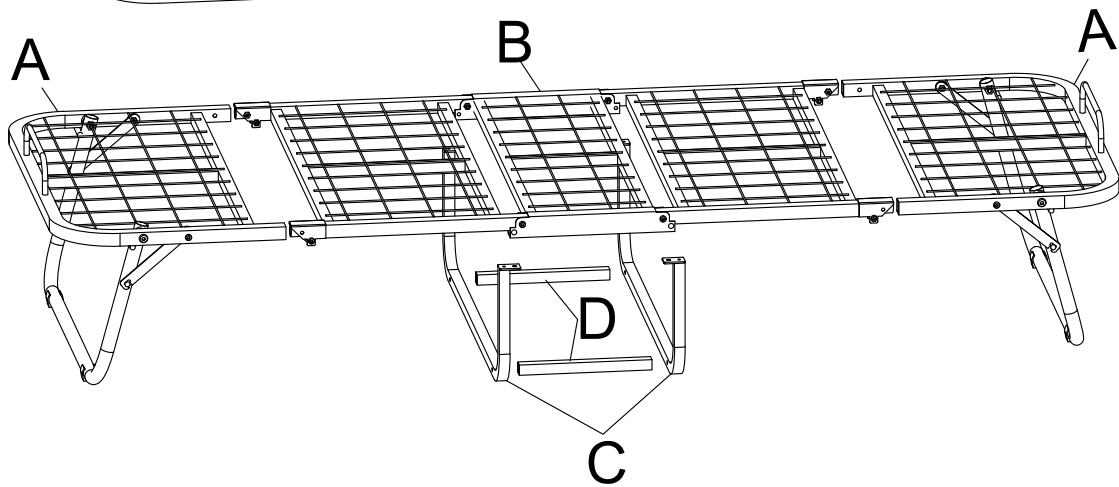
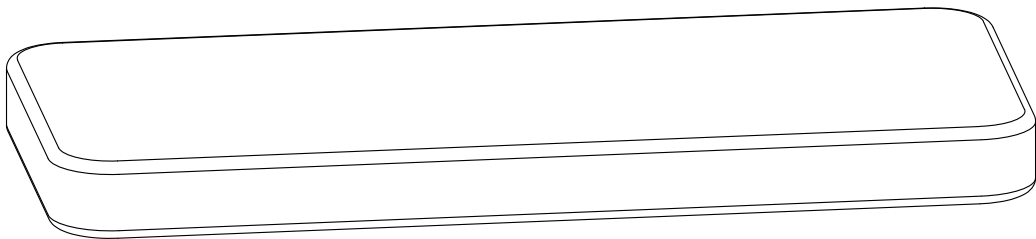

Part List

Mattress

Open packing bag, leave the mattress to expand. Sometimes it only takes a few hours, but other times it can take up to 48 hours to fully expand.

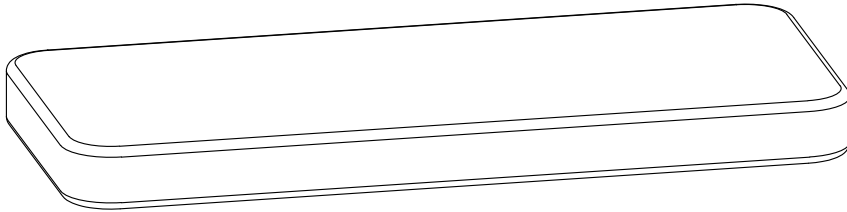

Mattress recovery schedule

Recovery time	Recovery ratio
1 hour	90%
3 hours	94%
24 hours	97%
48 hours	98%

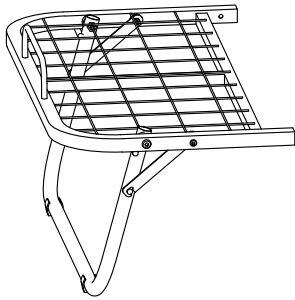

A x 2

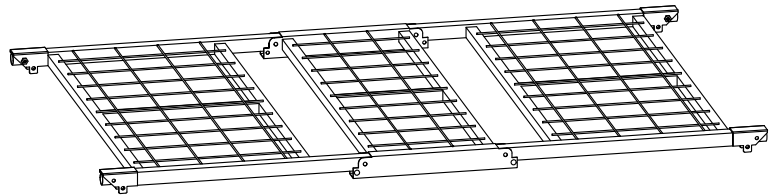

B x 1

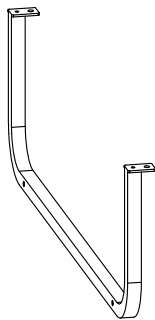

C x 2



D x 2

① x 2

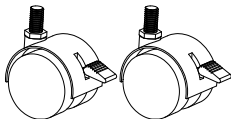

② x 2

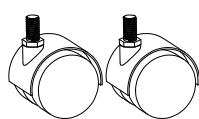

③ x 4

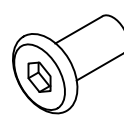

④ x 8



M6x12

⑤ x 4

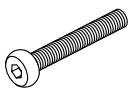

M6x40

⑥ x 1



13#

⑦ x 1

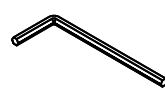

5mm Allen Key

Step 1

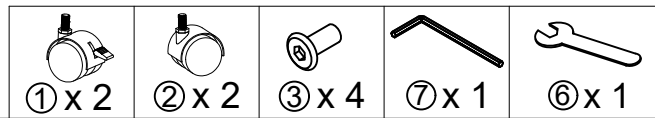
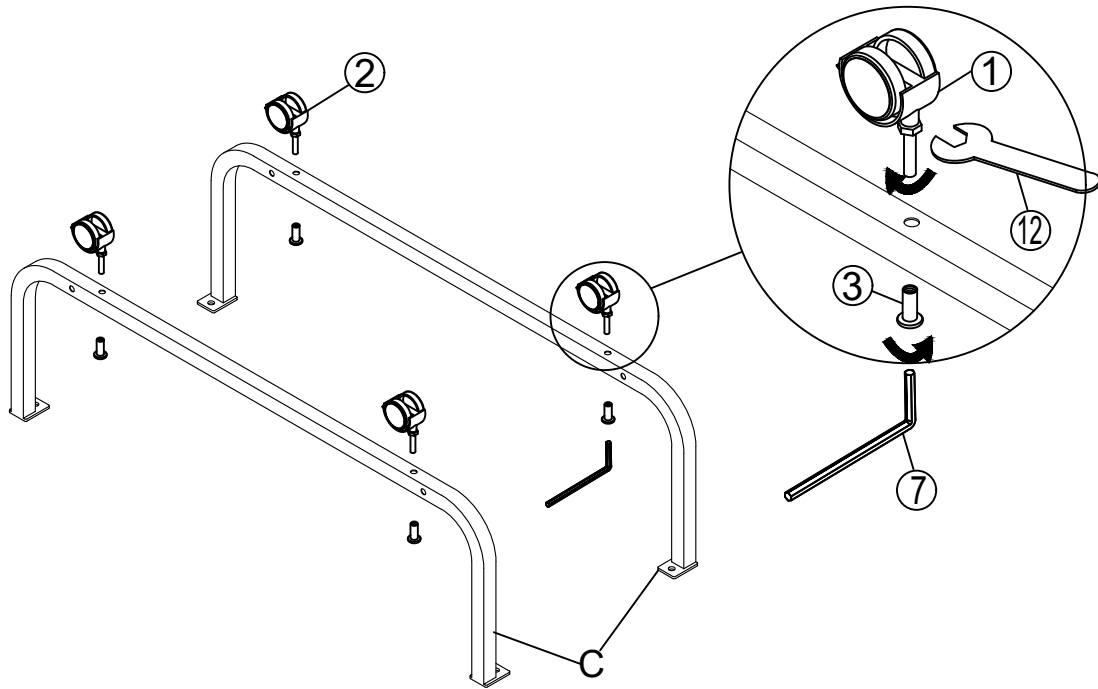

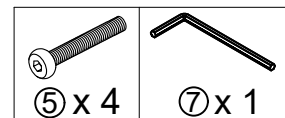
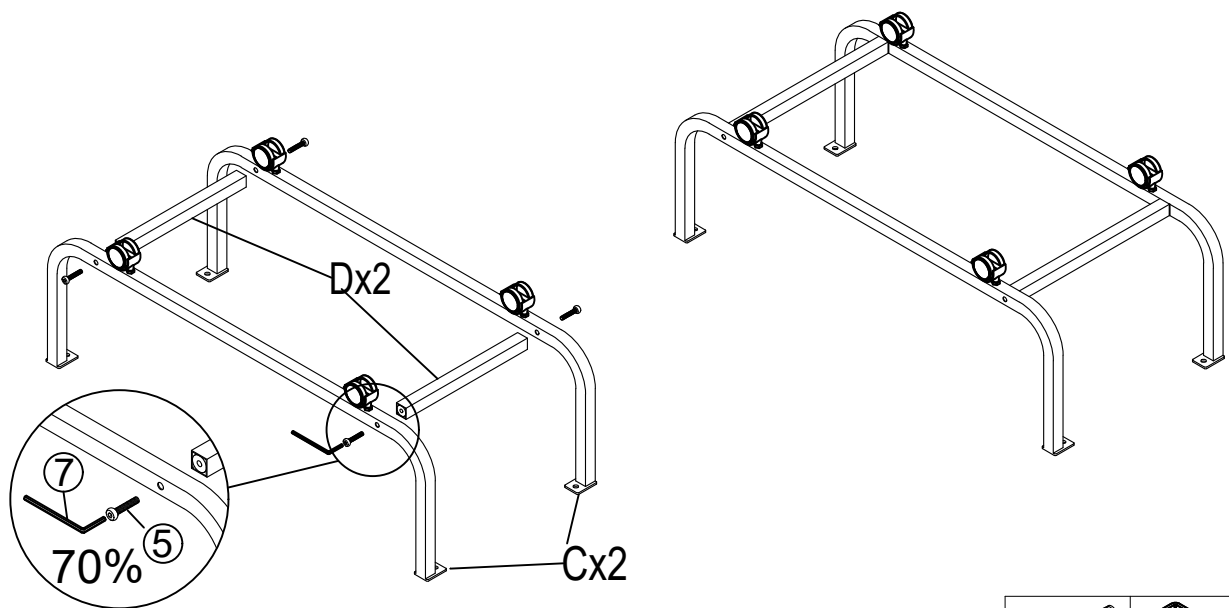

Step 2

Note: Please don't tighten the screws in Step 1, after aligning all of the holes on the frame(Step 2), then tighten all the screws.

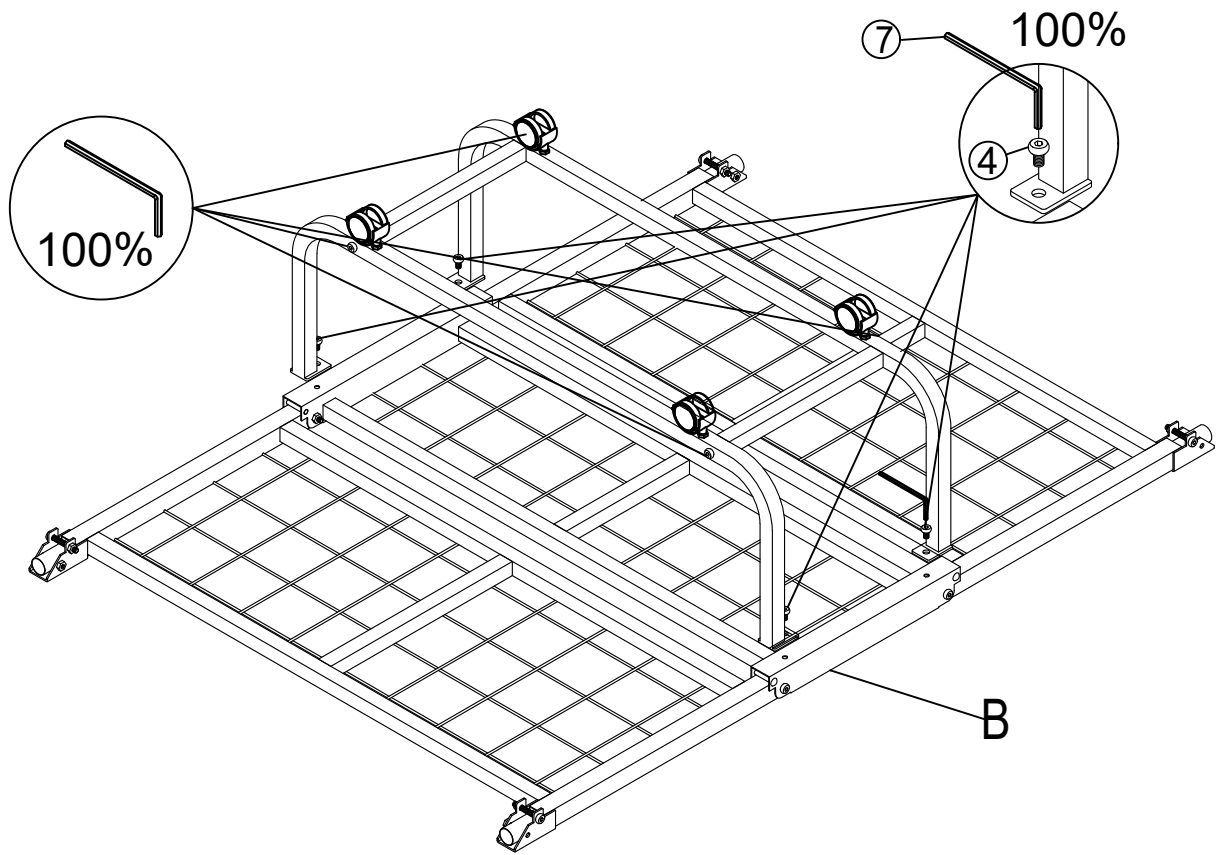

Step 3

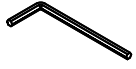

	
④ x 4	⑦ x 1

Step 4

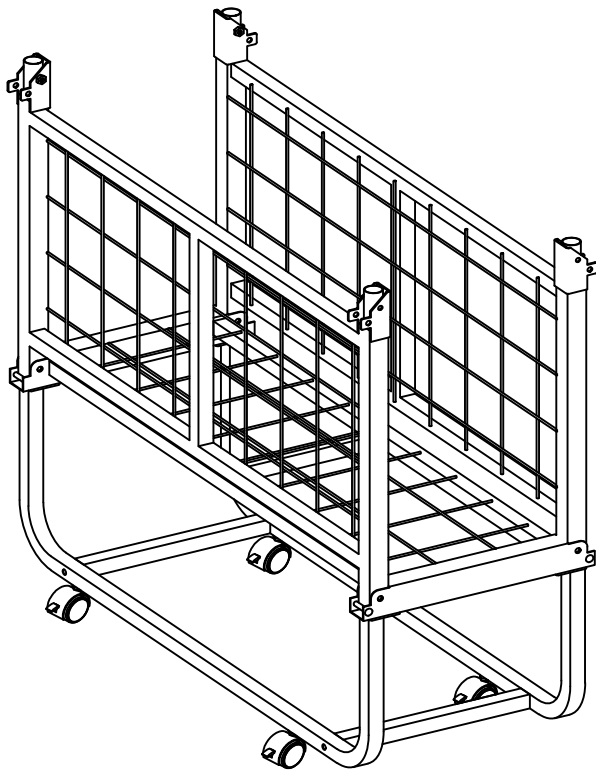
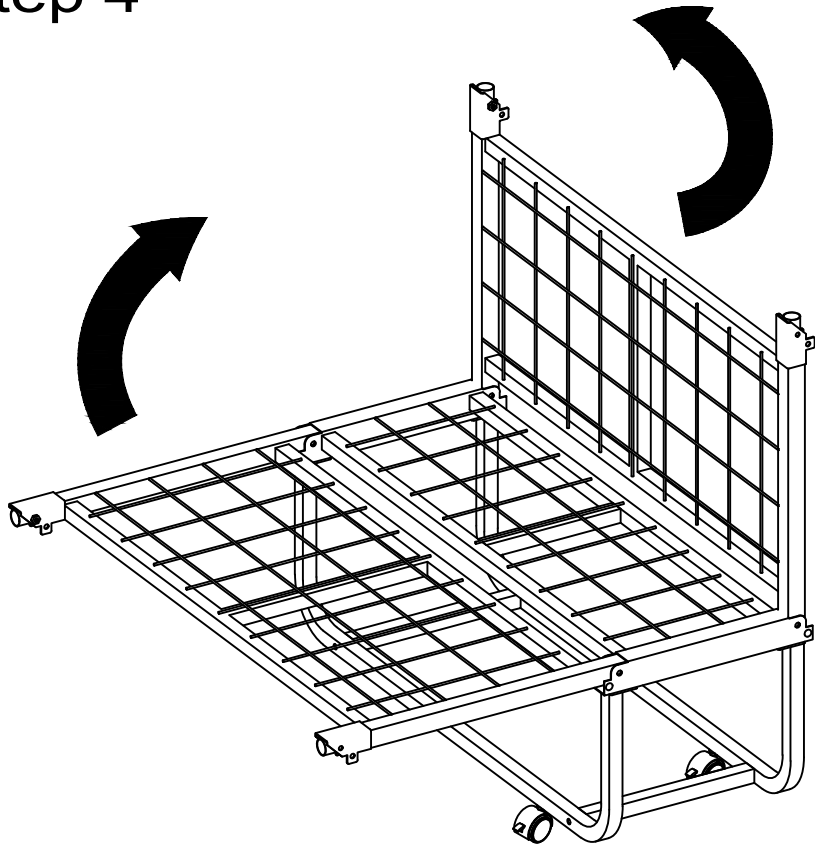

Step 5

When installing part A , please insert it as far as it can , and tighten the screws as below enlarged image .

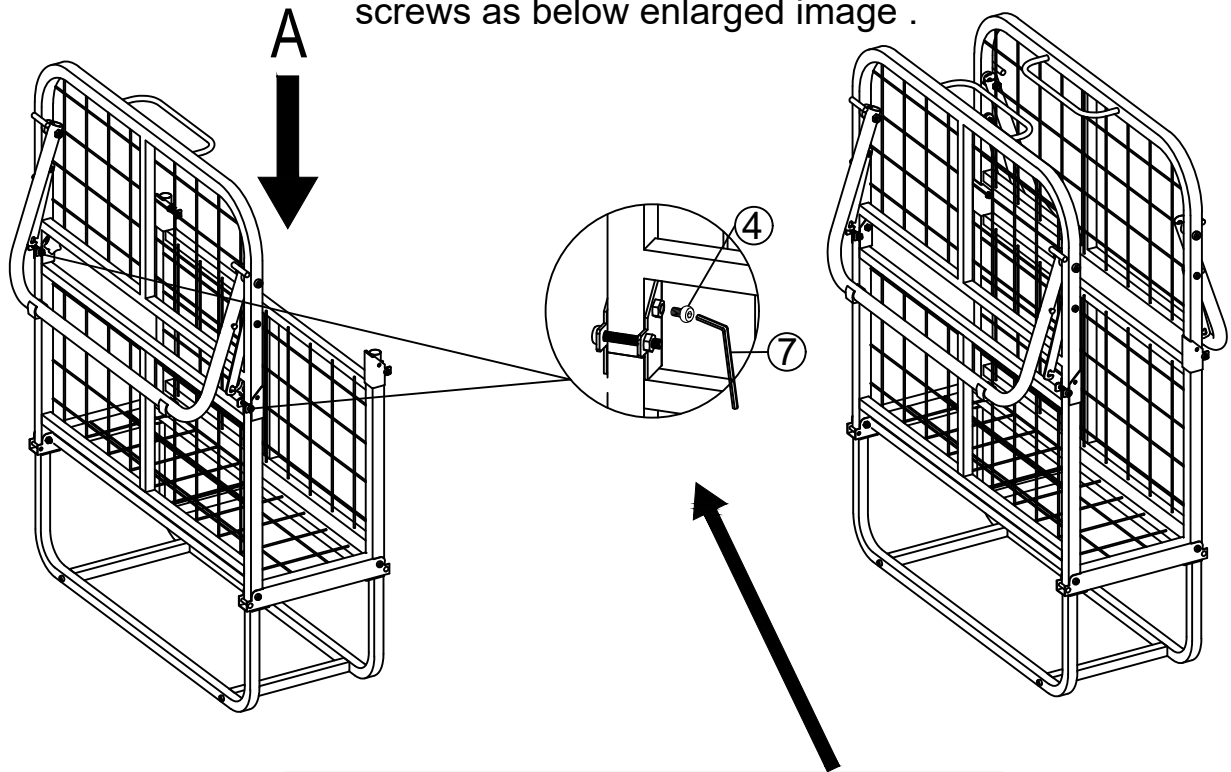

If part A can't be inserted successfully, please loosen the bolt as shown in the picture.

I

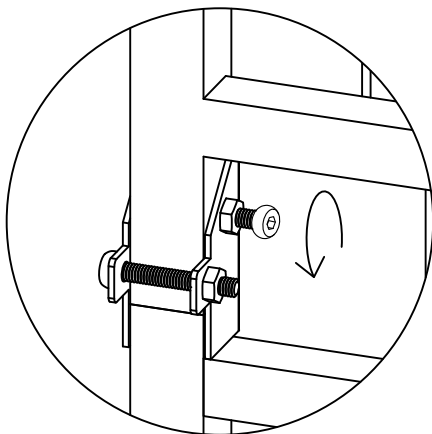

II

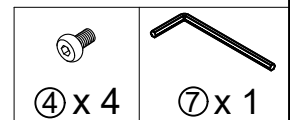
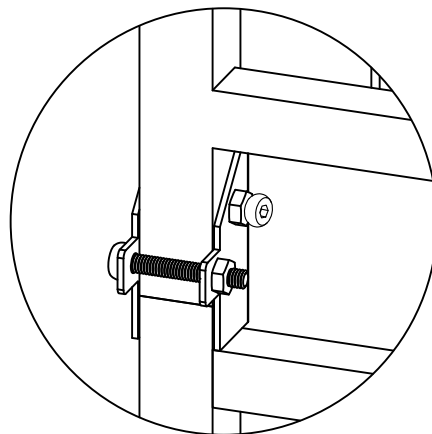

Step 6

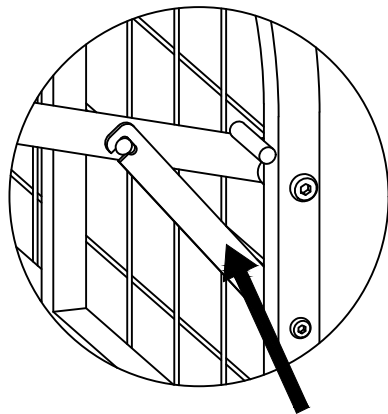
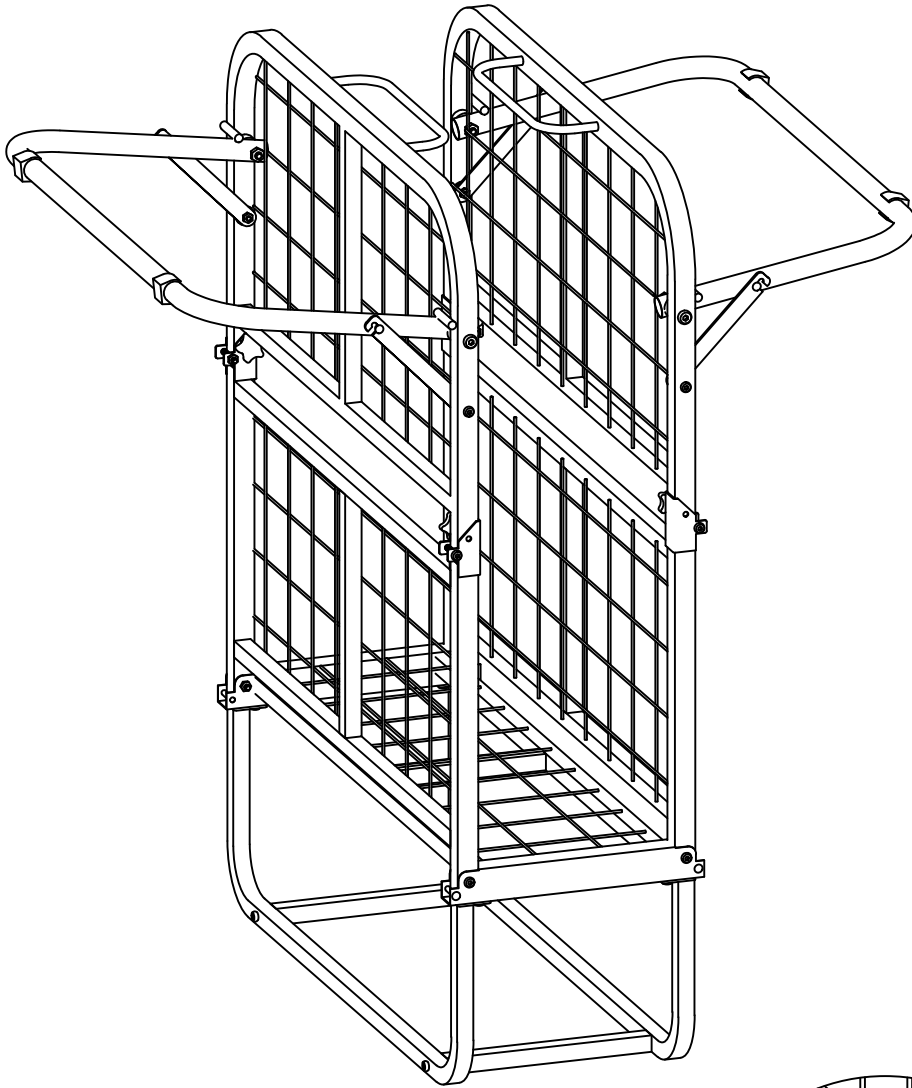

 **CAUTION**

This step is necessary .
Otherwise it will cause component
deformation .

Step 7

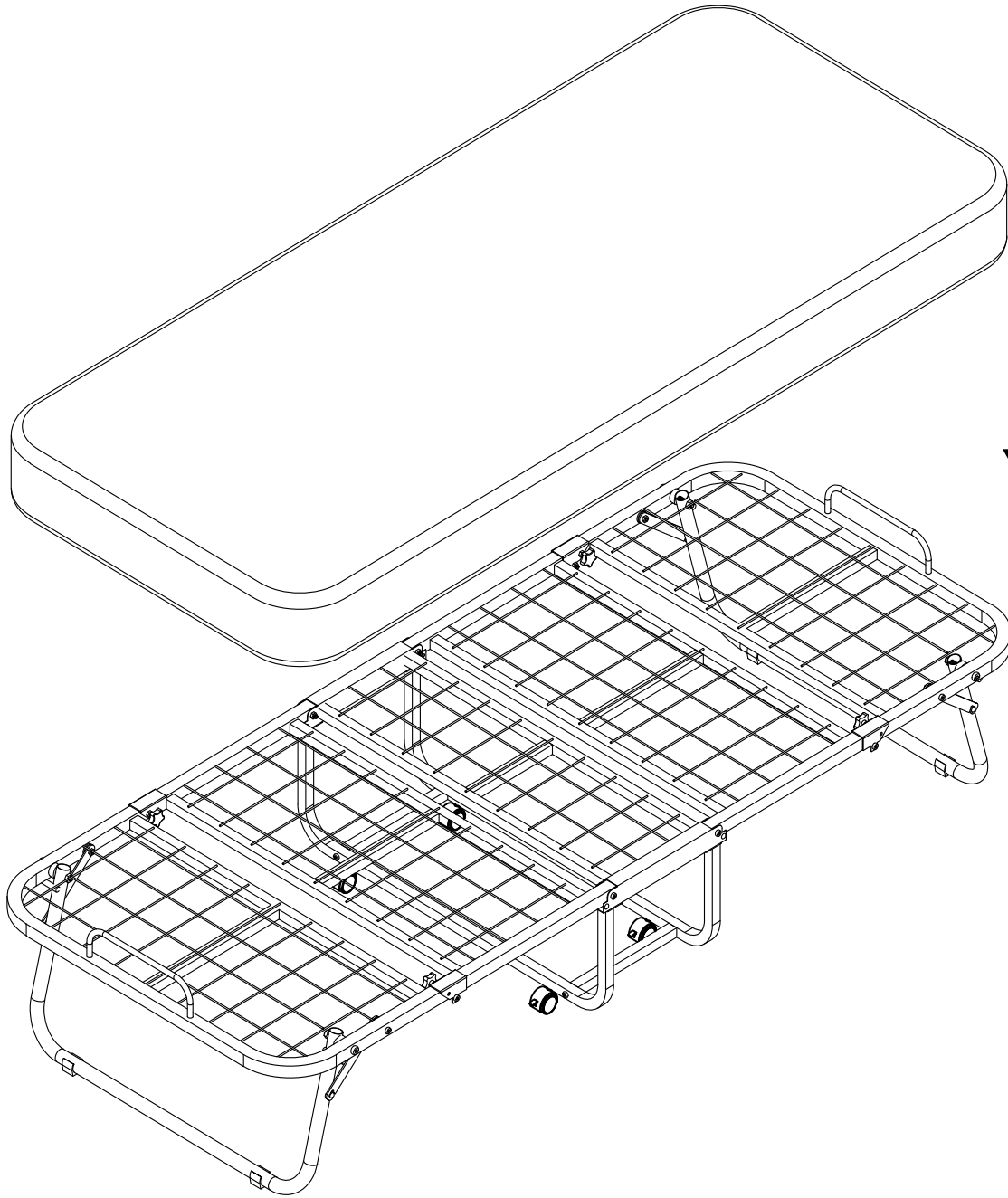

Step 8

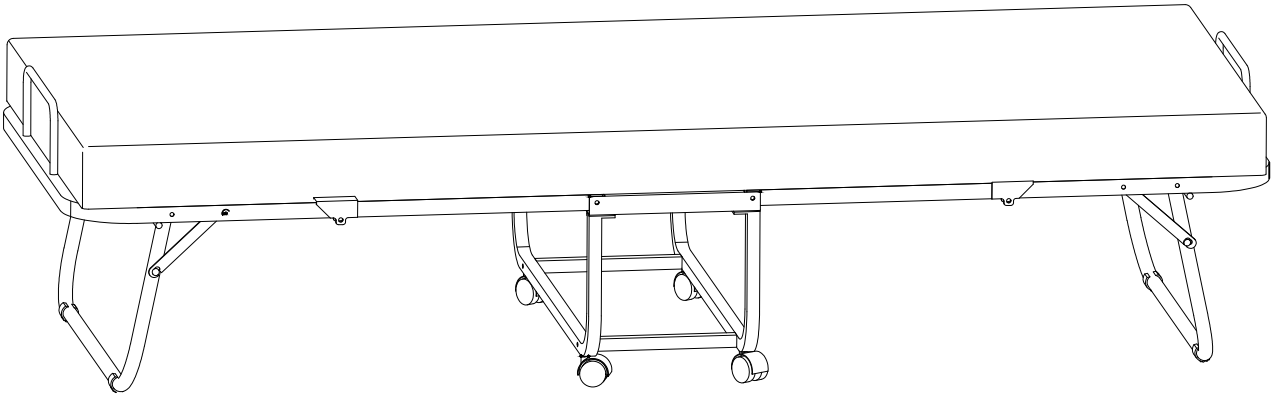

Step 9

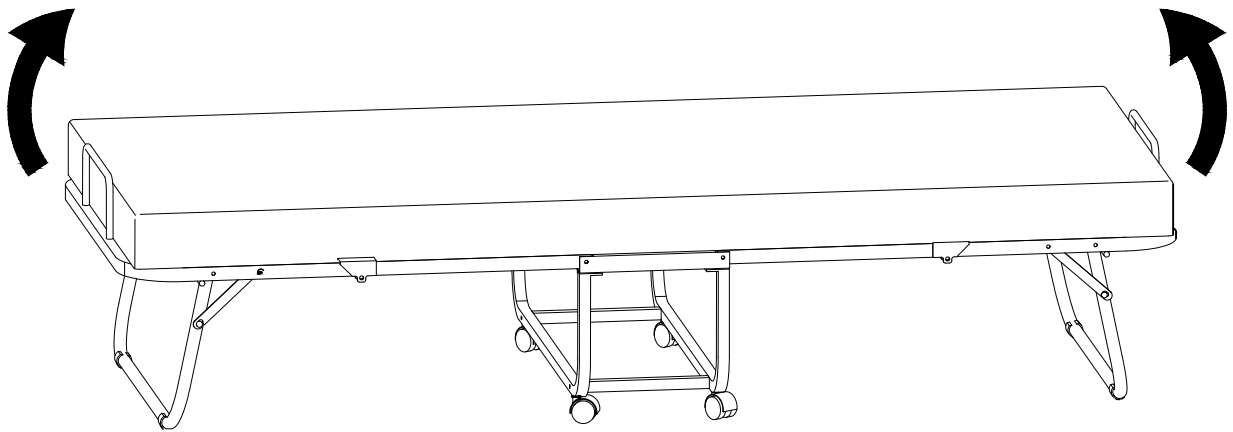

When moving the folding bed ,
please do NOT pull the strap .

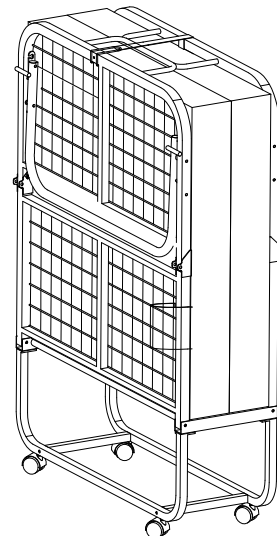
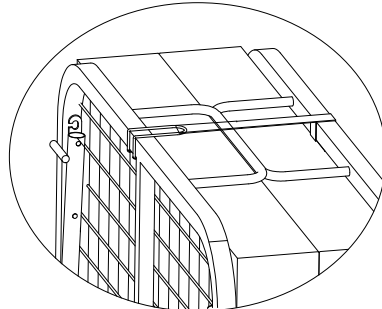
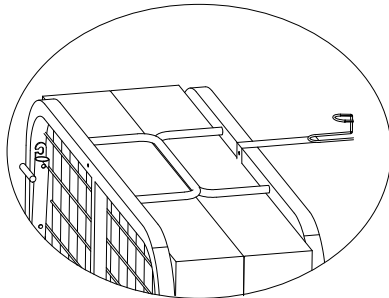
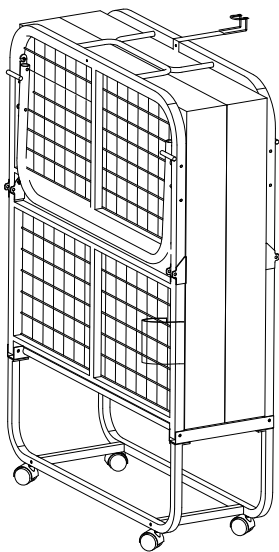

Tips:

1. The modular sofa maybe comes in different boxes, might be delivered at different times.
Please wait several days patiently.
2. Due to differences of light effects, the actual color of the materials might be slightly different from the pictures.
3. Due to package compression for better shipment, the fabric may have wrinkles.
4. Please take all packages out and pat every part to make it rebound better and fluffy, so that it can restore to picture-like status.
5. Please keep plastic bags away from children.
6. Please keep away from fire.

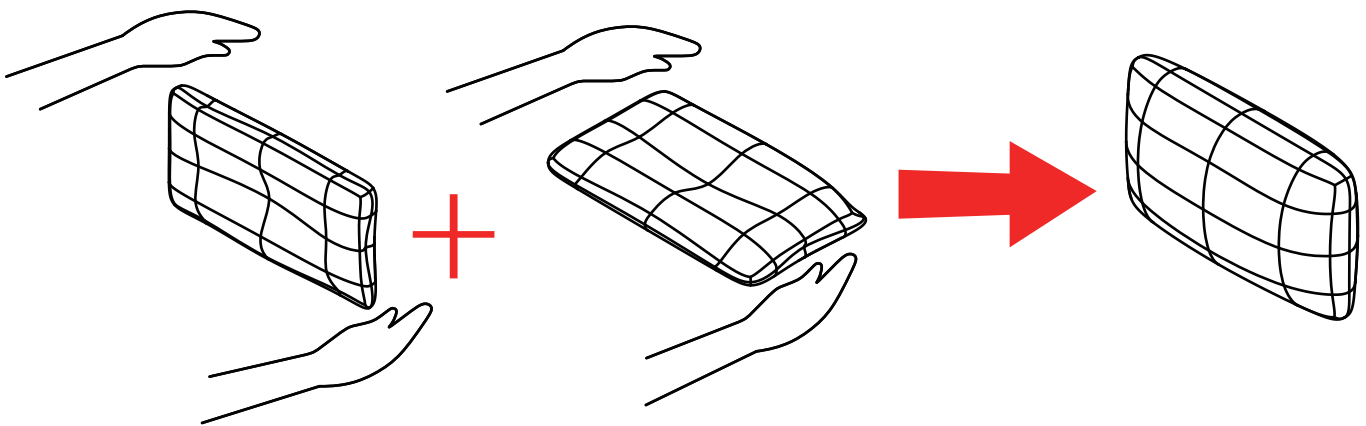

1. Repeatedly tap the sides and front and back to make it rebound better and fluffy.
2. Knead your cushion like giving your cushion a massage while allowing the air to flow through the foam.

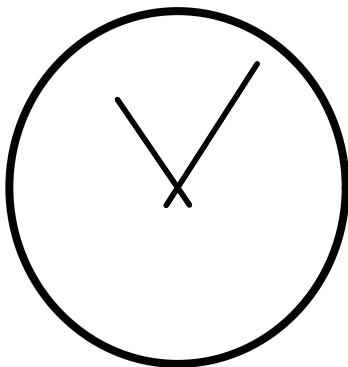

72h

It might takes up to 72 hours.