

ASSEMBLY INSTRUCTION (INSTRUCTIONS DE MONTAGE)

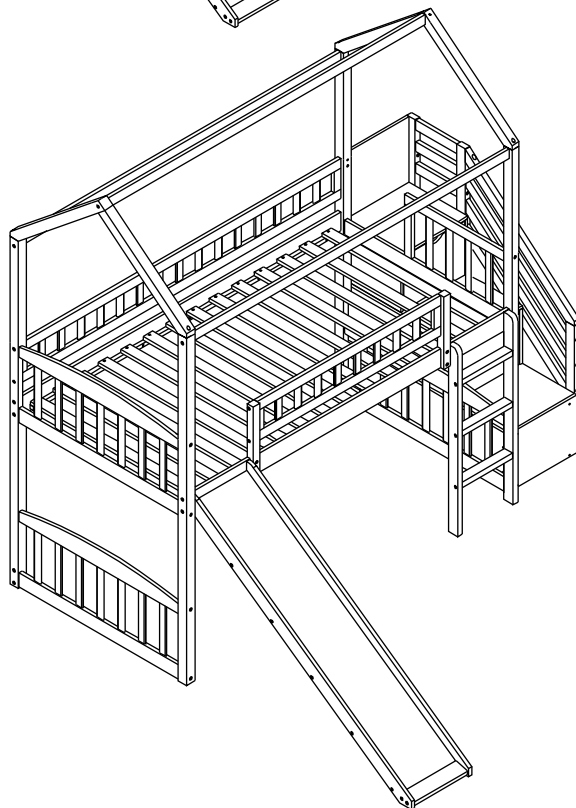

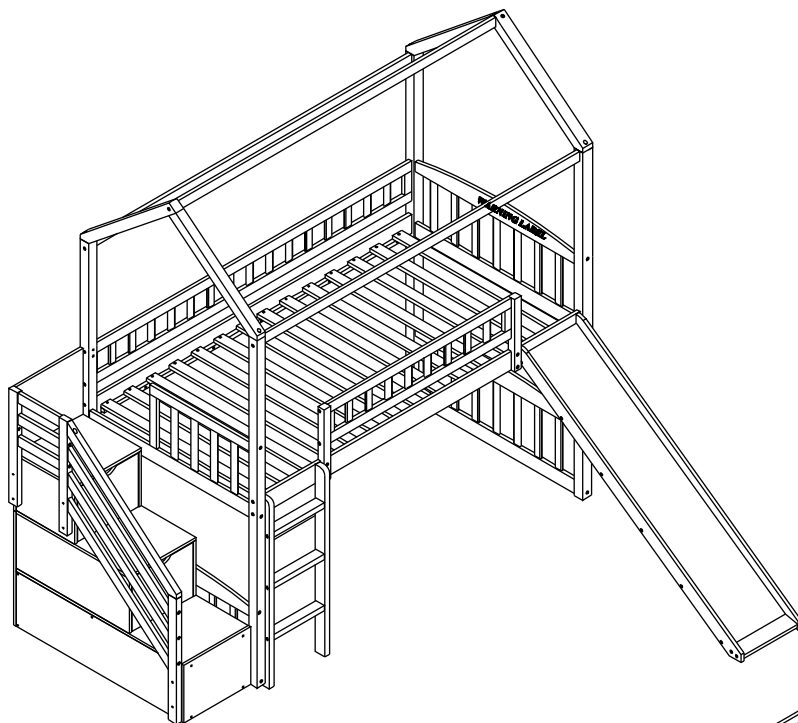

SAFETY WARNINGS

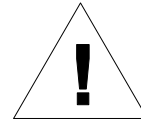

1. This bed is designed for use only mattress(es) meeting the following specifications on the upper bunk:

Upper bunk (bunk bed and tribed included)

| Bed Type | Length | Width | Thickness |
|----------------------|----------------|--------------------|------------------|
| <i>Twin Standard</i> | <i>74"-75"</i> | <i>37 ½"-38 ½"</i> | <i>6" max</i> |

2. Replacement parts, including additional guardrails, maybe obtained from any of our (GIGACLOUD TECHNOLOGY (USA) INC. 4388 SHIRLEY AVENUE EL MONTE, CA, 91731) dealers.
3. Follow the information on the warnings appearing on the upper bunk bed end structure and on the carton. Do not remove warning label from bed.
4. Always use the recommended size mattresses or mattress supports, or both, to help prevent the likelihood of entrapment or falls.
5. Surface of the mattress must be at least 5" (127 mm) below the upper edge of guardrails.
6. Do not allow children under 6 years of age to use the upper bunk.
7. Periodically check and ensure that the guardrail, ladder, and other components are in their proper position, free from damage, and that all connectors are tight.
8. Do not allow horseplay on or under the bed and prohibit jumping on the bed
9. Always use the ladder for entering and leaving the upper bunk.
10. Do not use substitute parts. Contact the manufacturer or dealer for replacement parts.
11. Use of a night light may provided added safety precaution for a child using the upper bunk.
12. Always use guardrails on both long sides of the upper bunk. If the bunk bed will be placed next to the wall, the guardrail that runs the full length of the bed should be placed against the wall to prevent entrapment between the bed and wall.
13. The use of water or sleep flotation mattresses is prohibited.
14. **STRANGULATION HAZARD** – Never attach or hang items to any part of the bunk bed that are not designed for use with the bed; for example, but not limited to, hook, belts and jump ropes.
15. Keep these instructions for future reference
16. Prohibit more than one person on upper bunk.
17. We recommend assembling your bunk bed on the shipping carton to protect your floor or carpet.
18. Be certain all staples are out of the box before beginning assembly on the shipping carton.



AVERTISSEMENTS DE SÉCURITÉ

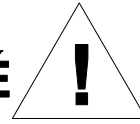

1. Ce lit est conçu pour utiliser uniquement des matelas répondant aux spécifications suivantes sur le lit supérieur et le lit inférieur.

Couchette supérieure (lits superposés et triblés inclus)

| Type de lit | Longueur | Largeur | Épaisseur |
|-----------------|----------|-------------------|-----------|
| Double Standard | 74"-75" | 37 1/2" - 38 1/2" | 6" max |

2. Des pièces de rechange, y compris des garde-corps supplémentaires, peuvent être obtenues auprès de l'un de nos revendeurs (GIGACLOUD TECHNOLOGY (USA) INC. 4388 SHIRLEY AVENUE EL MONTE, CA 91731) . 3. Suivez les informations sur les avertissements apparaissant sur le lit superposé supérieur et sur la structure ainsi que sur le carton. Ne retirez pas l'étiquette d'avertissement du lit.

4. Utilisez toujours des matelas ou des supports de matelas de taille recommandée, ou les deux, pour éviter

5. risque de coincement ou de chute.

La surface du matelas doit être à au moins 5" (127 mm) sous le bord supérieur des garde-corps.

6. Ne laissez pas les enfants de moins de 6 ans utiliser le lit supérieur.

7. Vérifiez et assurez-vous périodiquement que le garde-corps, l'échelle et les autres composants sont dans leur bonne position, exempts de dommages et que tous les connecteurs sont bien serrés.

8. Ne laissez pas les chahuts sur ou sous le lit et interdisez de sauter sur le lit.

9. Utilisez toujours l'échelle pour entrer et sortir du lit supérieur.

10. N'utilisez pas de pièces de rechange. Contactez le fabricant ou le revendeur pour les pièces de rechange.

11. L'utilisation d'une veilleuse peut constituer une mesure de sécurité supplémentaire pour un enfant utilisant le lit supérieur.

12. Utilisez toujours des garde-corps sur les deux côtés longs du lit supérieur. Si le lit superposé doit être placé à côté du mur, le garde-corps qui s'étend sur toute la longueur du lit doit être placé contre le mur pour éviter tout coincement entre le lit et le mur.

13. L'utilisation de matelas flottants à eau ou de sommeil est interdite.

14. RISQUE D'ÉTRANGULATION - N'attachez ou ne suspendez jamais d'objets à une partie du lit superposé qui ne sont pas conçus pour être utilisés avec le lit ; par exemple, mais sans s'y limiter, les crochets, les ceintures et

Cordes à sauter.

15. Conservez ces instructions pour référence future

16. Interdire plus d'une personne sur la couchette supérieure.

17. Nous vous recommandons d'assembler votre lit superposé sur le carton d'expédition pour protéger votre sol ou votre tapis.

18. Assurez-vous que toutes les agrafes sont sorties de la boîte avant de commencer l'assemblage sur le carton d'expédition.



SAFETY WARNINGS

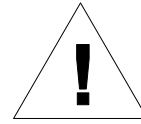

1. At the beginning :
 - Tighten all hardware.
 - Check metal parts for rust. If found, sand and repaint using a non-lead-based paint meeting the requirements of 16 CFR 1303.
 - Check all wood members for deterioration and splinters. Sand down splinters and replace deteriorating wood members.
 - Rake and check depth of loose fill protective surfacing materials to prevent compaction and to maintain appropriate depth. Replace as necessary.
2. Twice a month
 - Tighten all hardware.
 - Rake and check depth of loose fill protective surfacing materials to prevent compaction and to maintain appropriate depth. Replace as necessary.
3. Owners shall be responsible for maintaining the legibility of the warning labels.
4. Disposal Instructions-
 - There shall be instructions advising the owner to disassemble and dispose of the playground equipment in such a way that no unreasonable hazards will exist at the time the playground equipment is discarded.
5. The instructions shall also include the information found in Section 4 of the United States Consumer Product Safety Commission's (USCPSC) Outdoor Home Playground Safety Handbook or specific surfacing guidelines for the product consistent with the USCPSC Handbook. A copy of this section may be found in Appendix X2.
6. Observing the following statements and warnings reduces the likelihood of serious or fatal injury.
7. Specifying the number and weight of occupants that may safely use the equipment singly or simultaneously,
8. Recommending on-site adult supervision for children of all ages,
9. Warning the owner to instruct children not to use the equipment in a manner other than intended,
10. Warning the owner to instruct children not to get off equipment while it is in motion,
11. Warning the owner not to allow children to wear inappropriate items, such as but not limited to, loose fitting clothing, hood and neck drawstrings, scarves, cord-connected items, capes and ponchos. These items can cause death by strangulation.
12. Warning the owner to instruct children not to climb when the equipment is wet.
13. Warning the owner to instruct children not to attach items to the playground equipment that are not specifically designed for use with the equipment, such as, but not limited to, jump ropes, clothesline, pet leashes, cables and chain as they may cause a strangulation hazard
14. Warning the owner to instruct children to remove their bike or other sports helmet before playing on the playground equipment.
15. Warning the owner to dress children with well-fitting and full foot enclosing footwear. Examples of inappropriate footwear are clogs, flip flops, and sandals.
16. Place the equipment on level ground, not less than 6 ft (1.8 m) from any structure or obstruction such as a fence, garage, house, overhanging branches, laundry lines, or electrical wires
17. Do not install home playground equipment over concrete, asphalt, packed earth, grass, carpet, or any other hard surface. A fall onto a hard surface can result in serious injury or death to the equipment user
18. To prevent serious injury, cautionary statements shall be included which warn that children must not use the equipment until properly installed.



AVERTISSEMENTS DE SÉCURITÉ



1. Au début :

Serrez tout le matériel.

Vérifiez les pièces métalliques pour déceler la rouille. Si vous en trouvez, poncez et repeignez à l'aide d'une peinture sans plomb répondant aux exigences de 16 CFR 1303.

Vérifiez tous les éléments en bois pour déceler toute détérioration et éclats. Poncez les éclats et remplacer ceux qui se détériorent. membres en bois.

Ratissez et vérifiez la profondeur des matériaux de revêtement de protection en vrac pour éviter le compactage et maintenir profondeur appropriée. Remplacez si nécessaire.

2. Deux fois par mois

Serrez tout le matériel.

Ratissez et vérifiez la profondeur des matériaux de revêtement de protection en vrac pour éviter le compactage et maintenir profondeur appropriée. Remplacez si nécessaire.

3. Les propriétaires sont responsables du maintien de la lisibilité des étiquettes d'avertissement.

4. Instructions d'élimination-

Il doit y avoir des instructions conseillant au propriétaire de démonter et de se débarrasser de l'équipement de terrain de jeu. de telle manière qu'aucun danger déraisonnable n'existe au moment où l'équipement de terrain de jeu est mis au rebut.

5. Les instructions doivent également inclure les informations contenues dans la section 4 du document de consommation des États-Unis.

Manuel de sécurité des aires de jeux extérieures de la Commission de sécurité (USCPSC) ou revêtement spécifique directives pour le produit conformes au manuel USCPSC. Une copie de cette section peut être trouvée dans Annexe X2.

6. Le respect des déclarations et avertissements suivants réduit le risque de blessures graves, voire mortelles.

7. Préciser le nombre et le poids des occupants pouvant utiliser l'équipement en toute sécurité, seuls ou simultanément,

8. Recommander la surveillance d'un adulte sur place pour les enfants de tous âges,

9. Avertir le propriétaire de demander aux enfants de ne pas utiliser l'équipement d'une manière autre que celle prévue,

10. Avertir le propriétaire de demander aux enfants de ne pas descendre de l'équipement lorsqu'il est en mouvement,

11. Avertir le propriétaire de ne pas permettre aux enfants de porter des articles inappropriés, tels que, sans toutefois s'y limiter, des vêtements amples. vêtements, cordons de capuche et de cou, foulards, articles reliés par cordon, capes et ponchos. Ces articles peuvent provoquer la mort par strangulation.

12. Avertissez le propriétaire de demander aux enfants de ne pas grimper lorsque l'équipement est mouillé.

13. Avertir le propriétaire de demander aux enfants de ne pas attacher d'objets à l'équipement de terrain de jeu qui ne sont pas spécialement conçu pour être utilisé avec l'équipement, tel que, sans toutefois s'y limiter, des cordes à sauter, une corde à linge, un animal de compagnie laisses, câbles et chaînes car ils peuvent présenter un risque d'étranglement

14. Avertissez le propriétaire de demander aux enfants de retirer leur vélo ou autre casque de sport avant de jouer sur le équipement de terrain de jeu.

15. Avertir le propriétaire d'habiller les enfants avec des chaussures bien ajustées et couvrant tout le pied.

Exemples de les chaussures inappropriées sont les sabots, les tongs et les sandales.

16. Placez l'équipement sur un sol plat, à au moins 6 pi (1,8 m) de toute structure ou obstacle tel qu'un clôture, garage, maison, branches en surplomb, cordes à linge ou fils électriques

17. N'installez pas d'équipement de terrain de jeu domestique sur du béton, de l'asphalte, de la terre battue, de l'herbe, de la moquette ou tout autre surface dure. Une chute sur une surface dure peut entraîner des blessures graves, voire la mort de l'utilisateur de l'équipement.

18. Pour éviter des blessures graves, des mises en garde doivent être incluses pour avertir que les enfants ne doivent pas utiliser le l'équipement jusqu'à ce qu'il soit correctement installé.

Detail View - LOFT HOUSE BED
Vue détaillée - LIT MAISON LOFT

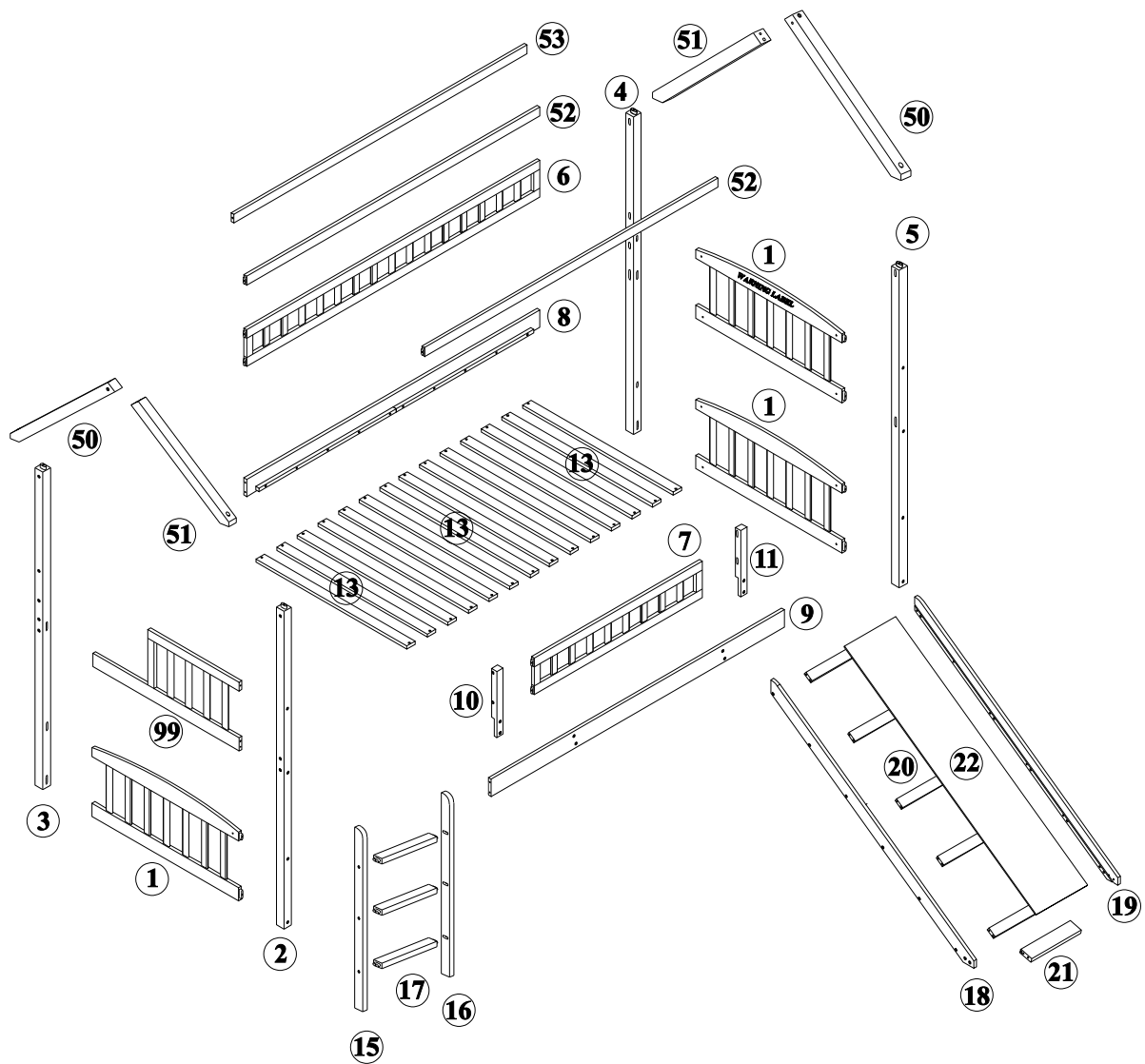



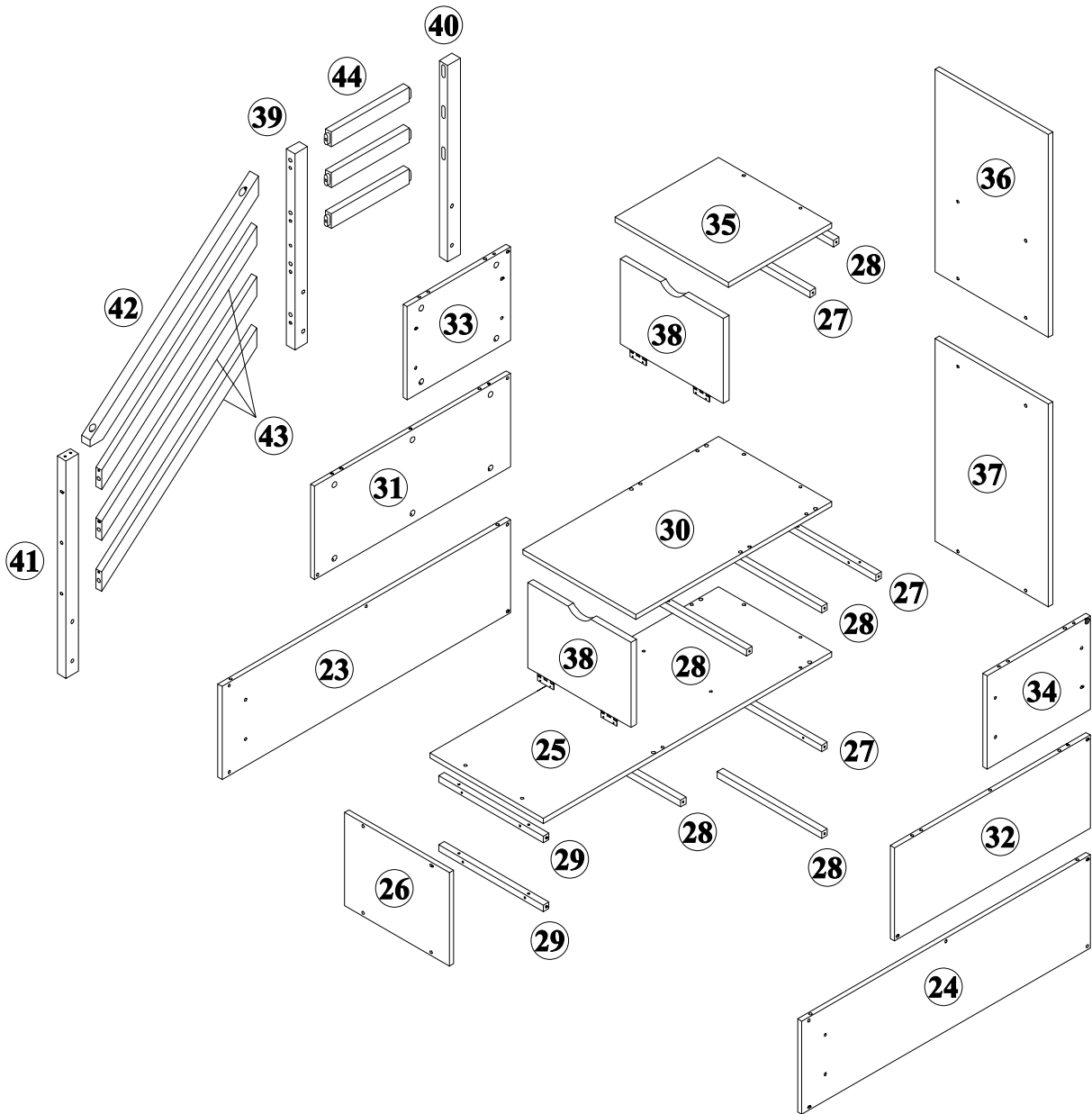

Identifying the Hardware - Identify the hardware using the illustrations below.
 (Identification du matériel - Identification du matériel à l'aide des illustrations ci-dessous)



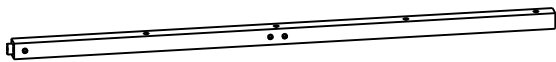

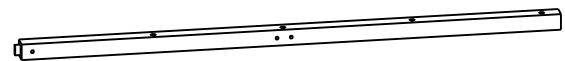
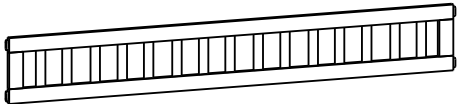
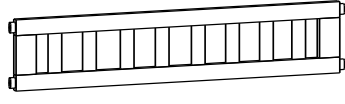
Detail View - STAIRS
Vue détaillée - Escaliers

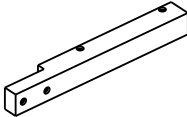
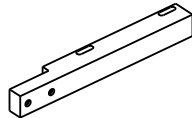
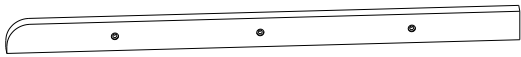
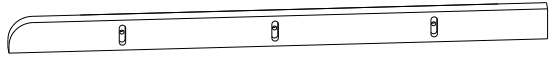

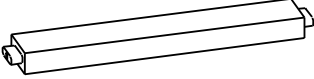
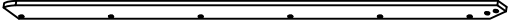

Part List (Liste des pièces) -

| | |
|---|---|
| <p>2</p>  <p>Left front bed column - 1pc (Colonne de lit avant gauche)</p> | <p>3</p>  <p>Left rear bed column - 1pc (Colonne de lit arrière gauche)</p> |
| <p>4</p>  <p>Right rear bed column - 1pc (Colonne de lit arrière droite)</p> | <p>5</p>  <p>Right front bed column - 1pc (Colonne de lit avant droite)</p> |
| <p>6</p>  <p>Back guard rail frame - 1pc (Cadre de garde-corps arrière)</p> | <p>7</p>  <p>Front guard rail frame - 1pc (Cadre de garde-corps avant)</p> |
| <p>8</p>  <p>Bed side plate (A) - 1pc (Plaque de côté de lit)</p> | <p>9</p>  <p>Bed side plate (B) - 1pc (Plaque de côté de lit)</p> |
| <p>10</p>  <p>Left front guard rails support - 1pc (Support de garde-corps avant gauche)</p> | <p>11</p>  <p>Right front guard rails support - 1pc (Support de garde-corps avant droit)</p> |
| <p>15</p>  <p>Bed ladder column (A) - 1pc (Colonne échelle de lit)</p> | <p>16</p>  <p>Bed ladder column (B) - 1pc (Colonne échelle de lit)</p> |

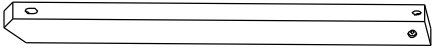
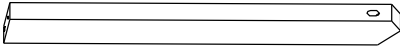
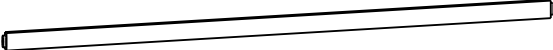
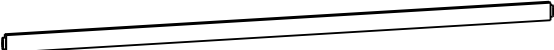
Part List (Liste des pièces) -

| | |
|---|--|
| <p>17</p>  <p>Step of bed ladder - 3pcs (Marche d'échelle)</p> | <p>18</p>  <p>Slide column (A) - 1pc (Colonne de diapositives)</p> |
| <p>19</p>  <p>Slide column (B) - 1pc (Colonne de diapositives)</p> | <p>20</p>  <p>Slide support wood - 5pcs (Prise en charge des diapositives)</p> |
| <p>21</p>  <p>Slide bottom panel - 1pc (Panneau inférieur coulissant)</p> | <p>22</p>  <p>Slide panel - 1pc (Panneau de diapositives)</p> |
| <p>50</p>  <p>Roof connecting bar (A) - 2pcs (Barre de raccordement de toit)</p> | <p>51</p>  <p>Roof connecting bar (B) - 2pcs (Barre de raccordement de toit)</p> |
| <p>52</p>  <p>Roof connecting bar (C) - 2pcs (Barre de raccordement de toit)</p> | <p>53</p>  <p>Roof connecting bar (C) - 1pc (Barre de raccordement de toit)</p> |

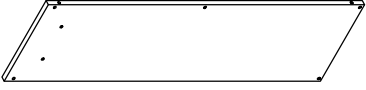
Part List (Liste des pièces) -

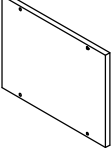
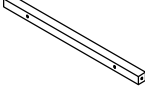
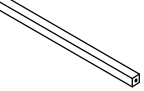
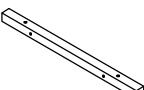
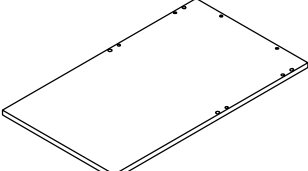
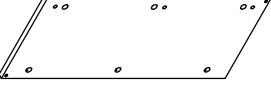
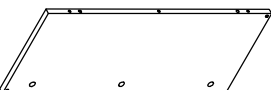
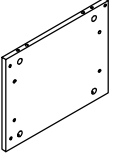
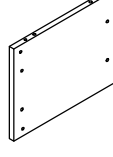
| | |
|--|---|
| <p>23</p>  <p>Left Side panel- 1pc (Panneau latéral gauche)</p> | <p>24</p>  <p>Right Side panel- 1pc (Panneau latéral droit)</p> |
| <p>25</p>  <p>Storage ladder bottom panel- 1pc (Panneau inférieur d'échelle de rangement)</p> | <p>26</p>  <p>Storage ladder front panel- 1 pc (Panneau avant d'échelle de rangement)</p> |
| <p>27</p>  <p>Storage ladder support (A) - 3pcs (Support d'échelle de rangement)</p> | <p>28</p>  <p>Storage ladder support (B) - 5pcs (Support d'échelle de rangement)</p> |
| <p>29</p>  <p>Storage ladder support (C) - 2pcs (Support d'échelle de rangement)</p> | <p>30</p>  <p>Storage ladder between panel - 1pc (Échelle de rangement entre panneau)</p> |
| <p>31</p>  <p>Left Side panel (A) - 1pc (Panneau latéral gauche)</p> | <p>32</p>  <p>Right Side panel (A) - 1pc (Panneau latéral droit)</p> |
| <p>33</p>  <p>Left Side panel (B) - 1pc (Panneau latéral gauche)</p> | <p>34</p>  <p>Right Side panel (B) - 1pc (Panneau latéral droit)</p> |



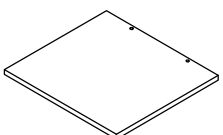
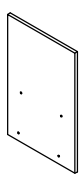
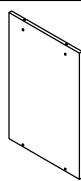
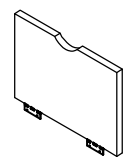
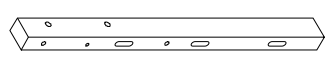
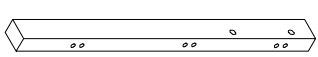
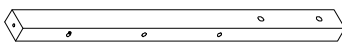
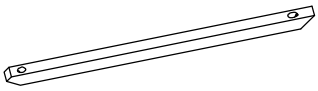
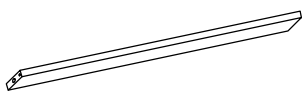
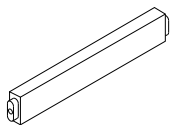



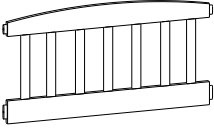
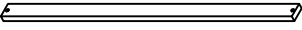
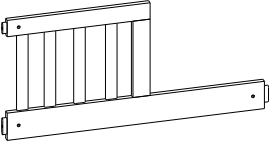



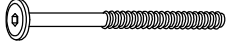

Part List (Liste des pièces) -

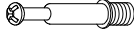
| | |
|---|---|
| <p>35</p>  <p>Storage ladder top panel- 1pc (Panneau supérieur d'échelle de rangement)</p> | <p>36</p>  <p>Storage ladder top back panel - 1pc (Panneau arrière supérieur d'échelle de rangement)</p> |
| <p>37</p>  <p>Storage ladder bottom back panel - 1pc (Panneau arrière inférieur de l'échelle de rangement)</p> | <p>38</p>  <p>Storage ladder door panels- 2pcs (Panneaux de porte d'échelle de rangement)</p> |
| <p>39</p>  <p>Storage ladder support (A) - 1pc (Support d'échelle de rangement)</p> | <p>40</p>  <p>Storage ladder support (B) - 1pc (Support d'échelle de rangement)</p> |
| <p>41</p>  <p>Storage ladder support (C) - 1pc (Support d'échelle de rangement)</p> | <p>42</p>  <p>Storage ladder support (D) - 1pc (Support d'échelle de rangement)</p> |
| <p>43</p>  <p>Storage ladder supports (E) - 3pcs (Support d'échelle de rangement)</p> | <p>44</p>  <p>Storage ladder supports (F) - 3pcs (Support d'échelle de rangement)</p> |

Part List (Liste des pièces) -

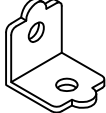
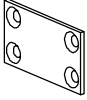
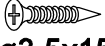
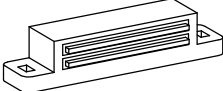
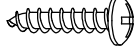
| | |
|--|--|
| <p>1</p>  <p>Headboard (A) - 3pcs (Tête de lit)</p> | <p>13</p>  <p>Bed board - 14pcs (Planche de lit)</p> |
| <p>99</p>  <p>Headboard (B) - 1pc (Tête de lit)</p> | |

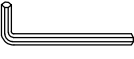

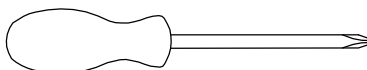

Hardware List (Liste du matériel) -

| | | |
|--|--|---|
| <p>A</p>  <p>ø13x1/4"x80mm</p> | <p>B</p>  <p>ø13x1/4"x30mm</p> | <p>C</p>  <p>ø13x1/4"x30mm</p> |
| <p>Hex-Head bolts - 31pcs (Boulon à tête hexagonale)</p> | <p>Hex-Head bolts - 4pcs (Boulon à tête hexagonale)</p> | <p>Hex-Head screw - 18pcs (Vis à tête hexagonale)</p> |
| <p>E</p>  <p>ø13*1/4"*60mm</p> | <p>F</p>  <p>ø10x13mm</p> | <p>G</p>  <p>ø6x35mm</p> |
| <p>Hex-Head screw - 12pcs (Vis à tête hexagonale)</p> | <p>Horizontal-Hole bolts - 77pcs (Boulons à trou horizontal)</p> | <p>Three in one bolts - 20 pcs (Boulons trois en un)</p> |
| <p>H</p>  <p>ø14.5x12mm</p> | <p>Y</p>  <p>ø8xø4x30mm</p> | <p>K</p>  <p>ø7xø3.5x18mm</p> |
| <p>Three in one lock - 20pcs (Serrure trois en un)</p> | <p>Round head screw - 38pcs (Vis à tête ronde)</p> | <p>Flat head screw - 12pcs (Vis à tête plate)</p> |
| <p>L</p>  <p>20x20x19mm</p> | <p>M</p>  <p>50x31x2mm</p> | <p>N</p>  <p>ø7xø3.5x15mm</p> |
| <p>L-Bracket - 2pcs (Support en L)</p> | <p>Connecting iron sheet - 3pcs (Tôle de fer de connexion)</p> | <p>Flat head screw - 16pcs (Vis à tête plate)</p> |
| <p>O</p>  <p>45x16x14mm</p> | <p>P</p>  <p>ø6xø3x12mm</p> | <p>Q</p>  <p>35x12x1mm</p> |
| <p>Door magnet - 4 pcs (Aimant de porte)</p> | <p>Round head screw - 8pcs (Vis à tête ronde)</p> | <p>Magnetic iron sheet - 4pcs (Feuille de fer magnétique)</p> |
| <p>R</p>  <p>ø6xø3x12mm</p> | <p>S</p>  <p>4mm</p> | <p>T</p>  <p>ø10x40mm</p> |
| <p>Flat head screw - 16pcs (Vis à tête plate)</p> | <p>Allen key - 1pc (Clef Allen)</p> | <p>Wood dowel - 26pcs (Cheville en bois)</p> |

ASSEMBLY TOOLS REQUIRED (NOT INCLUDED)

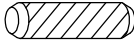
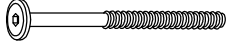

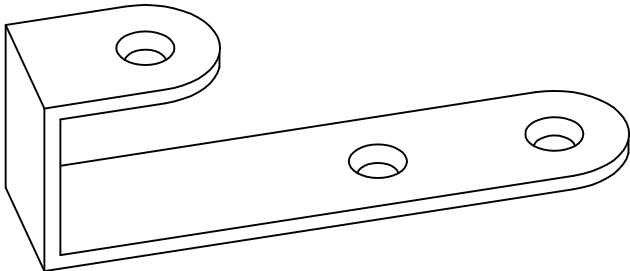

Hardware List (Liste du matériel) -

| | | |
|--|---|---|
| <p>U</p>  <p>ø8x30mm</p> | <p>V</p>  <p>ø13x1/4"x 60mm</p> | <p>W</p>  <p>ø13*1/4"x100mm</p> |
| <p>Wood dowel - 28pcs (Cheville en bois)</p> | <p>Hex-Head bolts -46pcs (Boulon à tête hexagonale)</p> | <p>Hex-Head screw -1pc (Vis à tête hexagonale)</p> |
| <p>D</p>  <p>ø13xø6.2x50mm</p> | | <p>Z</p>  <p>ø13*1/4"x70mm</p> |
| <p>Hex-Head screw - 5pcs (Vis à tête hexagonale)</p> | | <p>Hex-Head screw -4pcs (Vis à tête hexagonale)</p> |
| <p>J</p>  <p>ø75x18x24mm</p> | | |
| <p>Stair hook - 4pcs (Crochet d'escalier)</p> | | |

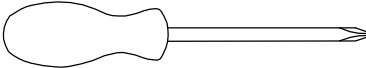
ASSEMBLY TOOLS REQUIRED (NOT INCLUDED)



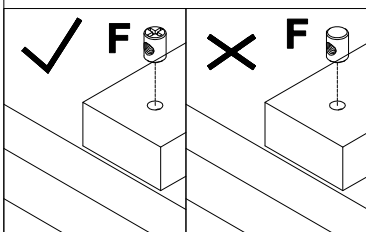
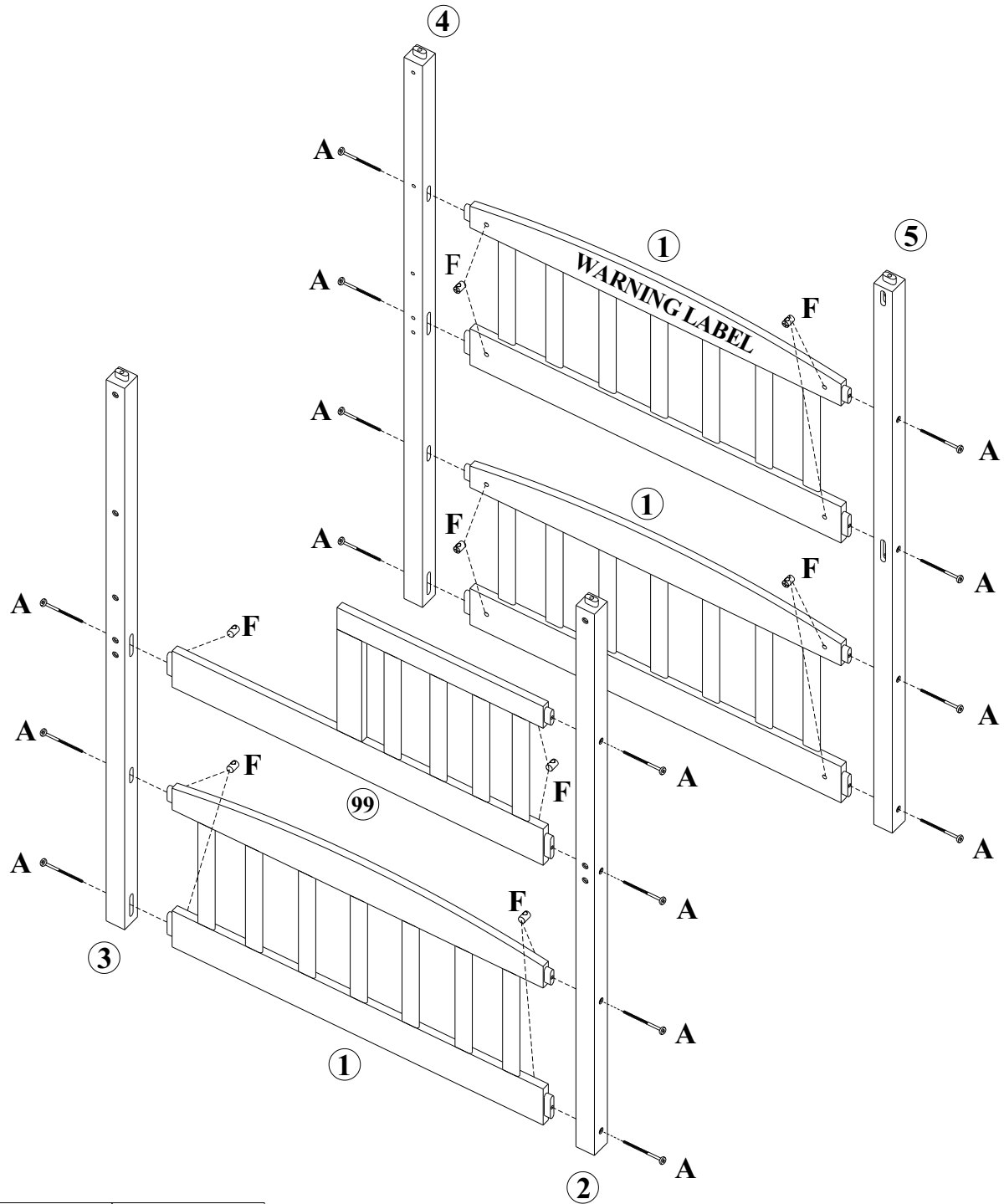

STEP: 1
(ÉTAPE: 1)

| | |
|---|---|
| A | F |
|  |  |
| 15PCS | 15PCS |



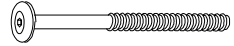

STEP: 2
(ÉTAPE: 2)

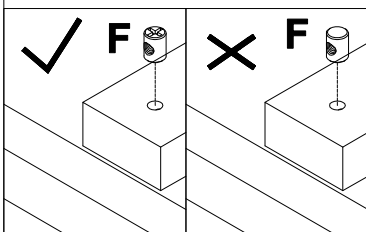
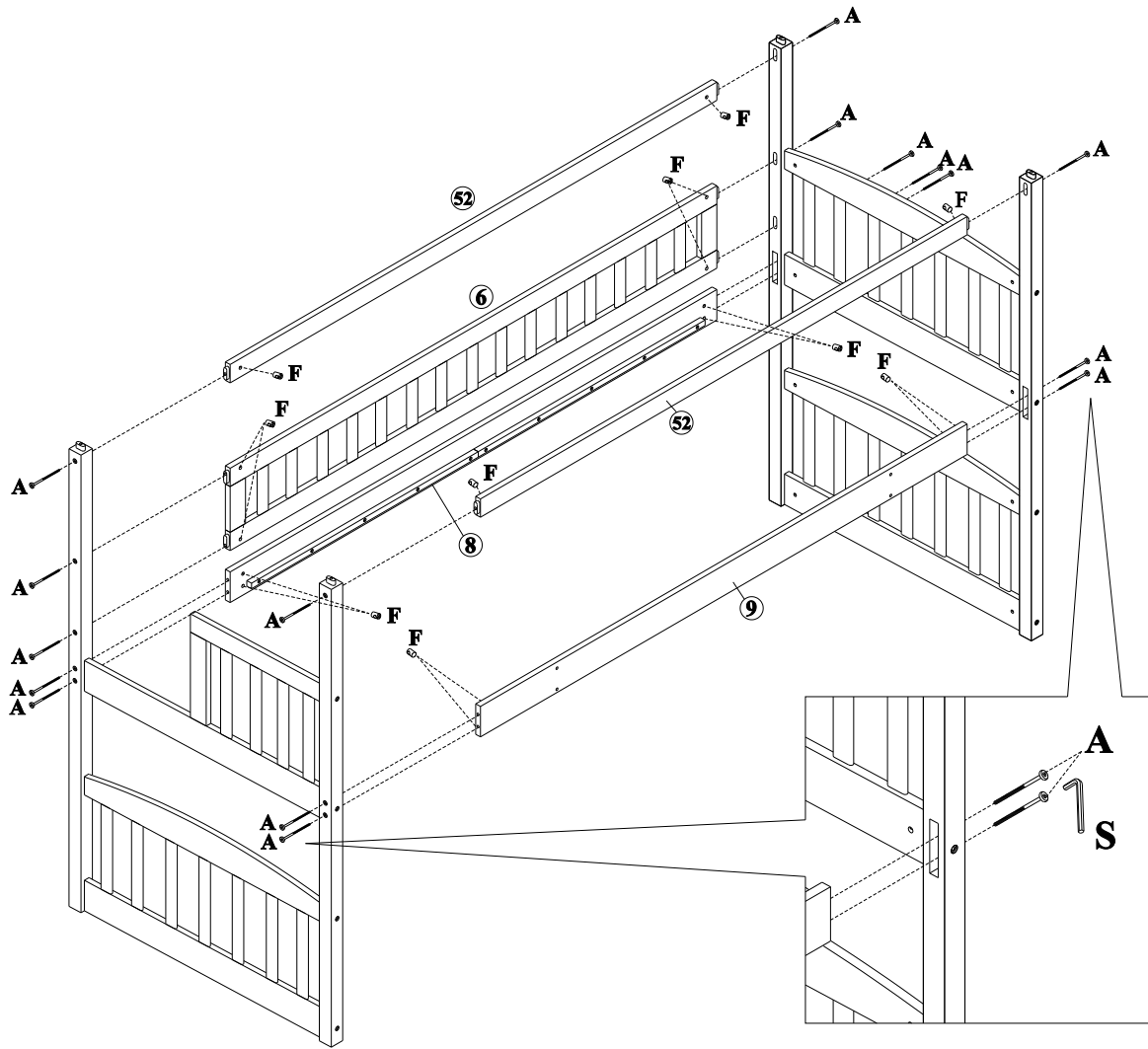
| | | | |
|--------------|---|--------------|---|
| A |  | F |  |
| 16PCS | | 16PCS | |



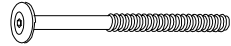

STEP: 3
(ÉTAPE: 3)

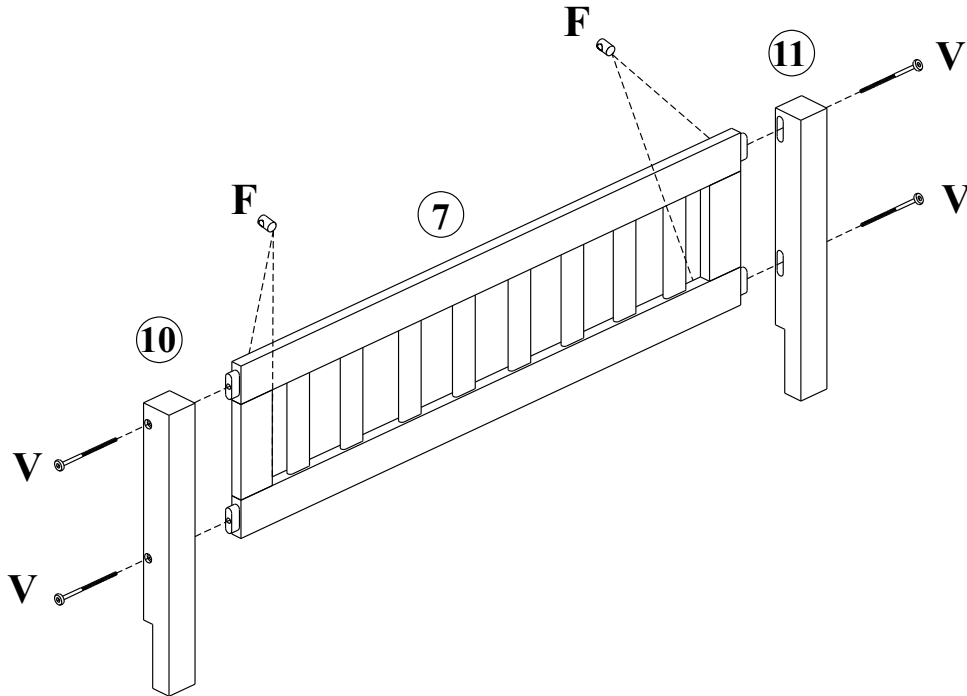
| | | | |
|----------|---|----------|---|
| V |  | F |  |
| | 4PCS | | 4PCS |



STEP: 4
(ÉTAPE: 4)

| | | | |
|----------|---|----------|---|
| B |  | Y |  |
| | 4PCS | | 28PCS |

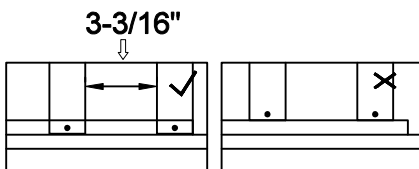

Note: Do not lock the screws of the bed slats to the outermost edge of the bed slats, you need to leave a certain space at the edges, otherwise it will cause the board to break.
(Remarque : Ne verrouillez pas les vis des lattes du lit sur le bord le plus extérieur des lattes du lit, vous devez laisser un certain espace sur les bords, sinon la planche risque de se casser)

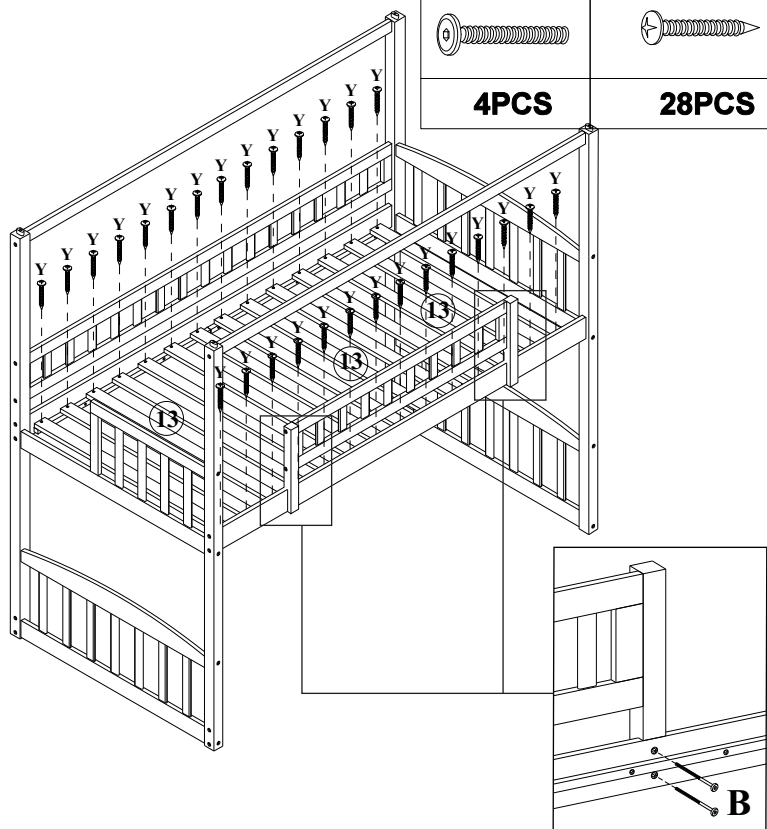

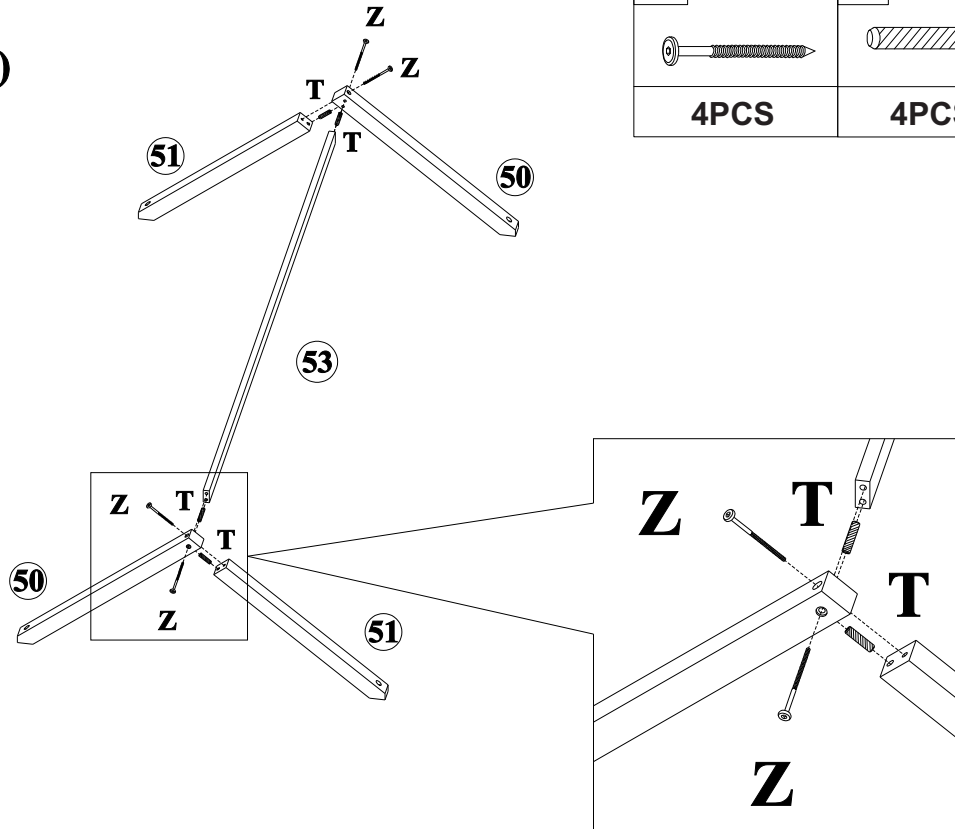

STEP: 5
(ÉTAPE: 5)

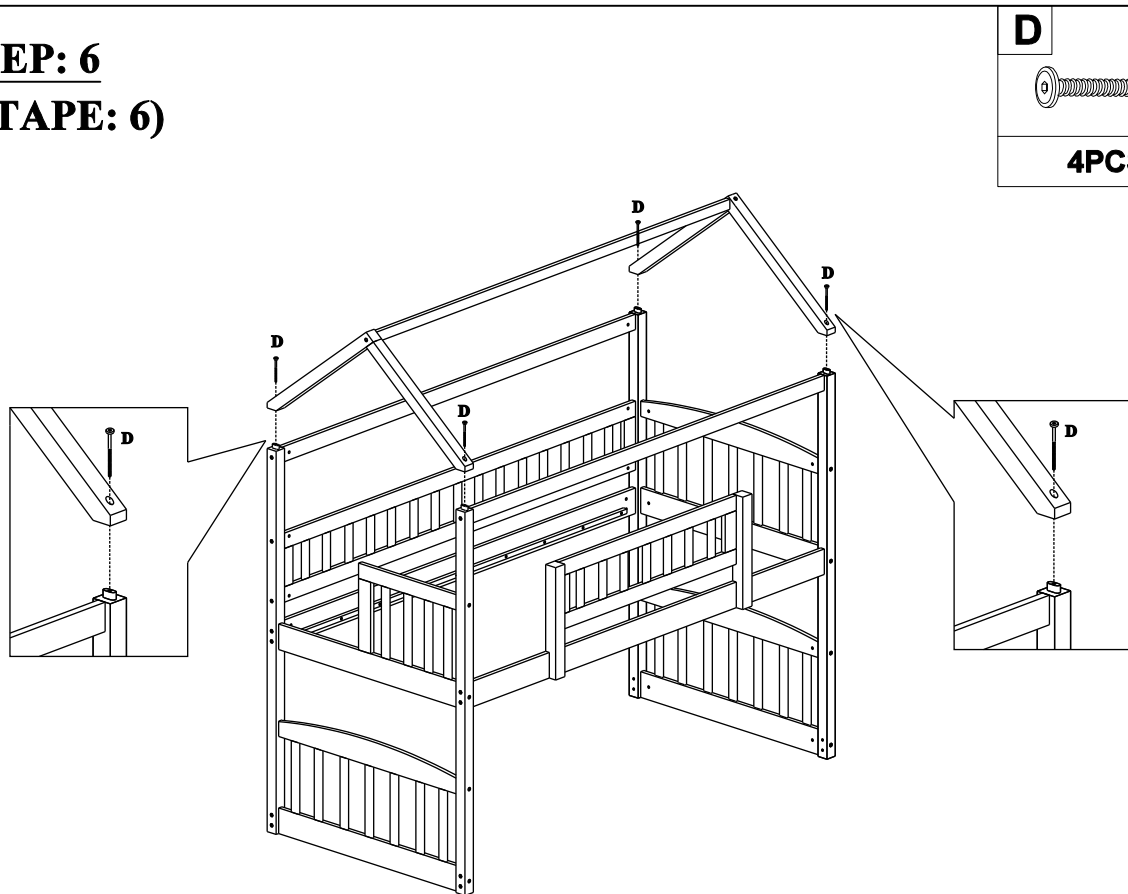

STEP: 6
(ÉTAPE: 6)



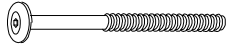

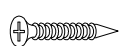
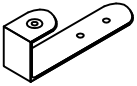

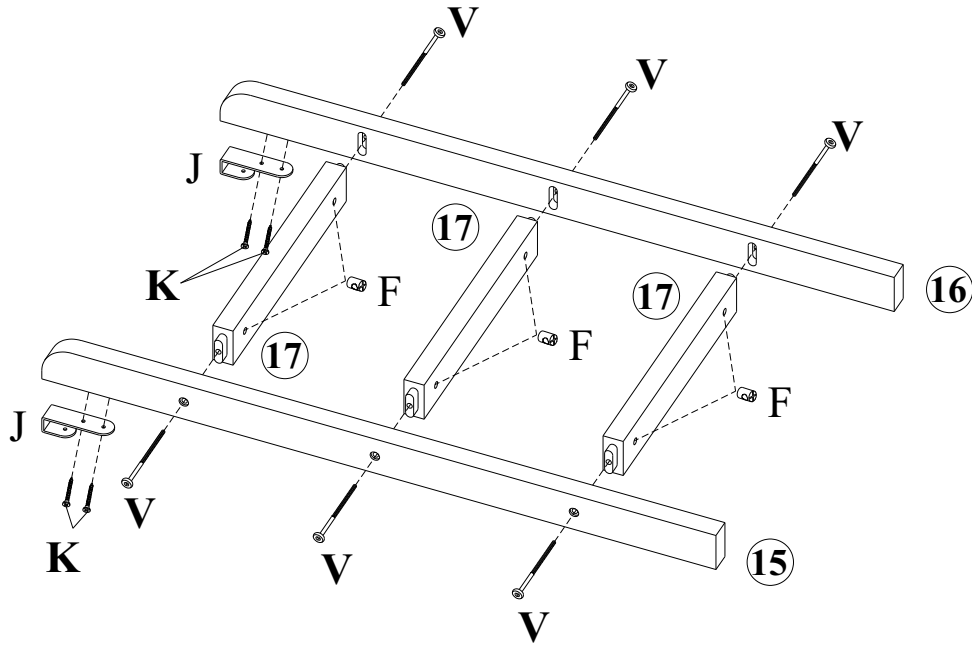
STEP: 7
(ÉTAPE: 7)

| | | | |
|---|---|---|---|
| V  | F  | K  | J  |
| 6PCS | 6PCS | 4PCS | 2PCS |

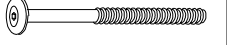

STEP: 8
(ÉTAPE: 8)

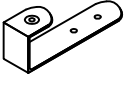
| | | | | |
|---|---|--|---|---|
| V  | F  | T  | K  | J  |
| 14PCS | 14PCS | 22PCS | 4PCS | 2PCS |

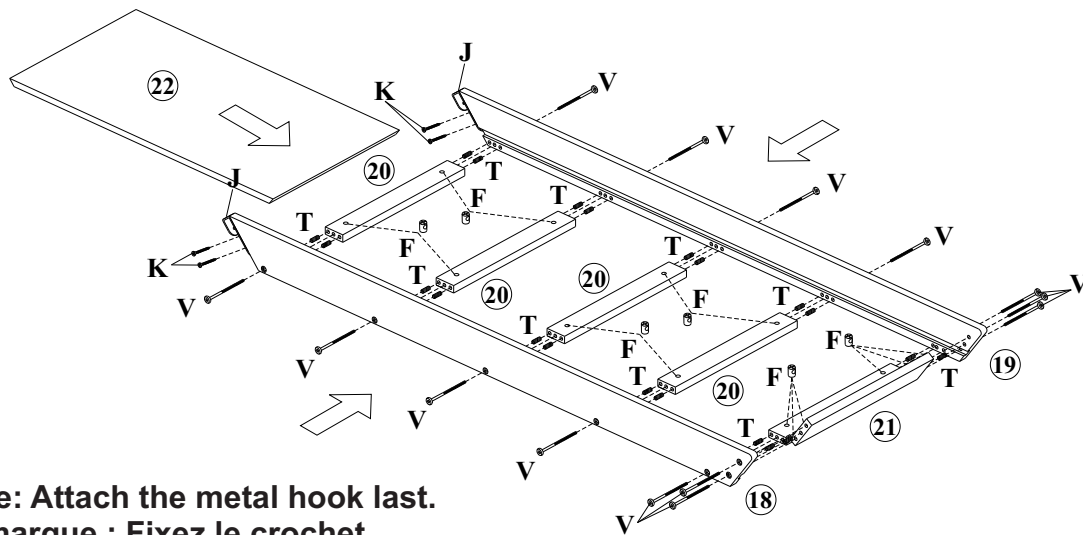

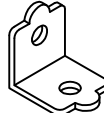
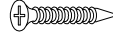

Note: Attach the metal hook last.
Remarque : Fixez le crochet métallique en dernier.

STEP: 9
(ÉTAPE: 9)

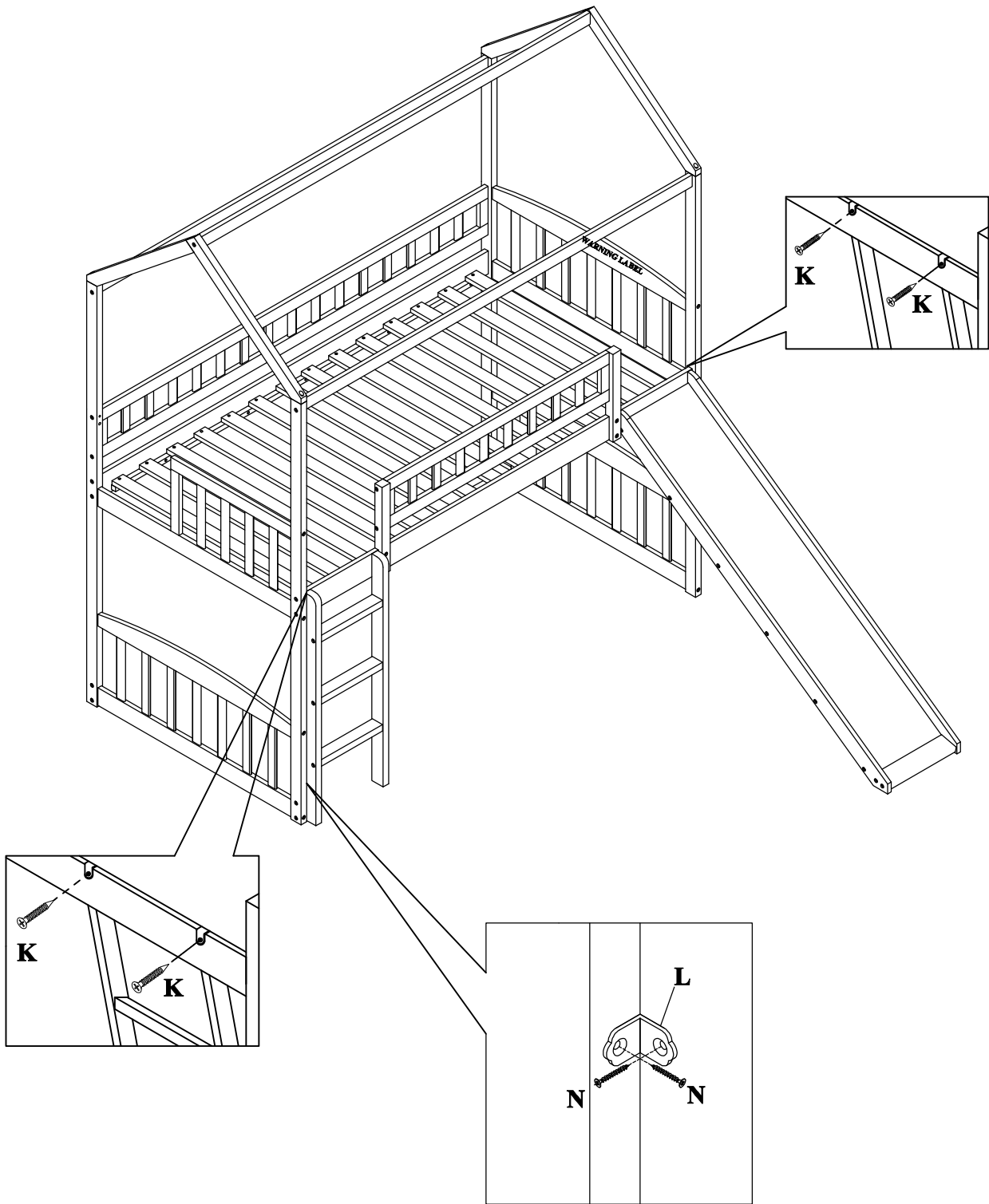
| | | |
|---|---|---|
| N | L | K |
|  |  |  |
| 2 PCS | 1 PC | 4PCS |



STEP: 10
(ÉTAPE: 10)

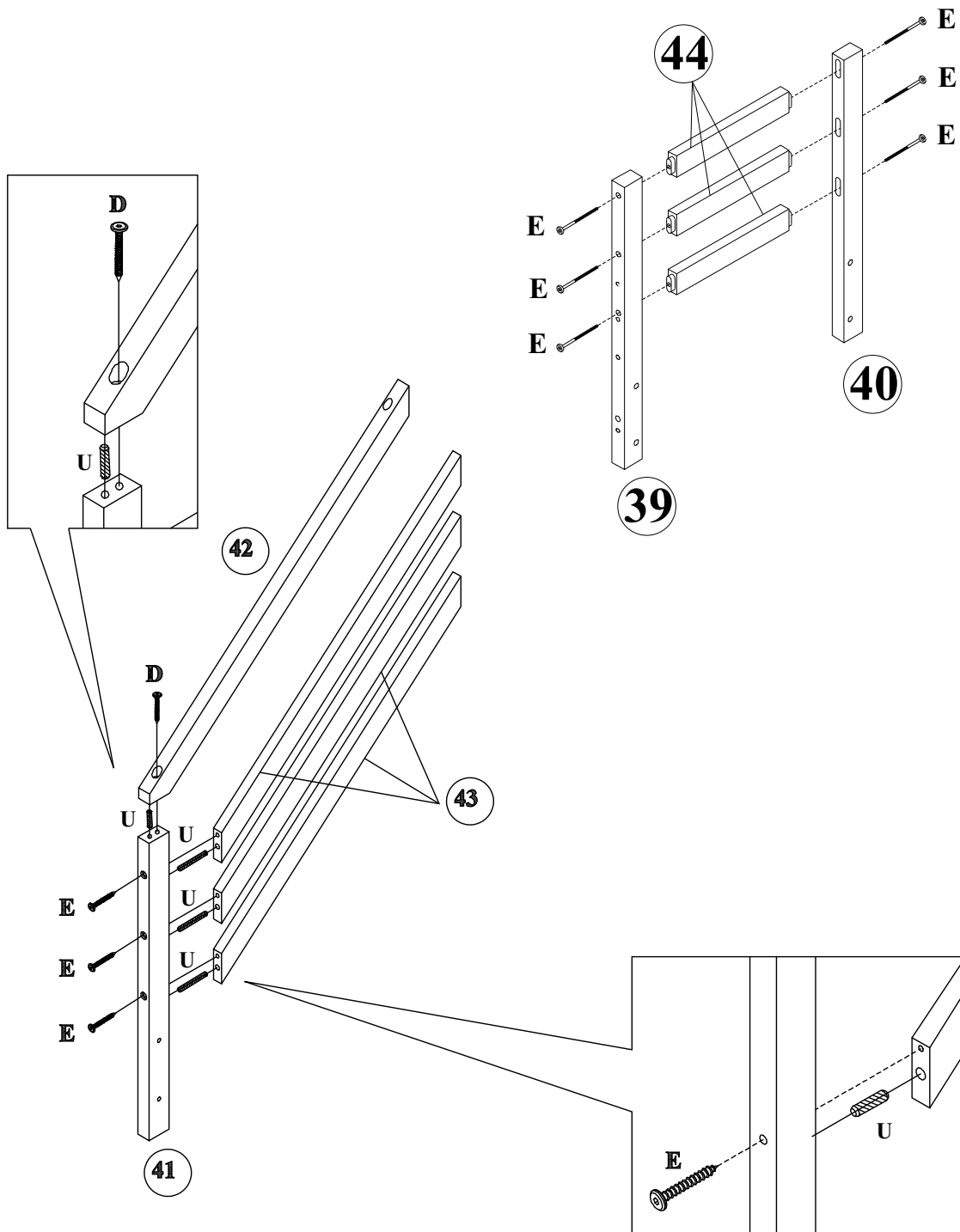

| D | U | E |
|---|---|---|
|  |  |  |
| 1 PCS | 4 PCS | 9 PCS |

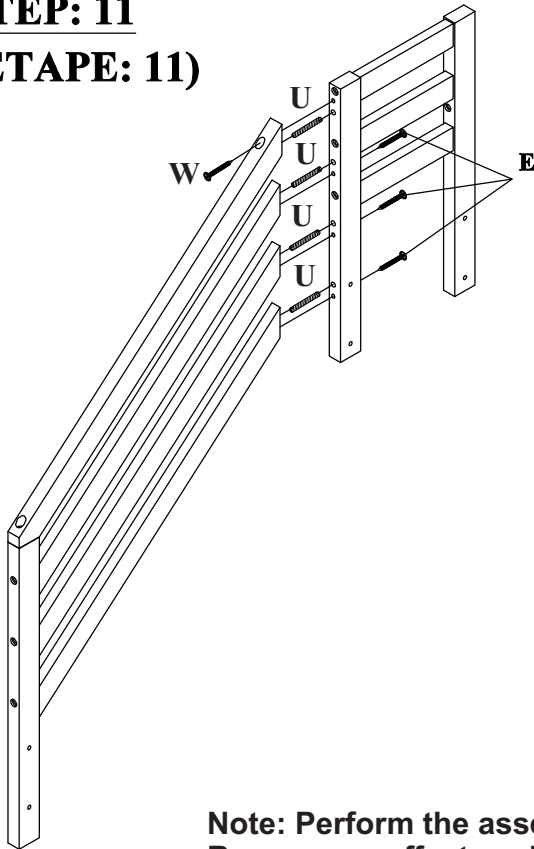

Note: Perform the assembly steps but do not tighten.
Remarque : effectuez les étapes d'assemblage mais ne serrez pas

STEP: 11
(ÉTAPE: 11)

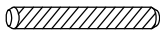

| U | W | E |
|---|---|---|
|  |  |  |
| 4 PCS | 1 PC | 3 PCS |

Note: Perform the assembly steps but do not tighten.
Remarque : effectuez les étapes d'assemblage mais ne serrez pas

STEP: 12
(ÉTAPE: 12)

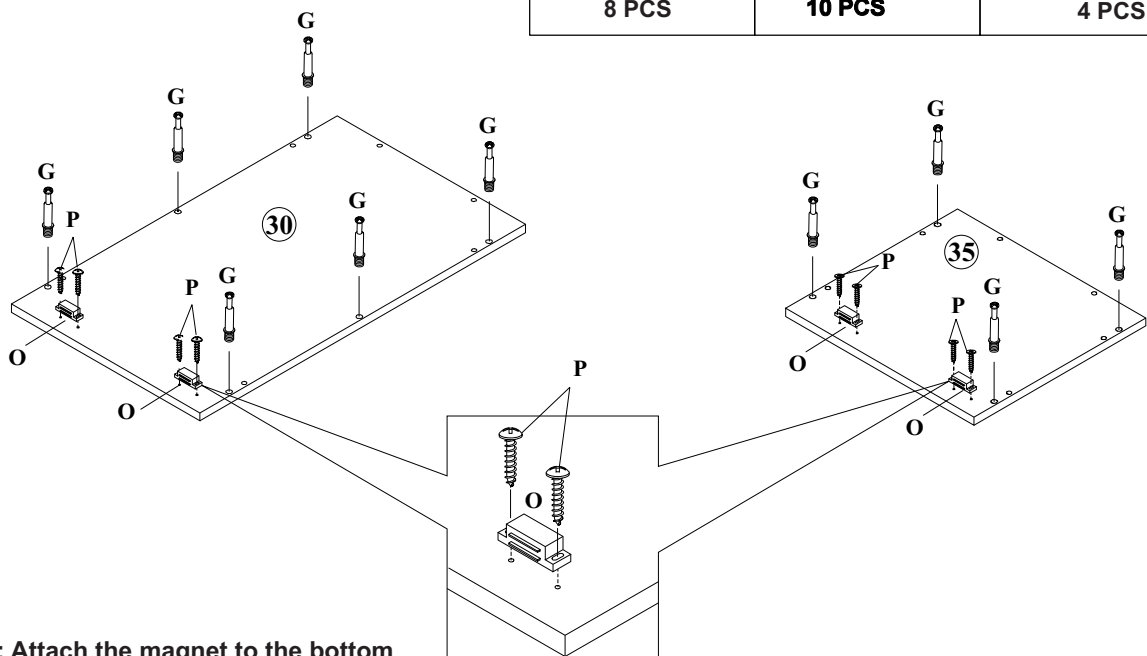

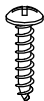
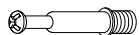
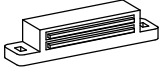

| P | G | O |
|---|---|---|
|  |  |  |
| 8 PCS | 10 PCS | 4 PCS |

Note: Attach the magnet to the bottom surface with the number label attached.
Remarque : Fixez l'aimant sur la face inférieure avec l'étiquette numérotée collée.

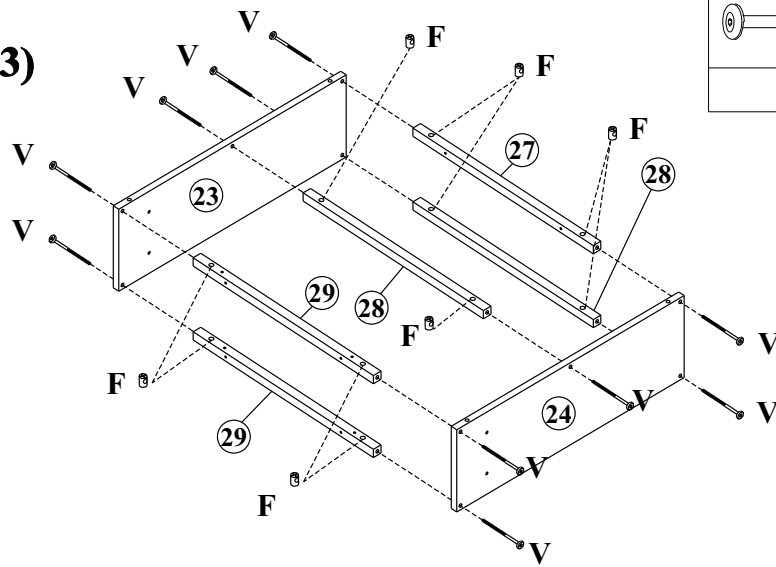
STEP: 13
(ÉTAPE: 13)

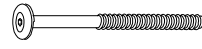

| | | | |
|----------|---|----------|---|
| V |  | F |  |
| | 10PCS | | 10PCS |

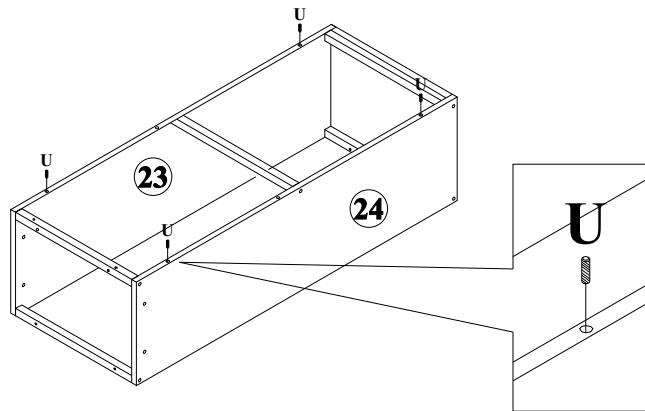

STEP: 14
(ÉTAPE: 14)

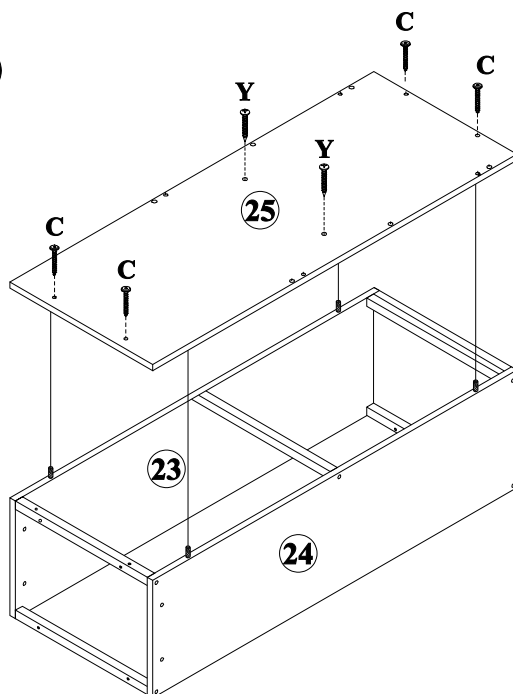

| | |
|----------|---|
| U |  |
| | 4PCS |

STEP: 15
(ÉTAPE: 15)



| | | | |
|----------|---|----------|---|
| C |  | Y |  |
| | 4PCS | | 2PCS |

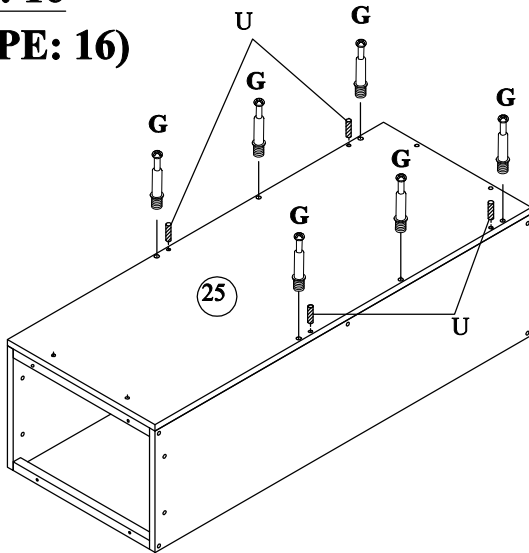

STEP: 16
(ÉTAPE: 16)

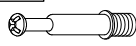
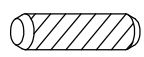

| | | | |
|--------------|---|--------------|---|
| G |  | U |  |
| 6 PCS | | 4 PCS | |

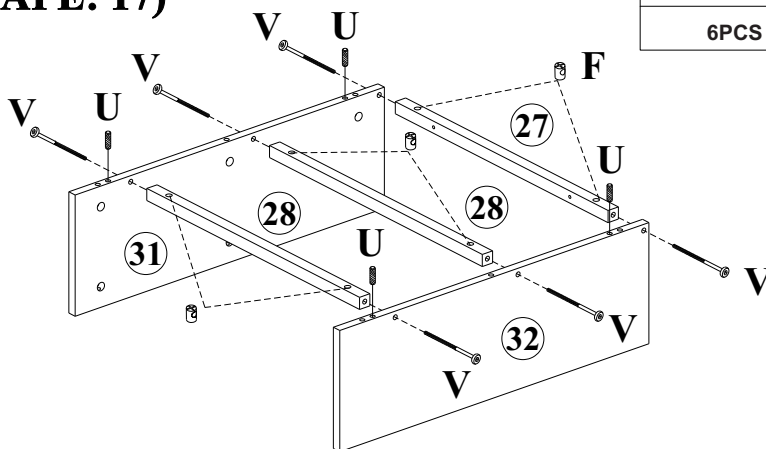
STEP: 17
(ÉTAPE: 17)

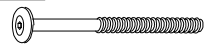

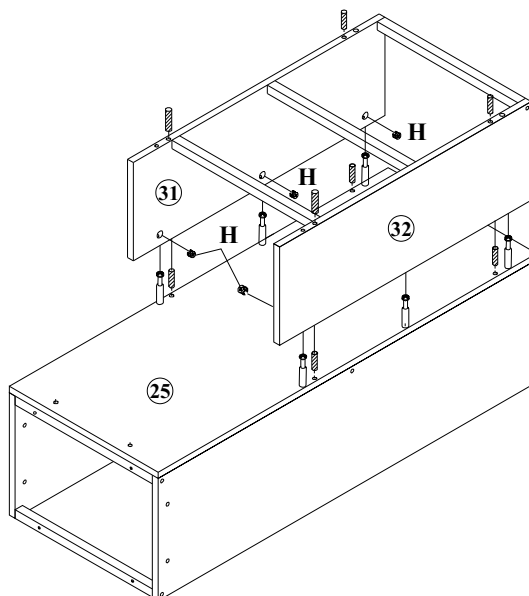

| | | | | | |
|--------------|--|--------------|---|--------------|---|
| V |  | F |  | U |  |
| 6 PCS | | 6 PCS | | 4 PCS | |

STEP: 18
(ÉTAPE: 18)



| | |
|--------------|---|
| H |  |
| 6 PCS | |

STEP: 19
(ÉTAPE: 19)

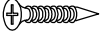
| | | | |
|---|---|---|---|
| C | H | Q | R |
|  |  |  |  |
| 2 PCS | 6 PCS | 2 PCS | 8 PCS |

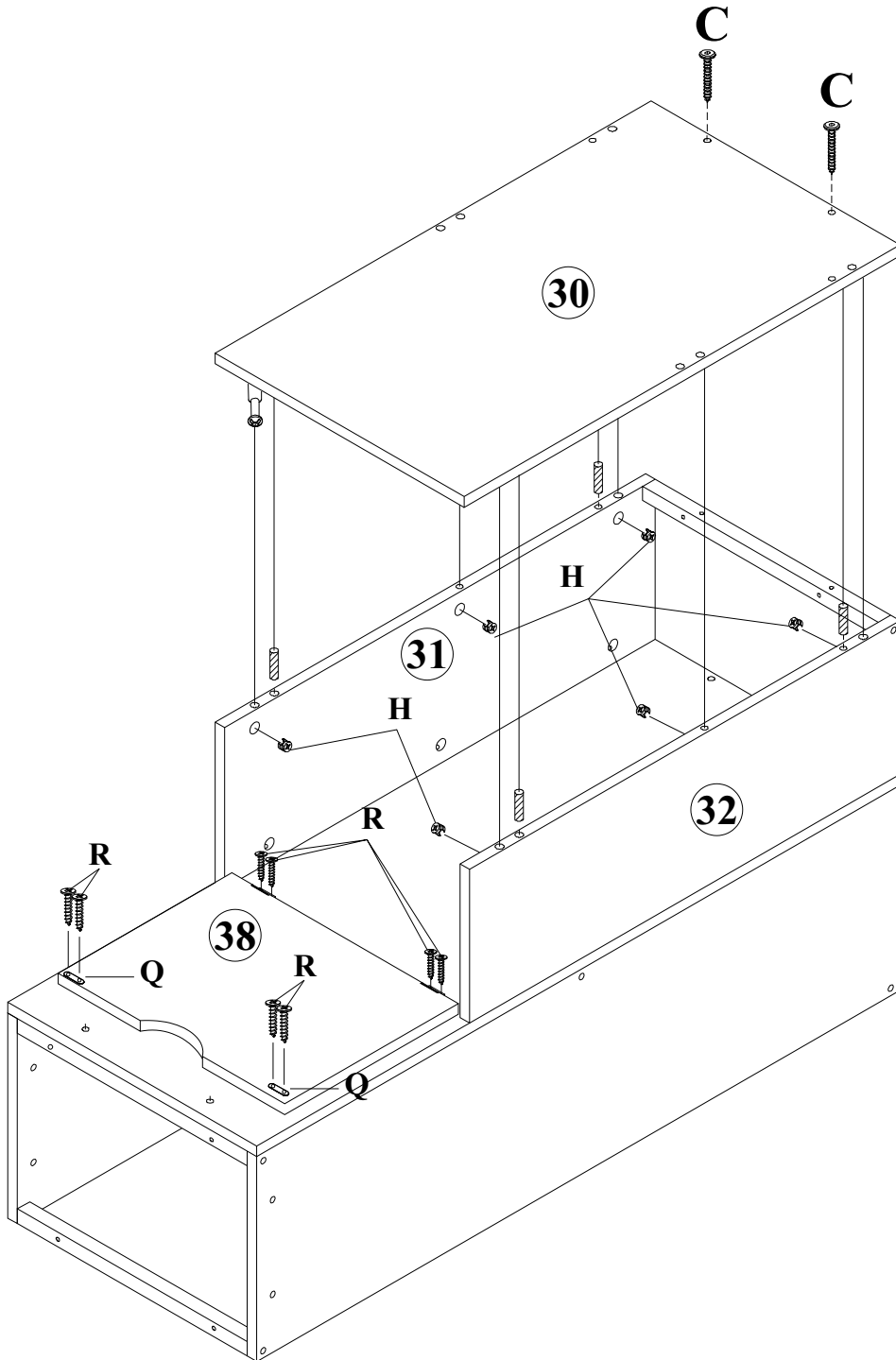

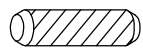
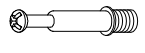

STEP: 20
(ÉTAPE: 20)

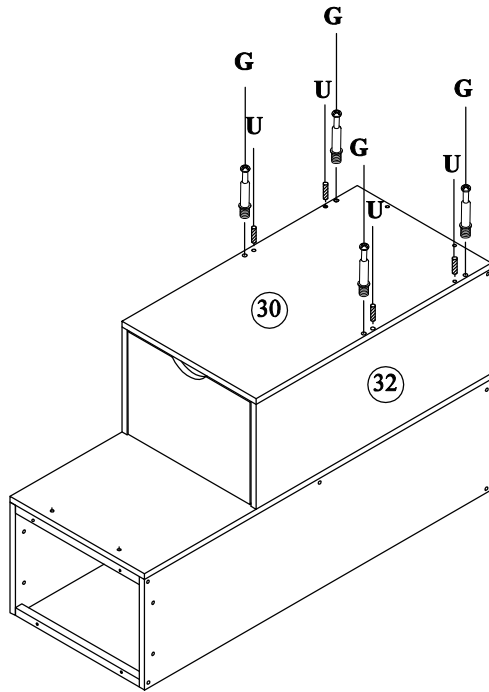
| | | | |
|--------------|---|--------------|---|
| U |  | G |  |
| 4 PCS | | 4 PCS | |

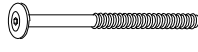

STEP: 21
(ÉTAPE: 21)

| | | | | | |
|-------------|--|-------------|---|-------------|---|
| V |  | F |  | U |  |
| 4PCS | | 4PCS | | 4PCS | |

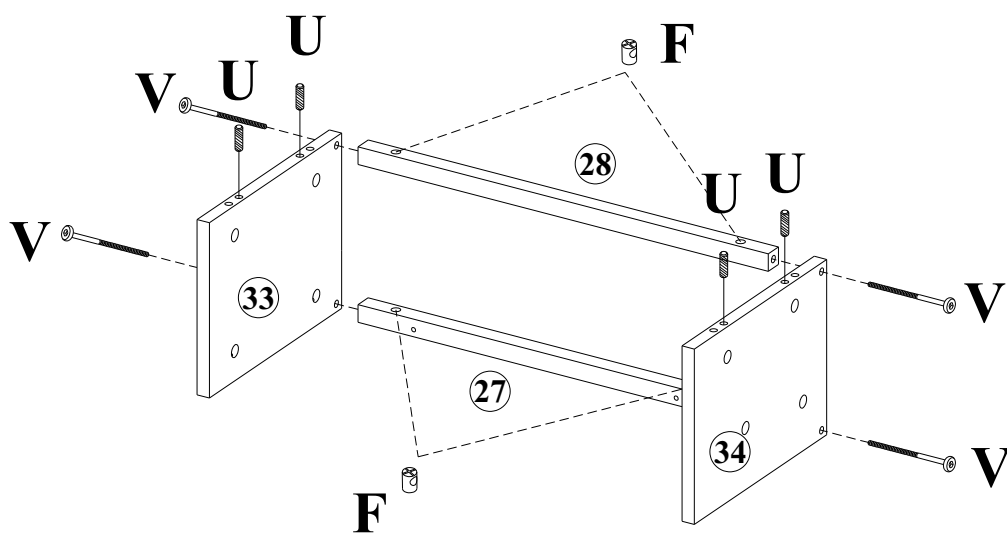

STEP: 22
(ÉTAPE: 22)



H

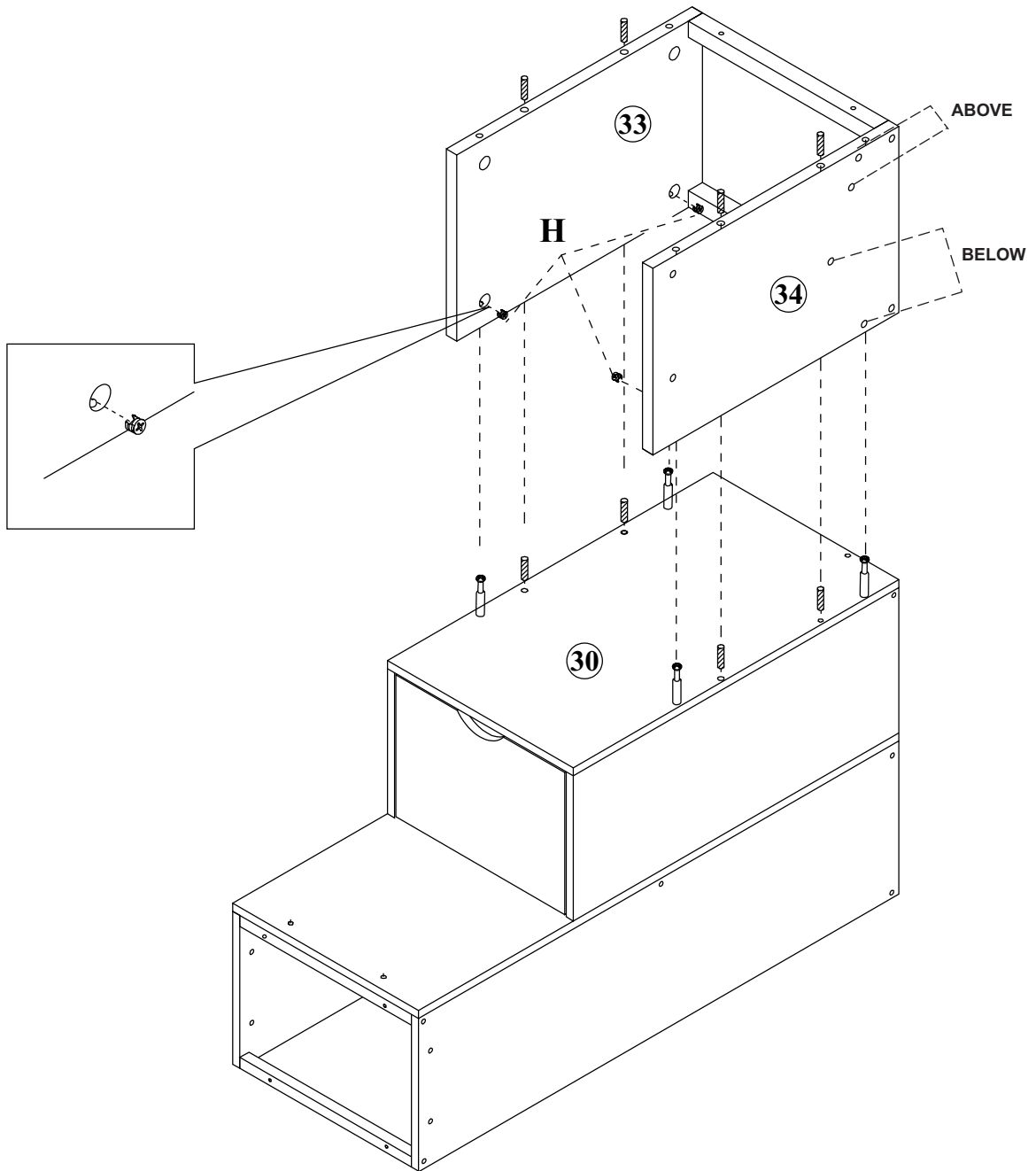

4 PCS

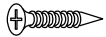

STEP: 23
(ÉTAPE: 23)

| | | | |
|---|---|---|---|
| C | H | Q | R |
|  |  |  |  |
| 2 PCS | 4 PCS | 2 PCS | 8 PCS |

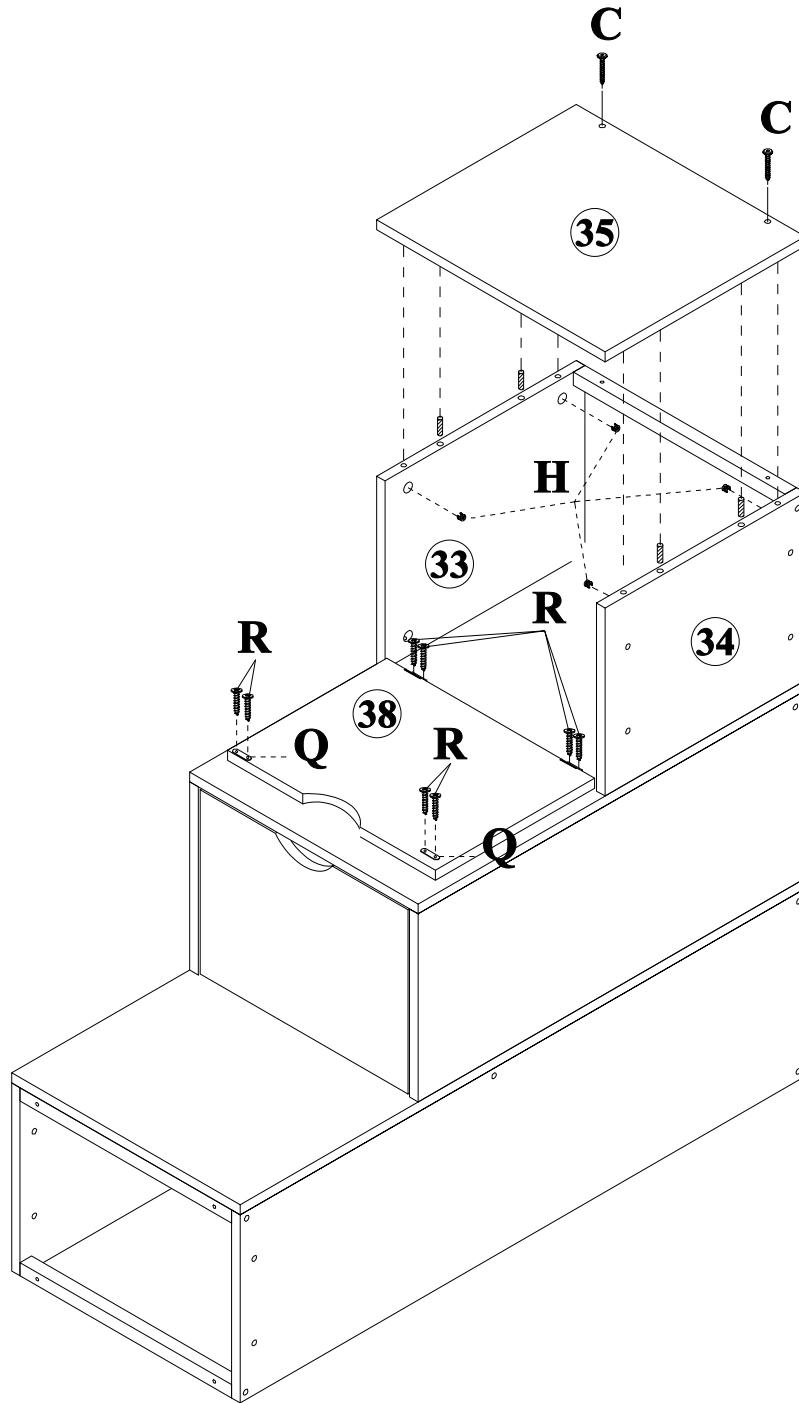

STEP: 24
(ÉTAPE: 24)

C



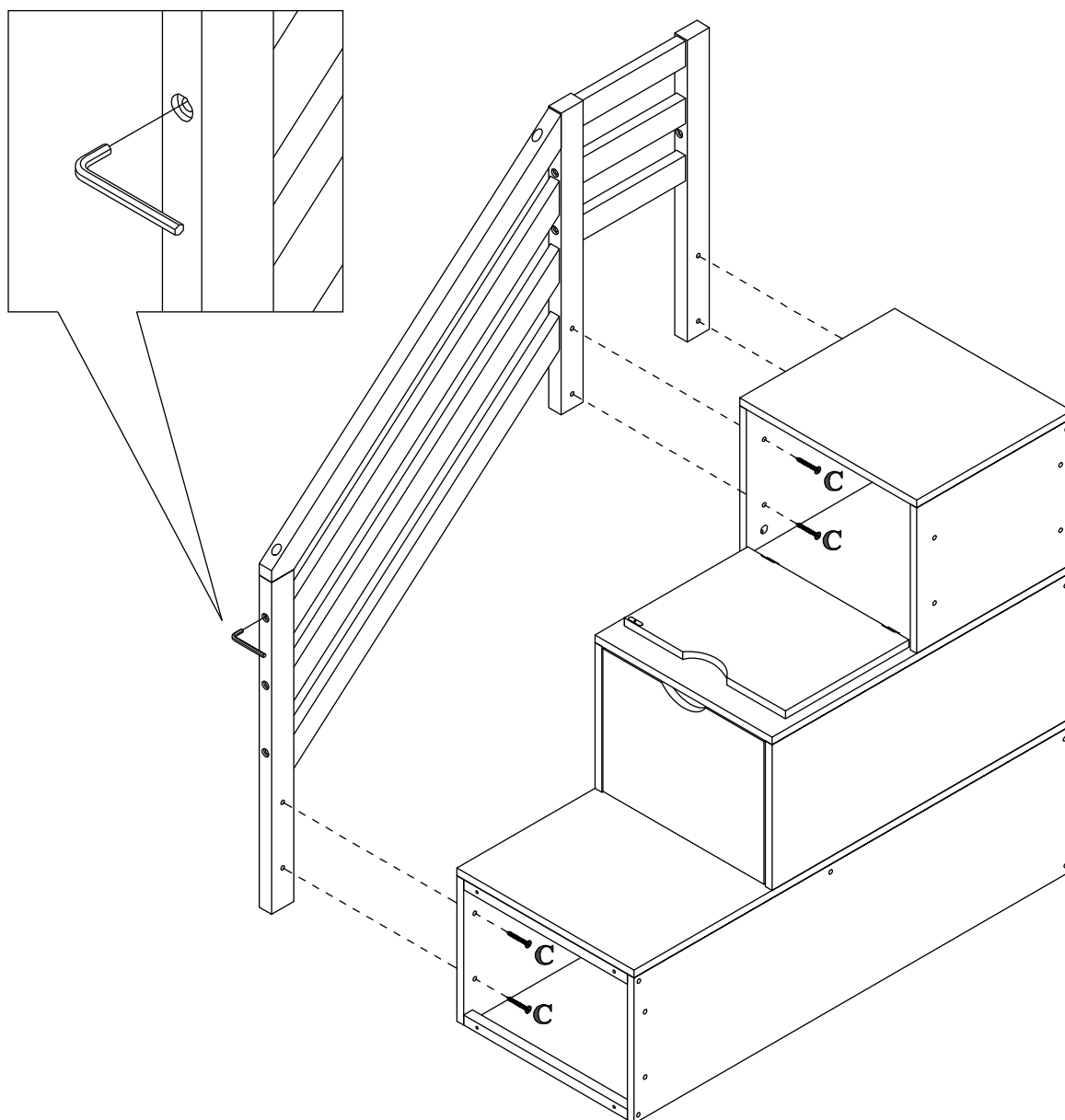

6 PCS





Note: First assemble everything together, then tighten all at.
Remarque : Assemblez d'abord tout, puis serrez toutes les pièces.

STEP: 25
(ÉTAPE: 25)

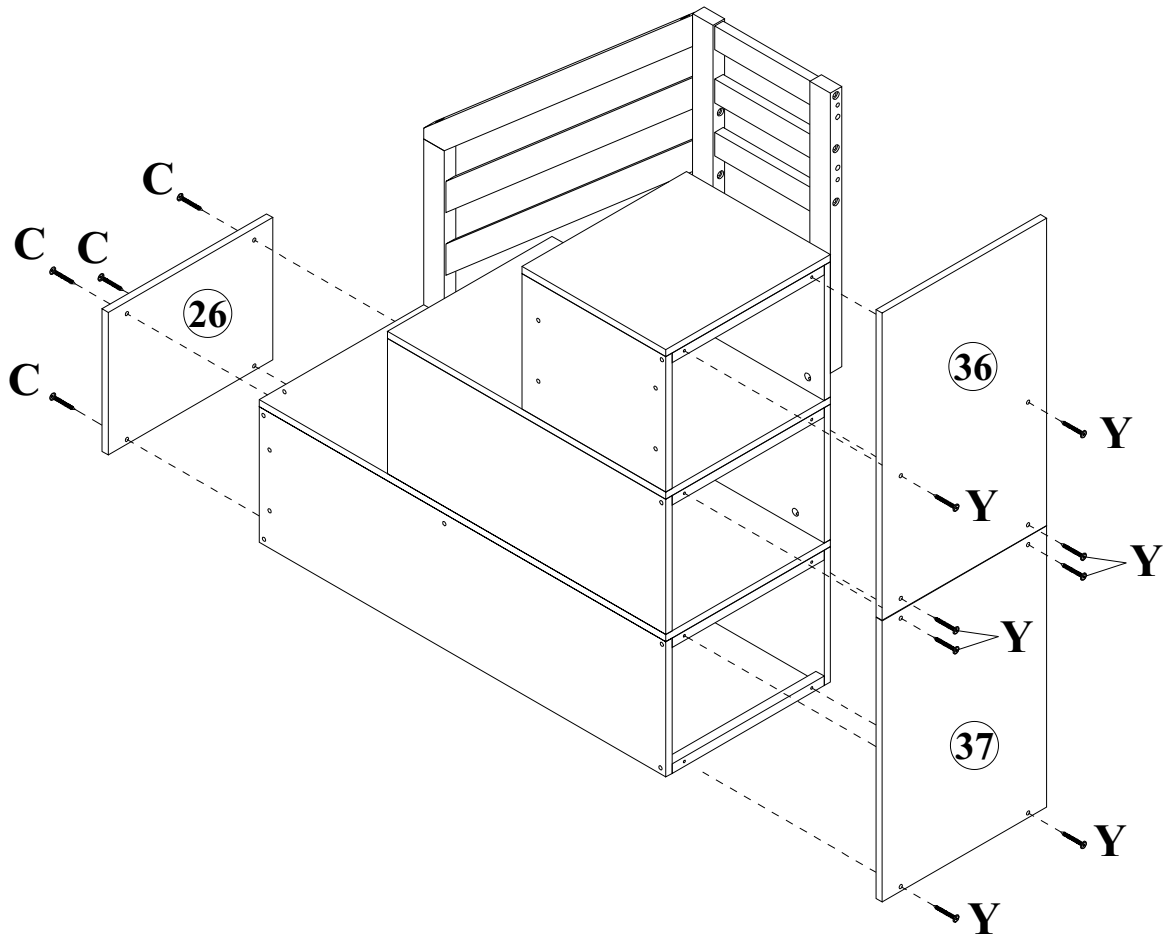
| | |
|---|---|
| C | Y |
|  |  |
| 4 PCS | 8 PCS |

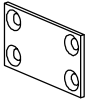

STEP: 26
(ÉTAPE: 26)

| | | | |
|--------------|---|---------------|---|
| M |  | N |  |
| 3 PCS | | 12 PCS | |

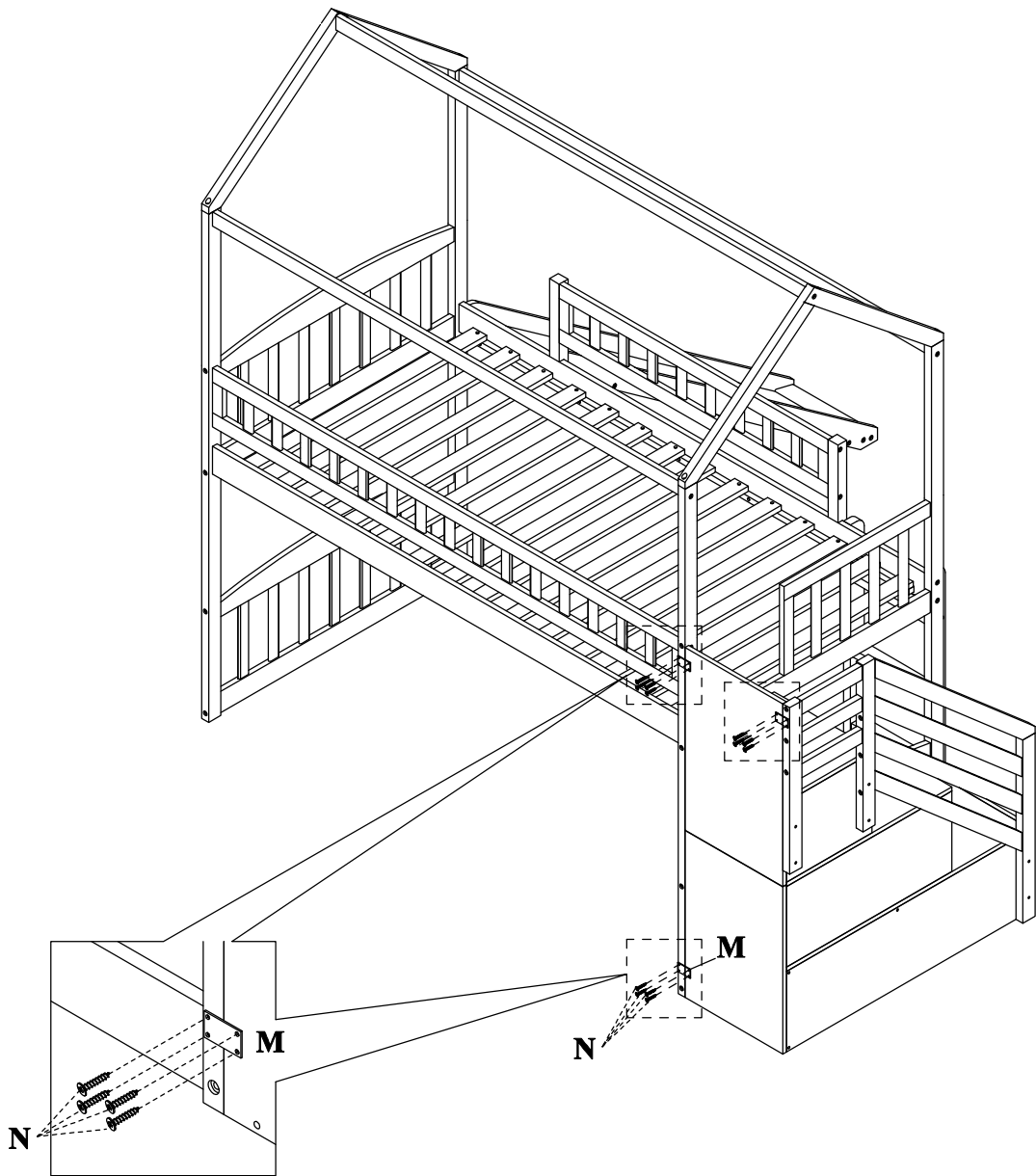

STEP: 27
(ÉTAPE: 27)

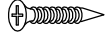
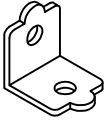
| | |
|---|---|
| N | L |
|  |  |
| 2 PCS | 1 PC |

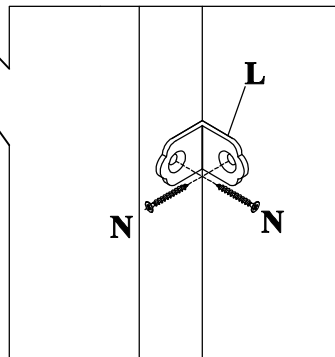
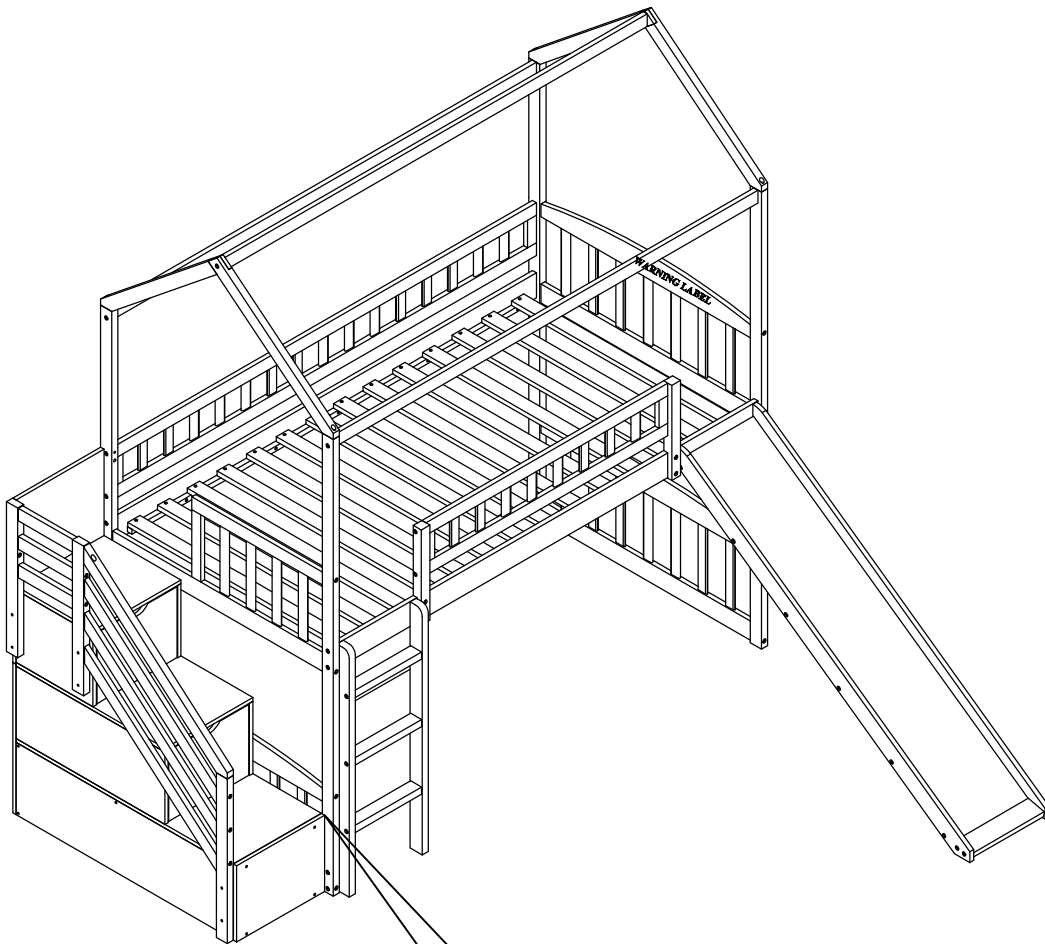

STEP:28
(ÉTAPE: 28)

