

Assembly Instruction

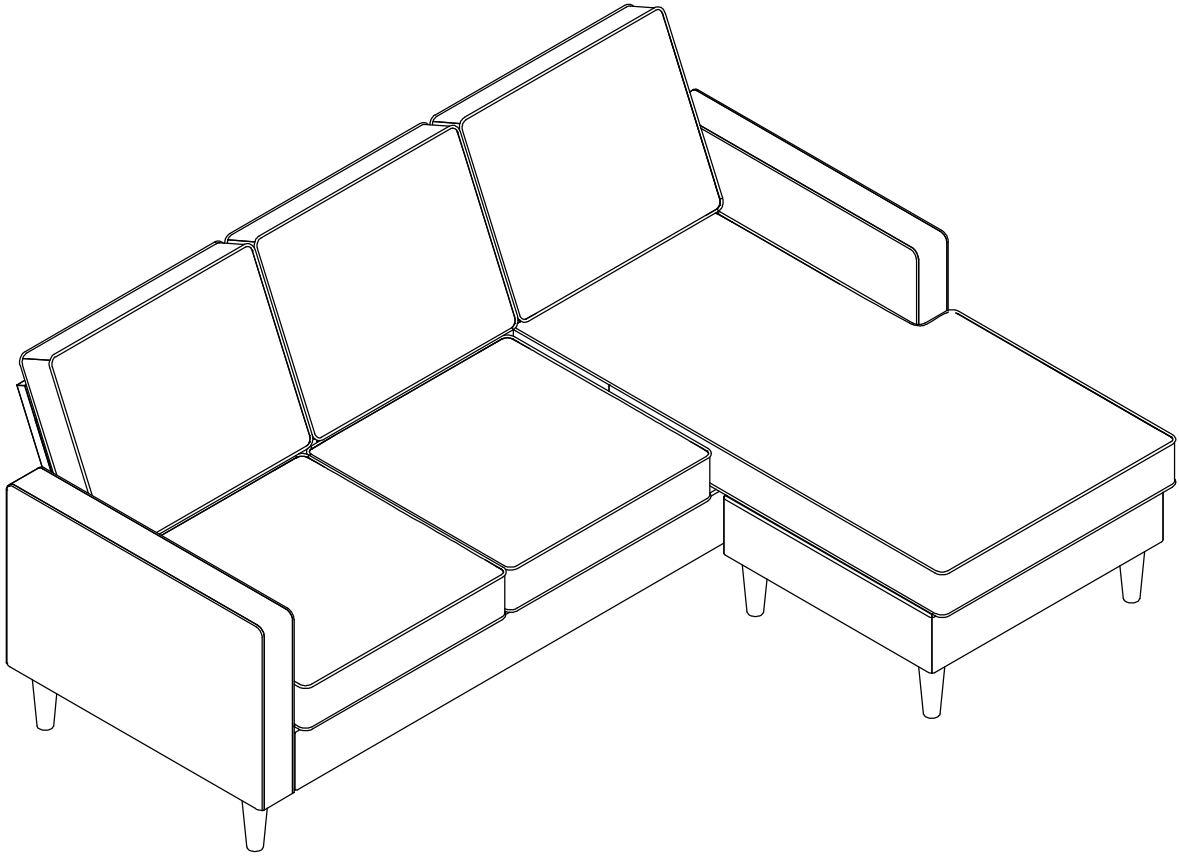

PART

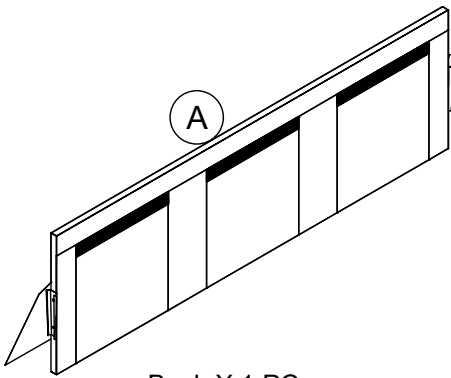

Back X 1 PC

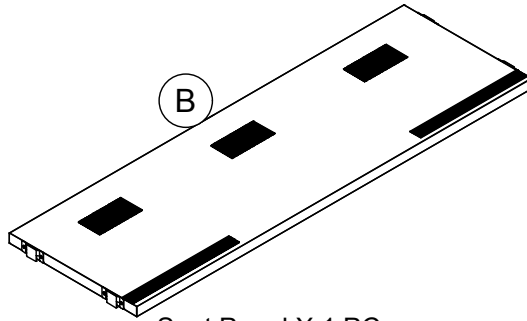

Seat Panel X 1 PC

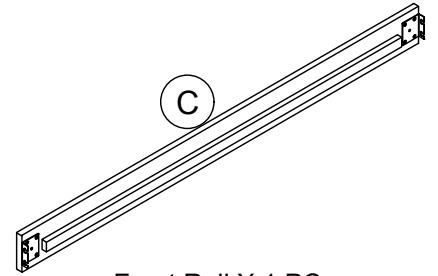

Front Rail X 1 PC

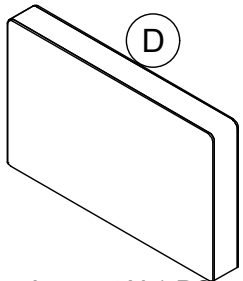

Armrest X 1 PC

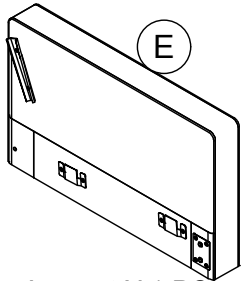

Armrest X 1 PC

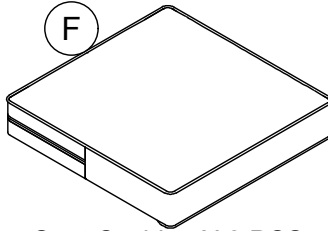

Seat Cushion X 2 PCS

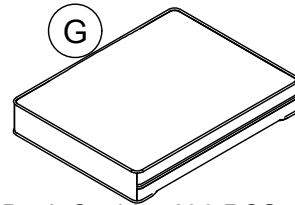

Back Cushion X 3 PCS

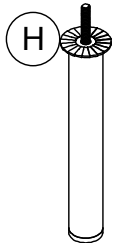

Support Leg X 1 PC

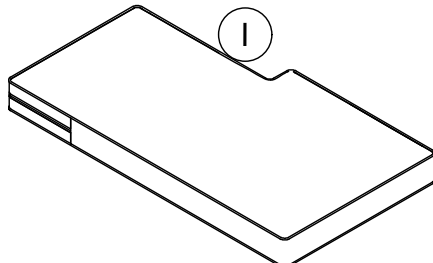

Long Seat Cushion X 1 PC

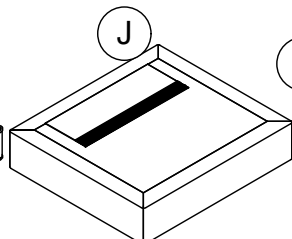

Ottoman X 1 PC

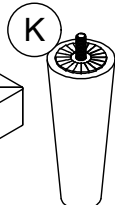

Leg X 8 PCS

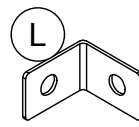

Bracket X 2 PCS

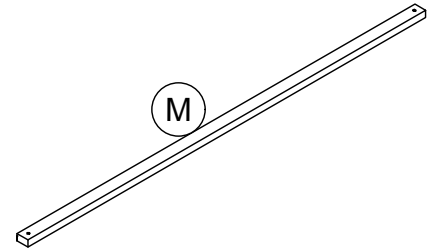

Rail X 1 PC

HARDWARE

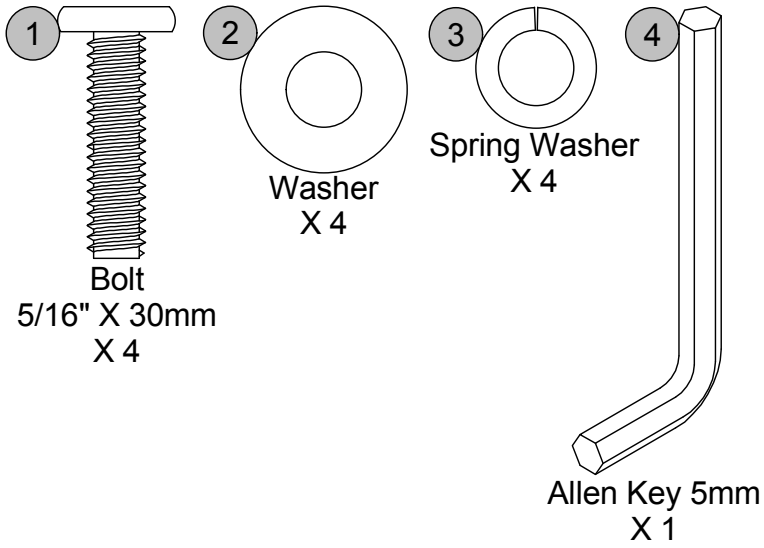

Step 1:

1.1 Manually screw **K** x 4 to **D** & **E**.

1.2 Manually screw **K** x 4 to **J**, as shown.

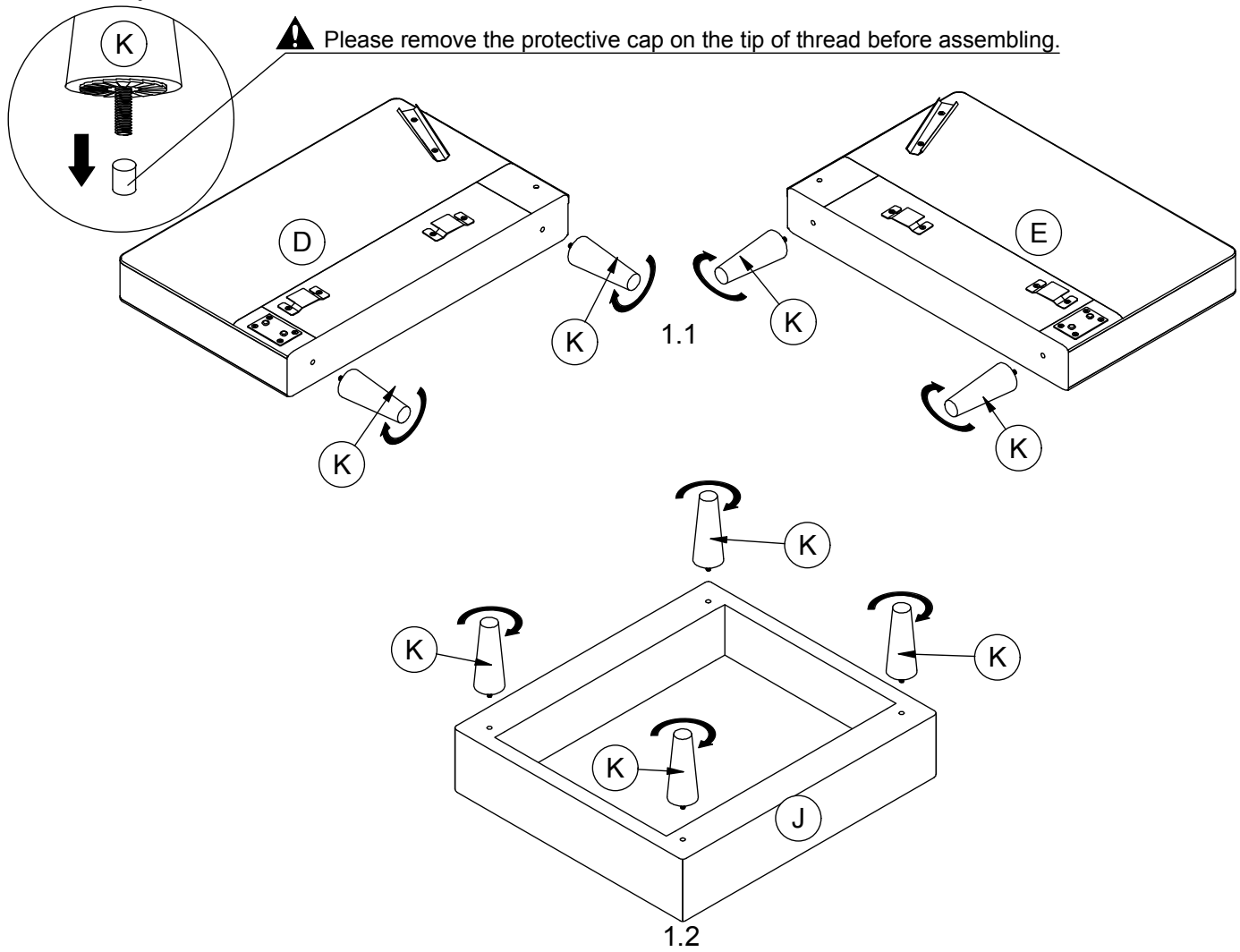

Step 2:

Attach **C** to **D** & **E** by inserting the brackets on **C** into the metal plate on **D** & **E**, as shown. Push **C** with a downward force to secure it into place.

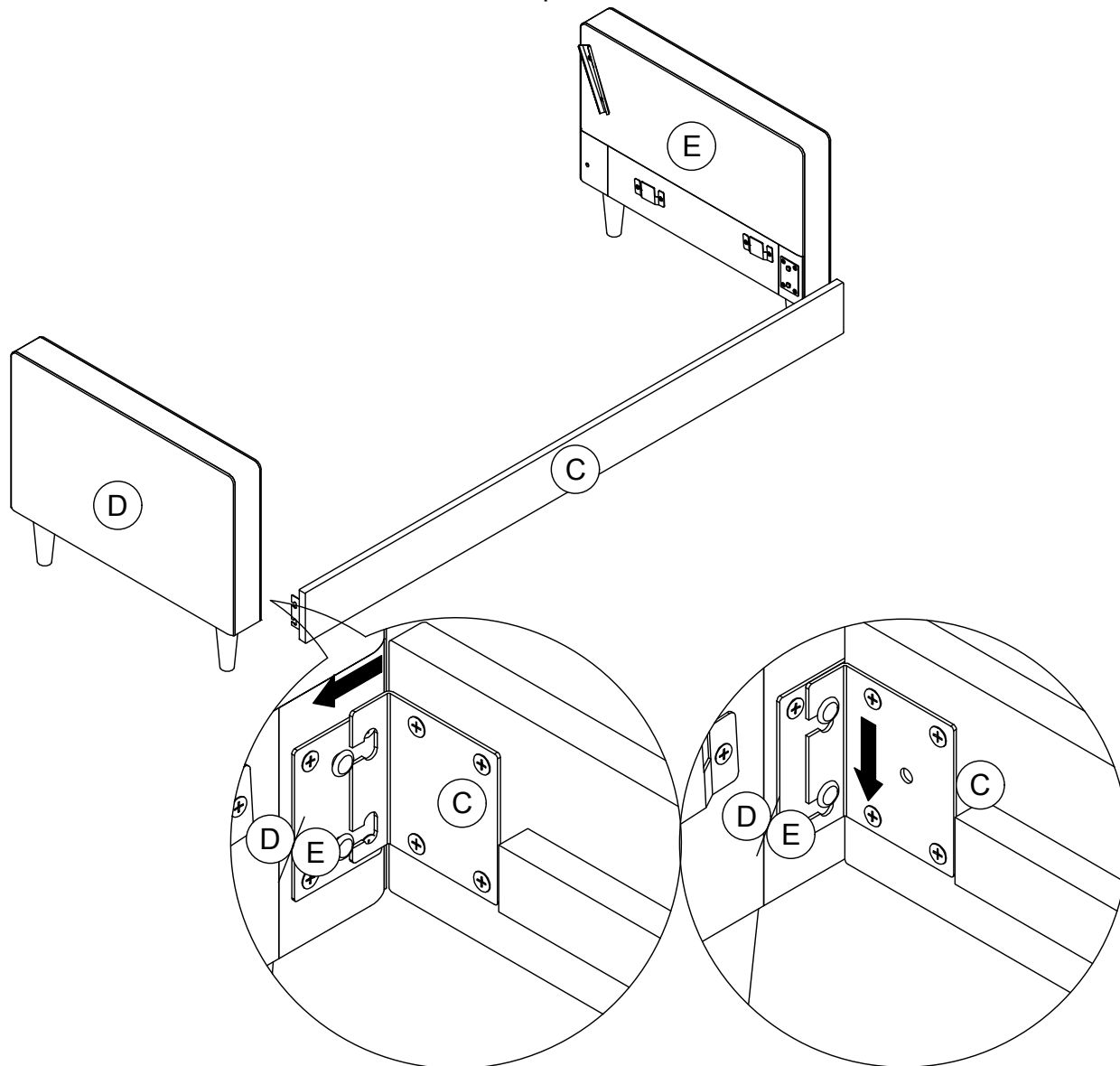

Step 3:

Manually screw **H** to **B**, as shown.

⚠ Please remove the protective cap on the tip of thread before assembling.

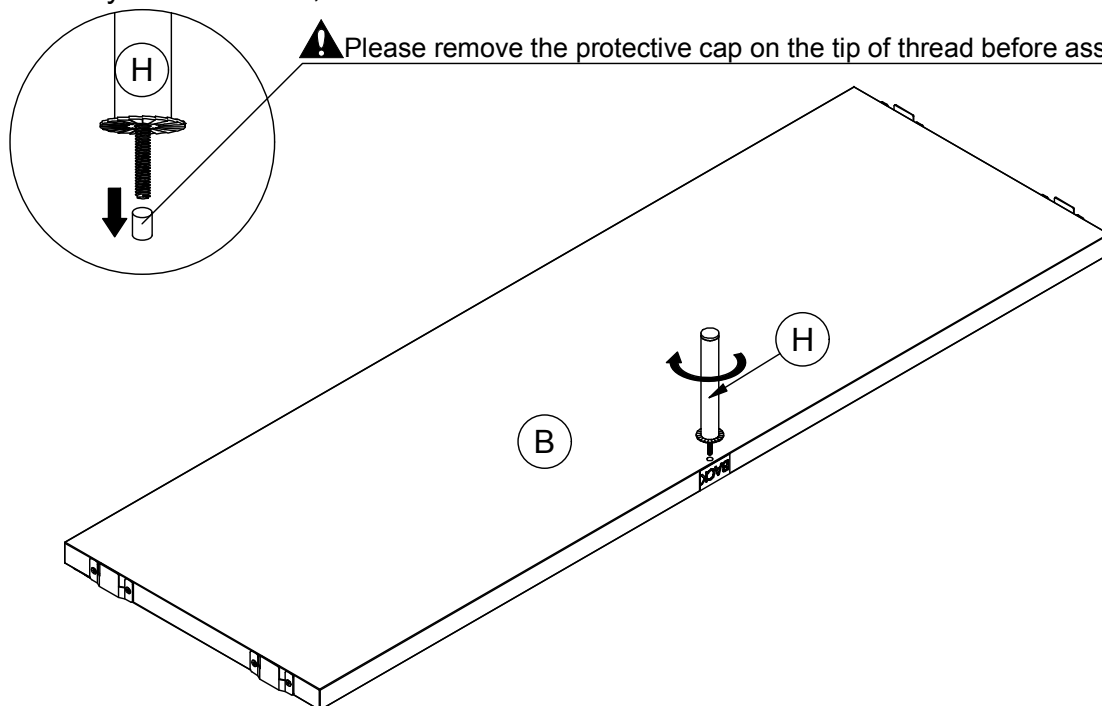

Step 4:

Attach **B** to **D** & **E** by inserting the metal brackets on **B** into the metal glides on **D** & **E**, as shown. Push **B** with a downward force to secure it into place.

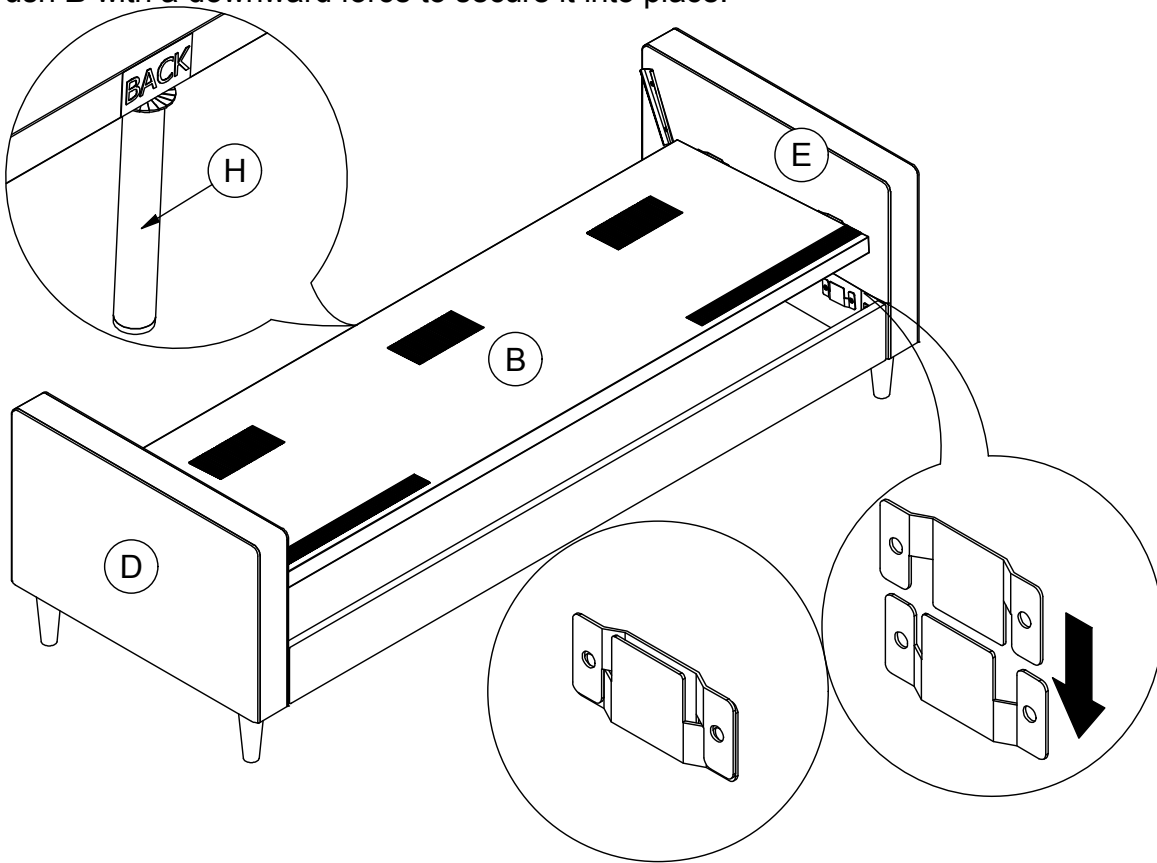

STEP 5:

Attach **L** x 2 to **M** with **1**, **2**, **3**, as shown.

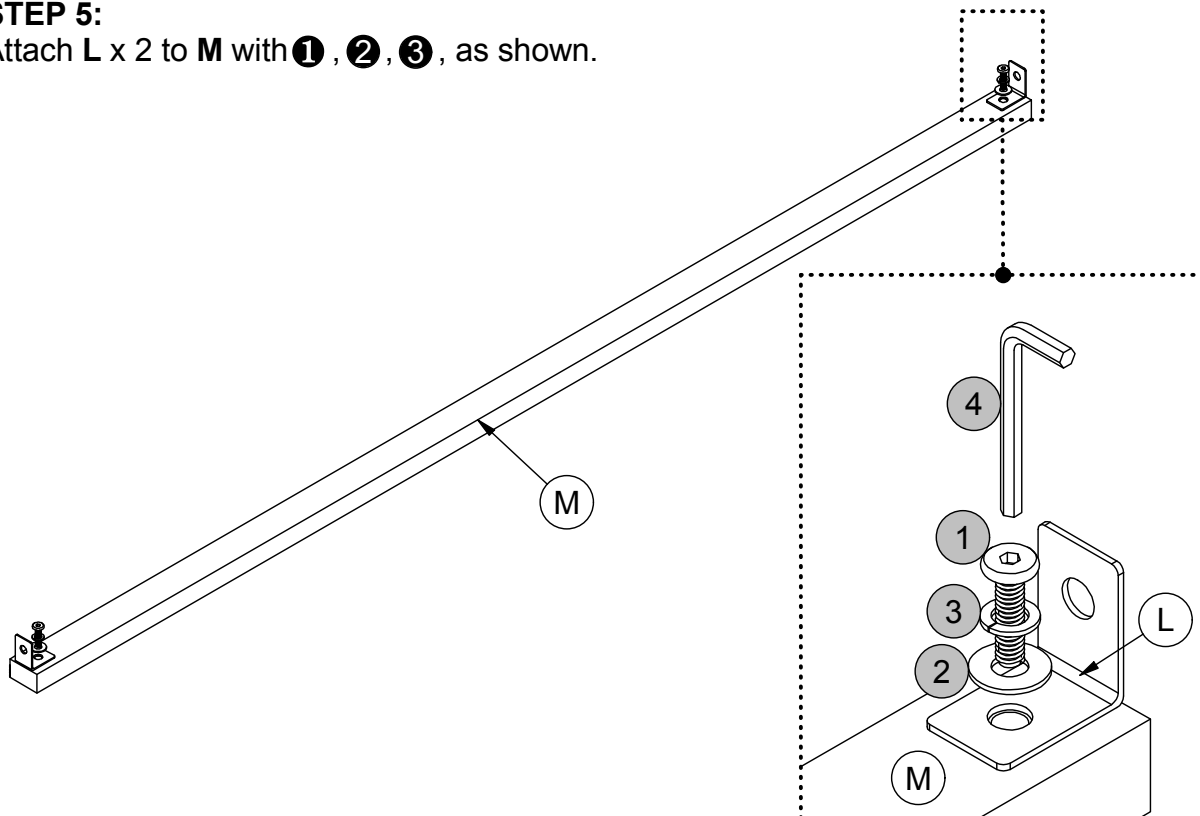

STEP 6:

Attach **M** to **D** & **E** with **1**, **2**, **3**, as shown.

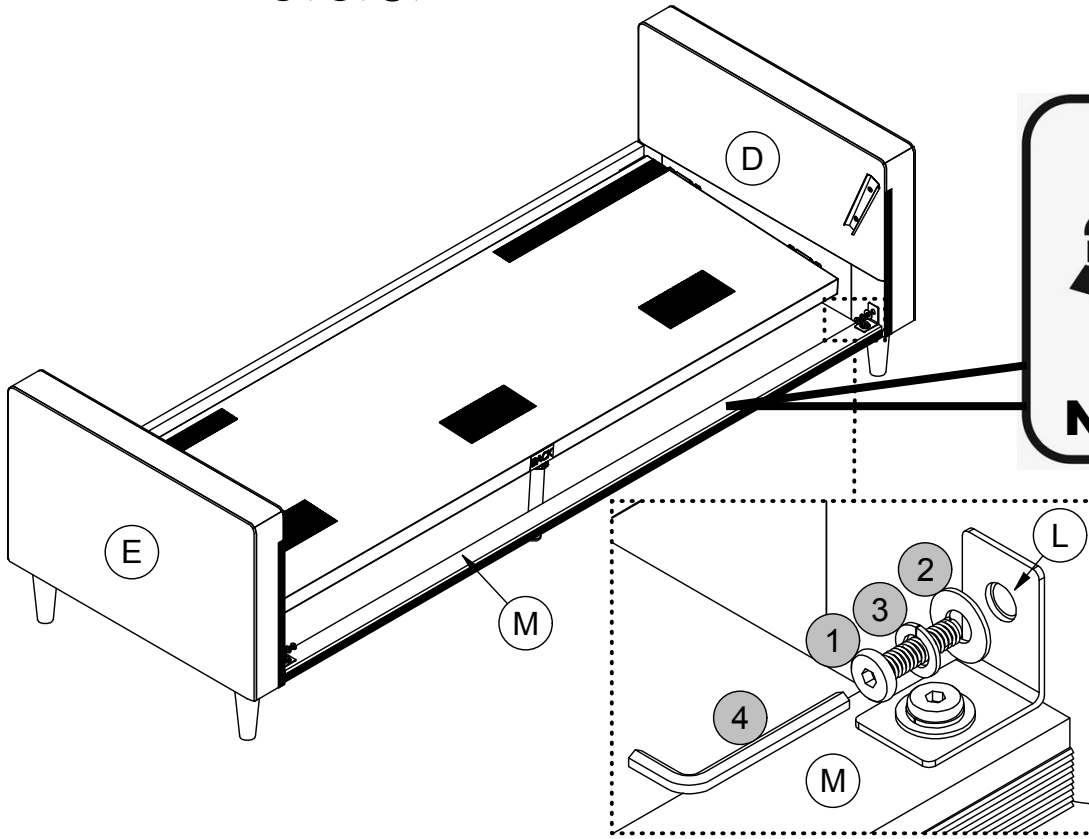

Step 7:

7.1 Attach **A** to **D** & **E** by inserting the brackets on **A** into the metal glides on **D** & **E**. Push **A** with a downward force to secure it into place.

7.2 Secure the fabric flap on **A** to **D**, **E** & **M** using the velcro strips.

⚠ Note: Both sides must be inserted at the same time. This step is best performed with 2 people.

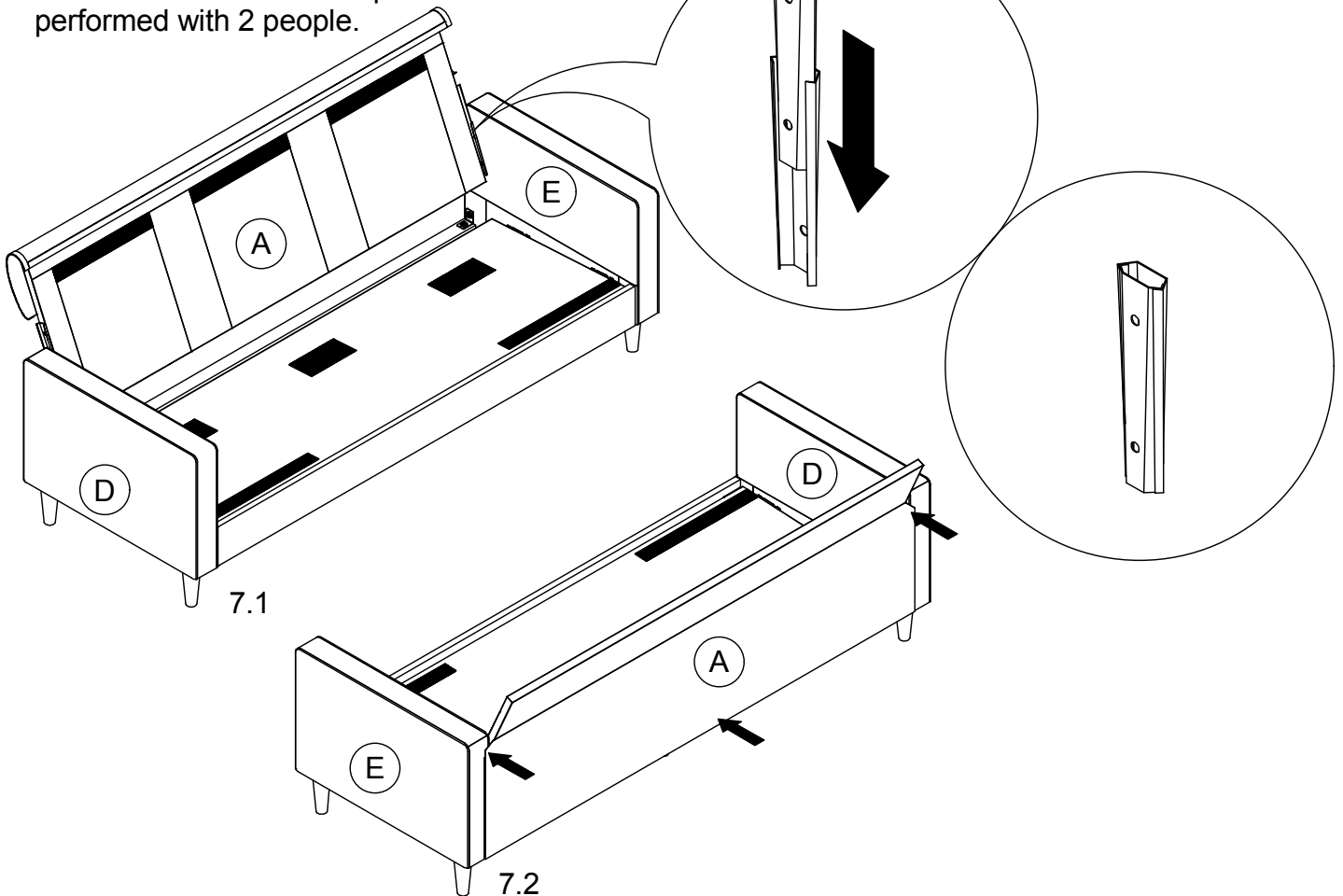

Step 8:

8.1 Place **J** in front of the assembled sofa using the velcro strips.

8.2 Remove the seat cushions from their vacuum sealed package.

Place **F** x 2 , **G** x 3 & **I** onto the sofa.

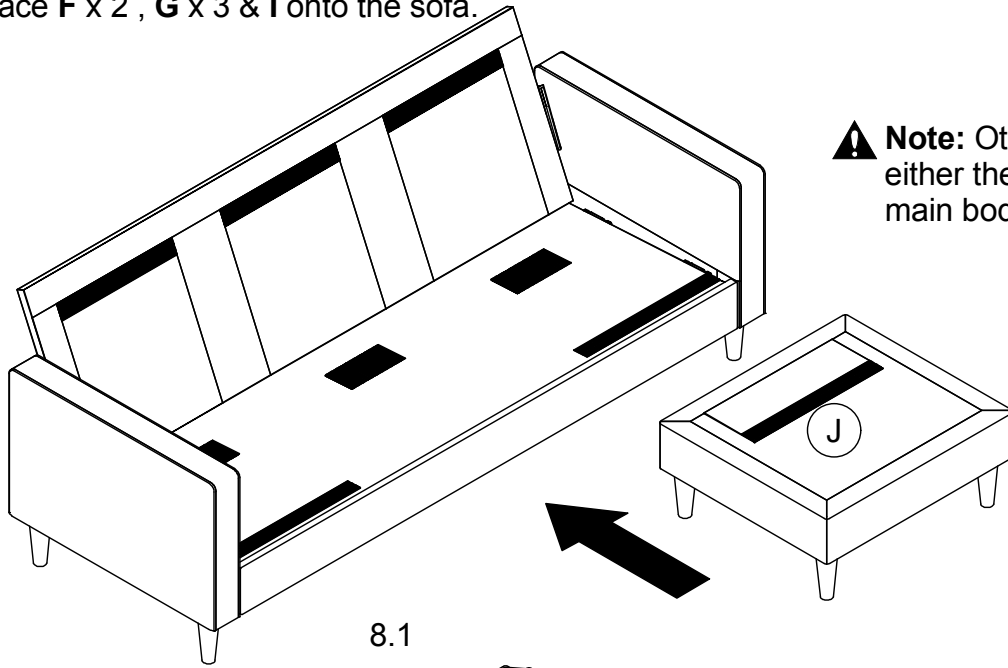

⚠ Note: Ottoman **J** can be placed on either the left or right side of the sofa main body.

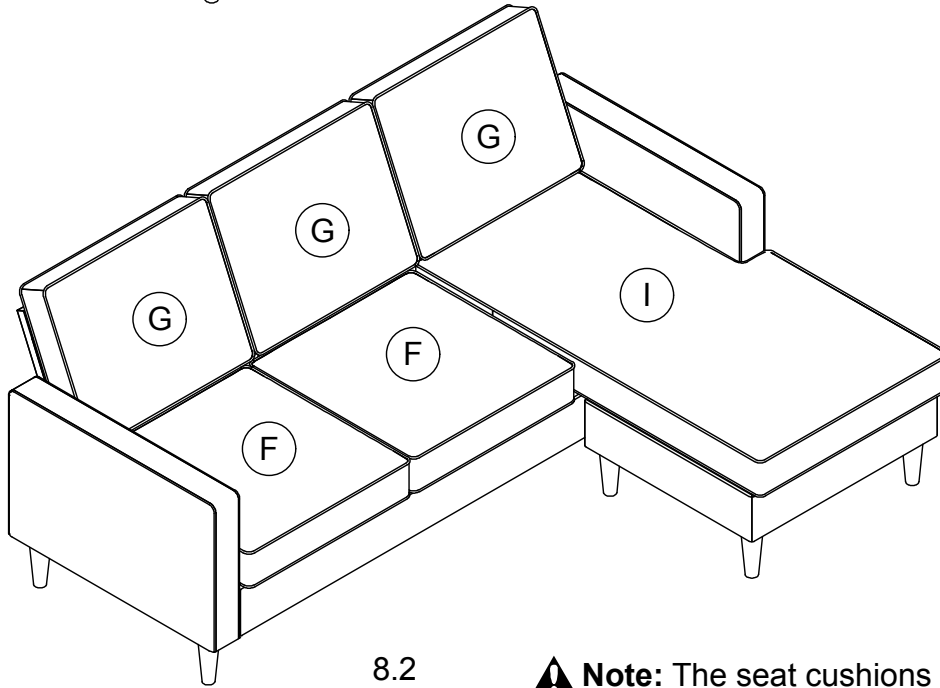

⚠ Note: The seat cushions have been vacuum packed for transportation purposes. After unpacking, please allow up to 72 hours so that they can return to their original shape.