

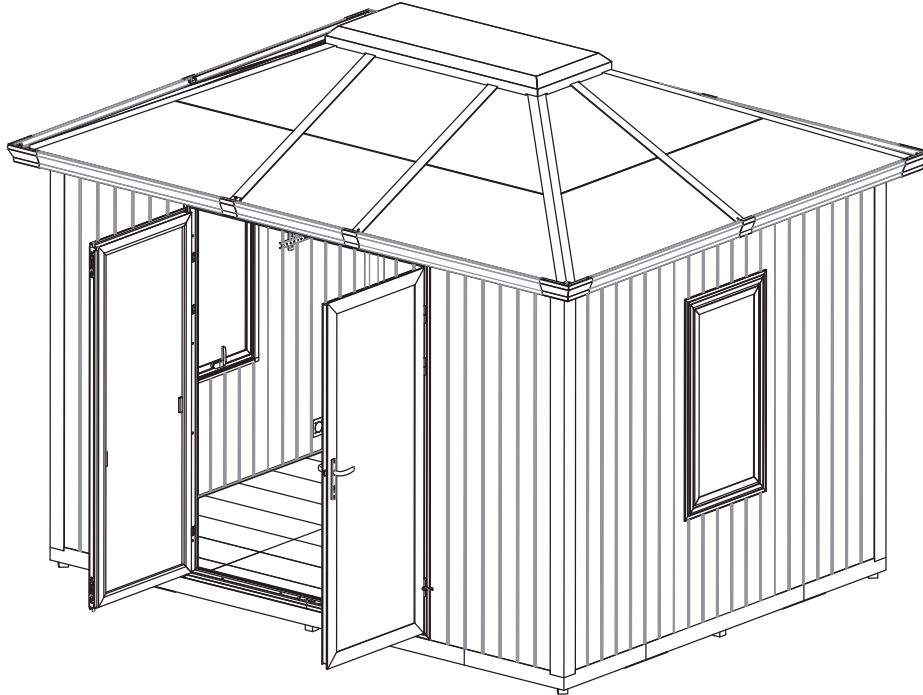

**Sunjoy Esquire, Beyond Shed, 10'x12.6' Backyard Office Shed,
Outdoor Storage Shed with Floors, 2 Windows, and Lockable Doors
Item #: A108000702**



***Questions? Issues? Missing Part? Professional
Installation Service?***



Please scan this QR code for assembly video and other helpful videos.



A10800070023



WARNINGS AND PRE-ASSEMBLY CONSIDERATIONS:

- Please read the instructions before assembly!
- Before assembly ensure that your site is fully prepped and ready. A solid level foundation is required for this product. A level concrete pad or gravel shed foundation are suitable. DO NOT attempt to assemble on uneven ground, soil, sand, grass, wood plank, etc.
- Check to ensure all parts are present prior to assembly.
- This product is heavy. It requires a minimum of 4 adults for safe assembly. Do not attempt to assemble alone.
- Keep all children and pets away during the assembly process.
- Keep assembly area more than 1.8 m / 5.9 ft from any obstruction such as a fence, garage, house, overhanging branches, laundry line or electrical wires.
- Some parts may contain sharp edges. Basic safety precautions should always be followed to reduce the risk of personal injury or damage to the product.
- Protect parts during assembly by laying them on a non-abrasive surface such as blankets or cardboard.
- Double Check all bolts or screws that they are secured and tight before use. Periodically tighten bolts and screws.

CARE AND MAINTENANCE INSTRUCTIONS:

- Galvanized Steel components for this gazebo are treated with rust inhibiting paint that protects it from rusting. However, due to the nature of steel, surface oxidation (rusting) will occur if these protective coatings are scratched. This is not a defect and thus not covered by the warranty.
- To minimize this condition, it is recommended to use care when assembling and handling the product to prevent scratching the paint. Should any scratching or damage occur, it is recommended to cover the scratch immediately with rust inhibiting paint (not included).
- Surface rust can also be easily removed with a very light application of WD-40. If surface oxidation (rusting) occurs and no measure is taken to prevent this, the oxidation may start dripping onto deck or patio causing stains, which may be difficult to remove. This can be prevented if the above-mentioned measures are utilized.
- Do not use bleach, acid, or other abrasive cleaners on the roof or frame parts.
- Keep instruction manual for future reference.
- Keep your original receipt to maintain and your warranty for replacement parts.
- Do not allow excess snow to collect on the roof. To avoid damage/scratches carefully remove any snow/ice with a non-abrasive (flexible plastic) snow rake.

ONE-YEAR LIMITED WARRANTY

This limited warranty is extended to the original purchaser and applies to defects in material and workmanship of your item provided the item is maintained with care and used only for personal, residential purposes. The manufacturer warrants this item is free of defects in material and workmanship for a period of two years. If any defect is found, please email at customer.care@sunjoygroup.com for help. email at customer.care@sunjoygroup.com for help. The manufacturer will not cover transportation or delivery costs or compensate the individual or any outside party for assembling or disassembling the product. The manufacturer will not cover transportation or delivery costs or compensate the individual or any outside party for assembling or disassembling the product.

Safety Items recommended (Not Included)



Tools recommended (Not Included)

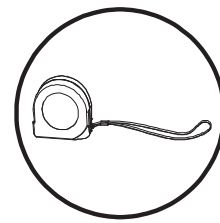
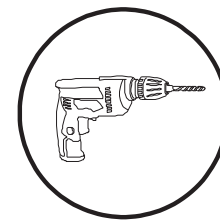
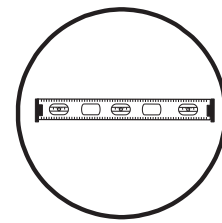
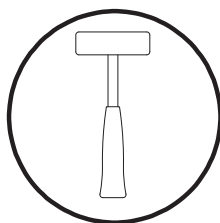
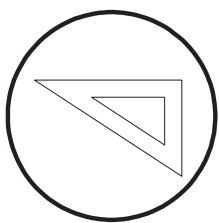
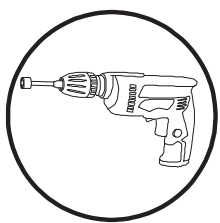
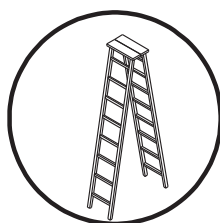
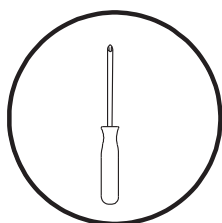
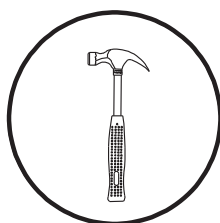

ATTENTION: ONLY ATTEMPT TO ASSEMBLE THIS PRODUCT ON A STRONG LEVEL FOUNDATION, SUCH AS A PROFESSIONALLY INSTALLED CONCRETE PAD OR GRAVEL SHED FOUNDATION.





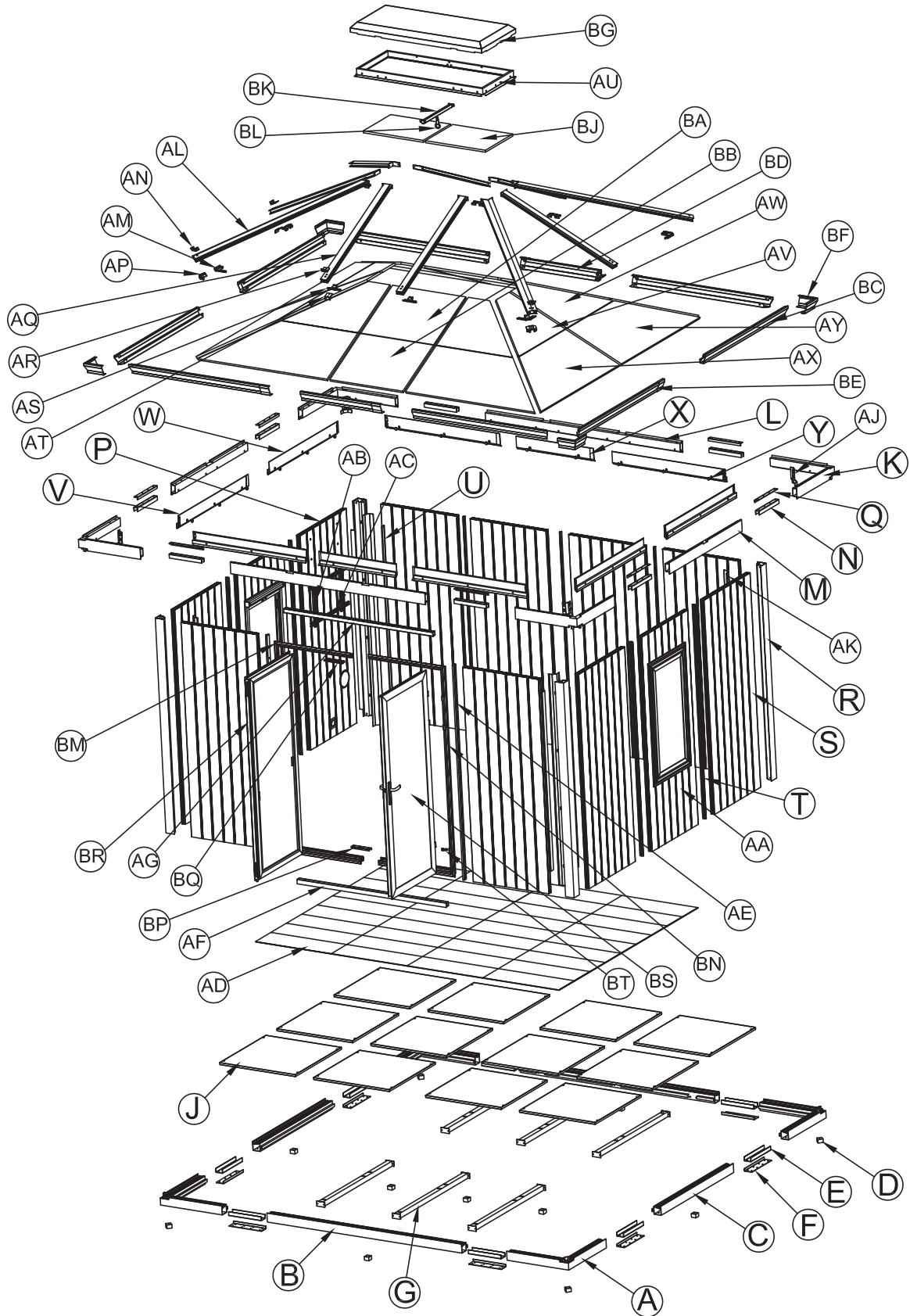





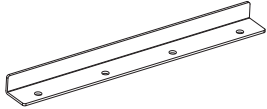



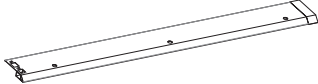
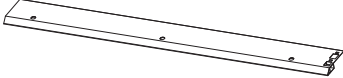
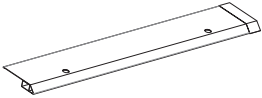
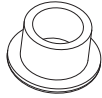
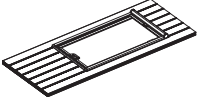
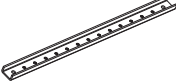
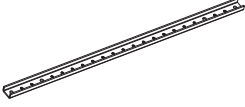

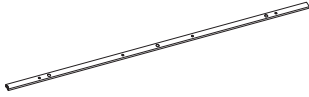
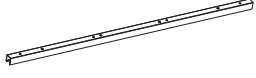
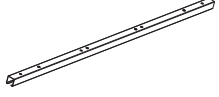

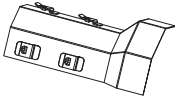
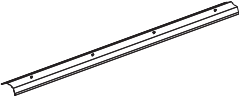
Exploded Drawing

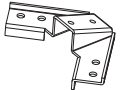
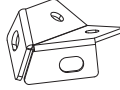
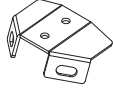

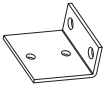

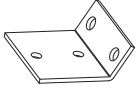
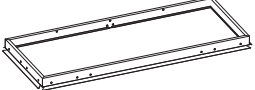

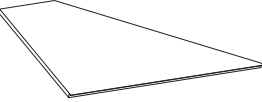
Parts List

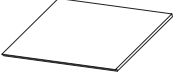

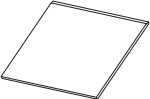
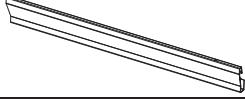
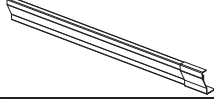
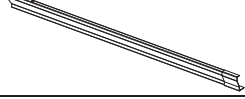

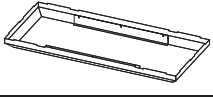
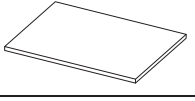
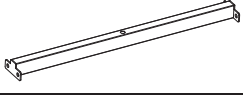

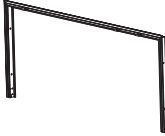
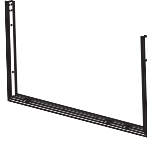
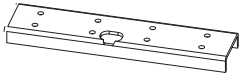
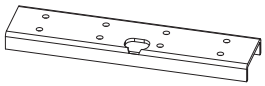
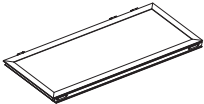
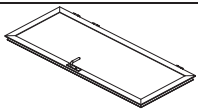
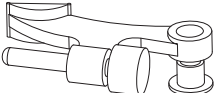
| Label | Part Number | Description | Qty | Part Image |
|-------|--------------|-----------------------------|-----|---|
| A | P00050218001 | Corner for base | 4 |  |
| B | P00040170701 | Long base beam | 2 |  |
| C | P00040170801 | Short base beam | 2 |  |
| D | P00540075301 | Plastic feet | 11 |  |
| E | P00050218101 | U-connector for base | 8 |  |
| F | P00050218201 | L-connector for base | 8 |  |
| G | P00040170901 | Floor joist | 6 |  |
| J | P00500087601 | Floor reinforcement board | 12 |  |
| K | P00050218301 | Corner for top frame | 4 |  |
| L | P00040171001 | Long beam for top frame | 2 |  |
| M | P00040171101 | Short beam for top frame | 2 |  |
| N | P00050218501 | U-connector for top frame | 8 |  |
| P | P00240008302 | Wall with pre-drilled holes | 1 |  |

| | | | | |
|----|--------------|---------------------------|----|---|
| Q | P00050218401 | L-connector for top frame | 8 |  |
| R | P00020089501 | Corner post | 4 |  |
| S | P00240008402 | Wall | 9 |  |
| T | P00050218601 | Wall connector | 7 |  |
| U | P00560057101 | Gap filler | 8 |  |
| V | P00220045701 | Secure plate 1 for wall | 4 |  |
| W | P00220045801 | Secure plate 2 for wall | 4 |  |
| X | P00220045901 | Secure plate 3 for wall | 2 |  |
| Y | H990010029 | Screw cap | 28 |  |
| AA | P00240008502 | Wall with window | 2 |  |
| AB | P00760025401 | TV mount 1 | 2 |  |
| AC | P00760025501 | TV mount 2 | 2 |  |
| AD | P00430015501 | SPC floor | 36 |  |
| AE | P00500087701 | Side support for door | 2 |  |
| AF | P00500087801 | Bottom support for door | 1 |  |
| AG | P00500087901 | Upper support for door | 1 |  |

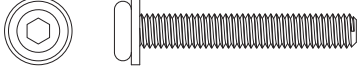
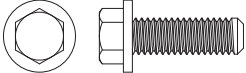
| | | | | |
|----|--------------|--------------------|---|---|
| AJ | P00560057201 | Corner cover plate | 4 |  |
| AK | P00560057301 | Corner post cover | 4 |  |
| AL | P00060301701 | inclined roof beam | 4 |  |
| AM | P00050218701 | Connector 1 | 4 |  |
| AN | P00050218801 | Connector 2 | 4 |  |
| AP | P00050218901 | Connector 3 | 4 |  |
| AQ | P00060301801 | Middle roof beam | 6 |  |
| AR | P00050219001 | Connector 4 | 6 |  |
| AS | P00050219101 | Connector 5 | 6 |  |
| AT | P00050219201 | Connector 6 | 6 |  |
| AU | P00050219301 | Center roof frame | 1 |  |
| AV | P00070145601 | Roof heat shield 1 | 4 |  |
| AW | P00070145701 | Roof heat shield 2 | 4 |  |
| AX | P00070145801 | Roof heat shield 3 | 4 |  |
| AY | P00070145901 | Roof heat shield 4 | 4 |  |
| BA | P00070146001 | Roof heat shield 5 | 2 |  |

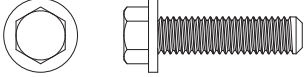
| | | | | |
|----|--------------|--------------------------|---|---|
| BB | P00070146101 | Roof heat shield 6 | 2 |  |
| BC | P00040171201 | Right gutter | 4 |  |
| BD | P00040171301 | Middle gutter | 2 |  |
| BE | P00040171401 | Left gutter | 4 |  |
| BF | P00560057401 | Corner decoration | 4 |  |
| BG | P00090021901 | Center roof cover | 1 |  |
| BJ | P00070146201 | Roof heat shield 7 | 2 |  |
| BK | P00060301901 | Hook beam | 1 |  |
| BL | P00580019101 | Hook | 1 |  |
| BM | P00440001301 | Door frame with pin hole | 1 |  |
| BN | P00440001401 | Door frame w/o pin hole | 1 |  |
| BP | P00050219401 | Door frame connector 1 | 1 |  |
| BQ | P00050219501 | Door frame connector 2 | 1 |  |
| BR | P00410021601 | Door with latch | 1 |  |
| BS | P00410021701 | Door w/o latch | 1 |  |
| BT | P00220046001 | Door stopper | 2 |  |

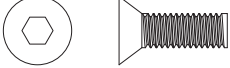
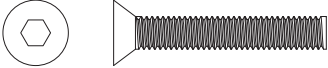
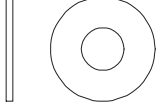
Hardware Pack

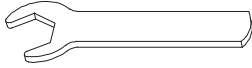
| Label | Part Number | Description | Qty | Spare | Part Image |
|-------|-------------|----------------|-----|-------|---|
| H1 | H100040023 | Bolt M6*40 | 98 | 5 |  |
| H2 | H100010097 | Bolt M6*20 | 296 | 15 |  |
| H3 | H040100037 | M6 Nut | 6 | 1 |  |
| H4 | H100010176 | Bolt M6*25 | 8 | 1 |  |
| H5 | H030180001 | Screw ST4.8*63 | 14 | 1 |  |
| H6 | H010050059 | Bolt M6*15 | 16 | 1 |  |
| H7 | H010050060 | Bolt M6*35 | 16 | 1 |  |
| H8 | H050070038 | Flat washer M6 | 6 | 1 |  |
| HW1 | H090030002 | Allen Key M6 | 1 | 0 |  |
| HW2 | H090010017 | Wrench M6 | 2 | 0 |  |

1

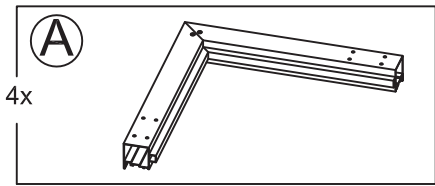

ATTENTION: ONLY ATTEMPT TO ASSEMBLE THIS PRODUCT ON A STRONG LEVEL FOUNDATION, SUCH AS A PROFESSIONALLY INSTALLED CONCRETE PAD OR GRAVEL SHED FOUNDATION.

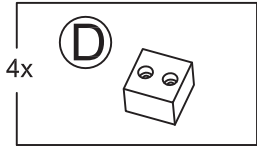
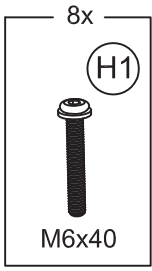

Install plastic feet (D) onto 4 base corners (A). Fully tighten these bolts (H1) after this step has been completed.

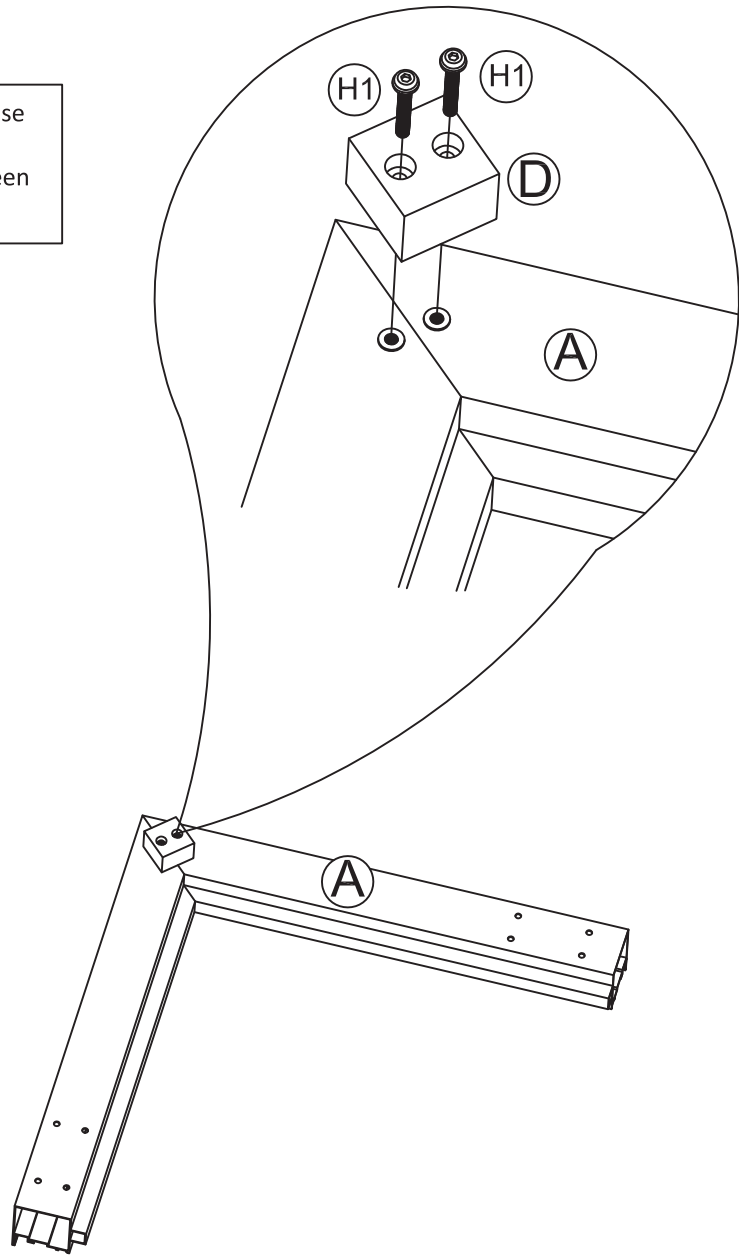

2

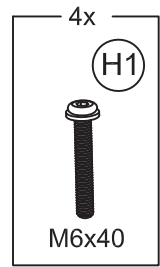
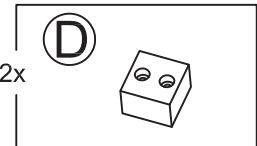
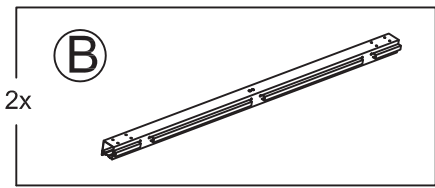

Install plastic feet (D) onto 2 long base beams (B). Fully tighten these bolts (H1) after this step has been completed.

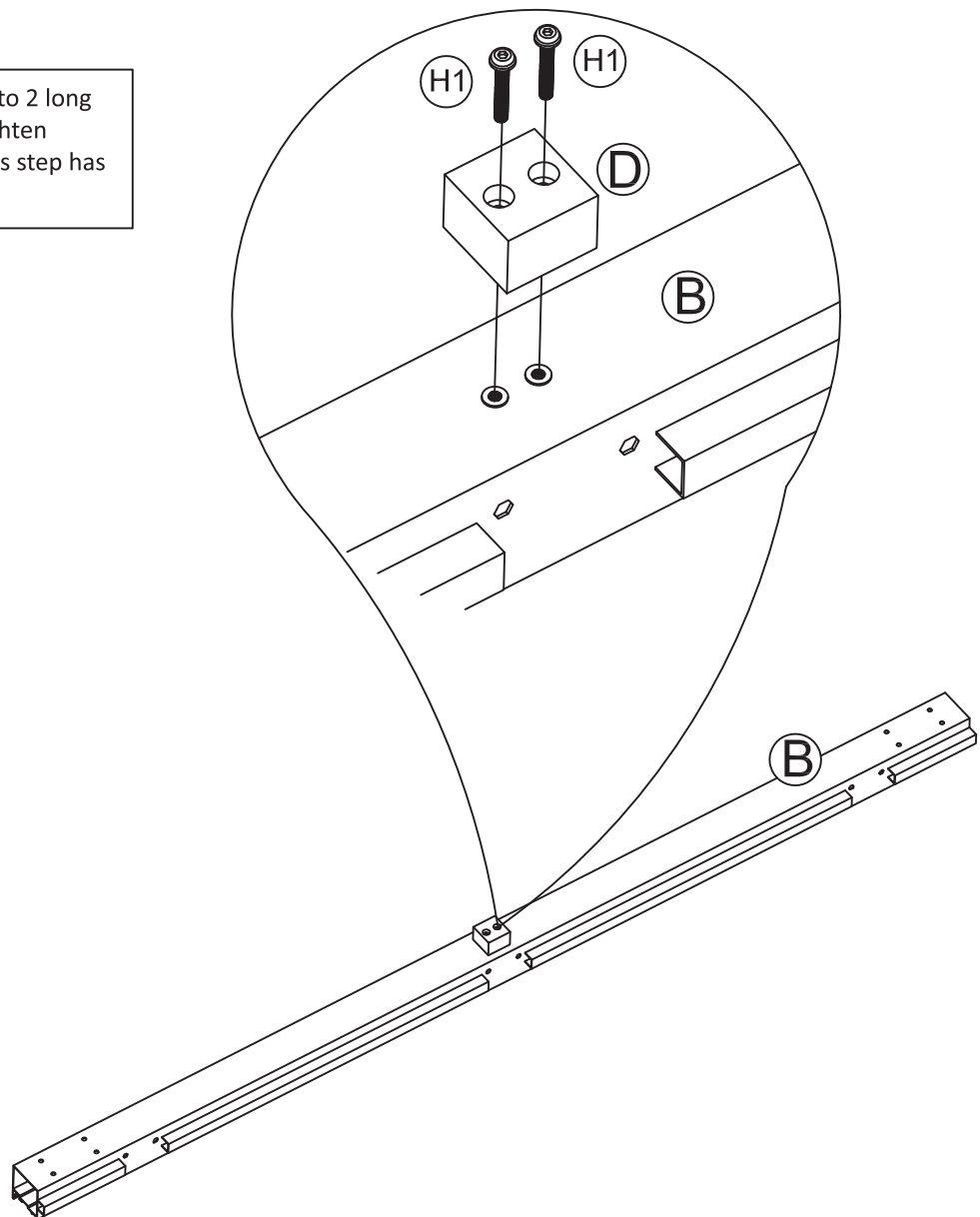

3

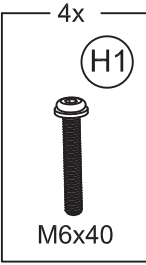
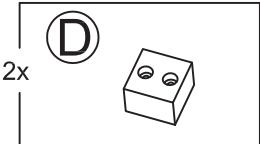
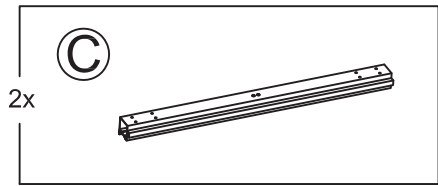

Install plastic feet (D) onto 2 short base beams (C). Fully tighten these bolts (H1) after this step has been completed.

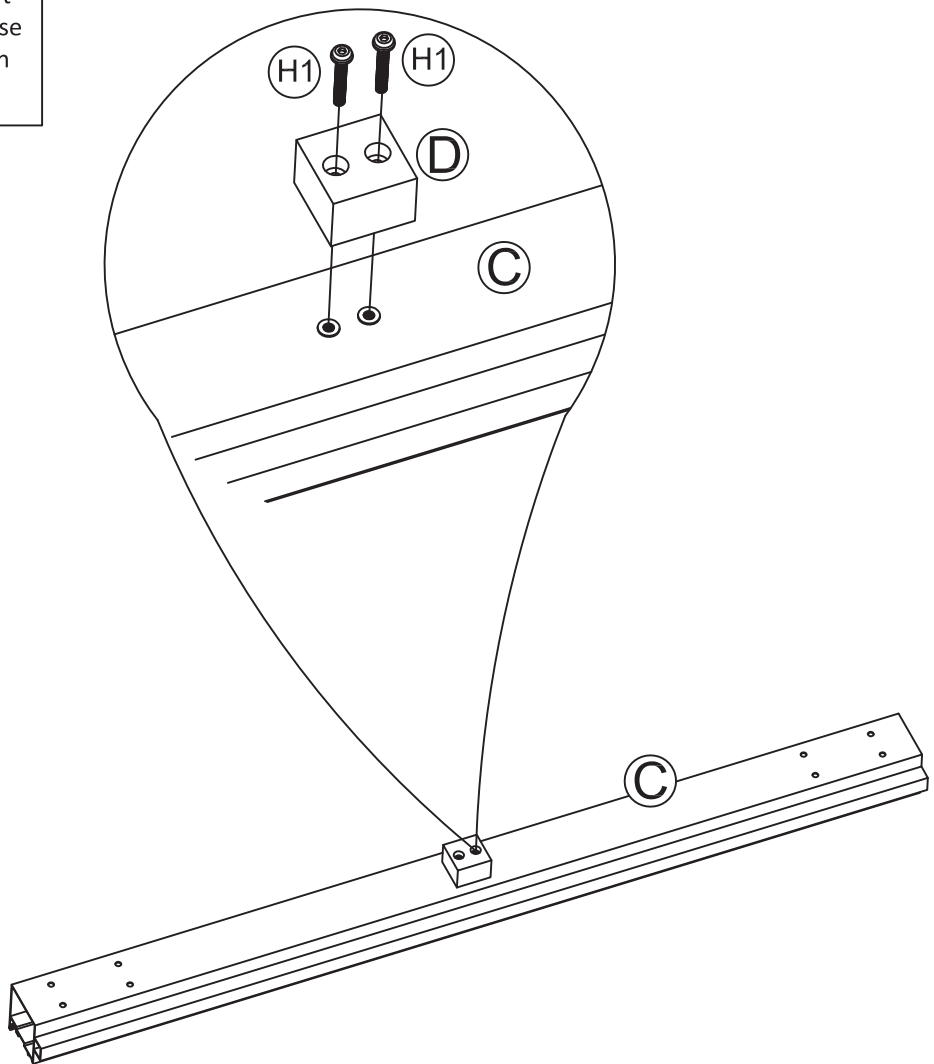

4

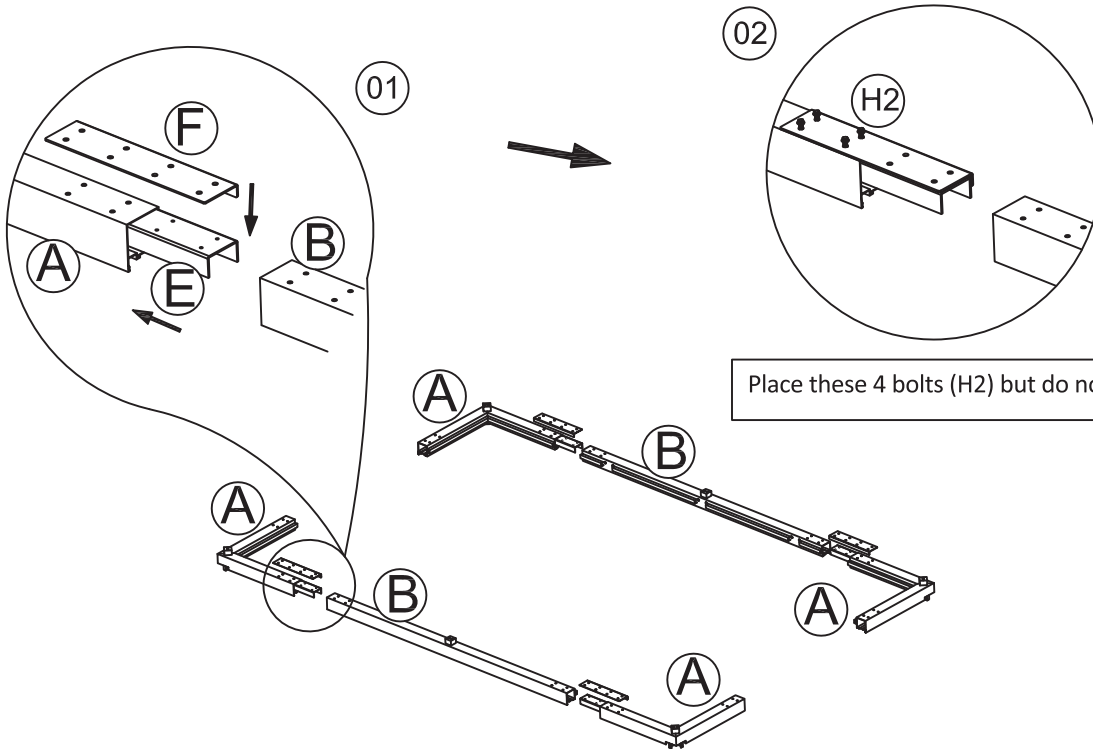
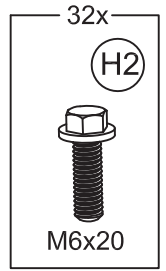
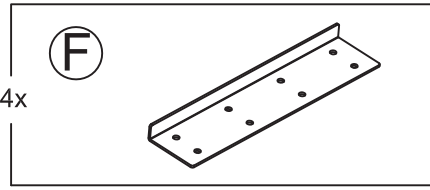
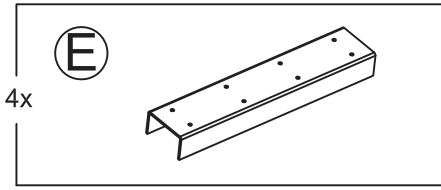

Place these 4 bolts (H2) but do not tighten fully.

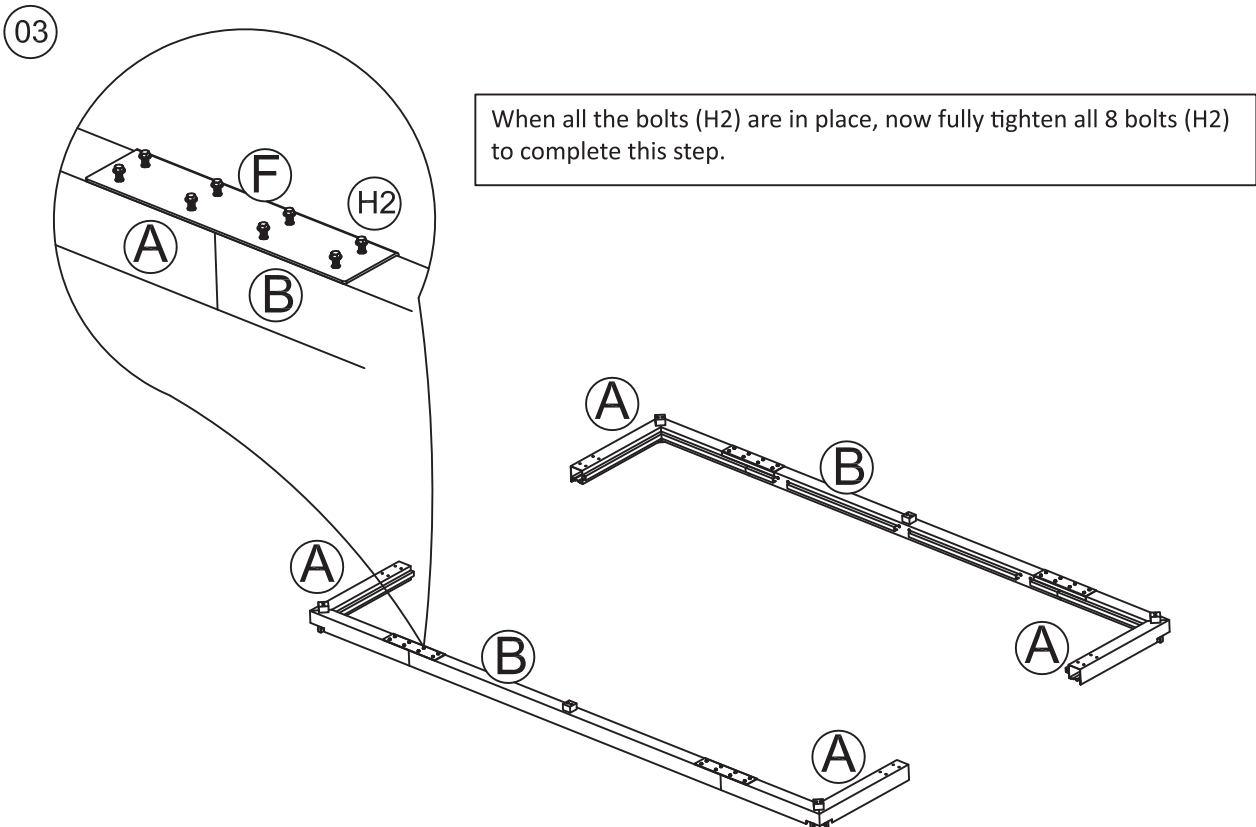

When all the bolts (H2) are in place, now fully tighten all 8 bolts (H2) to complete this step.

5

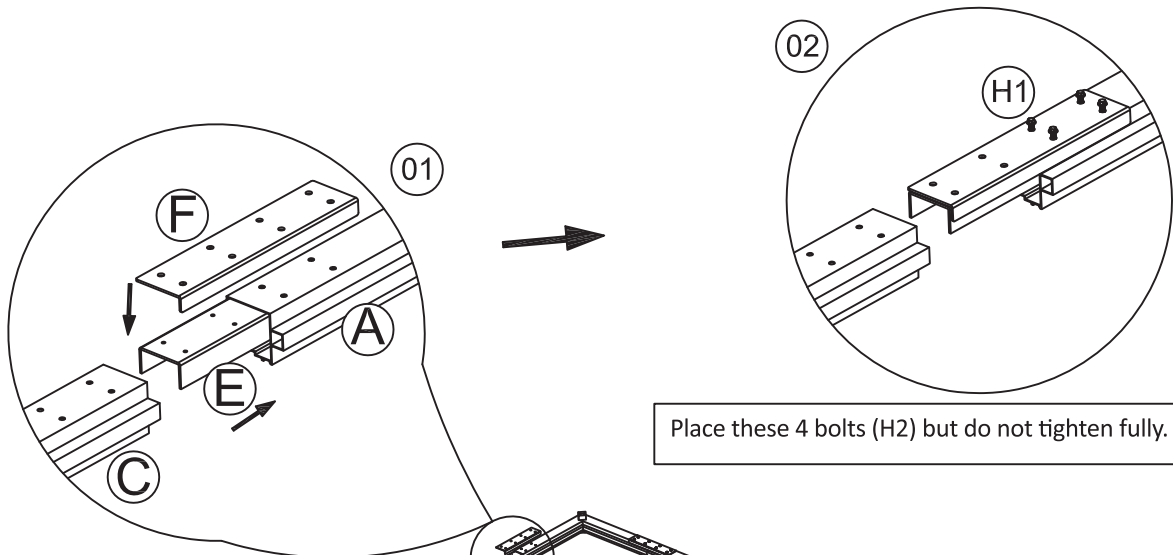
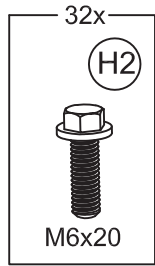
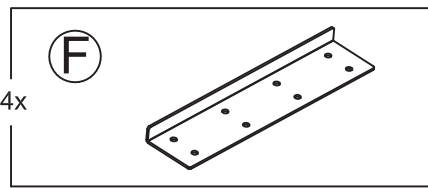
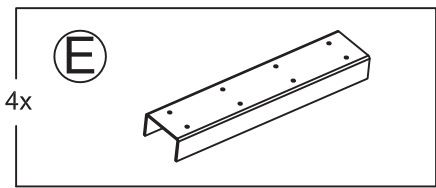

Place these 4 bolts (H2) but do not tighten fully.

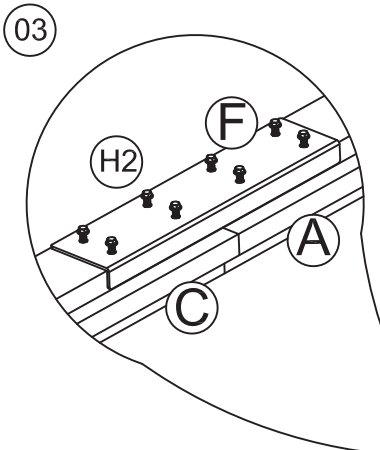
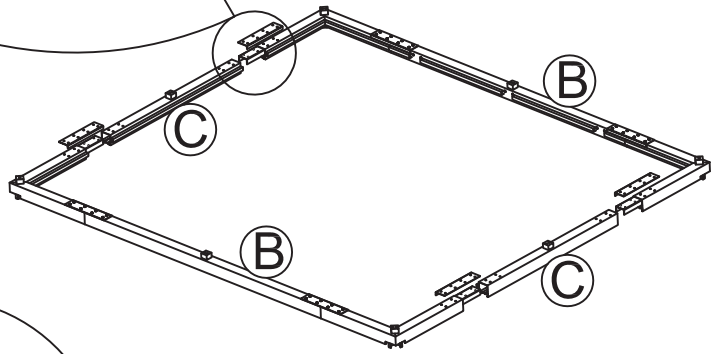

When all the bolts (H2) are in place, now fully tighten all 8 bolts (H2) to complete this step.

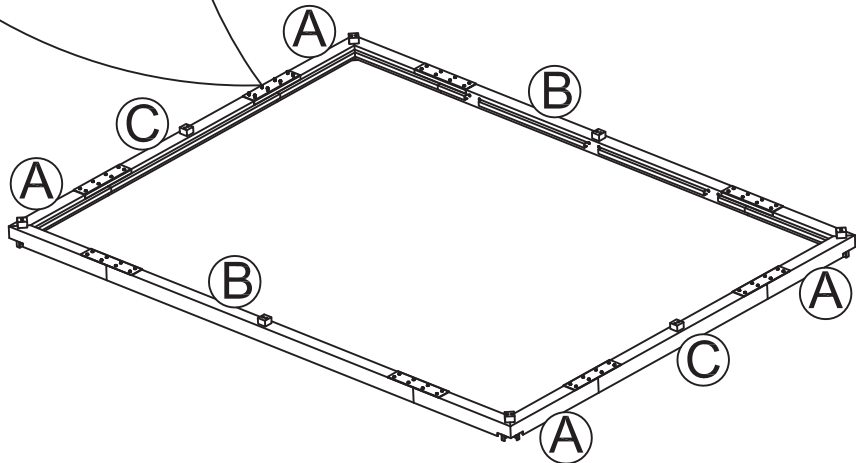

6

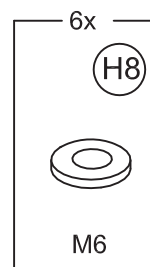
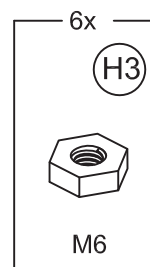
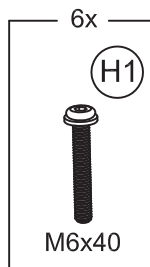
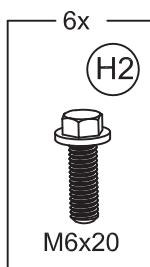
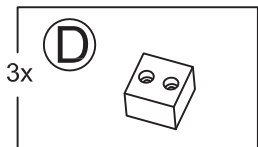
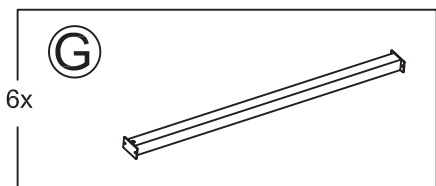

Connect the floor joists (G) as shown. Then install the plastic feet (D). Tighten all the bolts to complete this step.

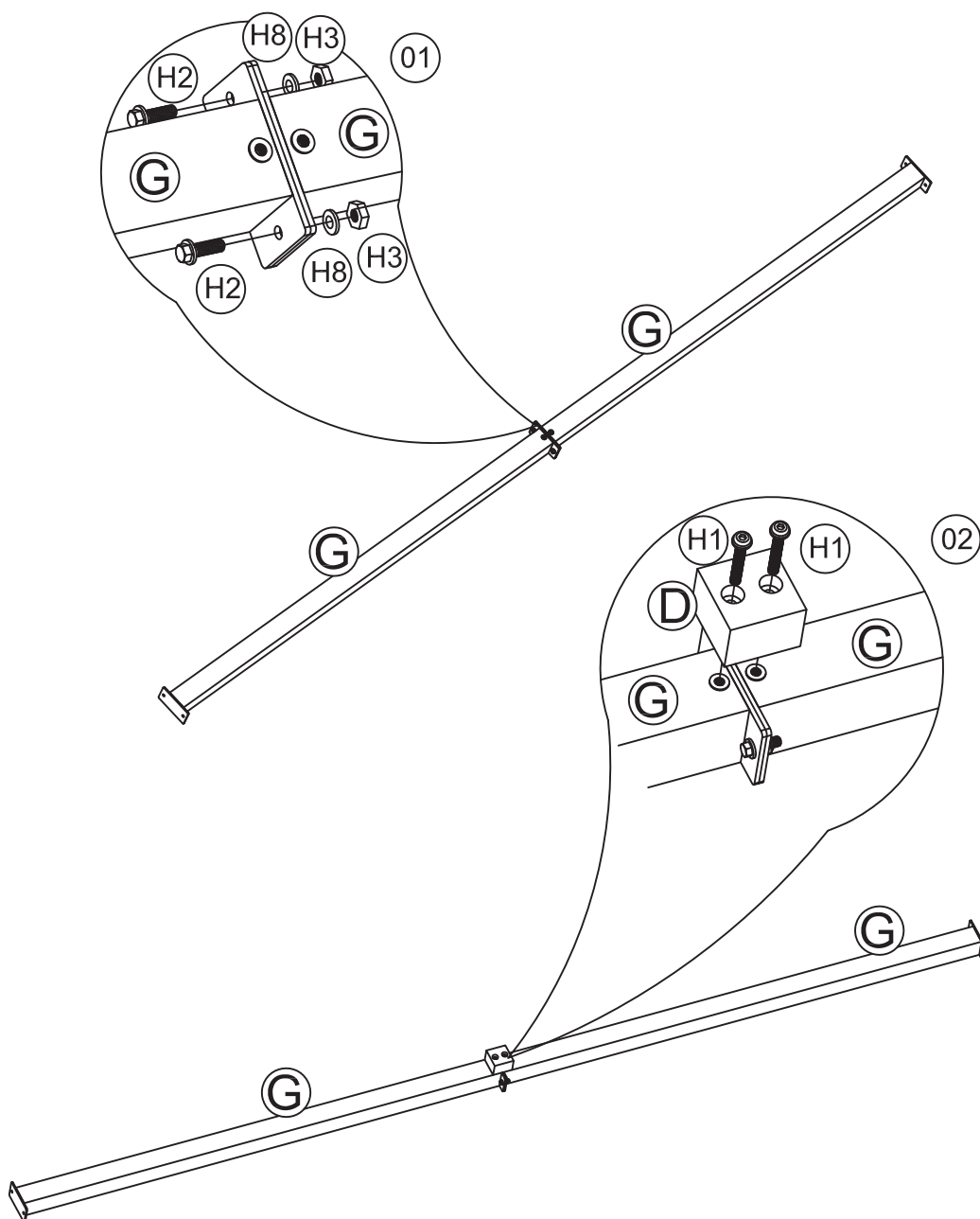

7

Ensure that the floor base with the feet is secured on your prepared surface.

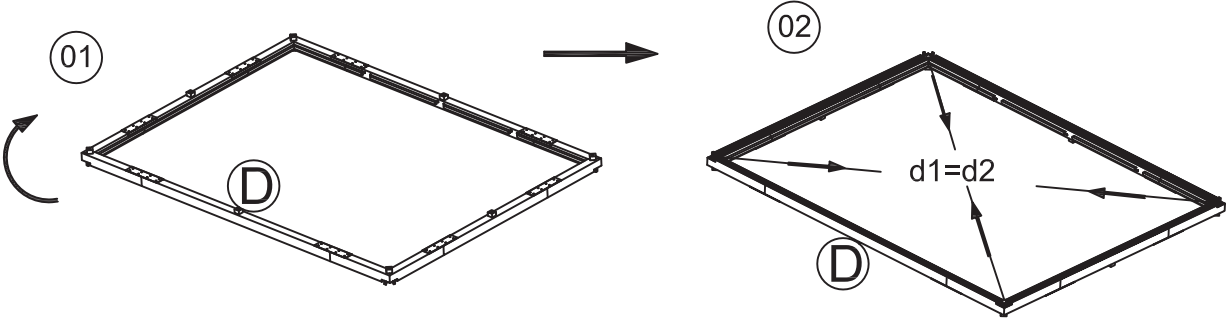
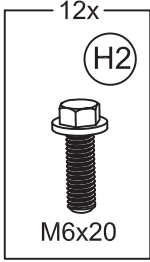

Install the floor joists (G) onto the floor base. Fully tighten these bolts (H2) after this step has been completed.

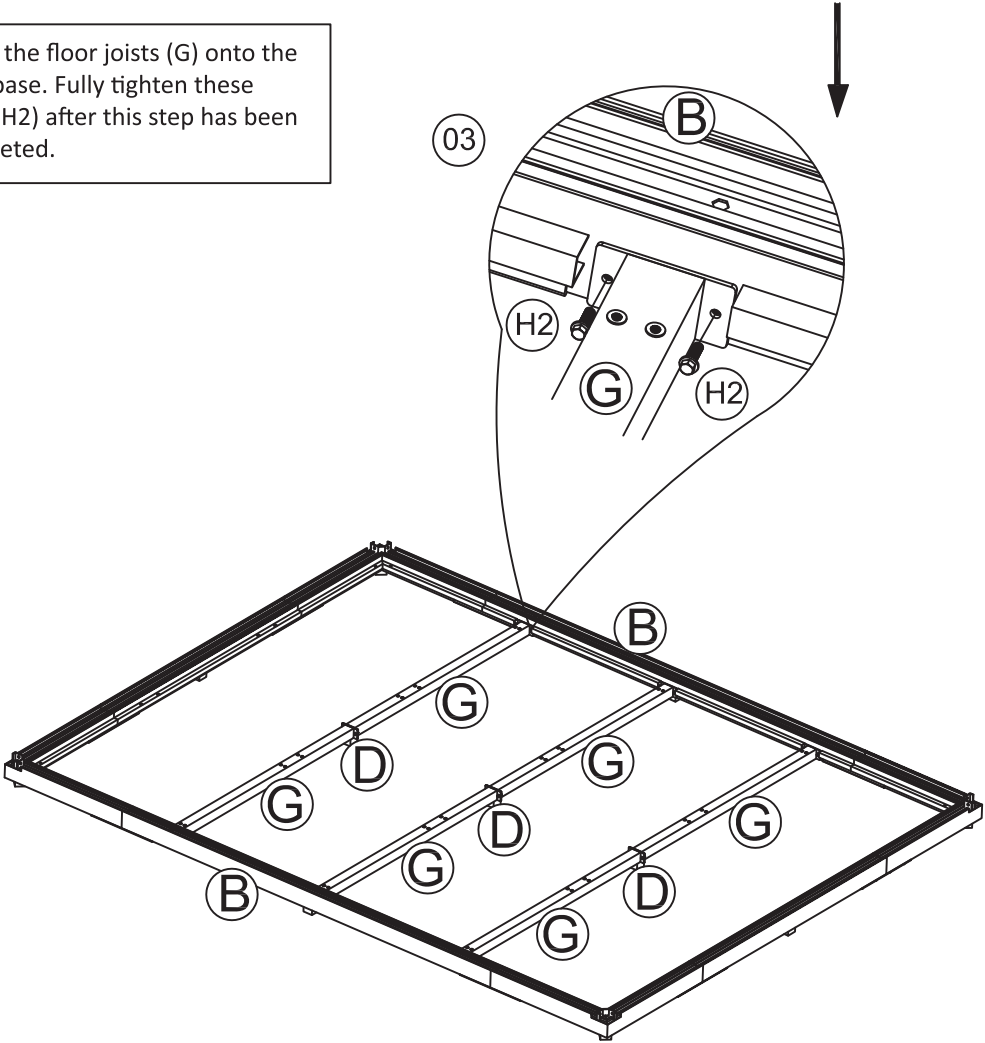

8

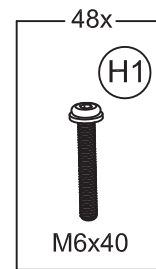
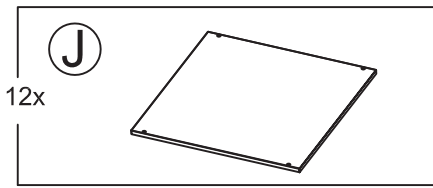

Place all the floor reinforcement boards onto the floor base, place all the bolts (H1) but do not tighten fully. When all these 48 bolts (H1) are in place, now fully tighten all bolts (H1) to complete this step.

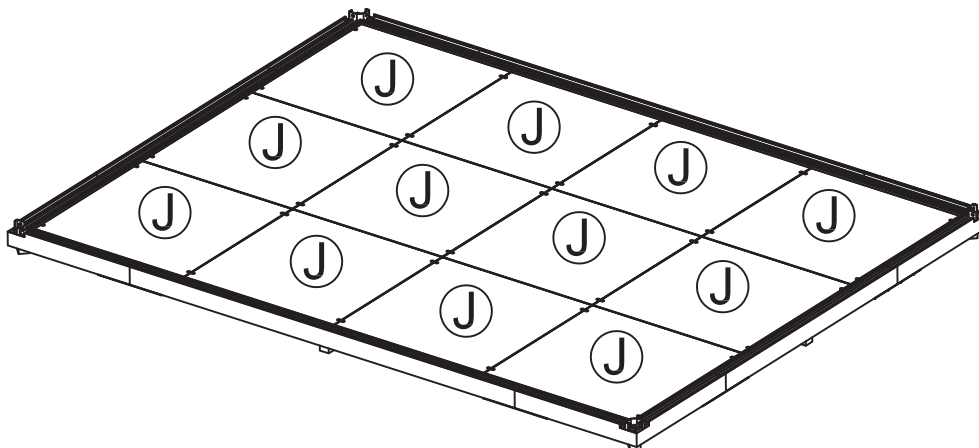
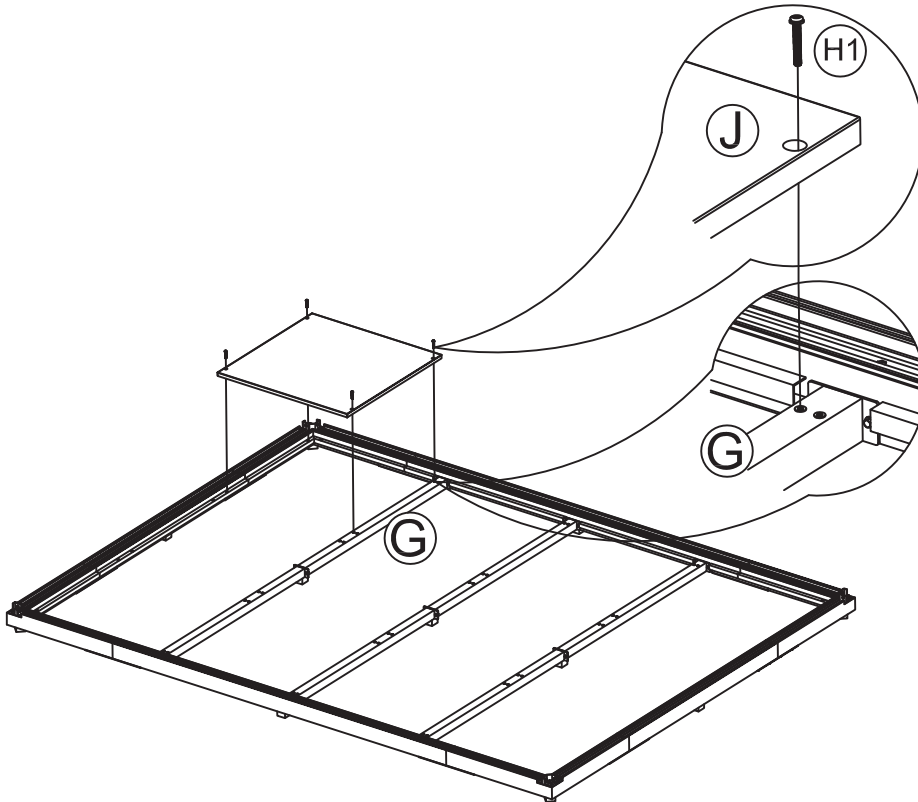

9

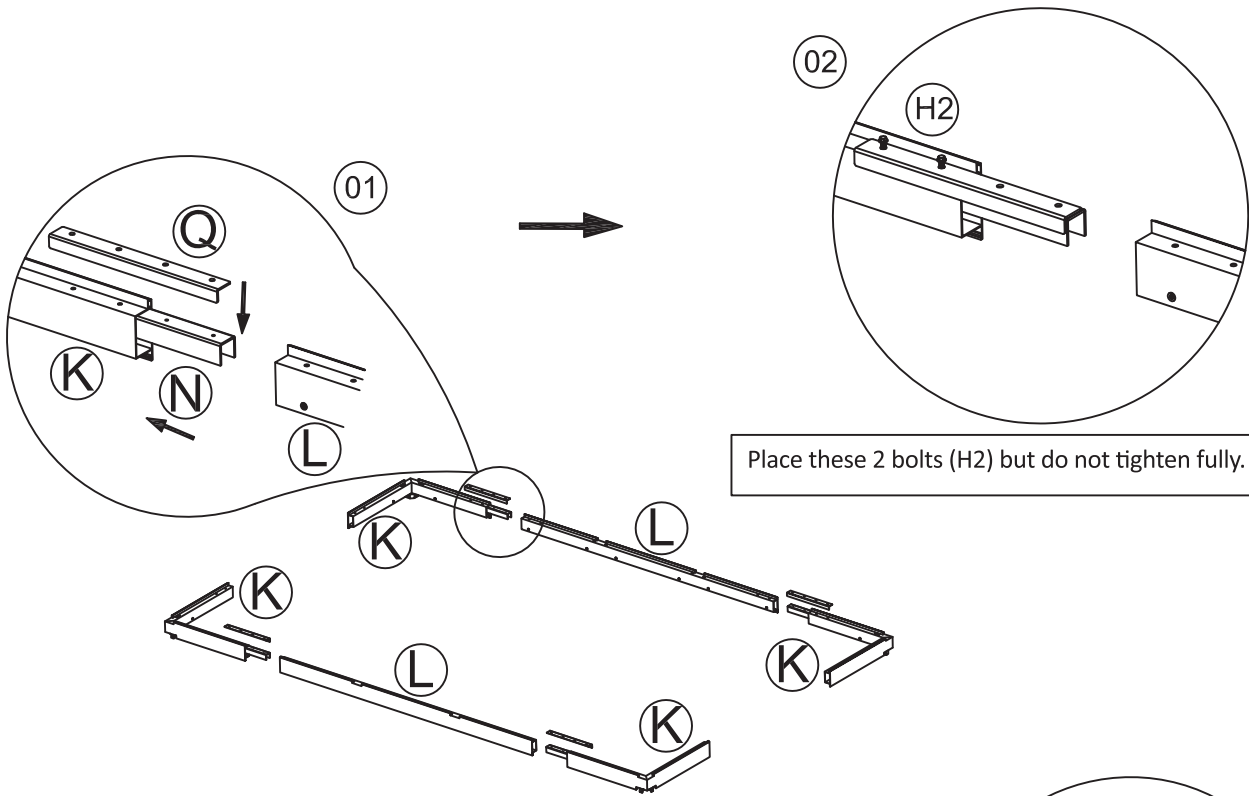
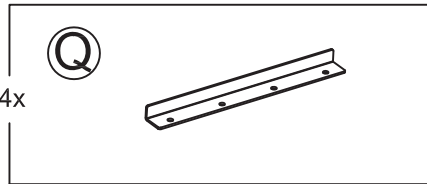
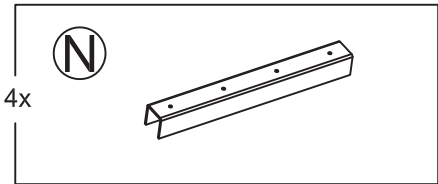
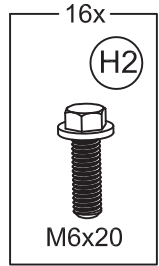
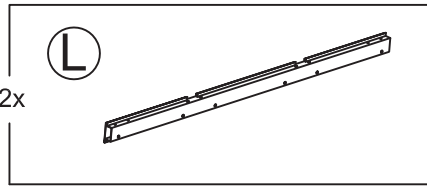
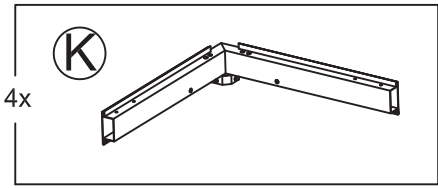

When all the bolts (H2) are in place, now fully tighten all 4 bolts (H2) to complete this step.

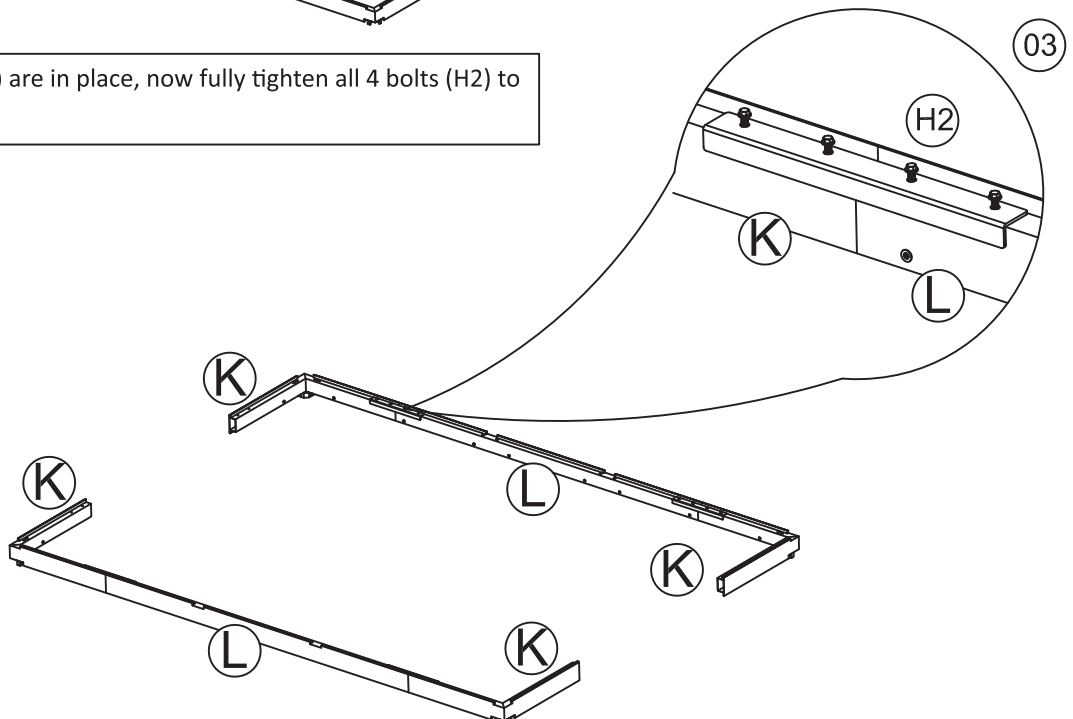

10

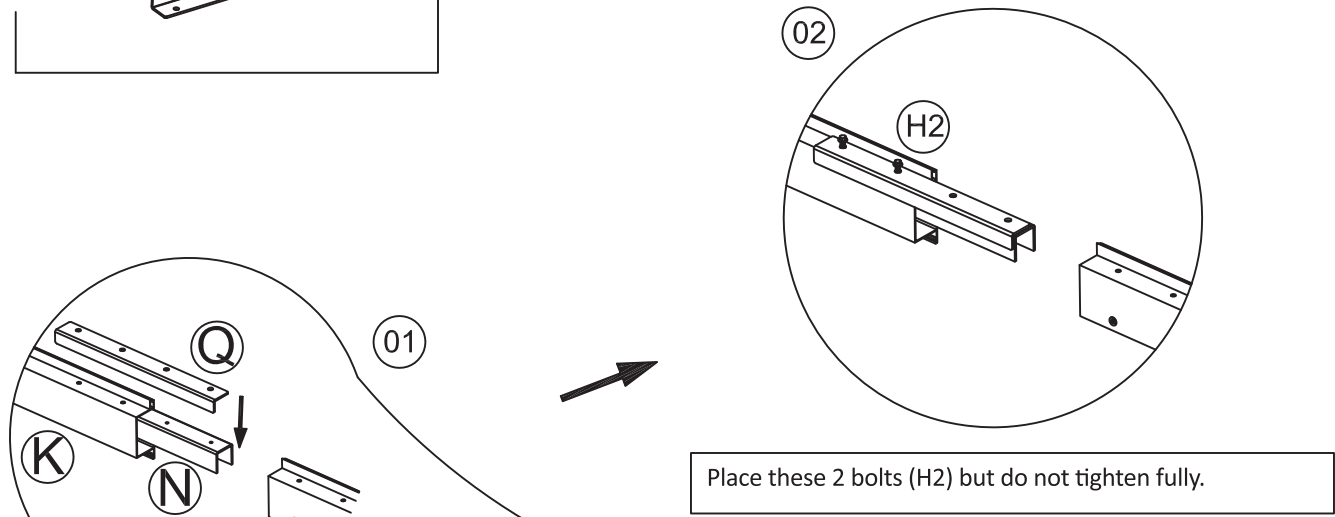
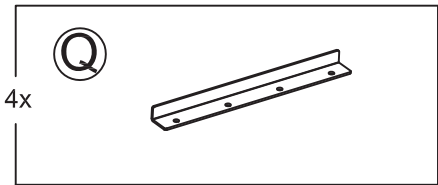
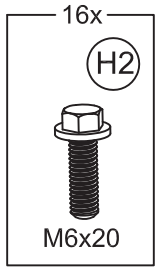
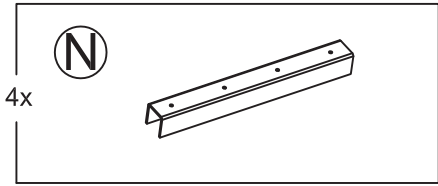
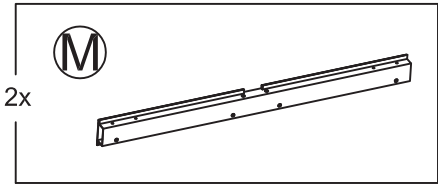

When all the bolts (H2) are in place, now fully tighten all 4 bolts (H2) to complete this step.

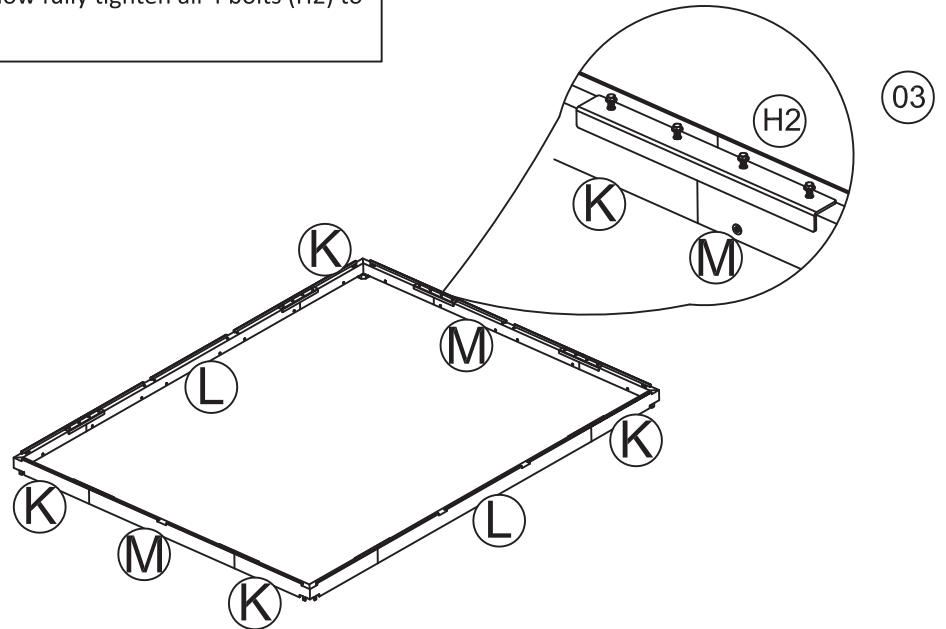

11

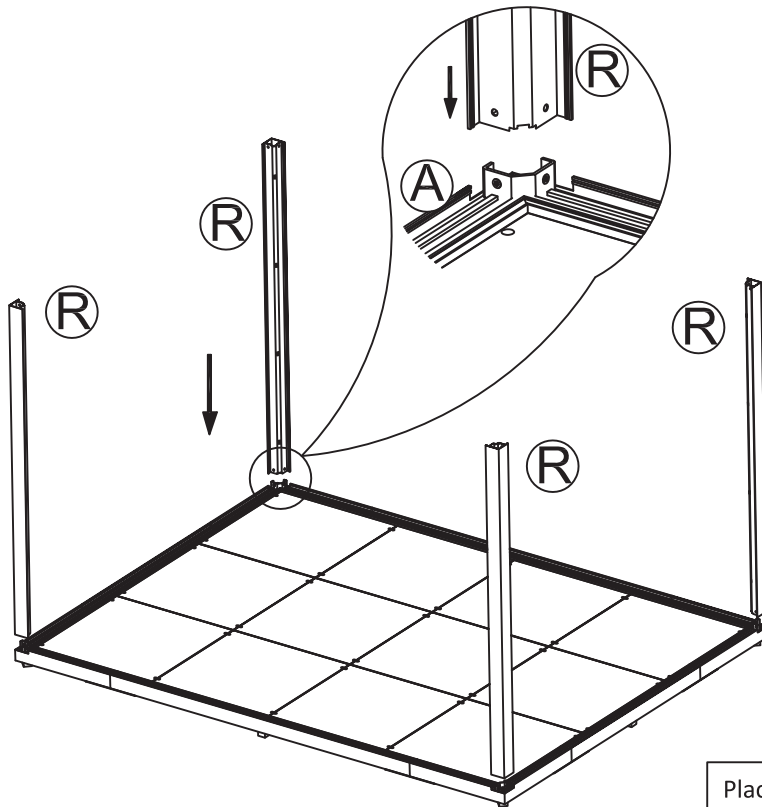
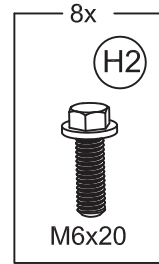
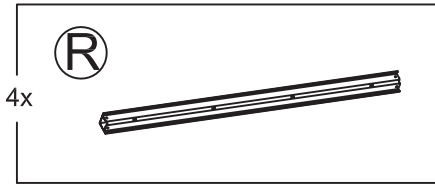

Place these 2 bolts (H2) but do not tighten fully.

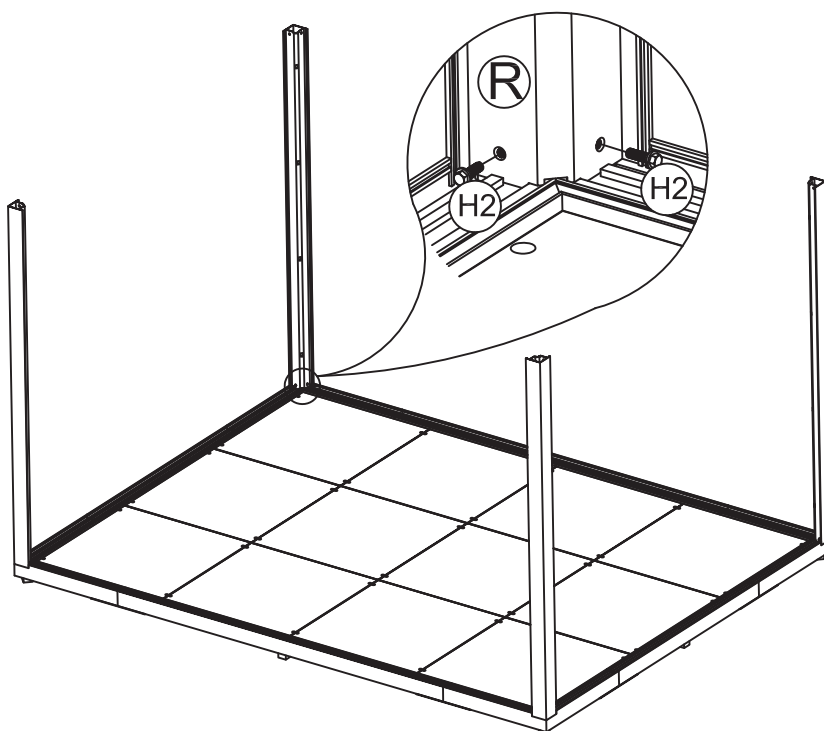

13

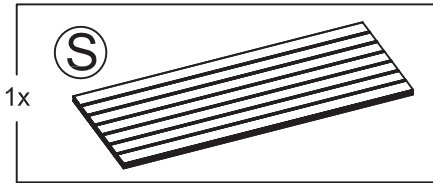

MODULAR WALL SYSTEM

Wall and window panels are modular and interchangeable, allowing them to be installed in different positions around the perimeter, offering flexibility and customization.

Carefully consider the orientation on your property, the views and light, and desired TV position when planning the wall placement.

Make sure you have thoughtfully considered and planned out your wall and window positions before you start to assemble.

Leave 0.4 in / 10mm clearance between corner posts (R) and walls (S) to allow the gap filler (U) to fit in later.

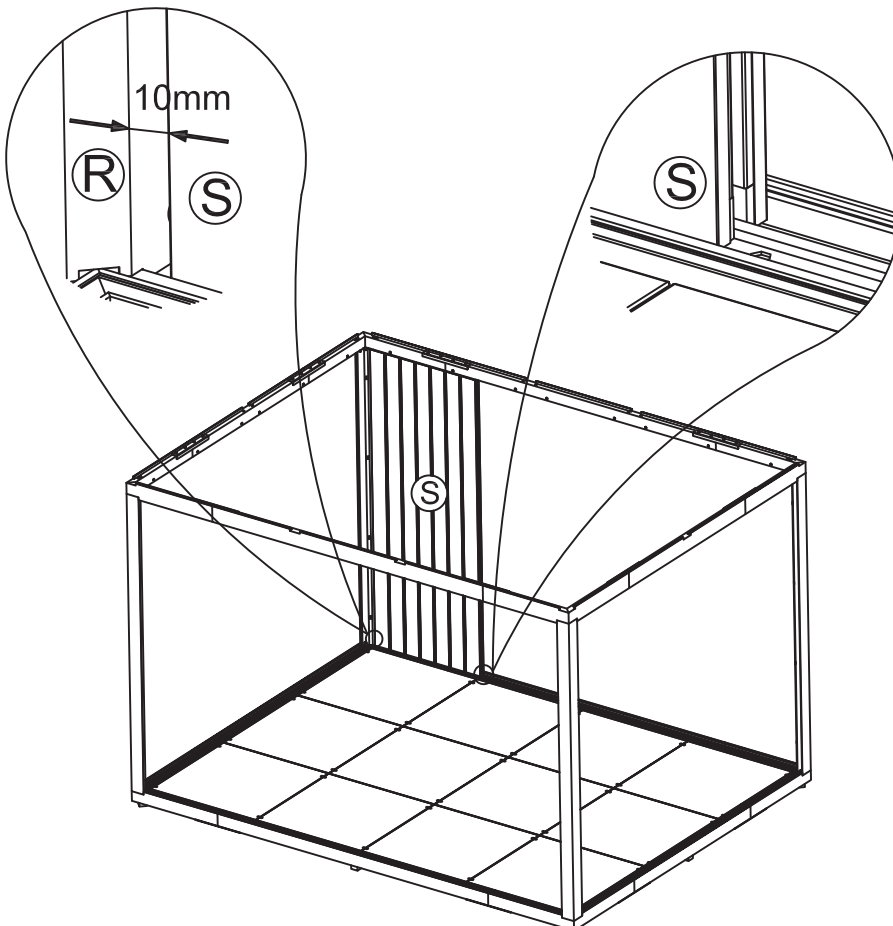

Attention: Assemble the walls from inside of the shed.

14

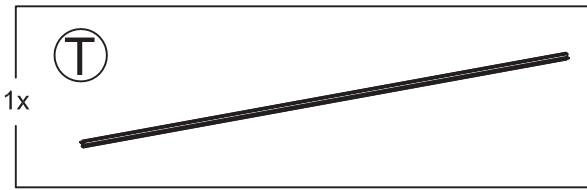

Place the wall connector (T) against the edge of the wall (S).

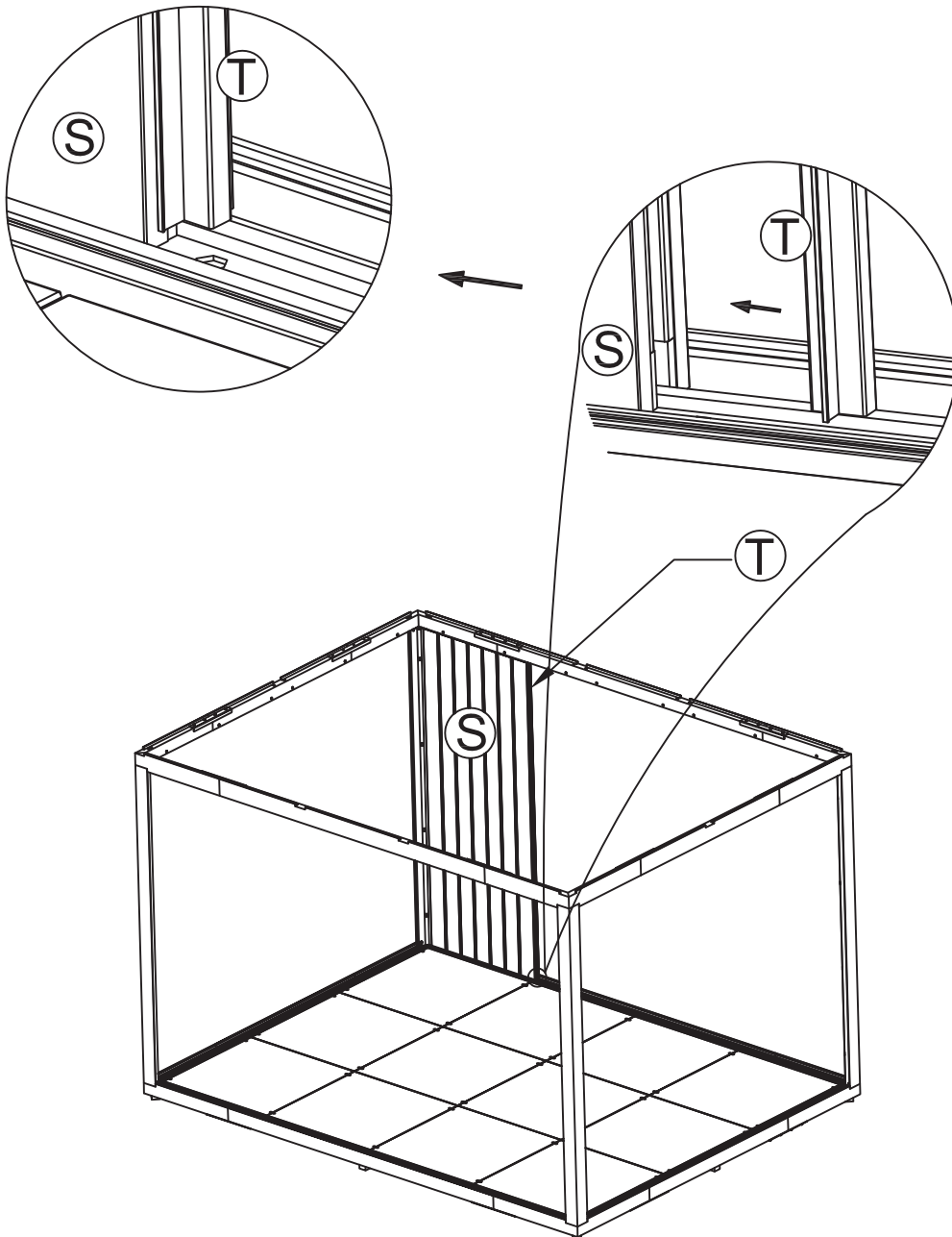

15

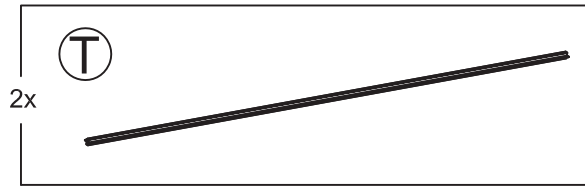
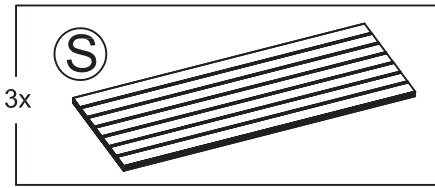

A wall connector (T) must be installed between every 2 walls (S).

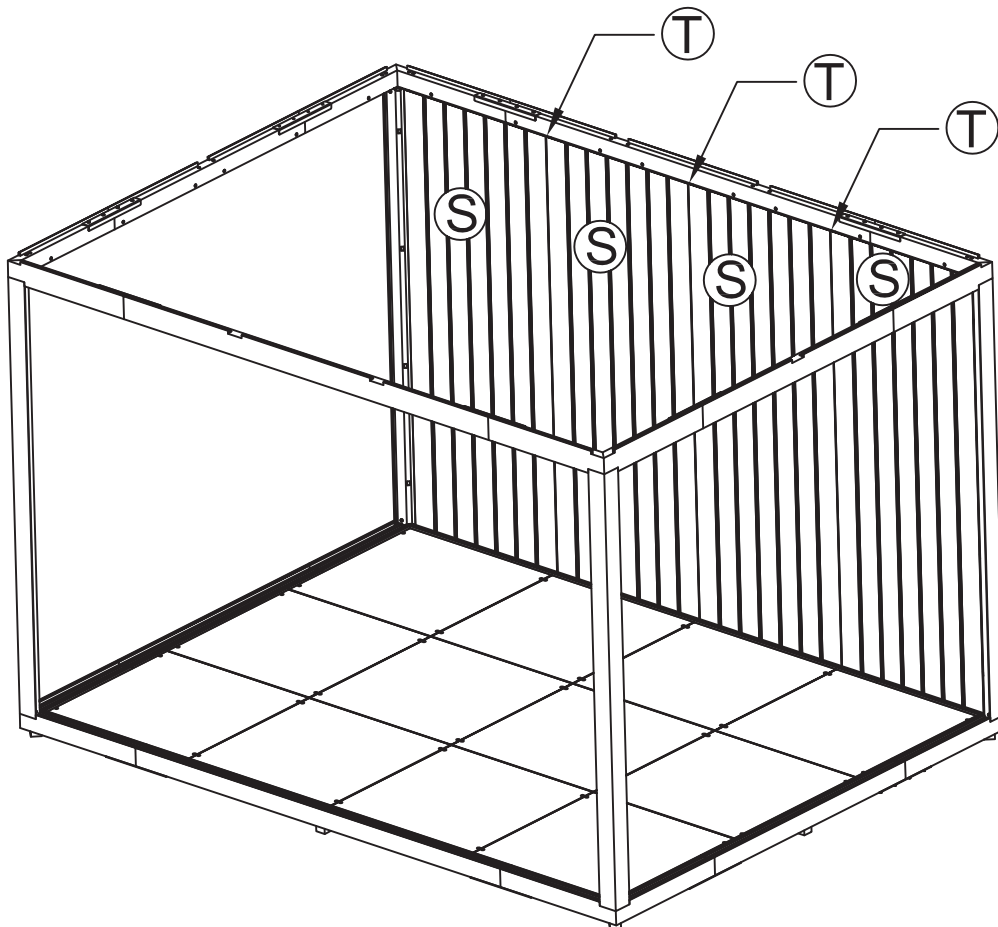

16

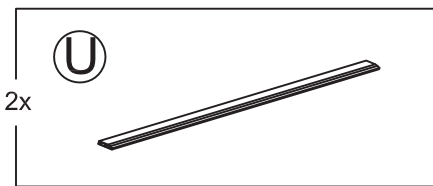

Insert the gap filler (U) with the bevel facing in and carefully tap in with a rubber hammer.

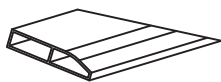

It is recommended to place the gap filler (U) in the middle.

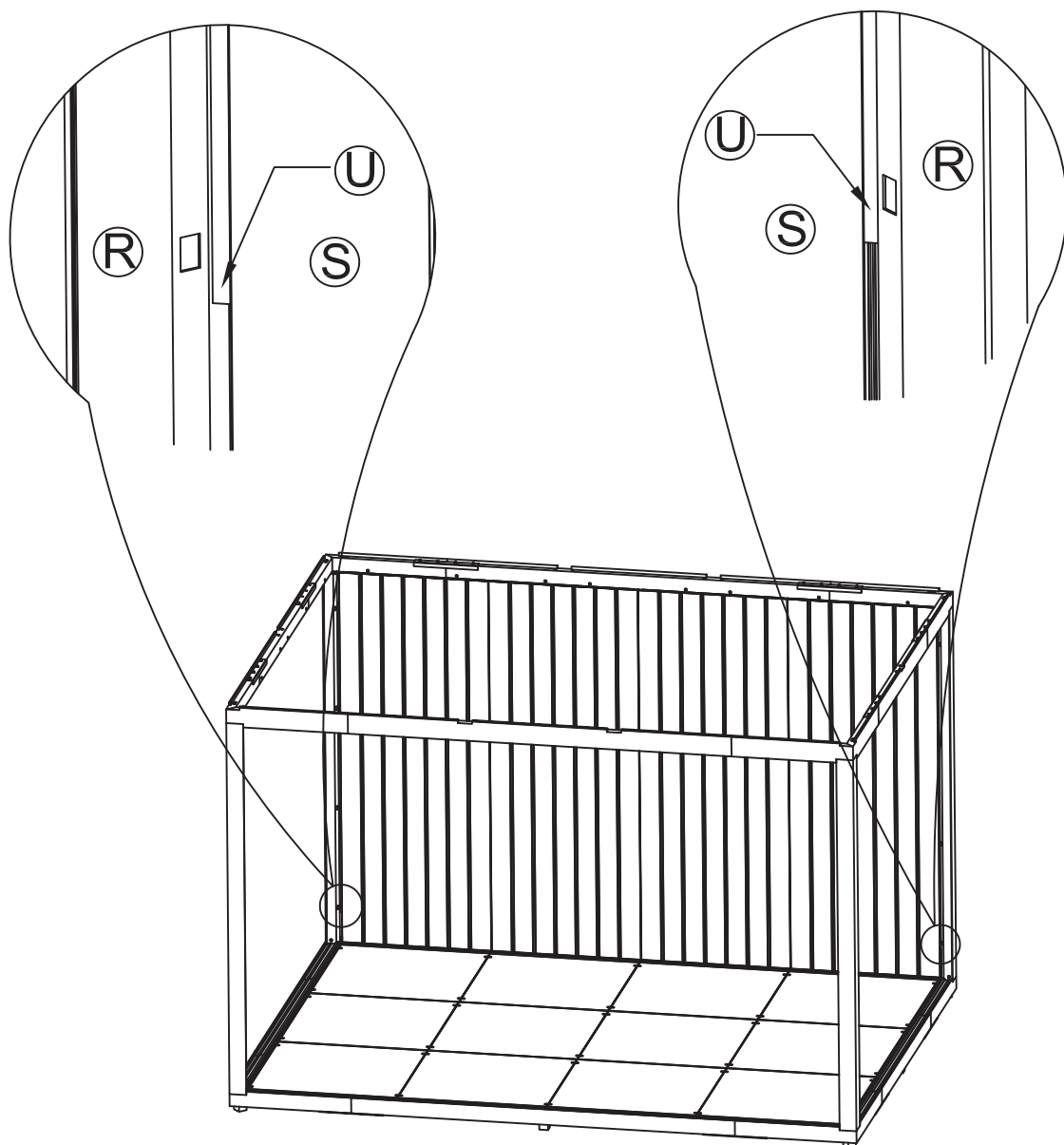

17

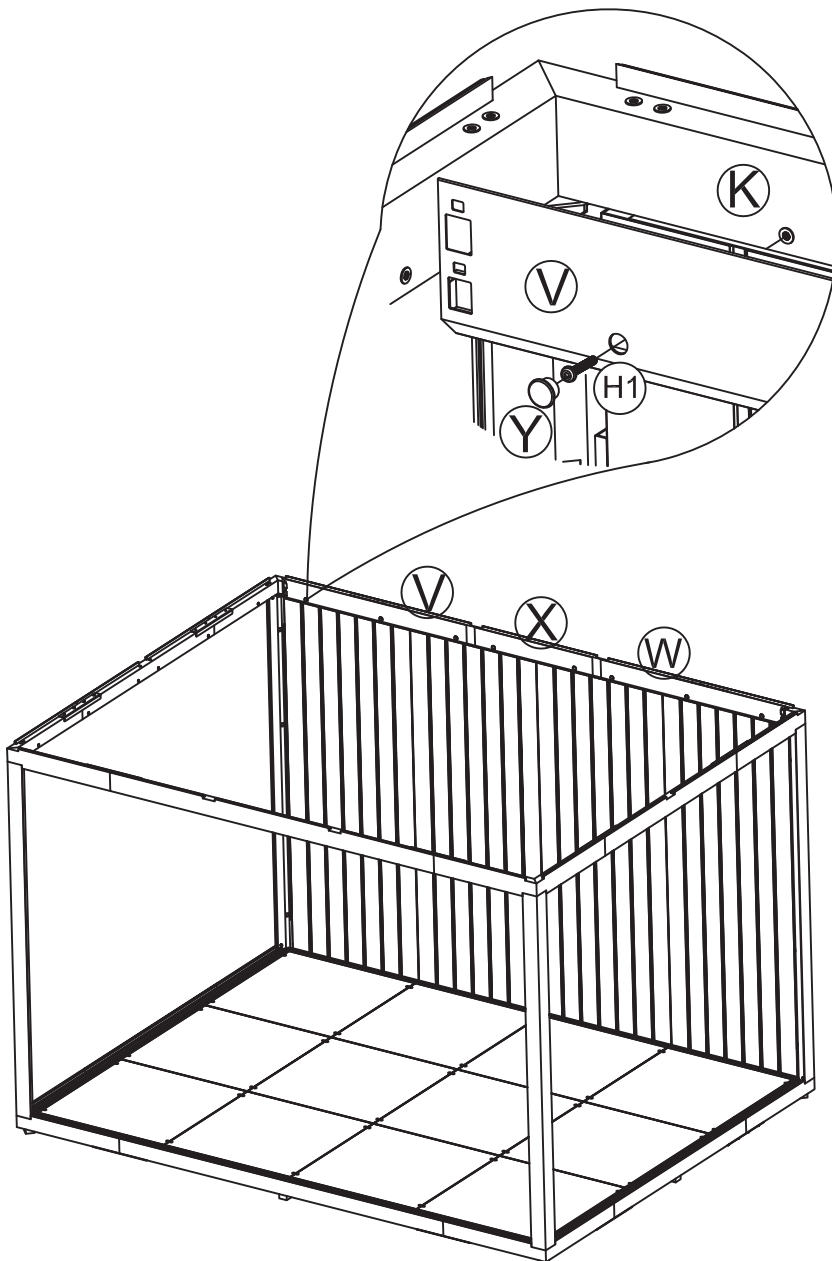
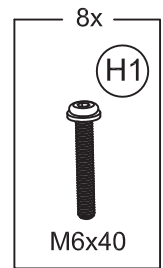
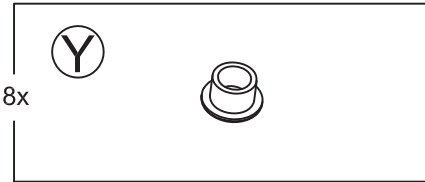
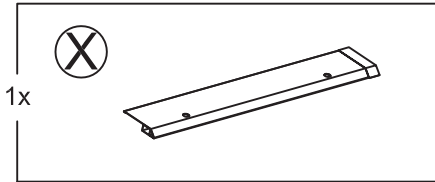
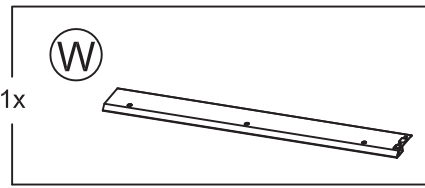
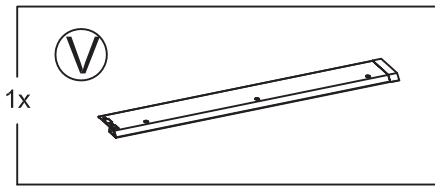

Insert all the bolts into the mounting holes but do not fully tighten. After ensuring all the parts are in the correct position, then finally tighten all the bolts to complete this step.

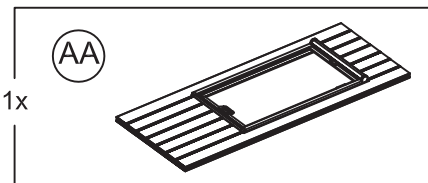
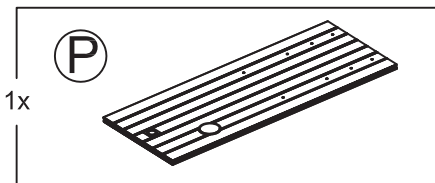
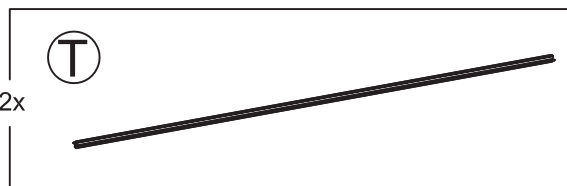
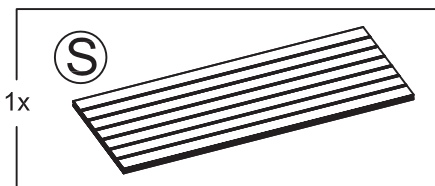

Leave 0.4 in / 10mm clearance between corner posts (R) and walls (S) to allow the gap filler (U) to fit in later.

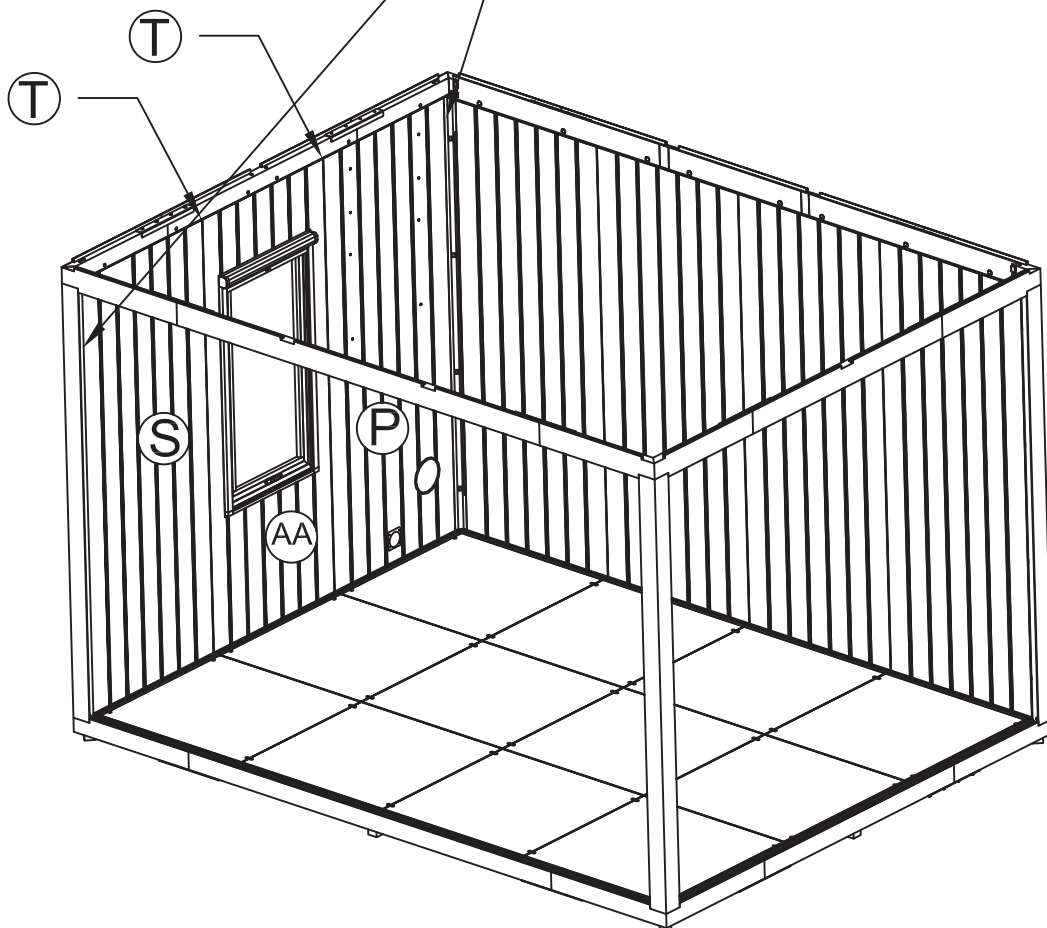

19

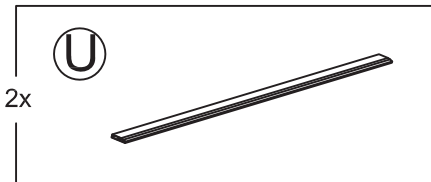

Insert the gap filler (U) with the bevel facing in and carefully tap in with a rubber hammer.

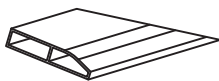

It is recommended to place the gap filler (U) in the middle.

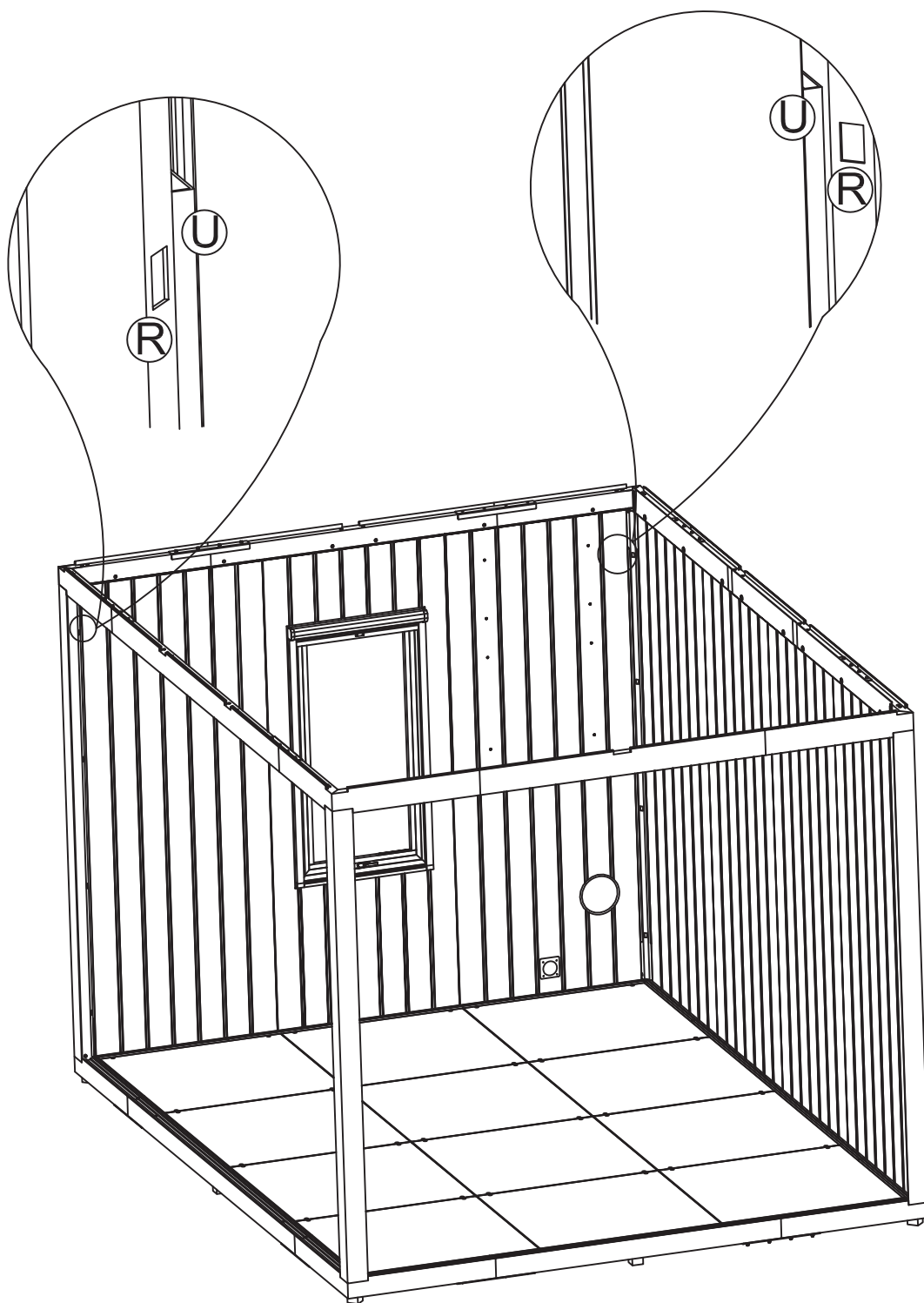

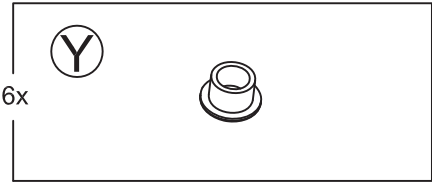
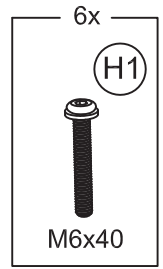
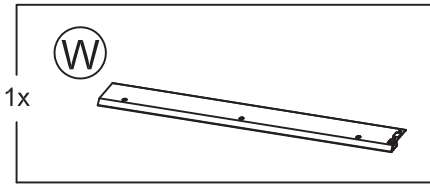
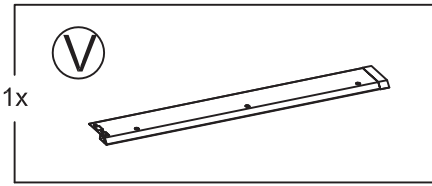

Insert all the bolts into the mounting holes but do not fully tighten. After ensuring all the parts are in the correct position, then finally tighten all the bolts to complete this step.

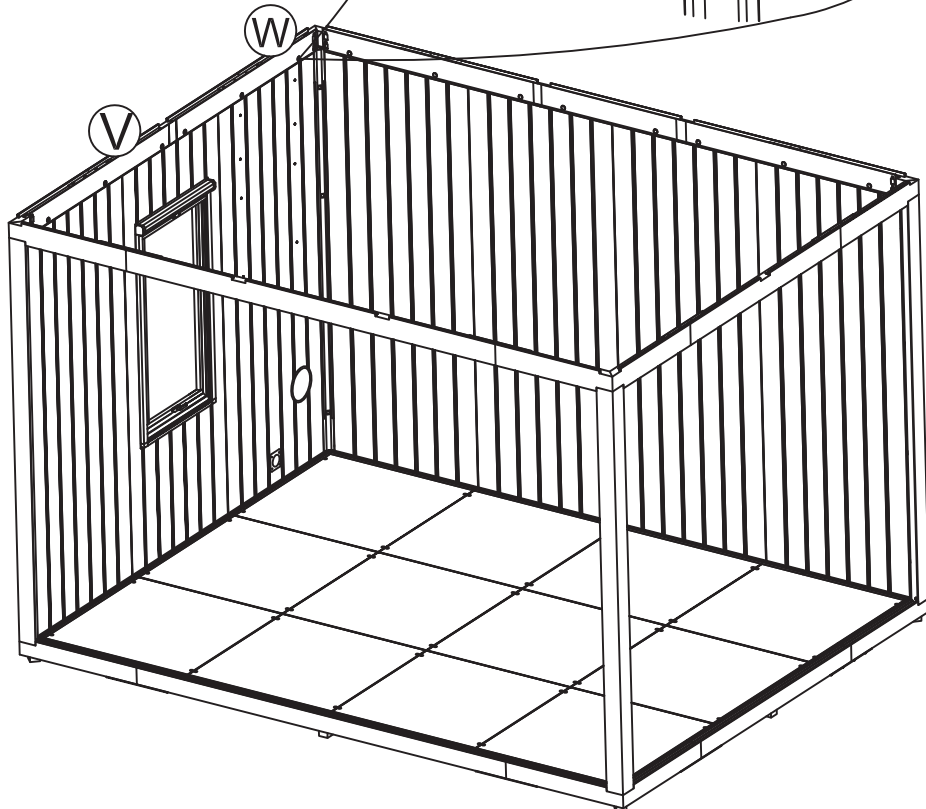
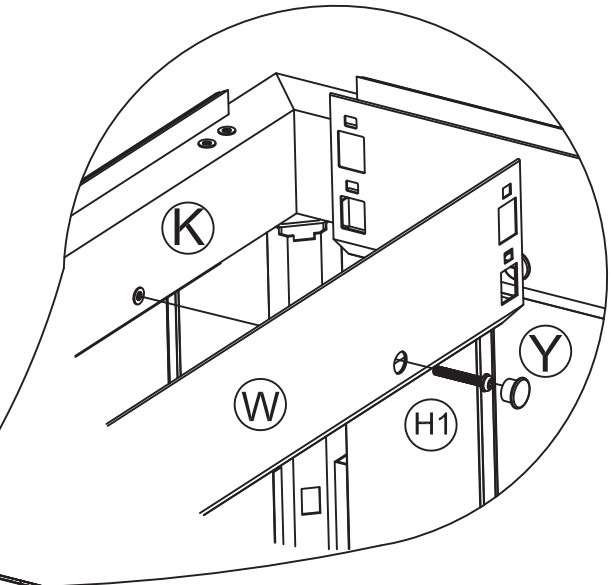

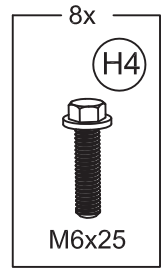
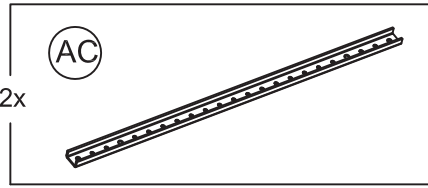
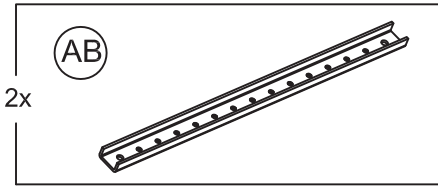

Only mount a TV on the predrilled wall panel (P).
Recommended TV Size is 101.6 cm / 40 in and
the maximum weight for the TV bracket is: 40 kg
/ 88 lb.

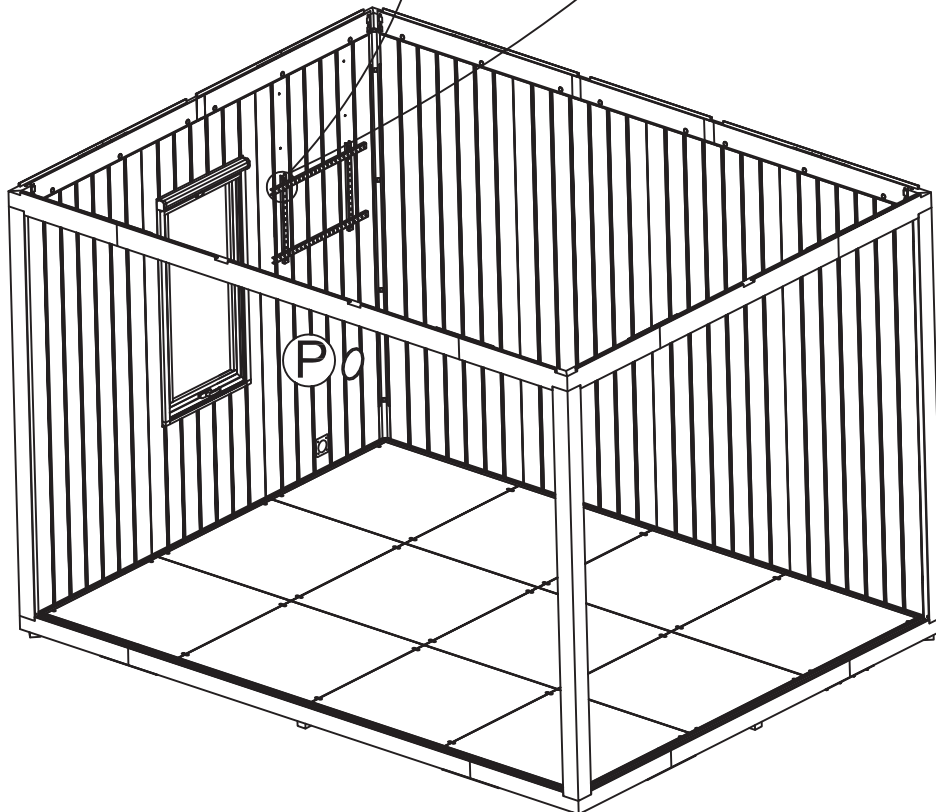
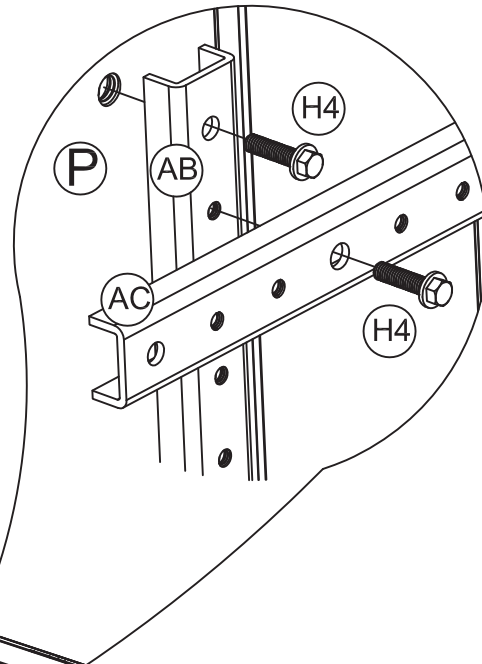

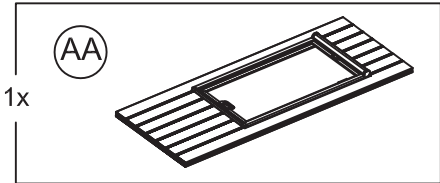
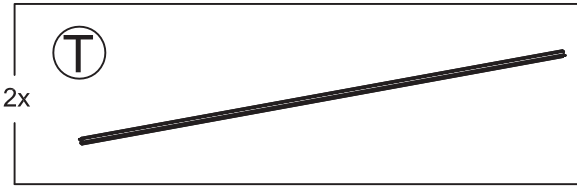
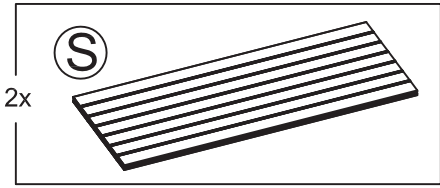

Leave 0.4 in / 10mm clearance between corner posts (R) and walls (S) to allow the gap filler (U) to fit in later.

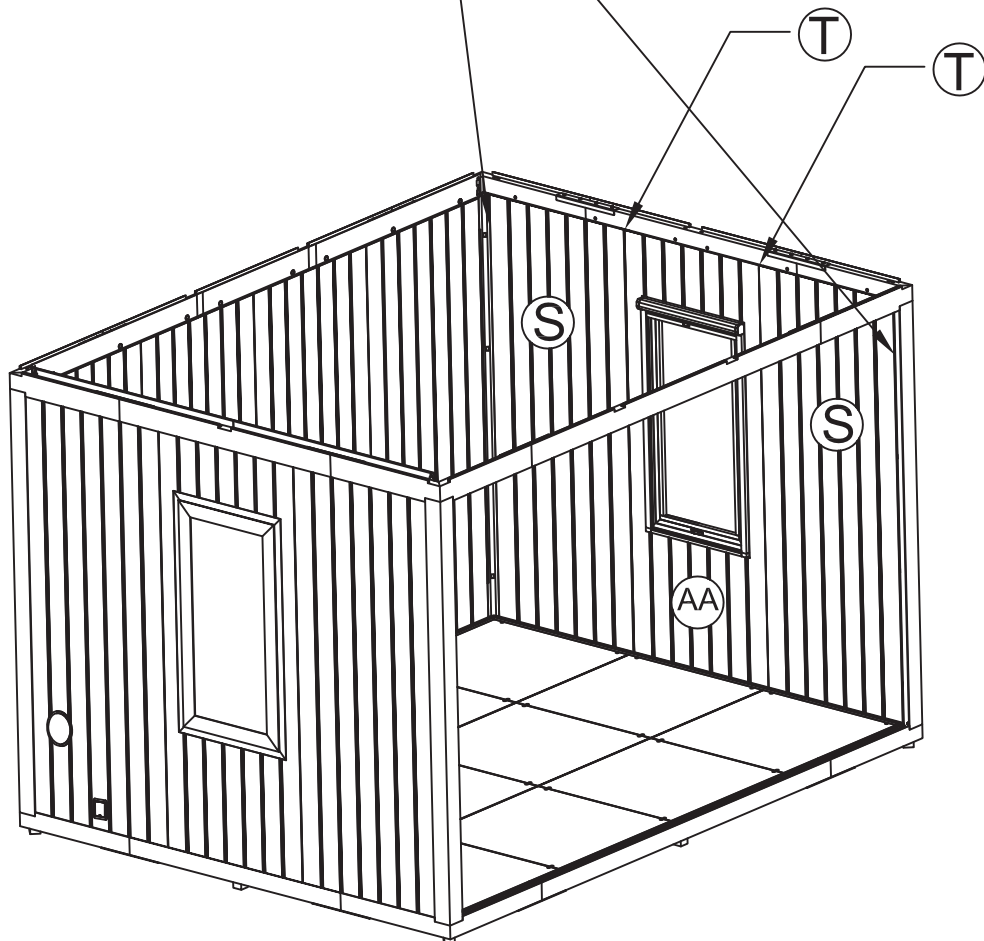

23

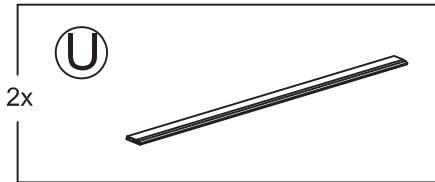

Insert the gap filler (U) with the bevel facing in and carefully tap in with a rubber hammer.

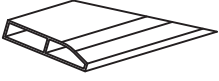

It is recommended to place the gap filler (U) in the middle.

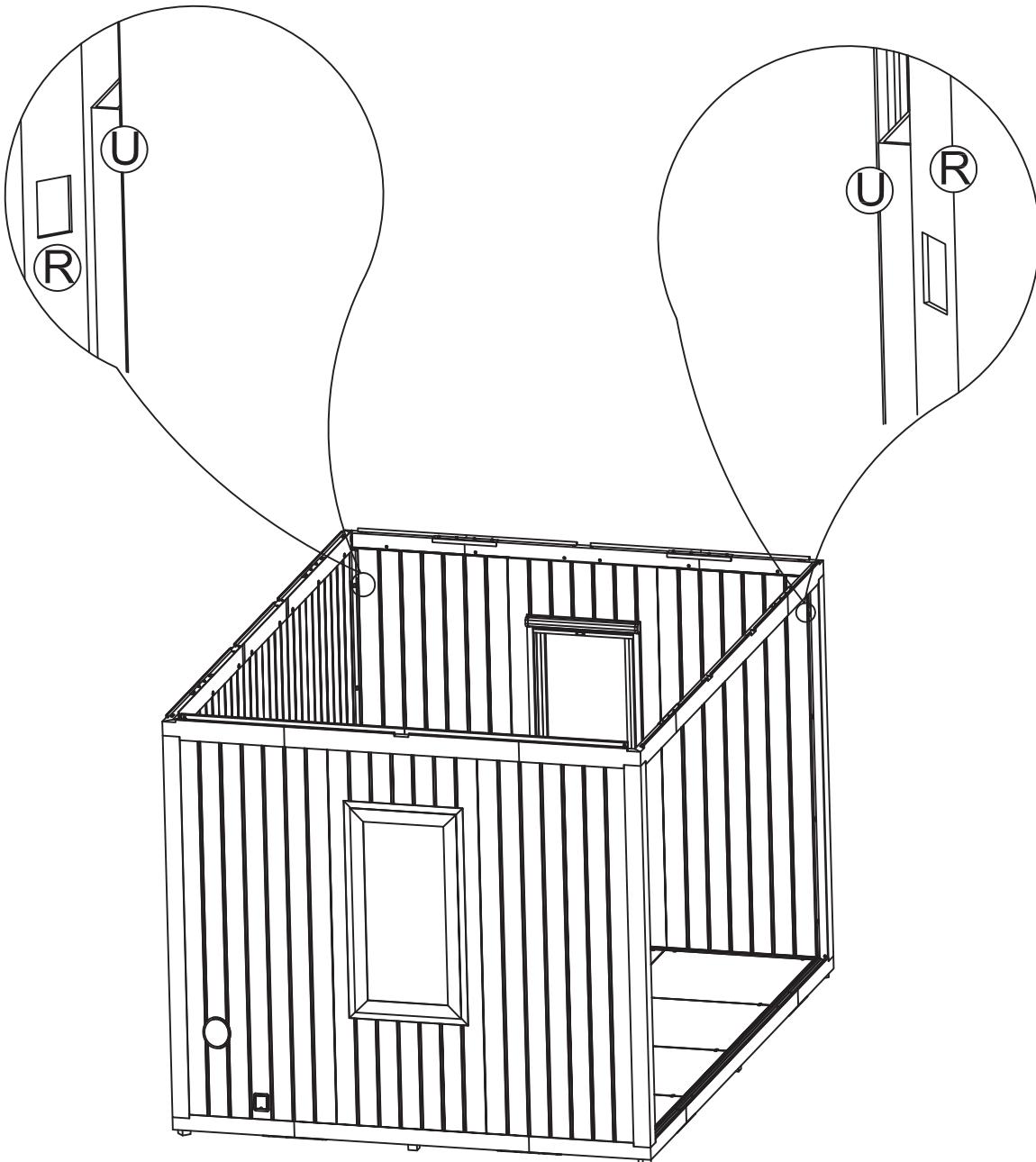

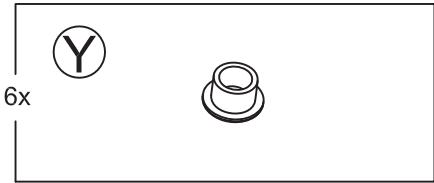
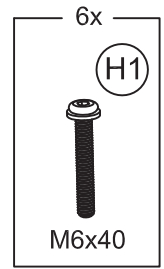
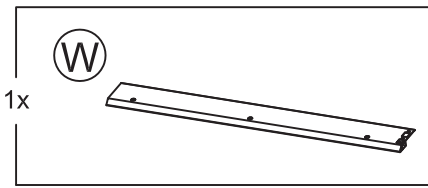
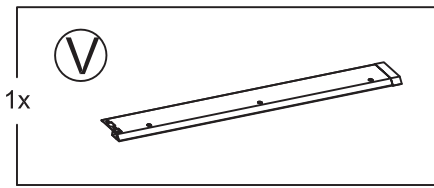

Insert all the bolts into the mounting holes but do not fully tighten. After ensuring all the parts are in the correct position, then finally tighten all the bolts to complete this step.

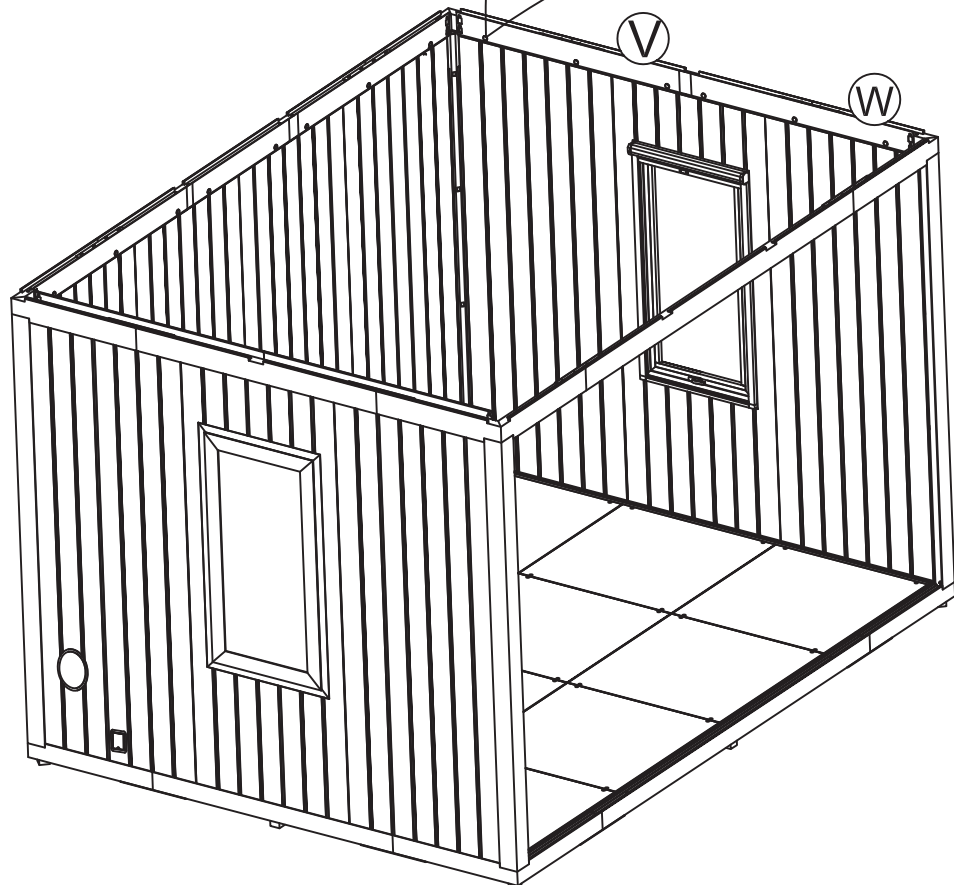
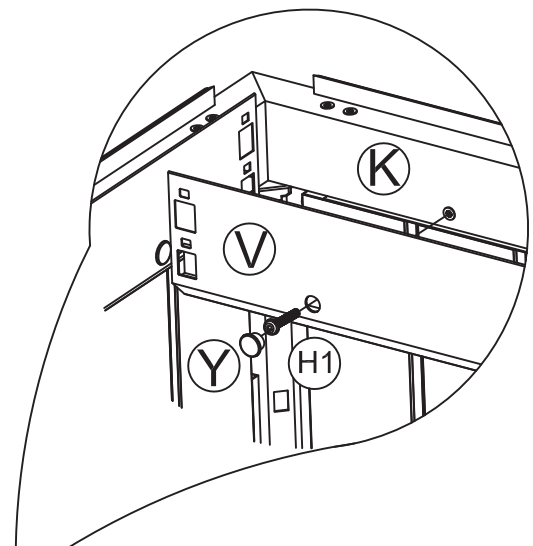

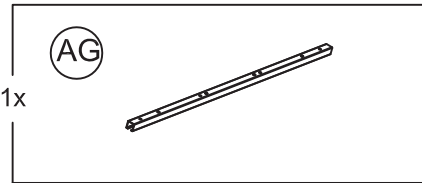
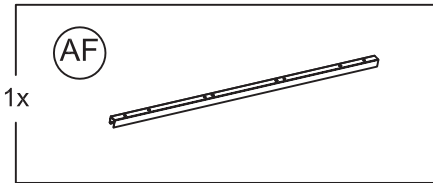
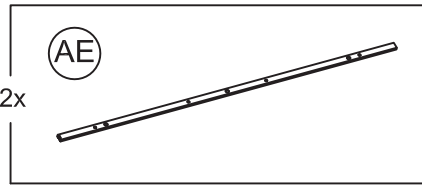
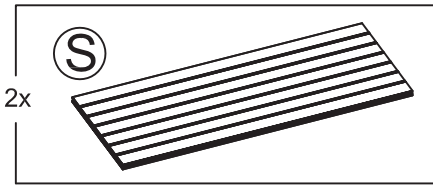

Assemble with flap facing inward.

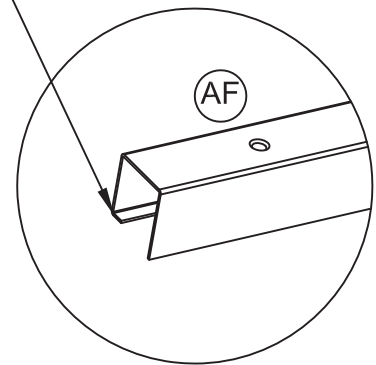

Leave 0.4 in / 10mm clearance between corner posts (R) and walls (S) to allow the gap filler (U) to fit in later.

Place 2 walls (S) in their positions first, then place the door bottom support (AF) with the flap facing inward and the door side supports (AE) against the wall edges (S). Place the door top support (AG) against the top frame. Three people are required to hold AG and (2) AE in place until they are secured.

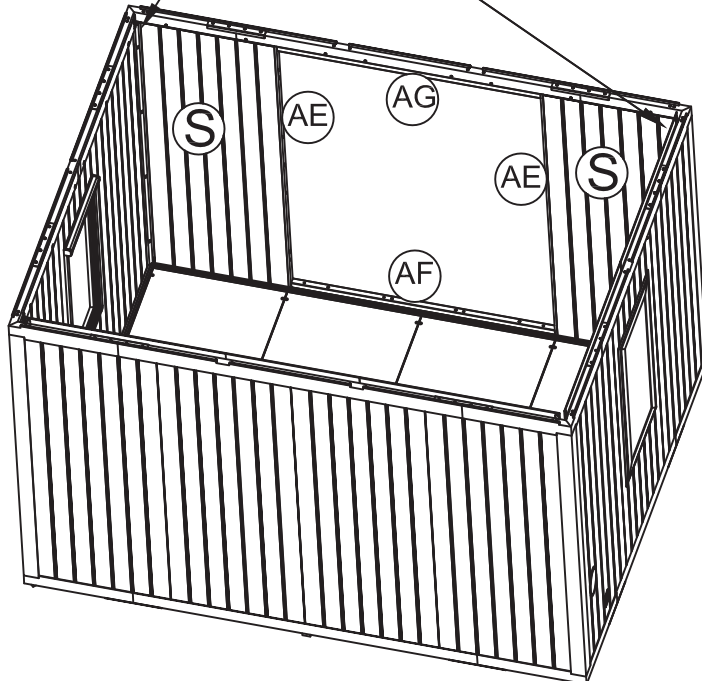

26

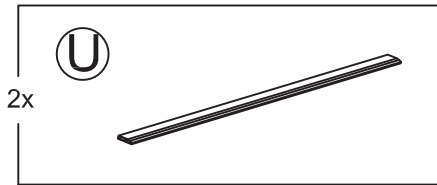

Insert the gap filler (U) with the bevel facing in and carefully tap in with a rubber hammer.

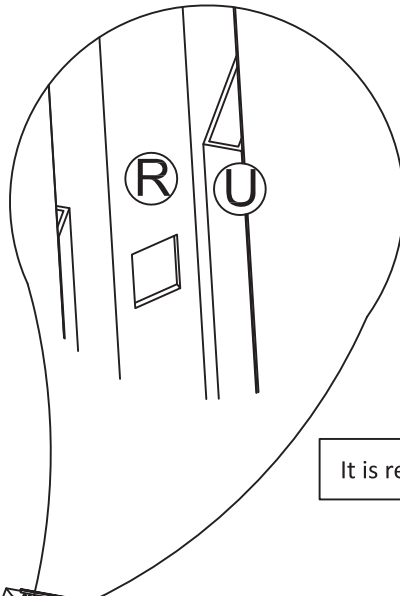
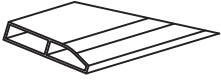

It is recommended to place the gap filler (U) in the middle.

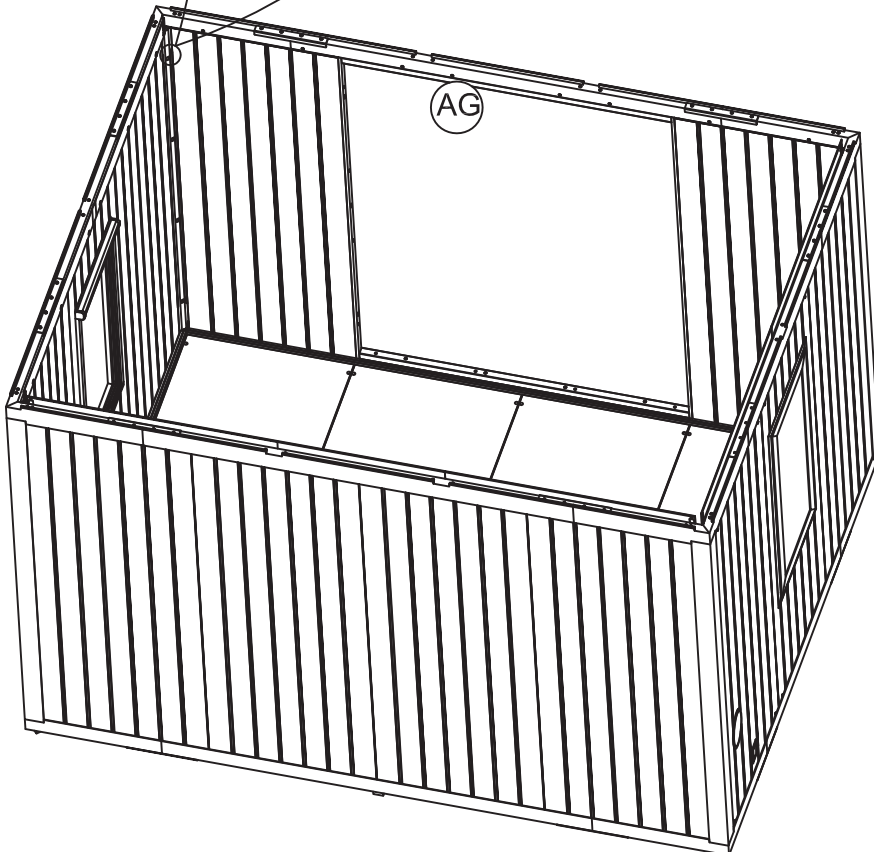

Secure the door top support (AG) using 4 bolts.

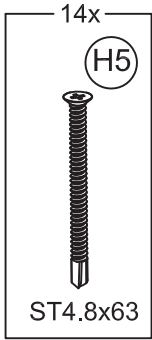

Secure the (2) door side supports (AE) using 3 bolts for each side.

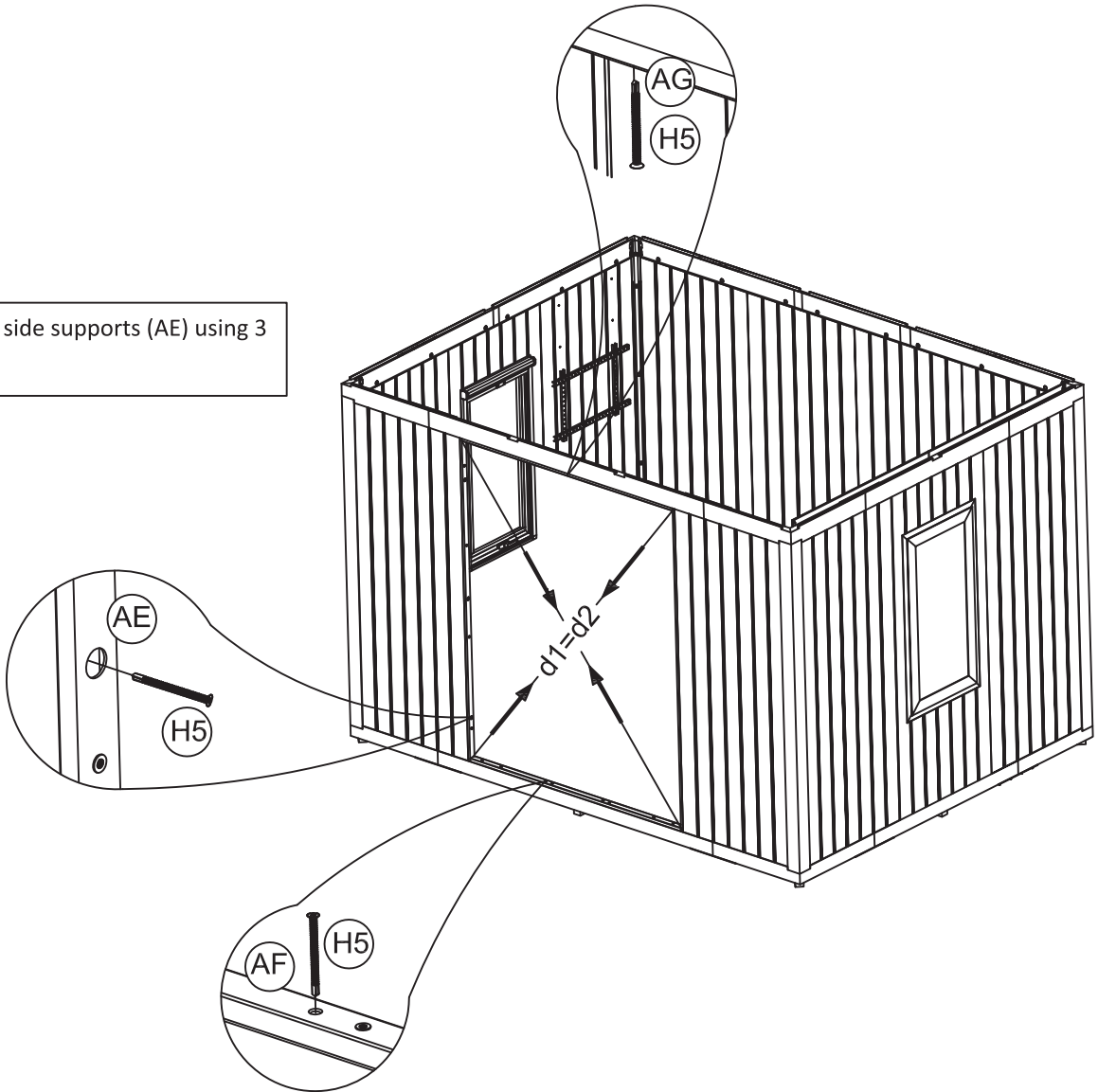

Secure the door bottom support (AF) using 4 bolts.

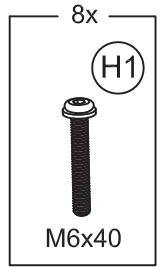
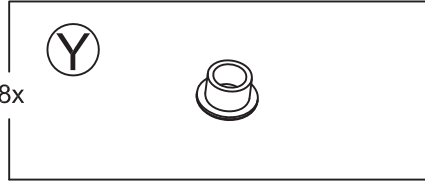
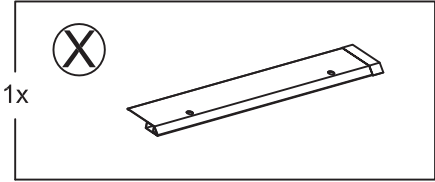
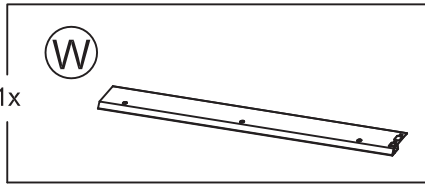
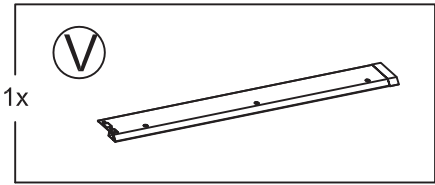

Insert all the bolts into the mounting holes but do not fully tighten. After ensuring all the parts are in the correct position, then finally tighten all the bolts to complete this step.

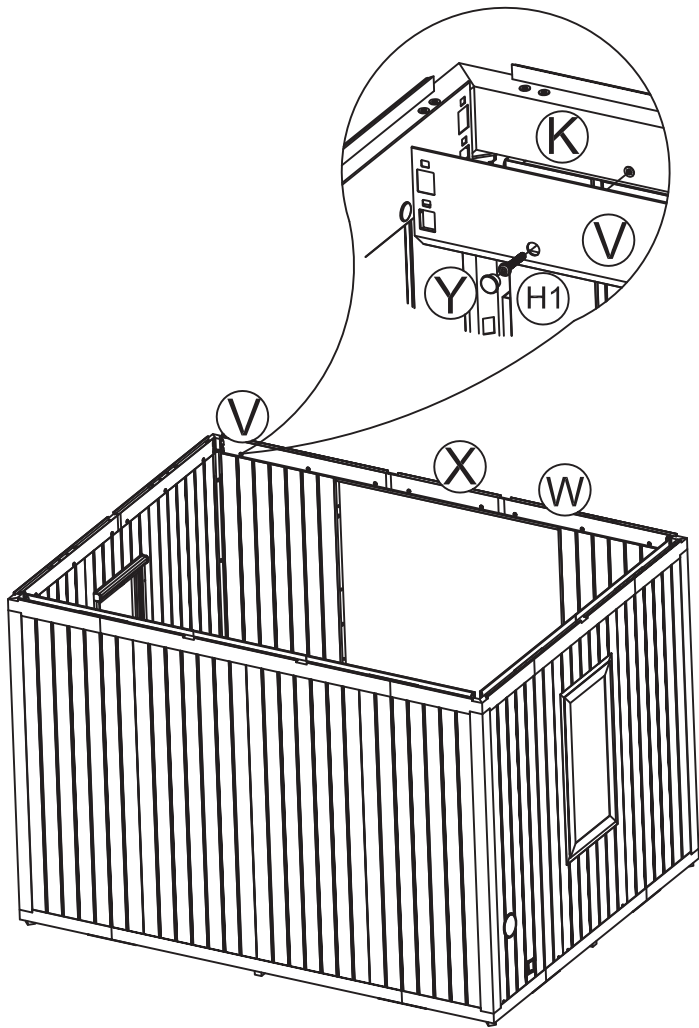

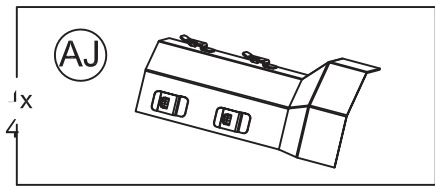

Apply the corner cover plate (AJ) from bottom up.

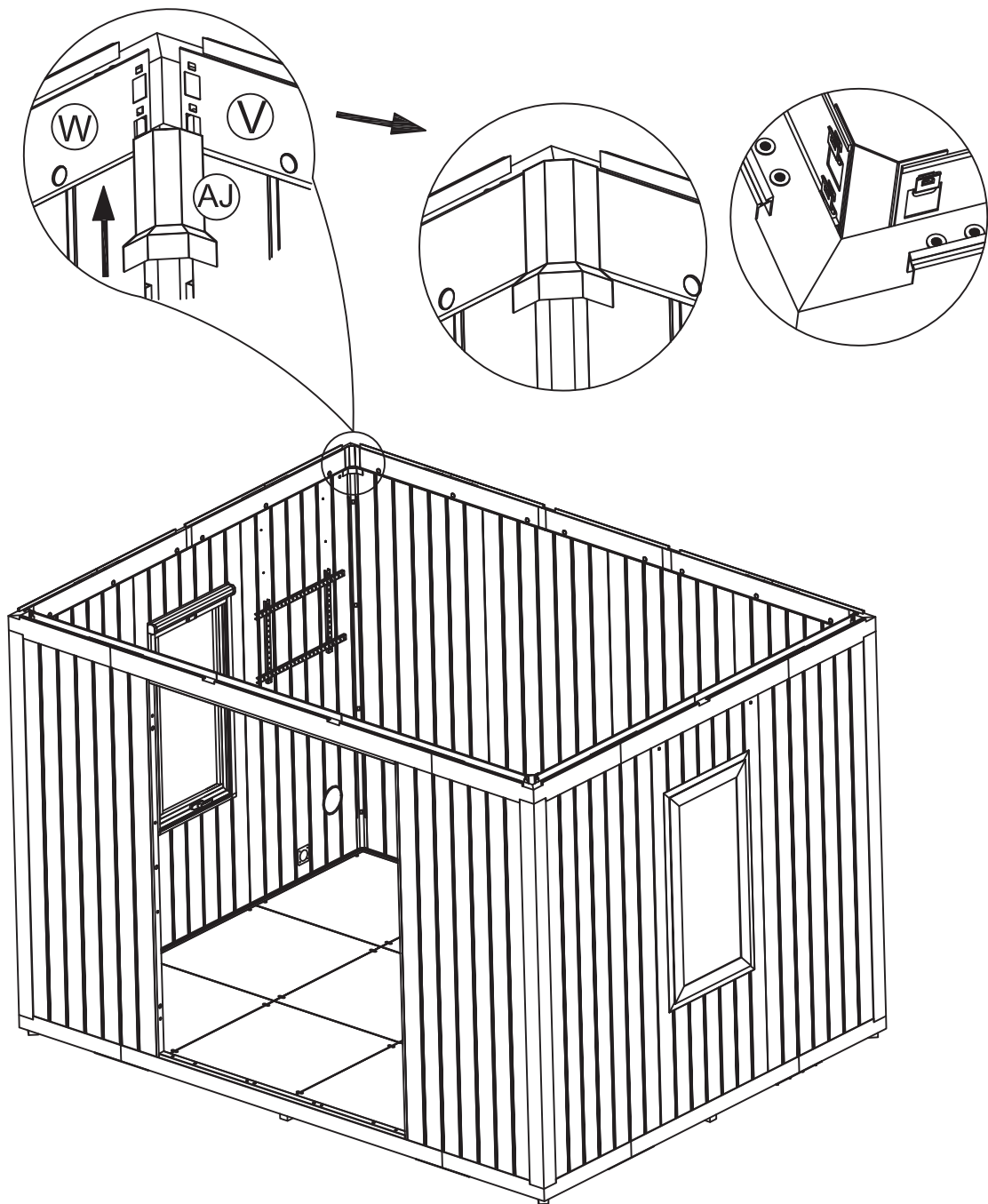

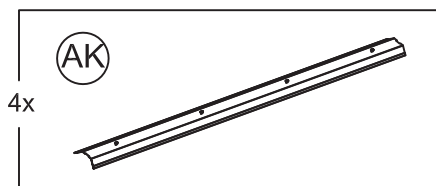

Lock the corner post cover (AK) from top to bottom into the post.

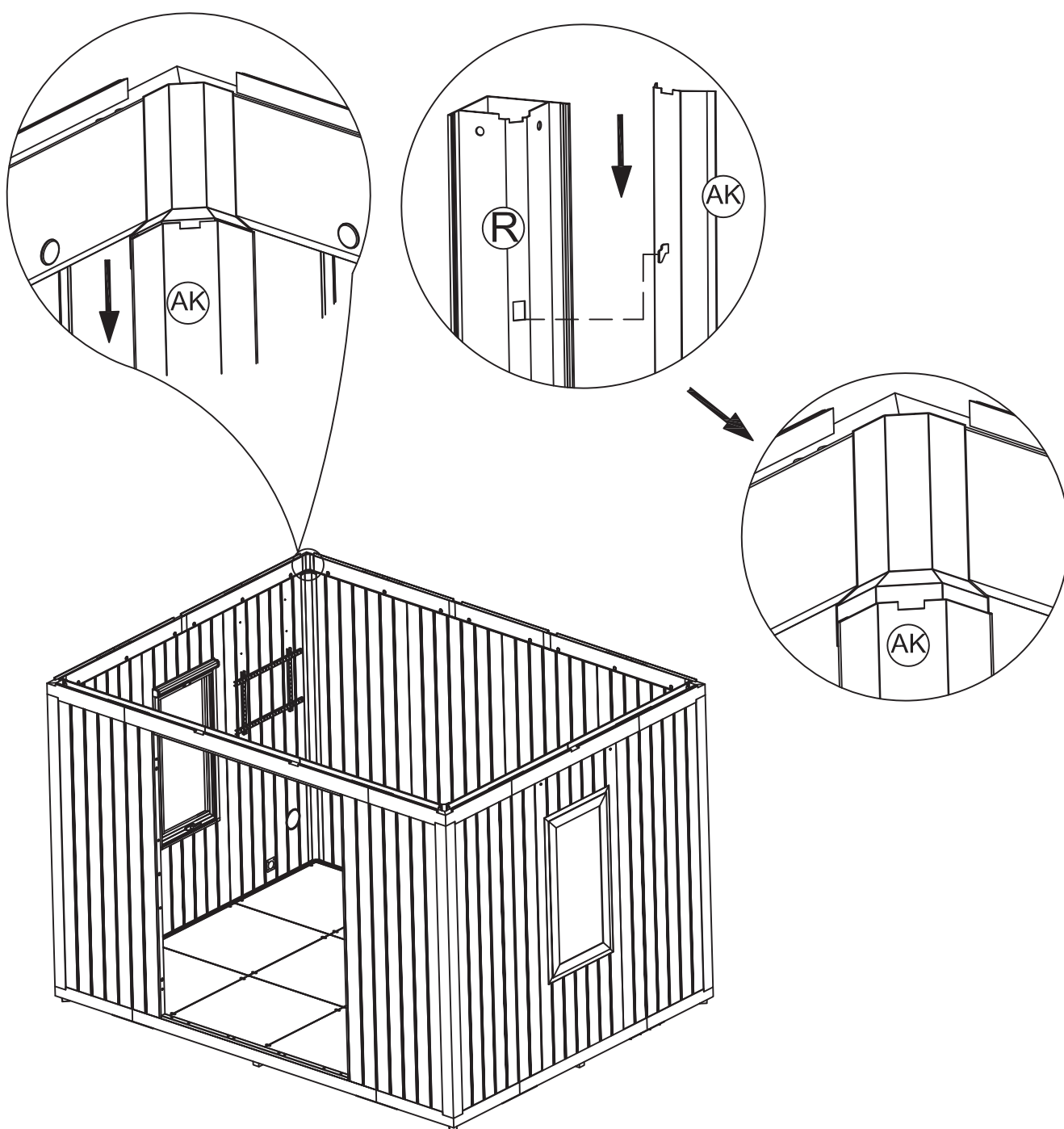

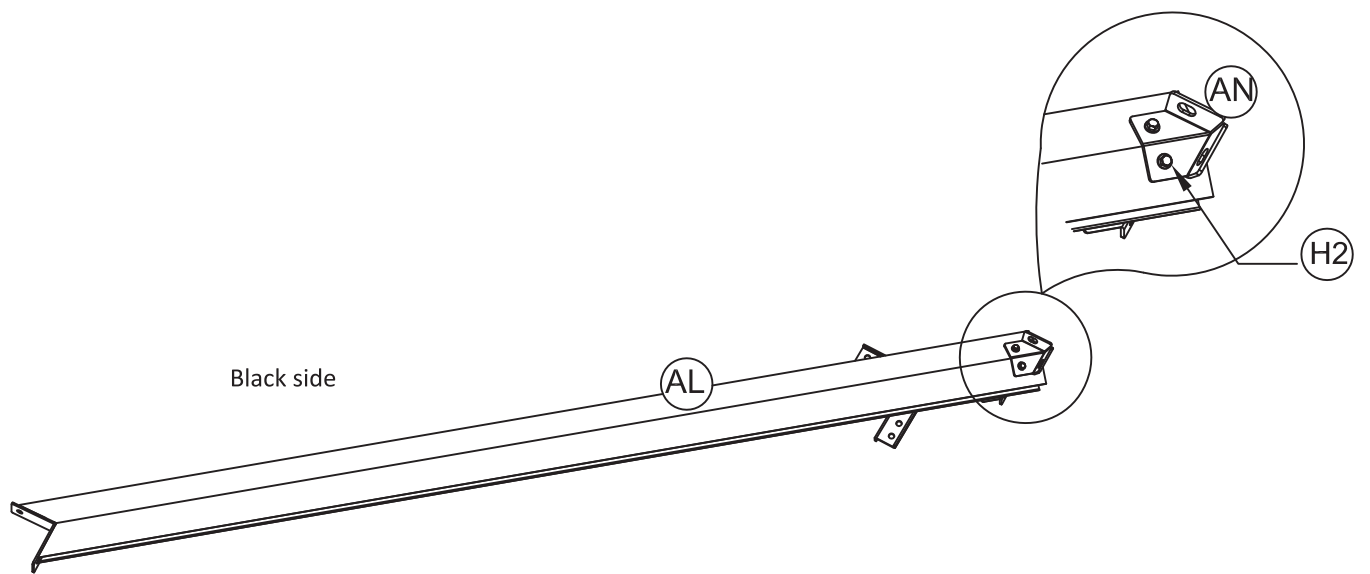
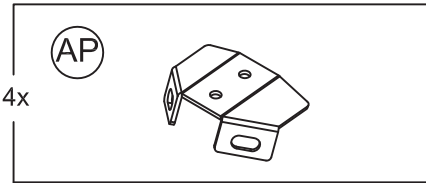
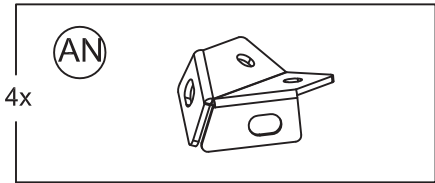
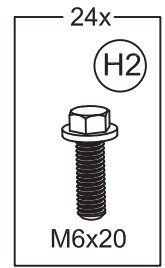
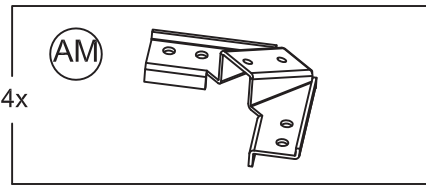
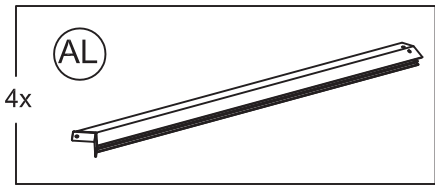

Note the colors for the incline roof beams (AL). Black side will be facing out, white side facing in.

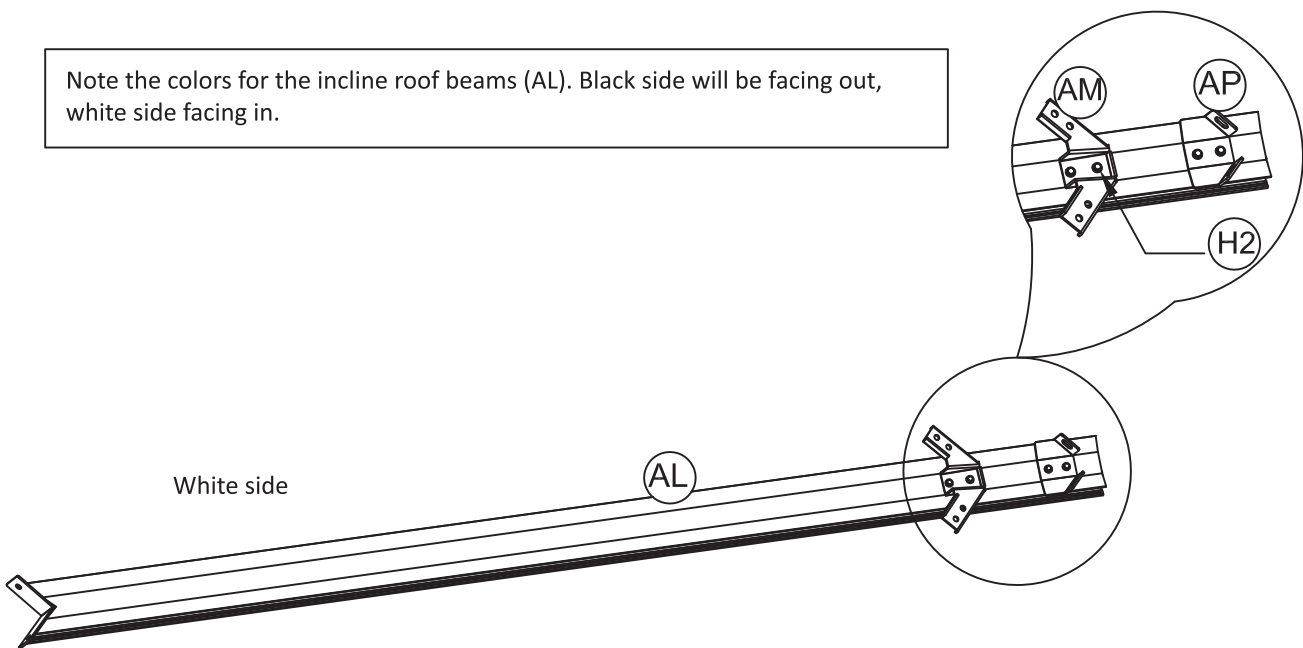

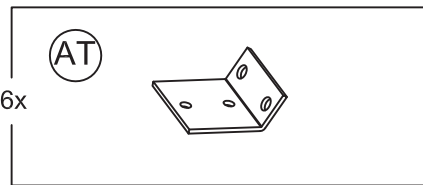
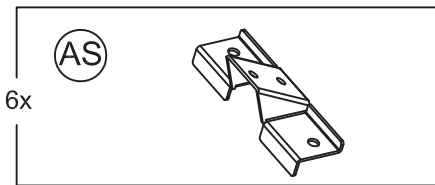
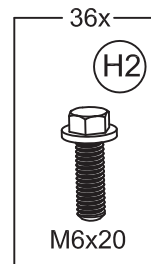
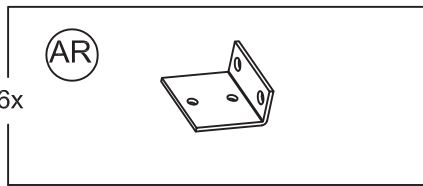
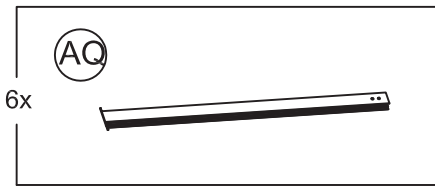

Note the colors for the middle roof beams (AQ). Black side will be facing out, white side facing in.

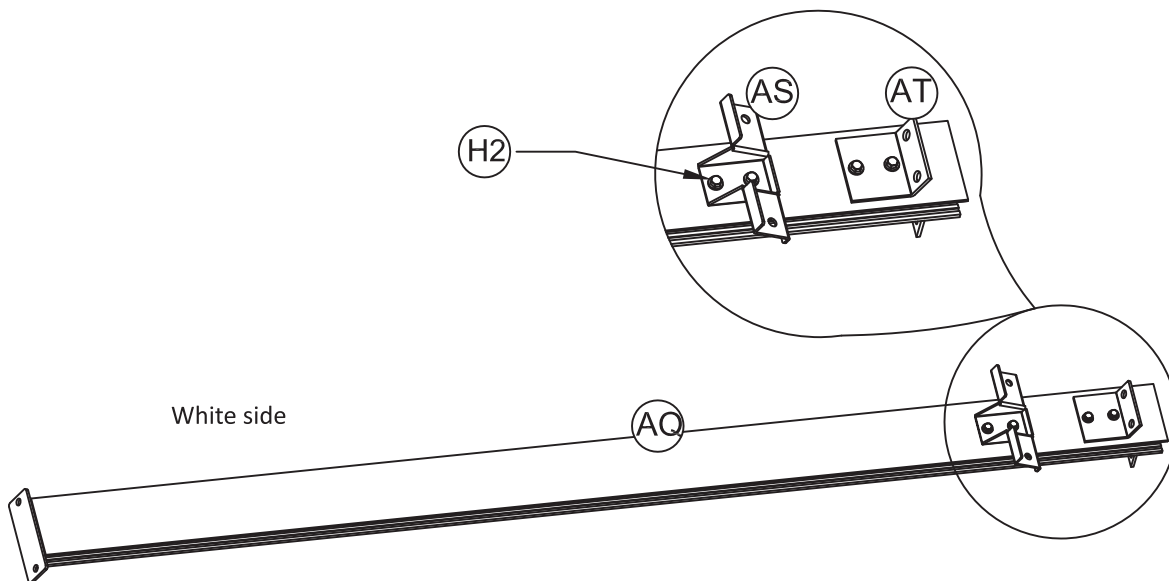
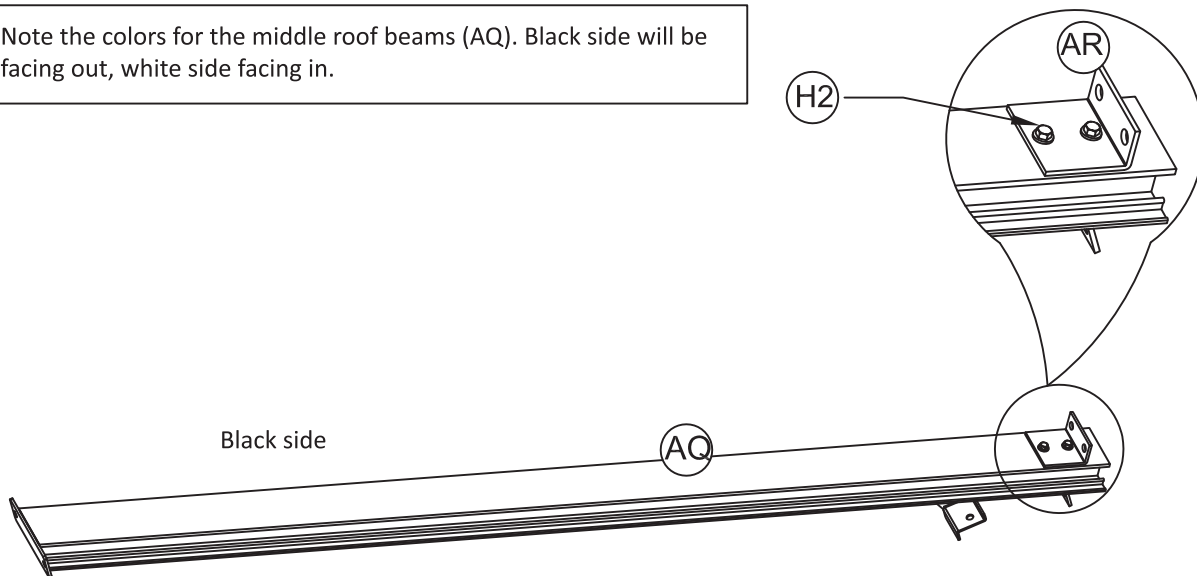

33

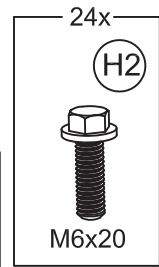
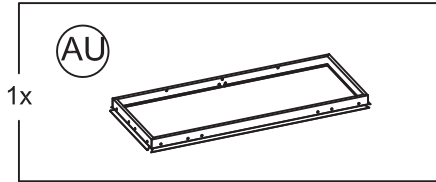

Connect incline roof beams (AL) to top frame and center roof frame (AU). Insert all the bolts into the mounting holes but do not fully tighten. After ensuring all the parts are in the correct position, then finally tighten all the bolts to complete this step.

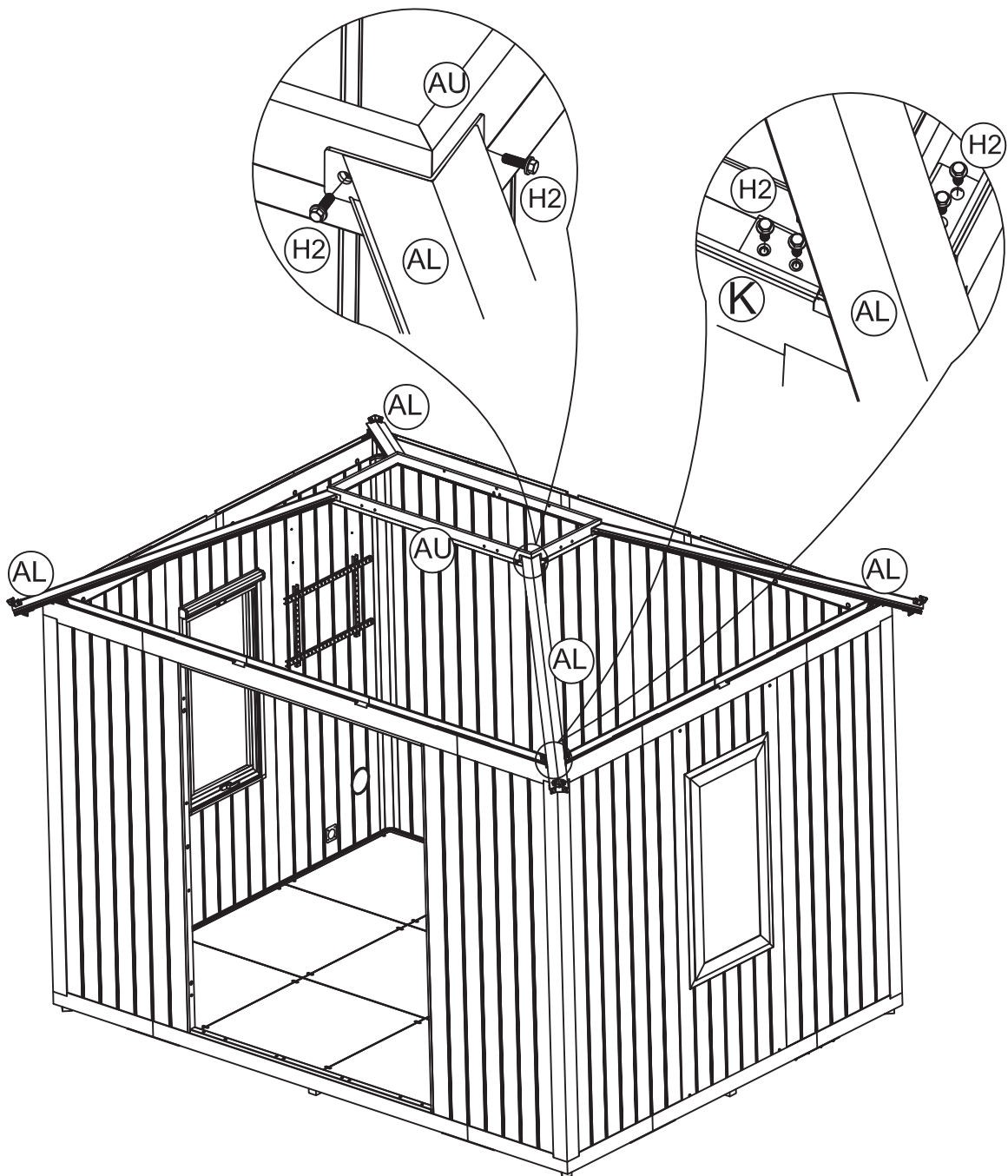

Connect middle roof beams (AQ) to top frame and center roof frame (AU). Insert all the bolts into the mounting holes but do not fully tighten. After ensuring all the parts are in the correct position, then finally tighten all the bolts to complete this step.

24x

(H2)

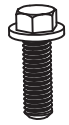

M6x20

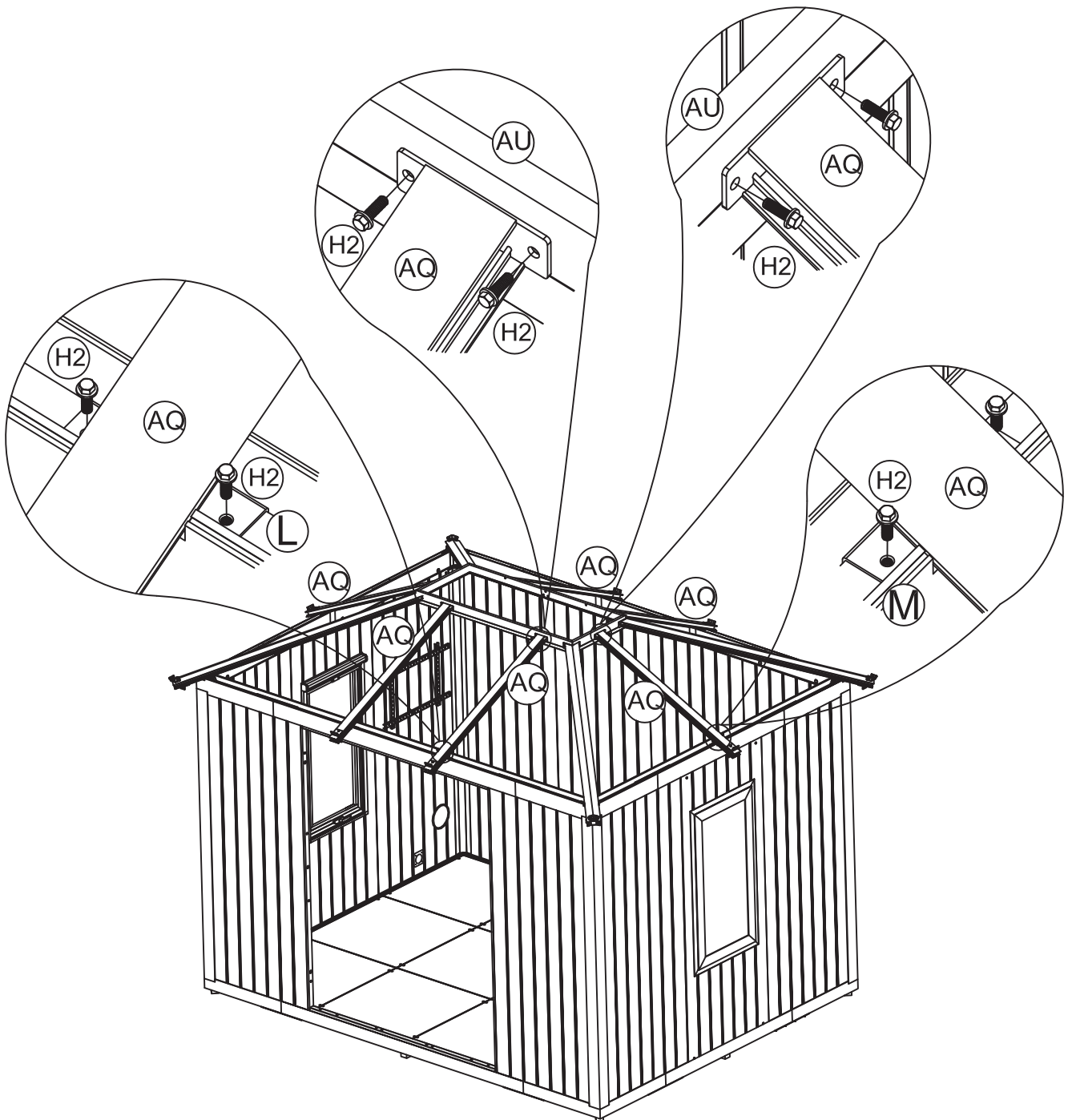

35

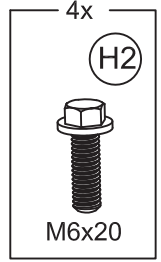
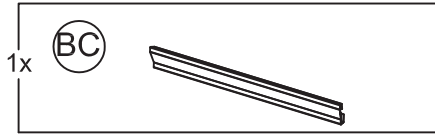
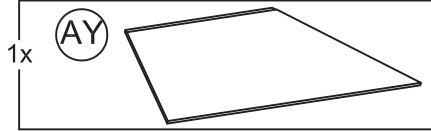
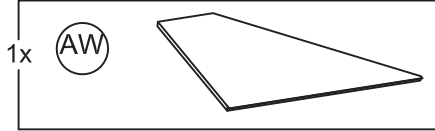

ATTENTION: ROOF PANELS MUST BE ASSEMBLED IN CLOCKWISE DIRECTION.

Ensure the white side of the heat shield roof facing inside, and black facing outside.
Insert the bolts into the mounting holes but do not fully tighten them yet.

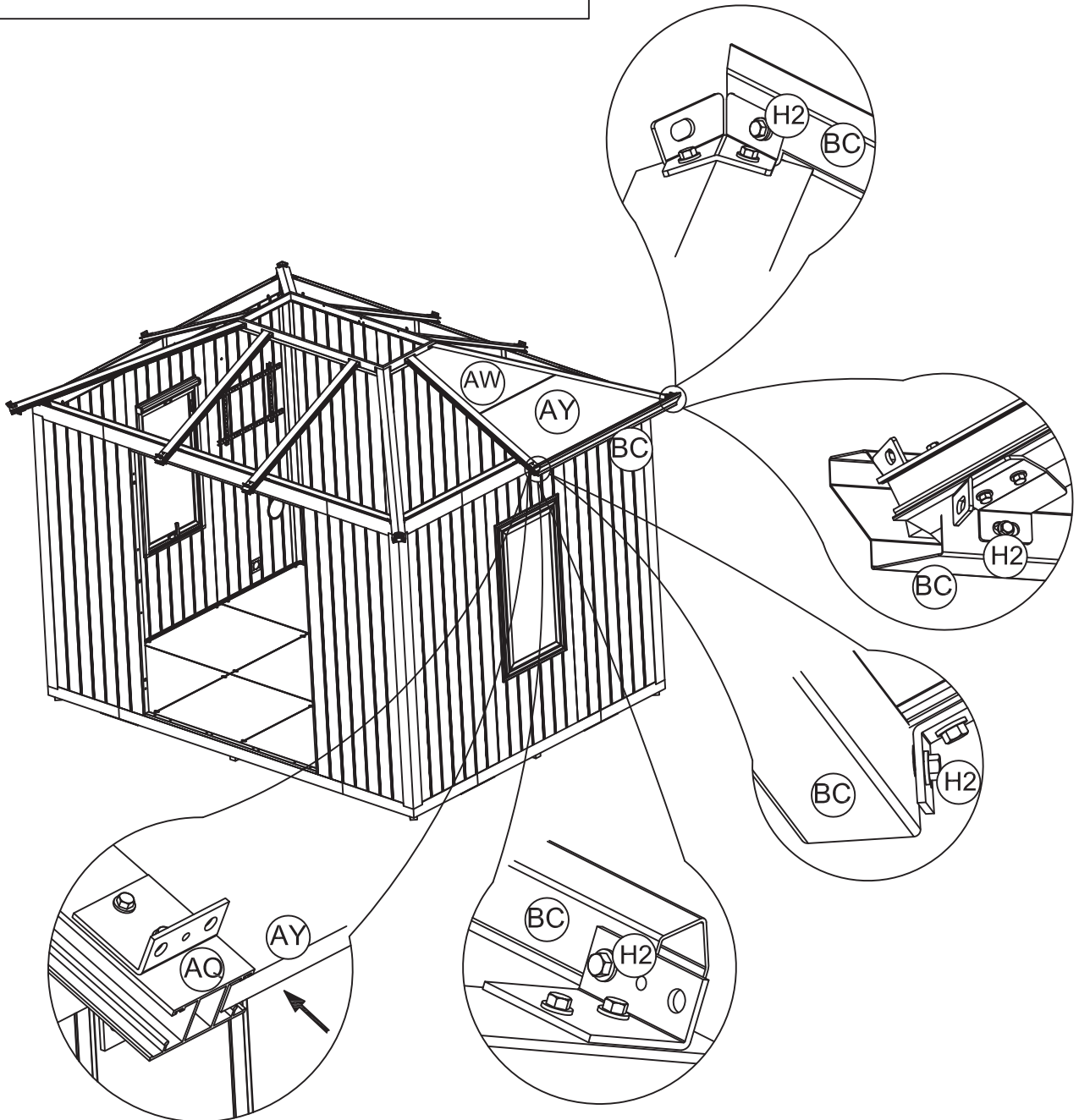

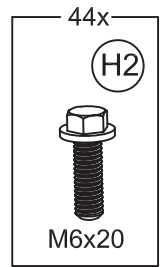
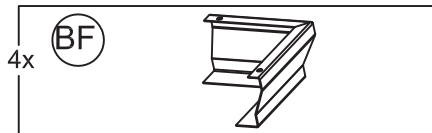
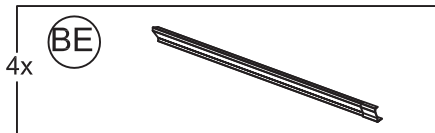
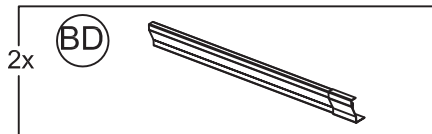
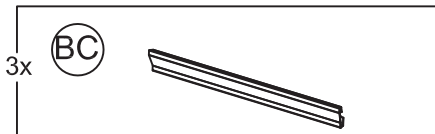
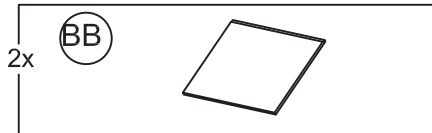
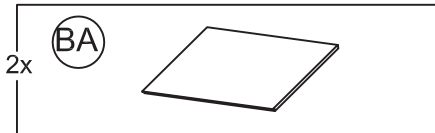
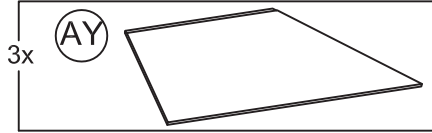
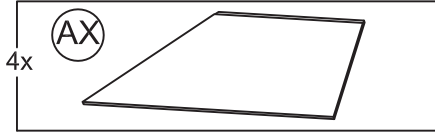
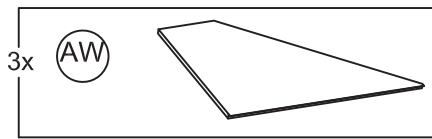
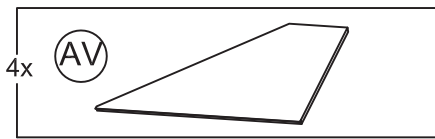

After all the roof panels are in place and secured with a bolt you can proceed to tighten all the bolts.

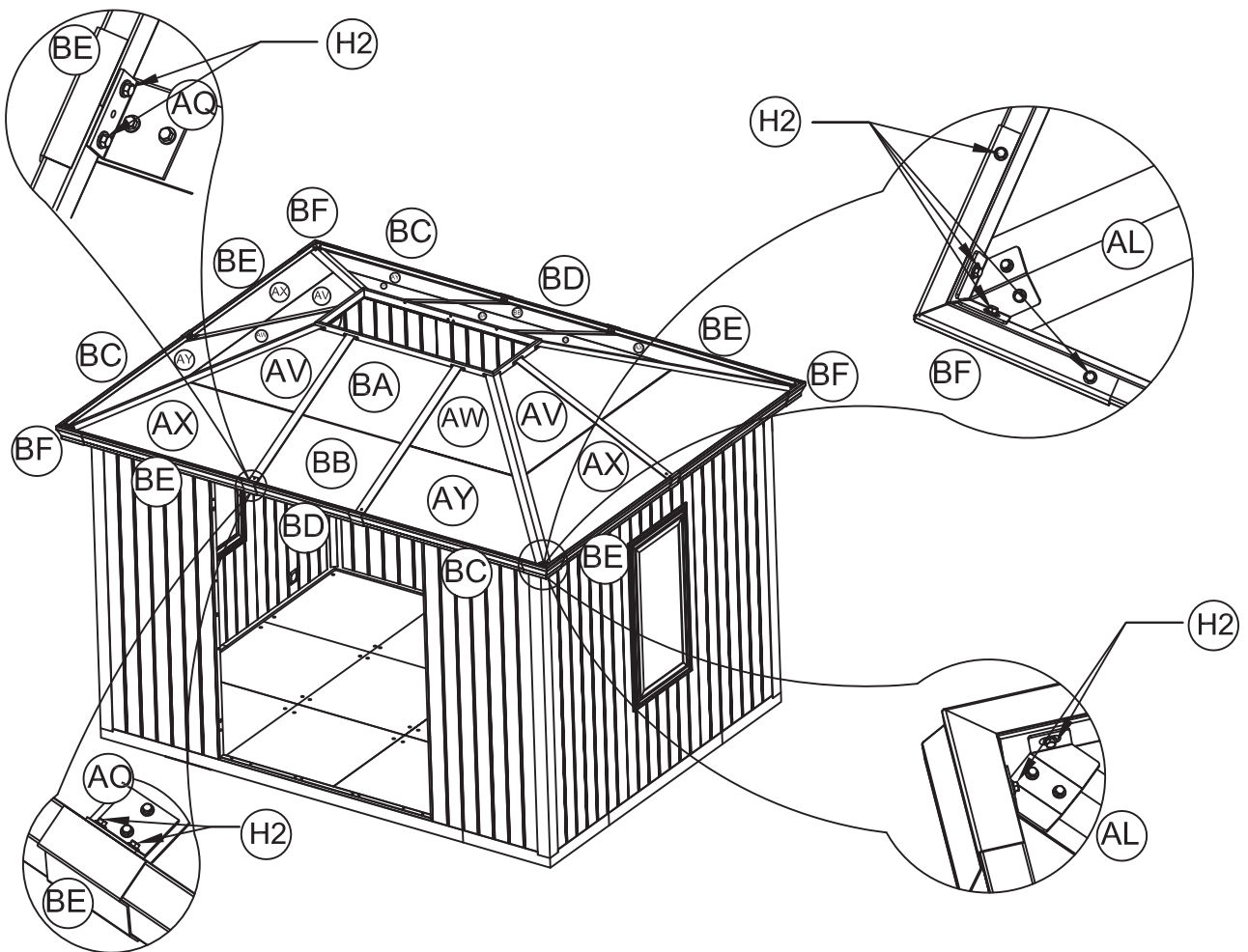

37

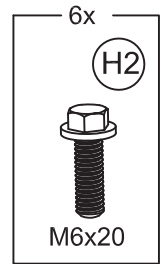
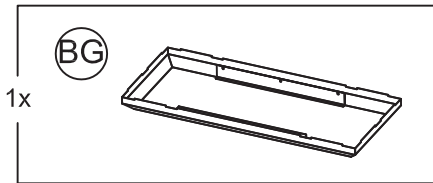

ATTENTION: CAREFULLY INSTALL THE CENTER ROOF COVER (BG) FROM INSIDE THE SHED. DO NOT CLIMB ONTO THE ROOF!

Using a ladder, carefully guide the center roof cover (BG) through the opening in the ceiling, to place it on the top.

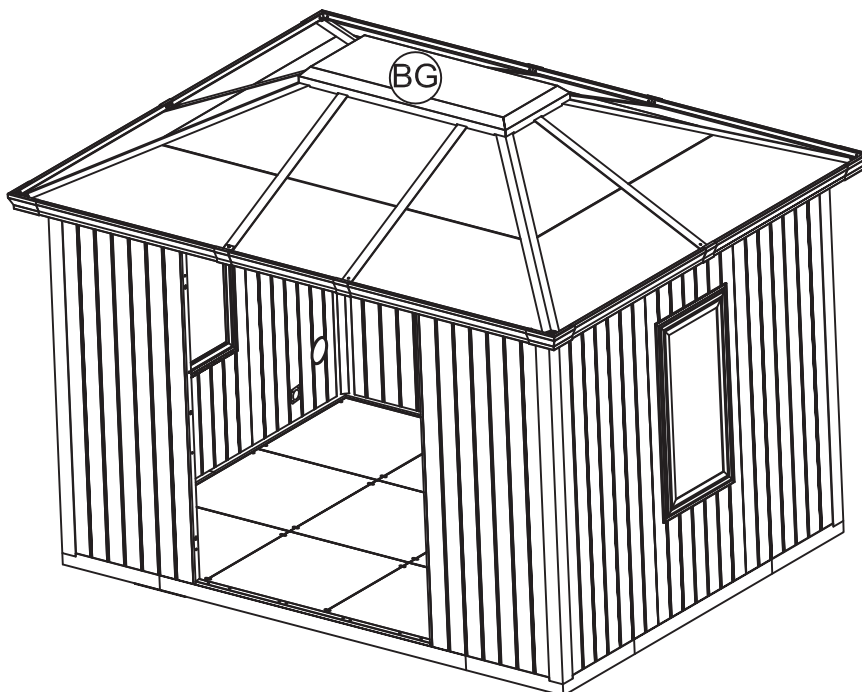
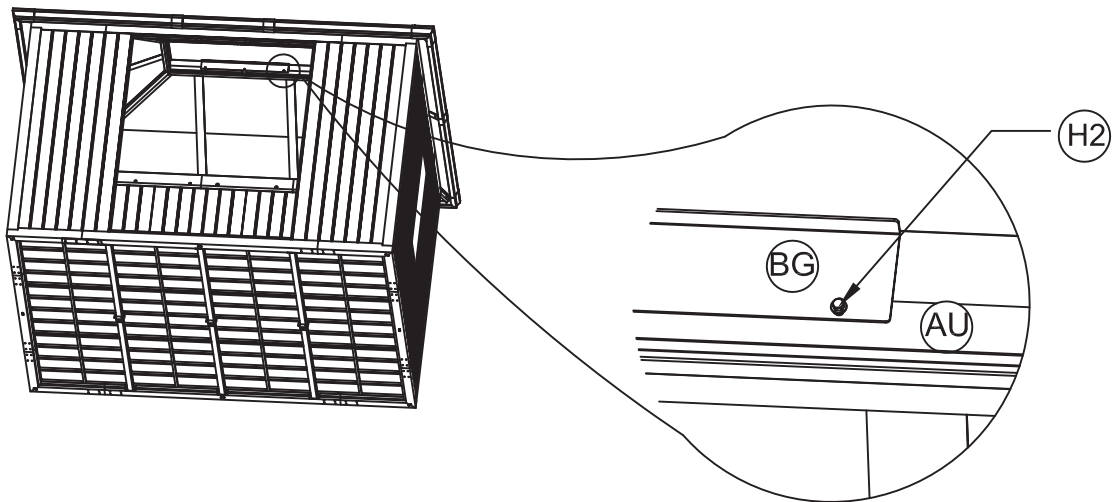

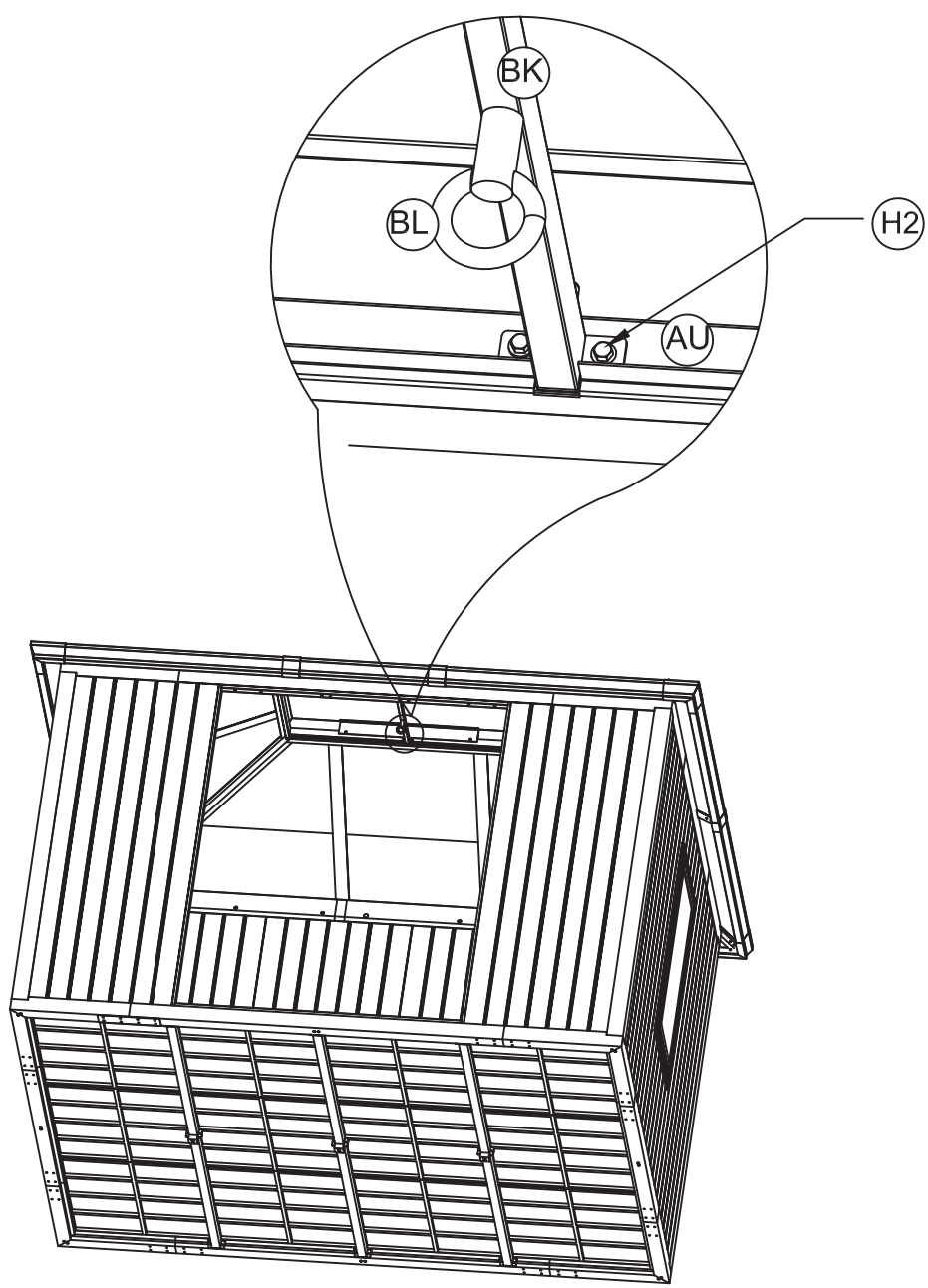
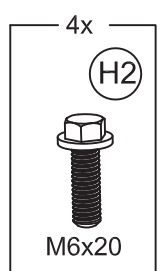
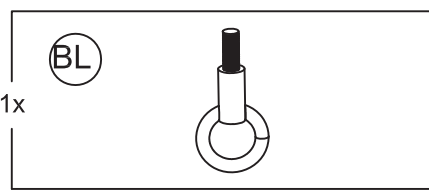
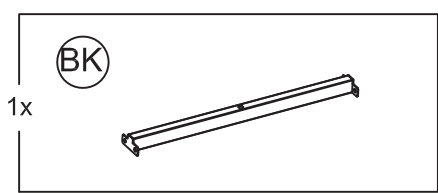

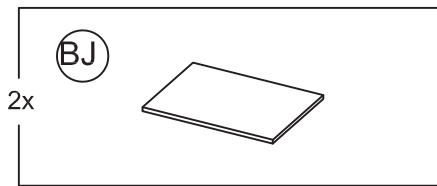

Carefully tilt the roof heat shields (BJ) to guide them into place on the center roof frame.

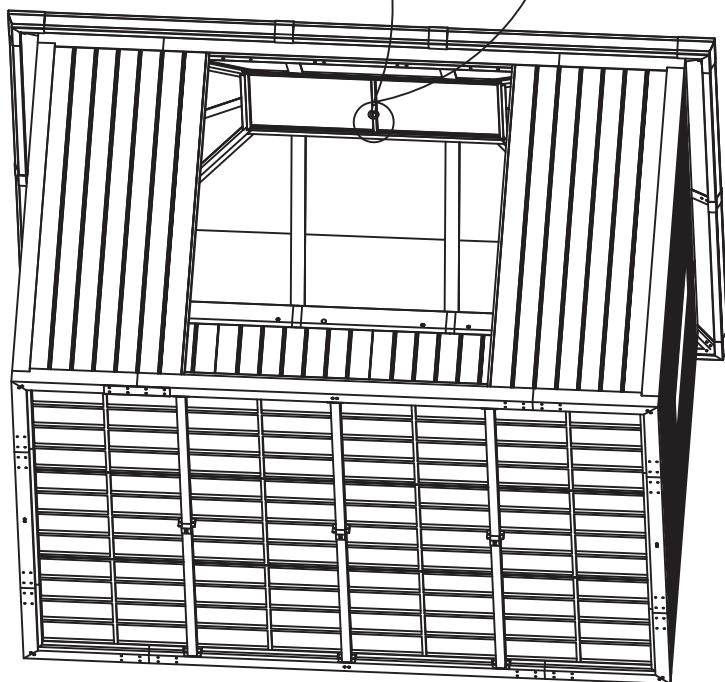
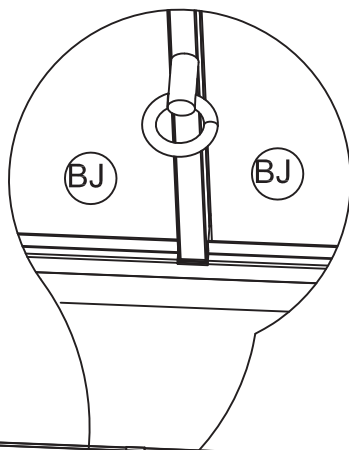
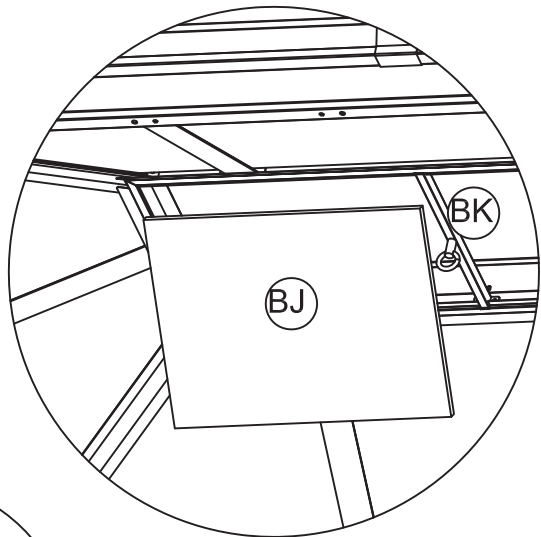

Doors must be removed from the doorframe to proceed with the installation. 2-3 people are required to do this step.

Carefully lay them down on soft surface, level floor with the outward opening facing up.

Open one door 90 degrees and carefully push it out of its hinges in the direction shown by the arrow, which will release the door. Place it in a safe spot temporarily. Follow the same steps with the other door.

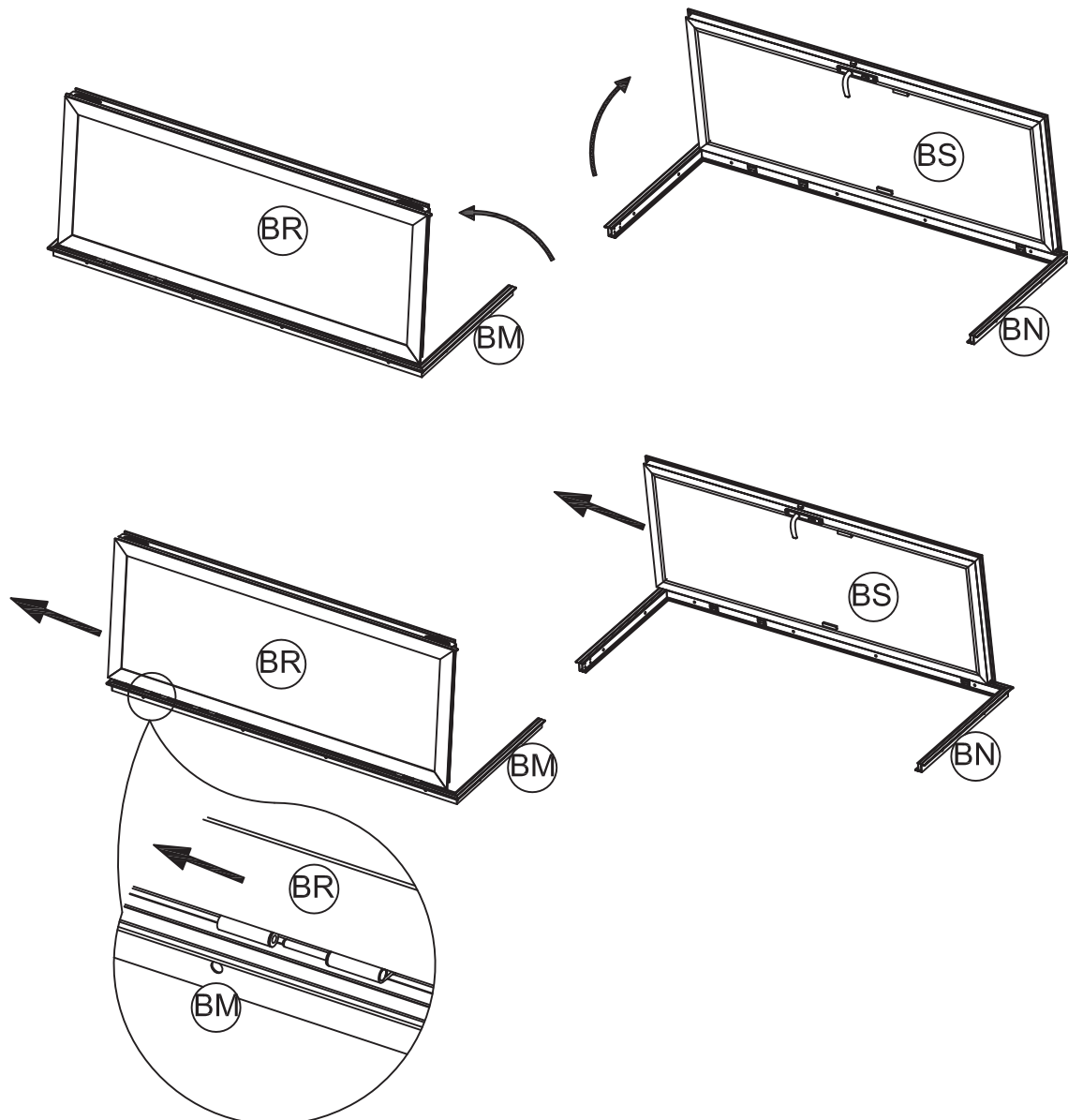

41

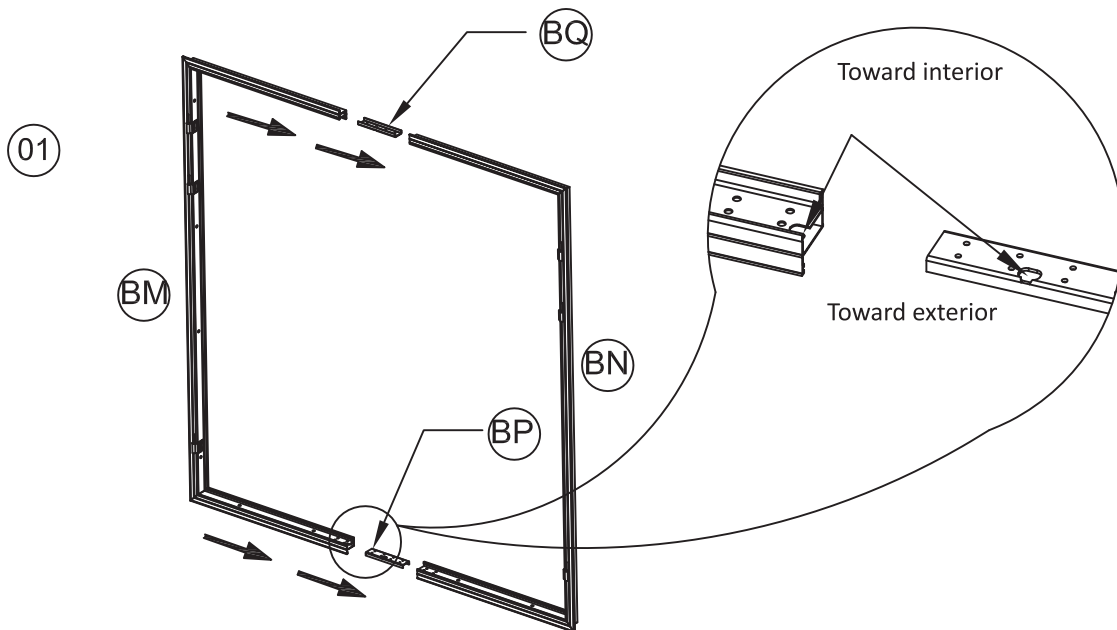
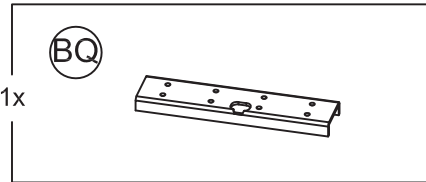
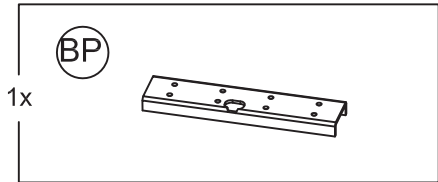
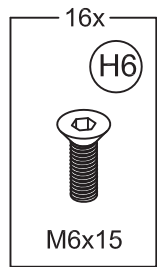
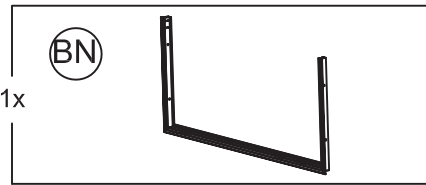
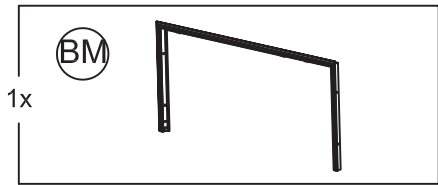

Install the door frame connectors (BP/BQ) to the door frames (BM/BN) making sure the lock pin hole is facing the right direction (pin holes should be towards the exterior)

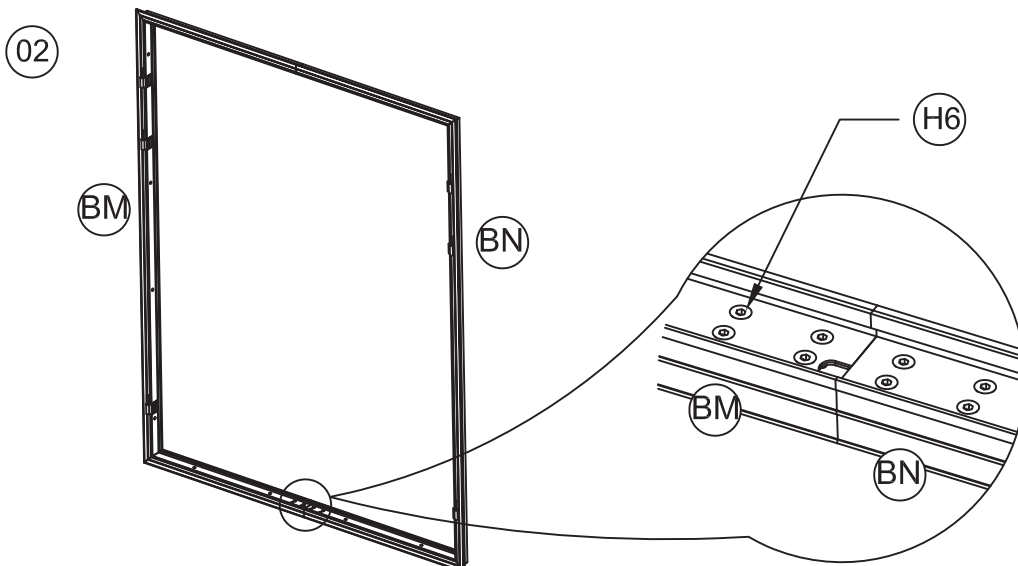

Insert all the bolts into the mounting holes but do not fully tighten until they are all in the correct position. Once everything is in place, tighten all the bolts.

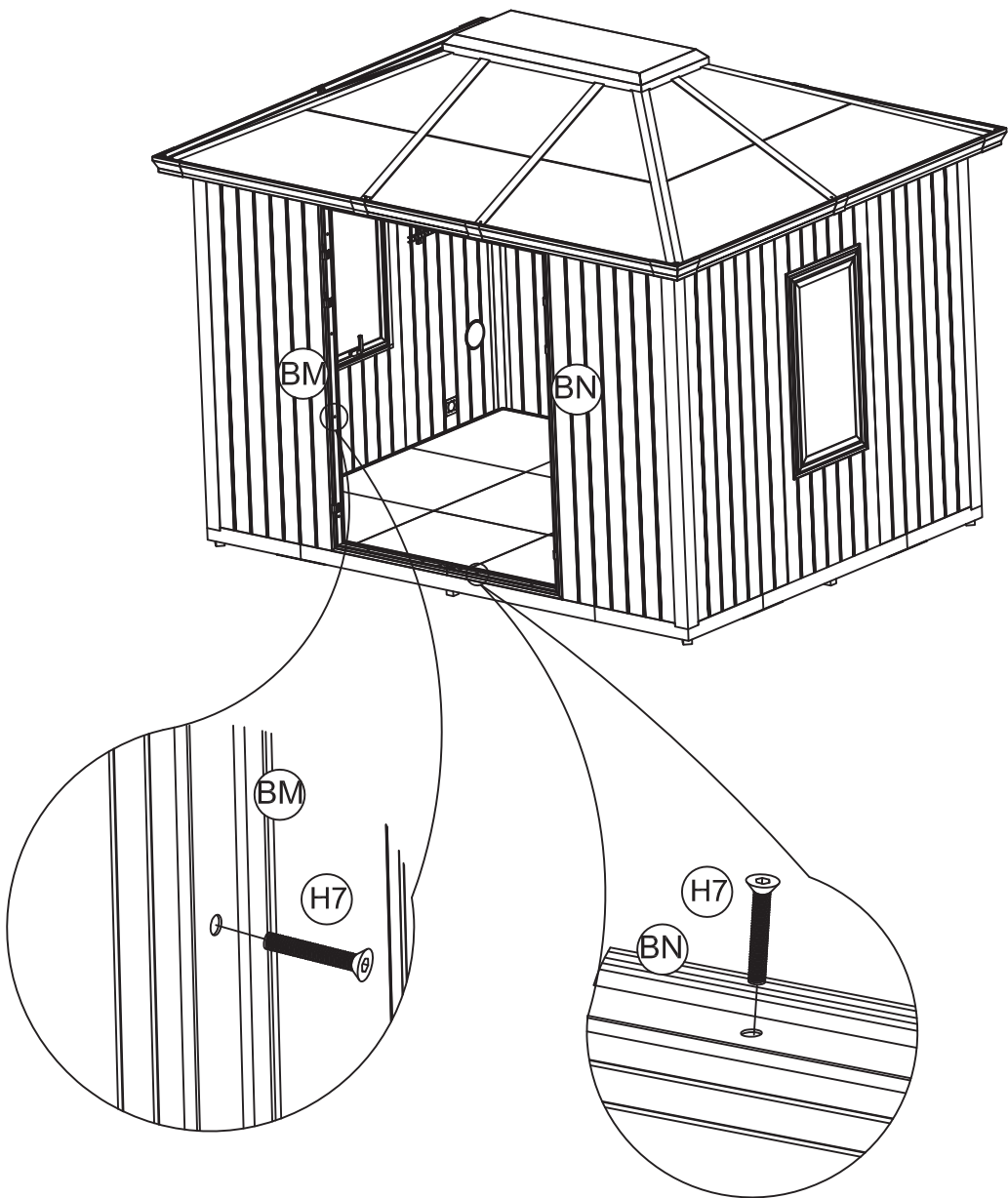
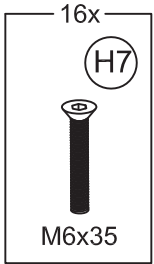

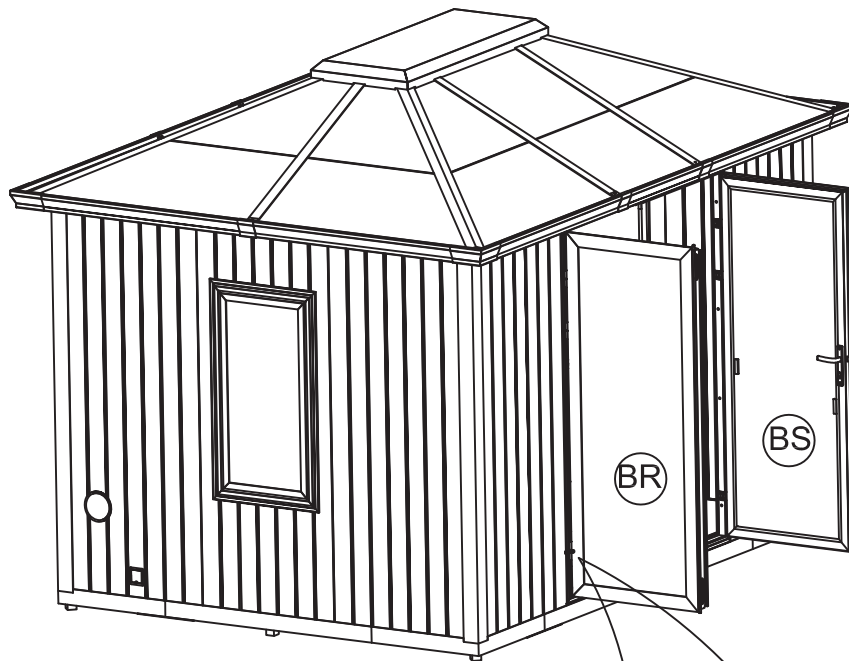
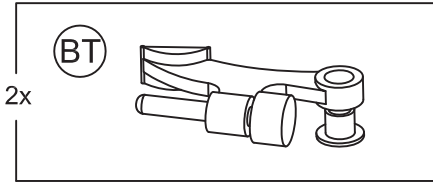
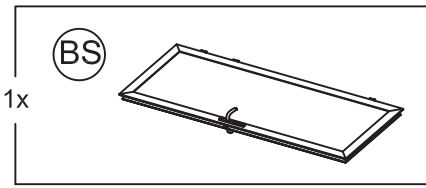
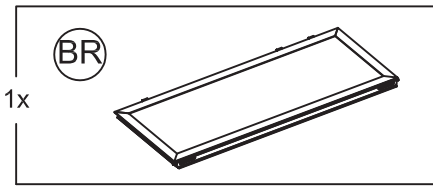

Insert the door stopper (BT) into the lower hinge of the door frame. Then 2 people are required to lift the door and carefully guide the door hinges into the frame hinges, from top to bottom. Repeat the steps with the other door.

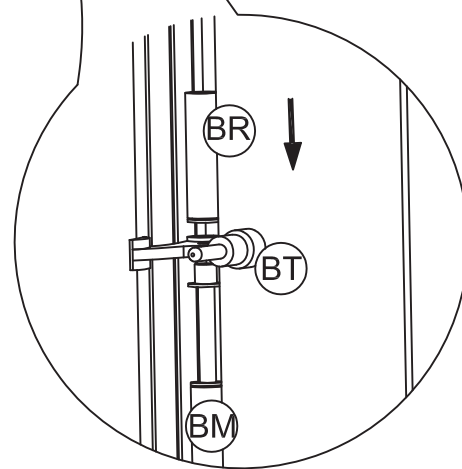

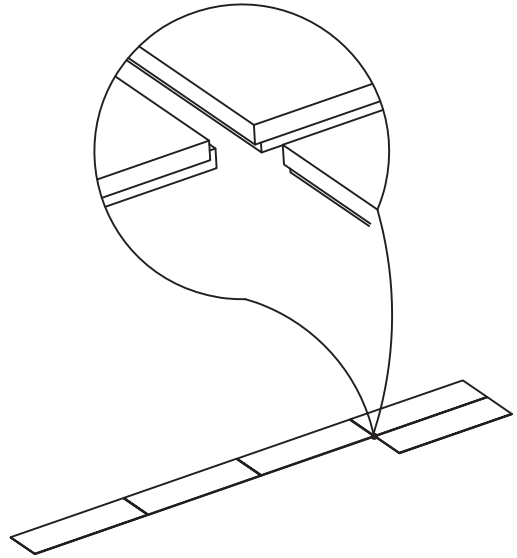
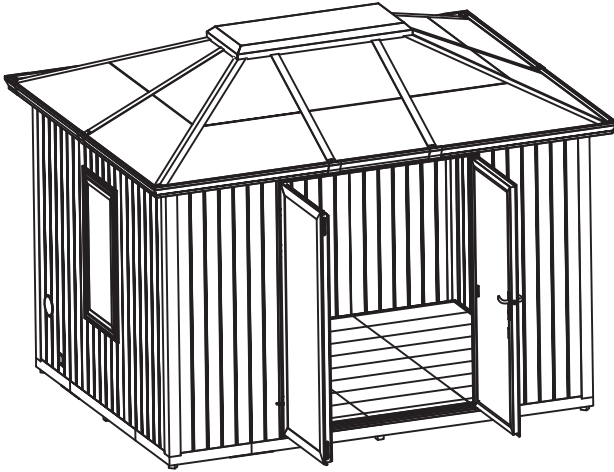
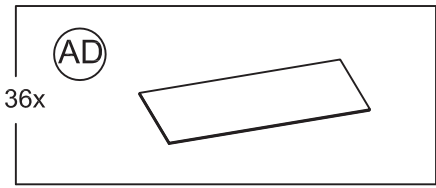

Install the first row of SPC floor starting at the left or right of the unit. Once the first row is secured proceed with the next row, completing the remaining row by row until finished.

Scan this QR code for video instructions for this floor assembly.

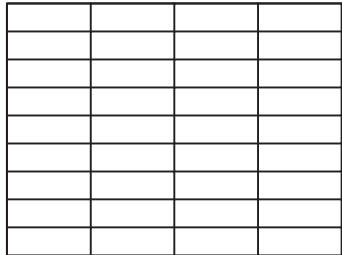
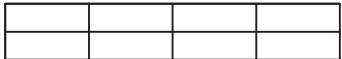
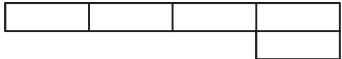
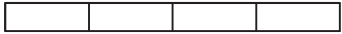

Scan this QR code for further instructions and video demonstration of the window functions and features.

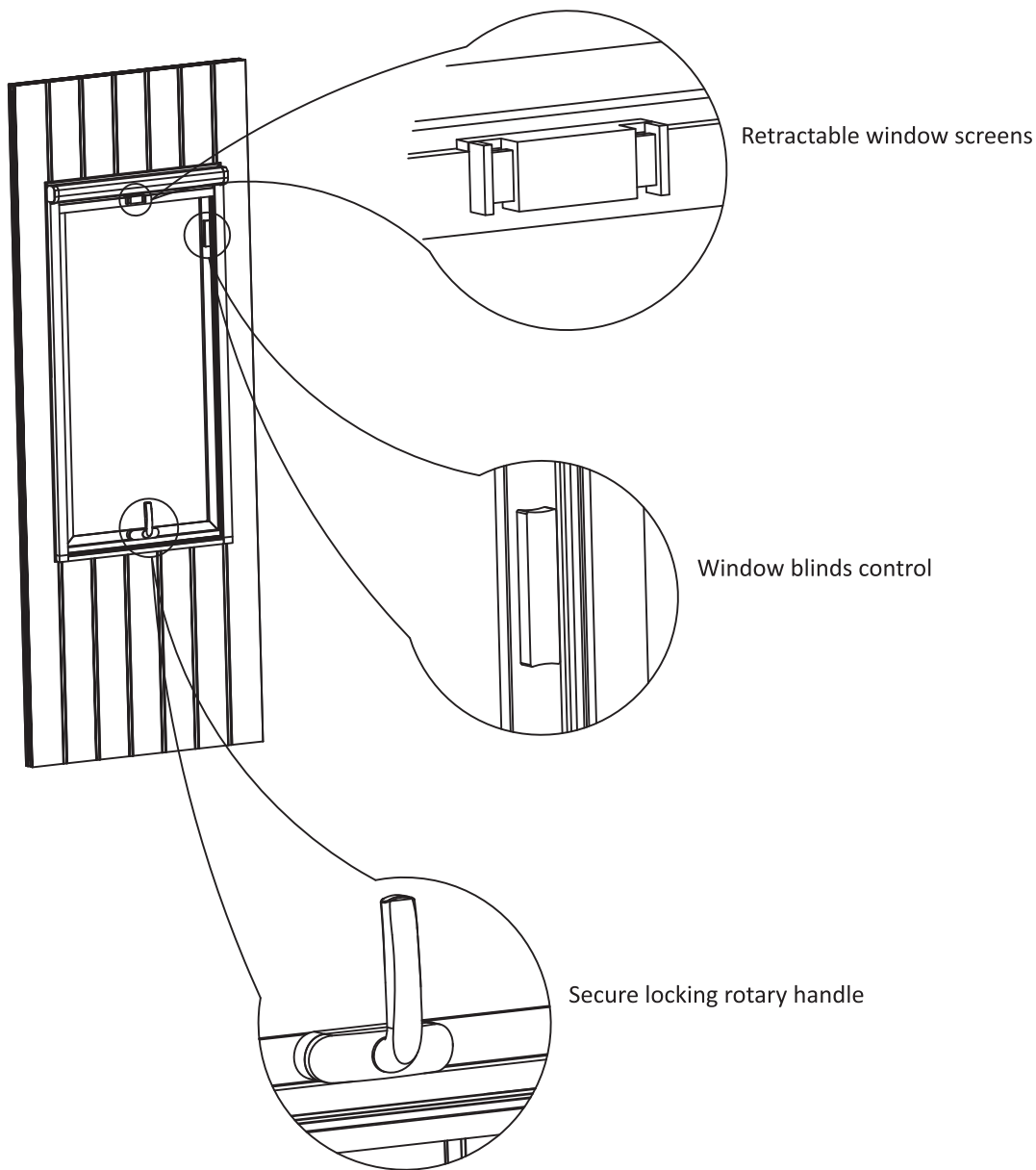

Scan this QR code for further instructions and video demonstration of the door functions and features.

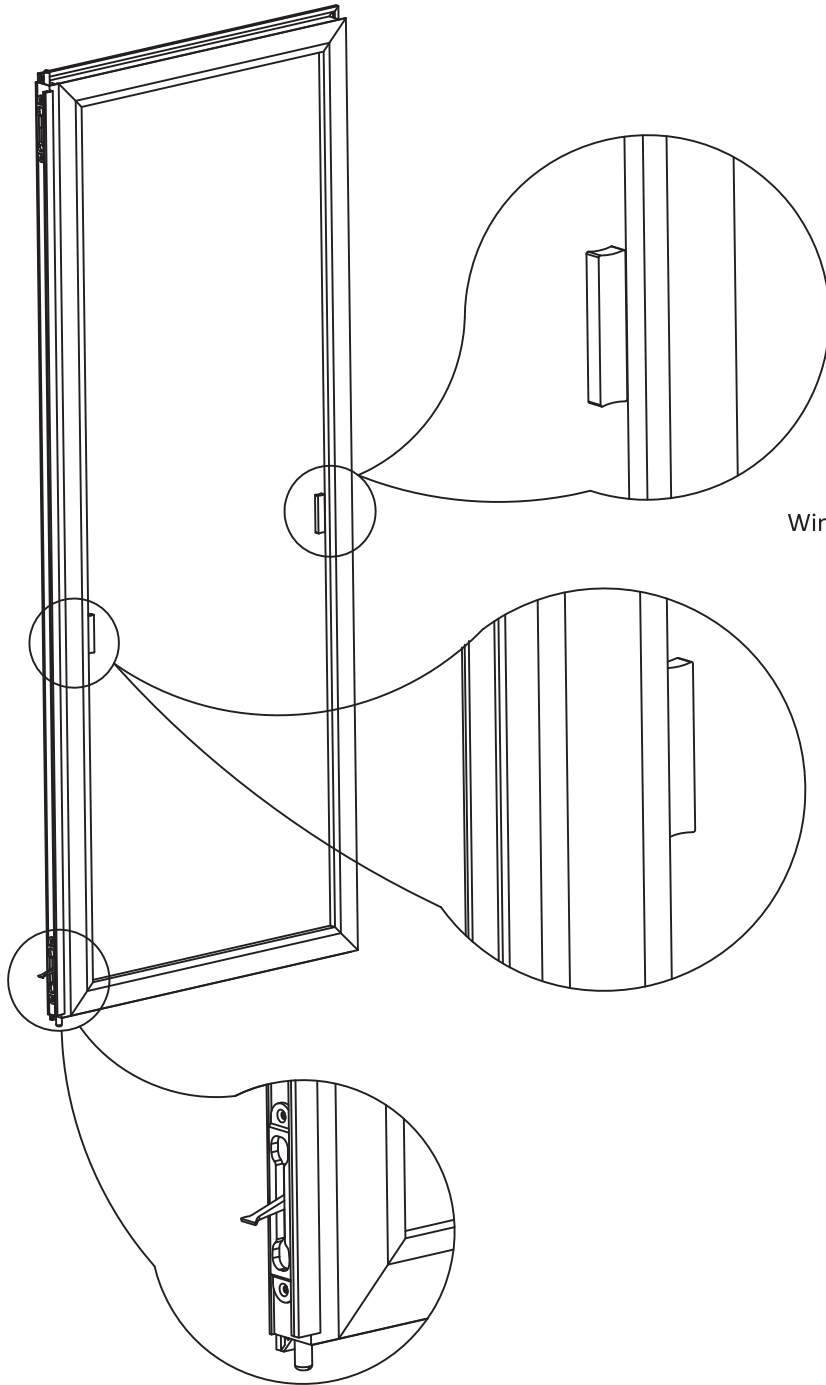

Window blinds control

Two deadbolt locks on the upper and lower ends of the door.