

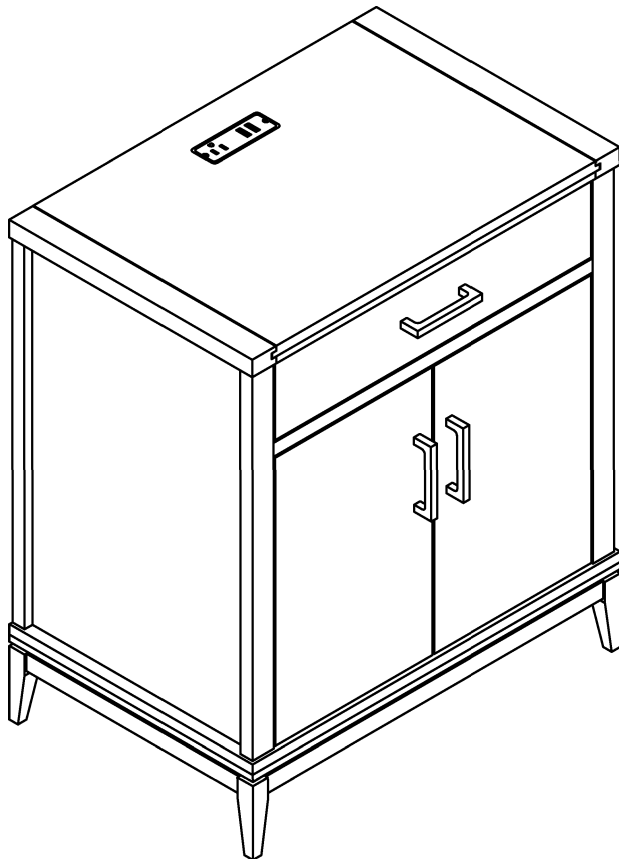







Assembly Instructions, Side Table

Note:

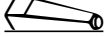
A packet with complete set of hardware can be found by pulling the red ribbon that's easily visible upon opening the box.

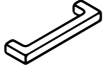

Parts List

A	Top Assembly		1
B	Adjustable Shelf		1
C	Legs		4
D	Bolts		4
E	Lock Washers		4
F	Flat Washers		4
G	Allen Wrench		1
H	Handles		3
I	Machine Screws		6
J	Shelf Supports		4

Step 1

- 1.1)** Place the top assembly (A) up side down on a soft surface, fasten the legs with 4 four bolts, lock washers and flat washers.
- 1.2)** Put the side table upright with the door facing up as shown by arrow in below.

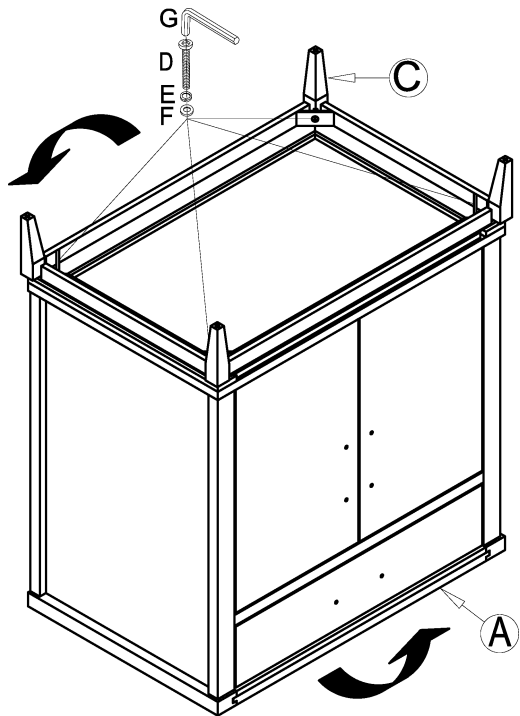

Step 2

- 2.1)** Open the drawer and doors, install three handles on drawer front and doors.

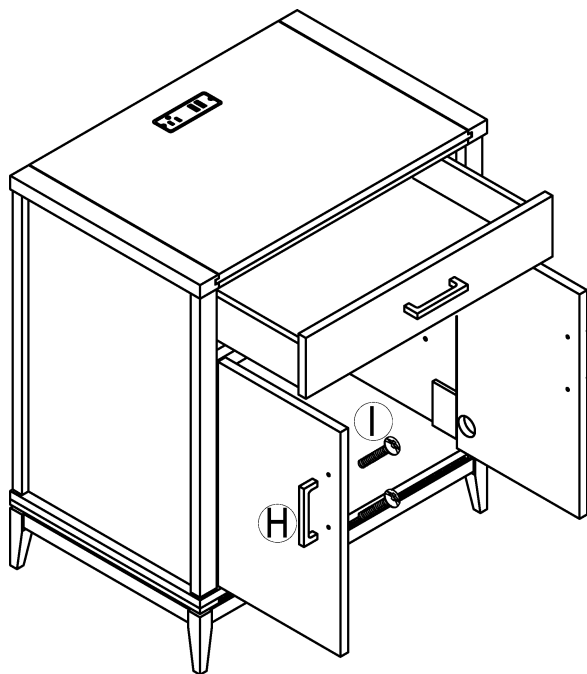

Step 3

- 3.1)** Insert shelf supports on shelf holes and place the shelf on shelf supports.

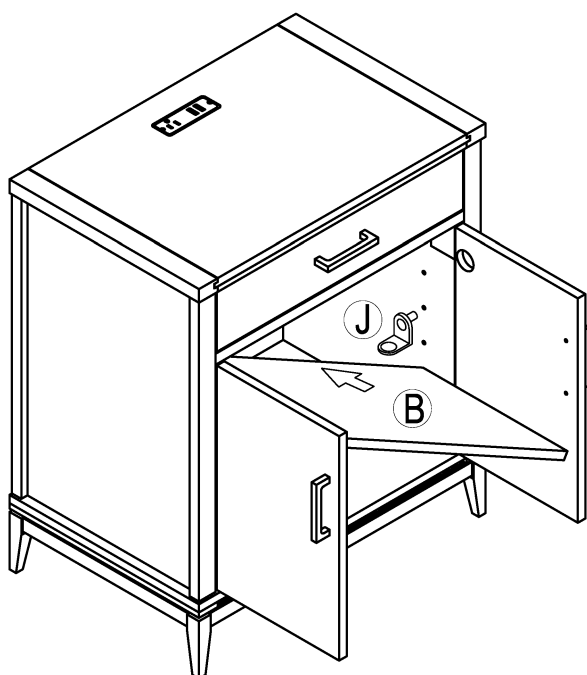

Step 4

- 4.1)** Adjust the levelers at the bottom of legs if needed.

