

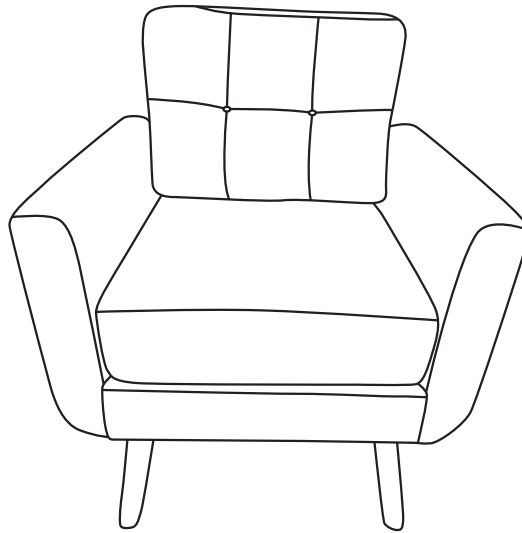

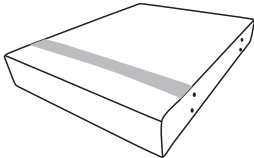



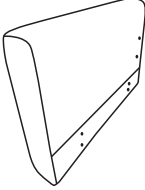
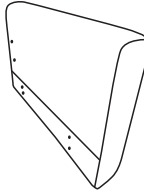
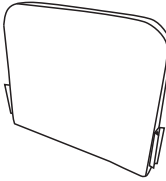
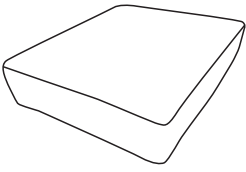
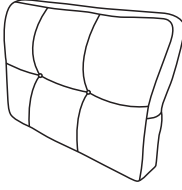

# ASSEMBLY INSTRUCTION

## CHAIR

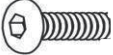

### PARTS LIST

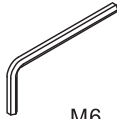
<b>A</b>  Tips:  Velcro 1PC	<b>B</b>  1PC	<b>C</b>  1PC	<b>D</b>  1PC	
<b>E</b>  1PC	<b>F</b>  1PC	<b>G</b>  4PCS	<b>H</b>  4PCS	
<b>J</b>  2PCS	<b>K</b>  M6x18mm 16PCS	<b>L</b>  M6x35mm 8PCS	<b>M</b>  ø6x18mm 4PCS	<b>N</b>  M6 1PC

## Installation Steps

### STEP 1

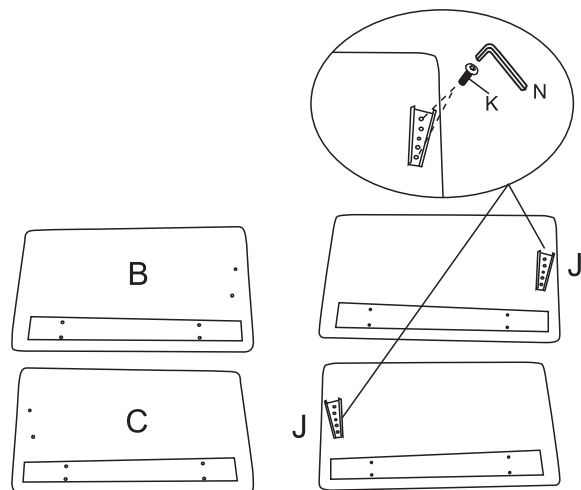

Attach part J to the screw holes of B and C using parts K and N.

### STEP 2

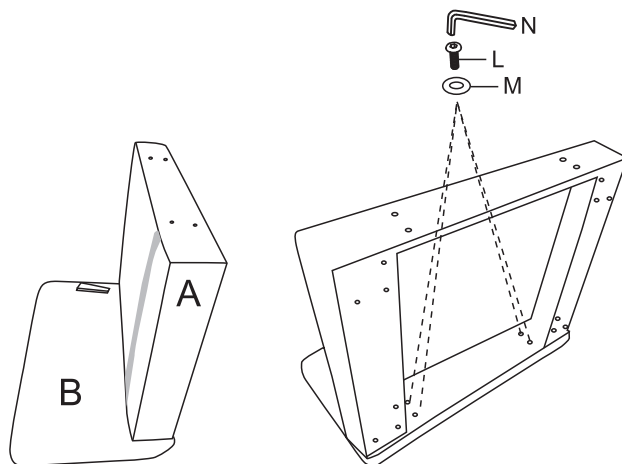

Align the screw holes in parts A and B. Insert part L into the holes of part M and the corresponding screw holes. Tighten the screws with part N.

### STEP 3

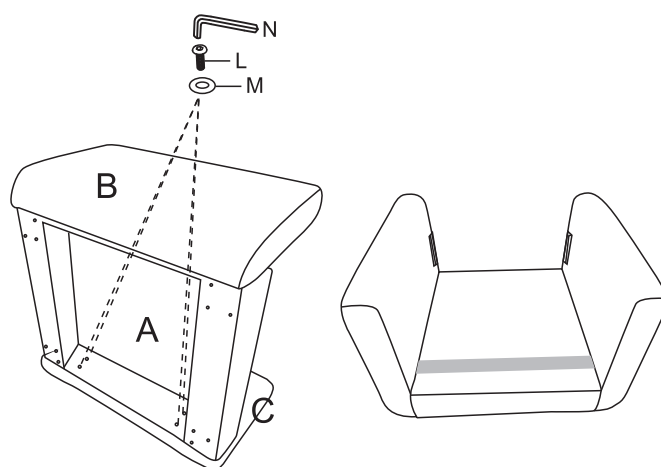

Align the screw holes in parts A and C. Insert part L into the holes of part M and the corresponding screw holes. Tighten the screws with part N.

## Installation Steps

### STEP 4

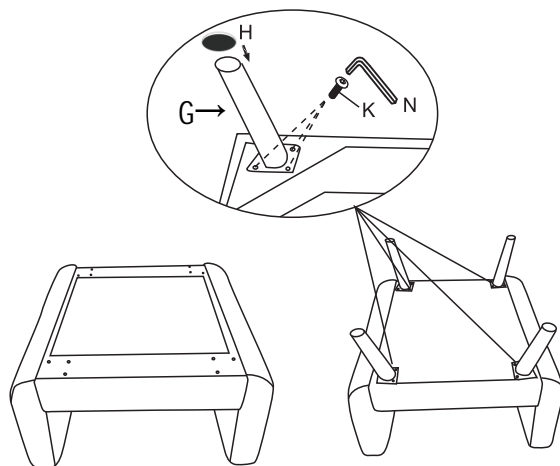

Attach part G to the bottom of the part A using parts K and N, paste part H to the bottom of the wooden leg

### STEP 5

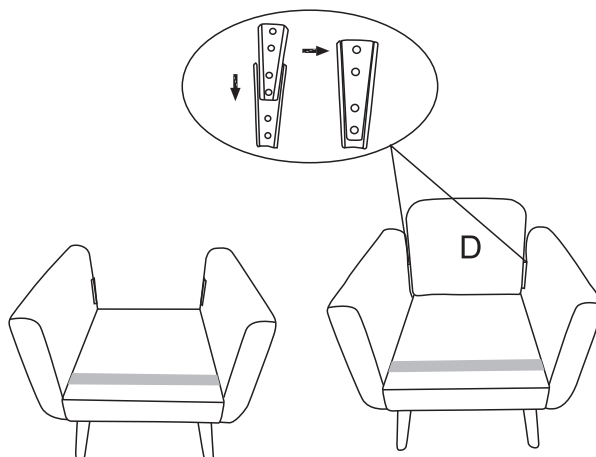

Insert part D, ensuring the parts align properly to make the connection.

### STEP 6

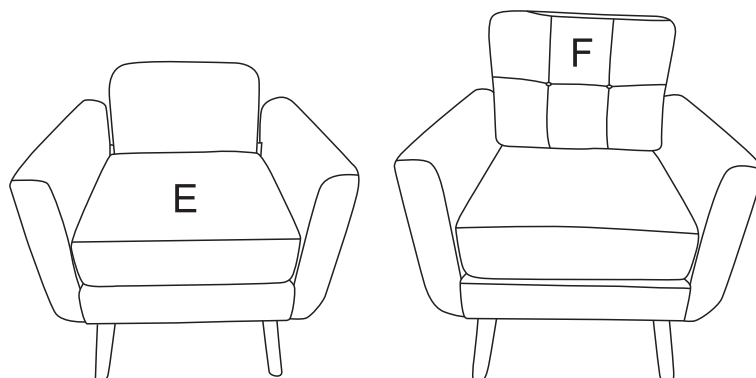

Place part E onto the seat and part F onto the backrest.  
(Note: After unpacking parts E and F, gently tap them and allow 48 hours for them to return to their pre-compressed state.)

# Frequently Asked Questions

We understand that receiving damaged or defective products can be disappointing, and we're here to assist you every step of the way. Here's how to address common concerns and initiate a damage claim:

## **1.What should I do if my shipment is damaged or products received are defective?**

We're genuinely sorry to hear about any inconvenience caused. Please reach out to us promptly, and our team will prioritize resolving the matter swiftly and effectively. To file a damage claim, follow these steps:

- A. Retain the original box in case a return is required.
- B. Take photos of the damaged box, the damaged part of the item, tracking number, and return label on the box to help us process a replacement or refund.

## **2.Can I return the product if I'm not satisfied?**

While we uphold stringent quality standards and collaborate with experienced manufacturers, we acknowledge that dissatisfaction may arise. If you're still unsatisfied, you can initiate a return within 30 days of receiving the product. Simply message us with your reasons for return, and we'll facilitate the process.