

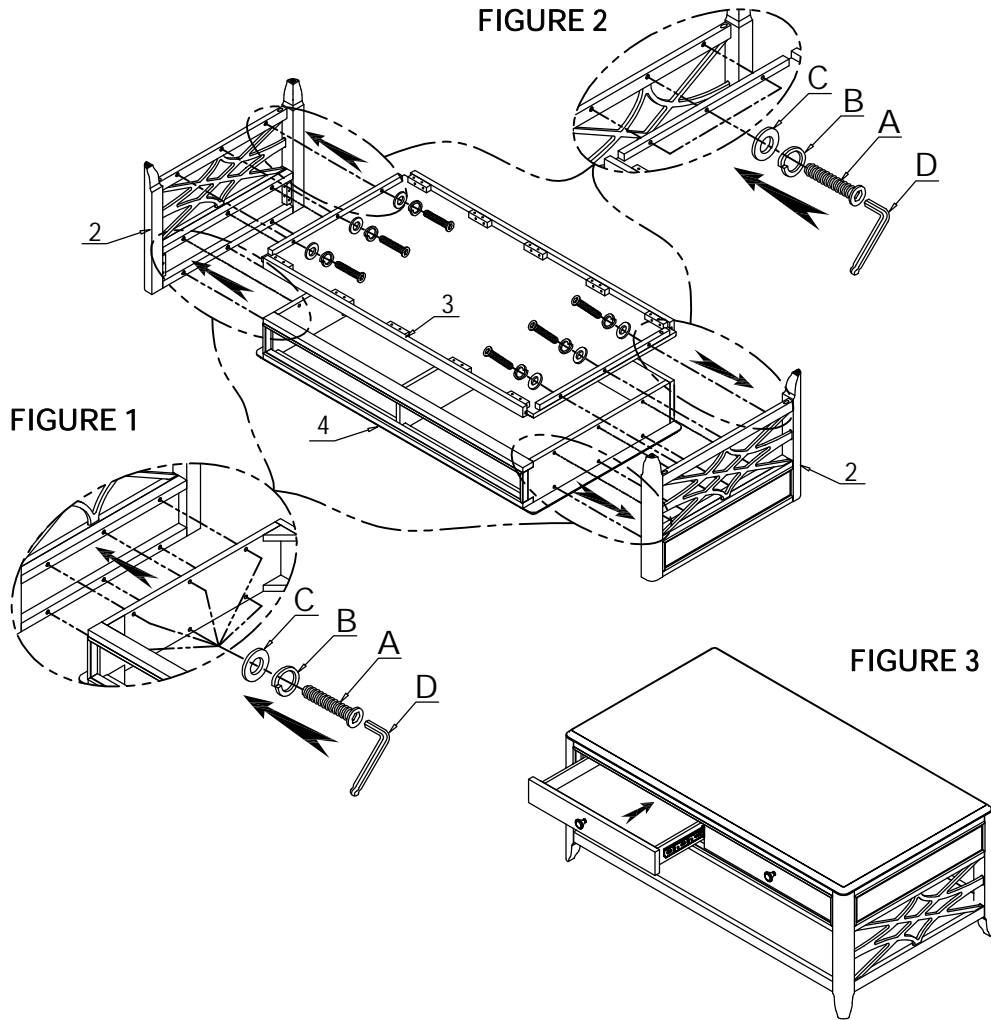

920-819 COFFEE FINISH-RECTANGLE DRAWER COCKTAIL TABLE



MADE IN VIETNAM

PARTS	MRP#	DESCRIPTION	Q'TY
A	1	BOLT ϕ 1/4"x1-3/8"	18
B		LOCK WASHER ϕ 1/4"	18
C		FLAT WASHER ϕ 1/4"x5/8"x5/64"	18
D		ALLEN KEY 4mm	1
2	2	SIDE FRAME	2
3	3	BOTTOM SHELF PANEL	1
4	4	TOP FRAME	1



920-819 COFFEE FINISH-RECTANGLE DRAWER COCKTAIL TABLE

WARNING! Failure to follow each of the following assembly instructions precisely may result in damage to the product and / or injury to consumer.

1. REMOVE ALL PARTS FROM CARTON AND SEPARATE THEM INTO PART NUMBER GROUPS AS INDICATED ON THE PART LIST. WHEN ORDERING ADDITIONAL PARTS, INDICATE MANUFACTURER REPLACEMENT PART NUMBER (MRP#) AS WELL AS PART NAME.

2. REMOVE THE DRAWER FROM THE DRAWER COCKTAIL TABLE, FOLLOWING THE BELOW STEPS:

- a. PULL THE DRAWER OUT UNTIL IT STOPS.
- b. IN THE MIDDLE OF THE GLIDES, WHERE EACH SECTION MEETS, THERE IS A PLASTIC TAB.
- c. PUSH DOWN ON THE PLASTIC TAB ON THE RIGHT AND PULL ON THE PLASTIC TAB ON THE LEFT.
- d. WHILE HOLDING THE TABS FULLY TO EACH SIDE, GENTLY PULL THE DRAWER OUT.

3. PLACE THE TOP FRAME UPSIDE DOWN ON A SMOOTH AND FLAT SURFACE. ATTACH SIDE FRAMES (2) TO THE TOP FRAME, SECURE WITH FLAT WASHERS (C), LOCK WASHER (B) AND BOLTS (A), USING ALLEN KEY (D). FOLLOWING FIGURE 1.

4. ATTACH BOTTOM SHELF PANEL (3) TO SIDE FRAMES, SECURE WITH FLAT WASHER (C), LOCK WASHER (B) AND BOLTS (A), USING ALLEN KEY (D). FOLLOWING FIGURE 2.

5. TURN THE ASSEMBLED RECTANGLE DRAWER COCKTAIL TABLE UPRIGHT NOW, RE-INSTALL THE DRAWER (5) FOLLOWING THE BELOW STEPS:

- a. PULL THE BALL BEARING GLIDE OUT UNTIL IT STOPS.
- b. ATTACH THE OUTSIDE GLIDE TO THE INSIDE GLIDE GENTLY, SLIGHTLY PUSH THE OUTSIDE GLIDE UNTIL HEAR "CLICKED".

ASSEMBLY IS NOW COMPLETE .

THANKS FOR YOUR PURCHASE !