

HEADBOARD SET ASSEMBLY INSTRUCTION (TOTAL 1 BOX)

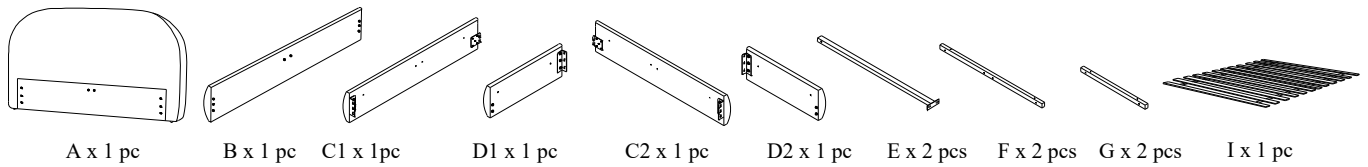

Please read over the instructions, it will be a time-saver in the long run.

Note: Before assembly, please be sure to work on a soft flat surface to avoid any damage to the finish.

Please leave bolts loosened until all bolts are placed before tightening completely.

Part#	Picture	Description	QTY	Location	Part#	Picture	Description	QTY	Location
H		Center leg	1	Embossed film wrap	Q		Spring Washer Ø8	16	Hardware Pack
J		Bolt Ø6x30mm	12	Already in Place				8	Already in Place
K		Bolt Ø8x30mm	8	Already in Place	R		Flat Washer Ø8x25mm	16	Hardware Pack
L		Bolt Ø8x60mm	12	Hardware Pack				8	Already in Place
M		Bolt Ø8x70mm	2	Hardware Pack	S		Spring Washer Ø6	12	Already in Place
N		"L" Wrenches Ø4	1	Hardware Pack	T		Flat Washer Ø6x25mm	12	Already in Place
O		"L" Wrenches Ø5	1	Hardware Pack	U		Spanner Ø14	1	Hardware Pack
P		Nut Ø8	2	Hardware Pack	V		Screws 4x30mm	24	Hardware Pack

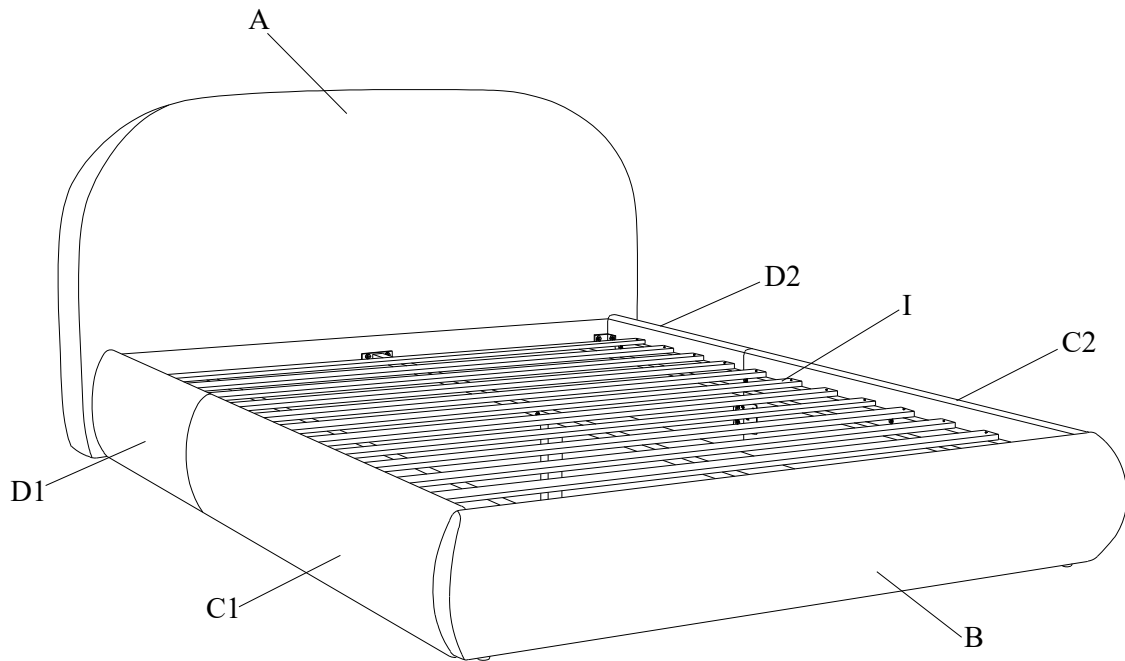

1

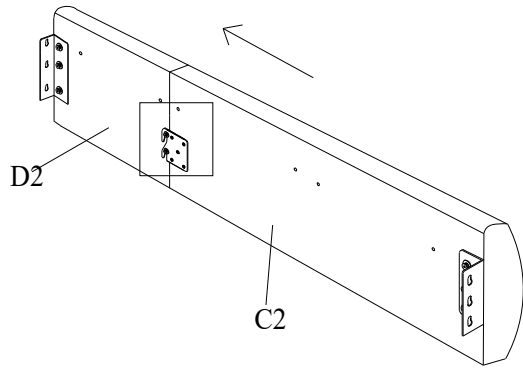

step1 → step2

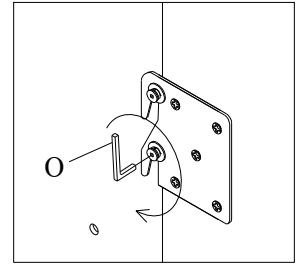
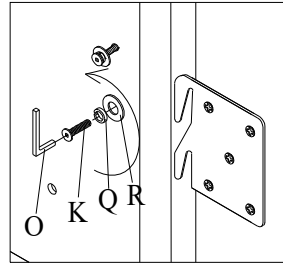

2

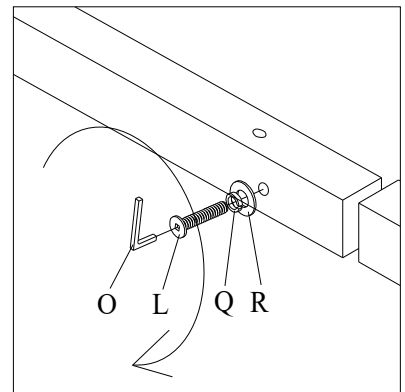
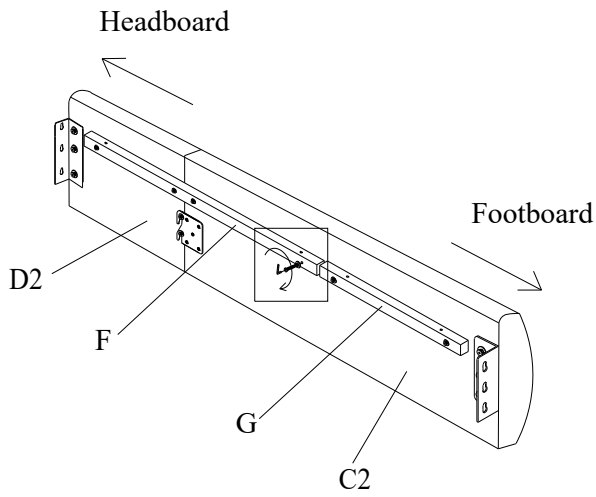

3

