

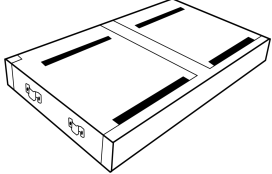

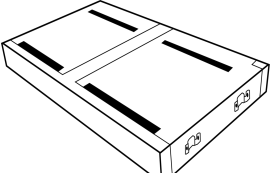
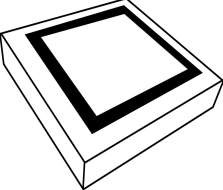
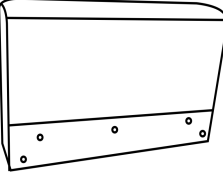
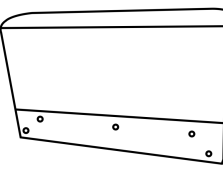
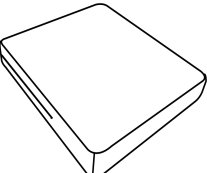
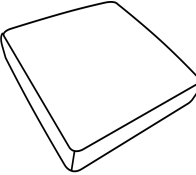
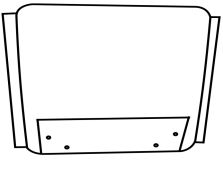
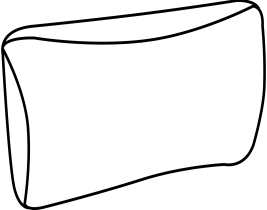
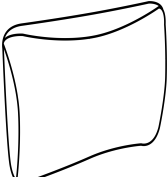

# Assembly Instruction

## Parts List

NO	Picture	Description	QTY
A	 A perspective drawing of a rectangular seat base with a central slot and two small rectangular cutouts on the front edge.	Left Seat Base	1PC
B	 A perspective drawing of a rectangular seat base, similar to part A but with a different internal slot configuration.	Right Seat Base	1PC
C	 A perspective drawing of a square ottoman seat base with a raised, beveled edge.	Ottoman Seat Base	2PCS
D	 A perspective drawing of a rectangular armrest with a curved top edge and three small circular holes along the bottom edge.	Right Arm	1PC
E	 A perspective drawing of a rectangular armrest, similar to part D but with a different top edge profile.	Left Arm	1PC
F	 A perspective drawing of a square seat cushion with a slightly raised edge.	Seat Cushion	4PCS
G	 A perspective drawing of a square seat cushion, similar to part F but with a different edge profile.	Seat Cushion	2PCS
J	 A perspective drawing of a rectangular seat backrest with a curved top edge and three small circular holes along the bottom edge.	Seat Back	4PCS

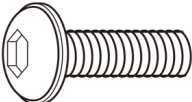
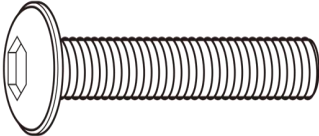
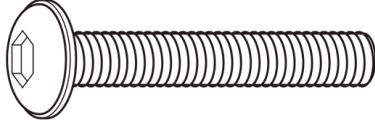
NO	Picture	Description	QTY
K		Back Cushion	4PCS
L		Pillow	2PCS
M		Legs	16PCS
H1		M6x18mm Screw	48PCS
H2		M8x35mm Screw	16PCS
H3		M8x40mm Screw	10PCS
H4		Φ22mm Washer	26PCS
H5		Φ18mm Washer	48PCS
H6		M5 Allen Wrench	1PC

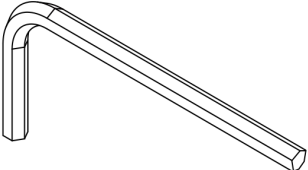
## Assembly Steps

### STEP 1

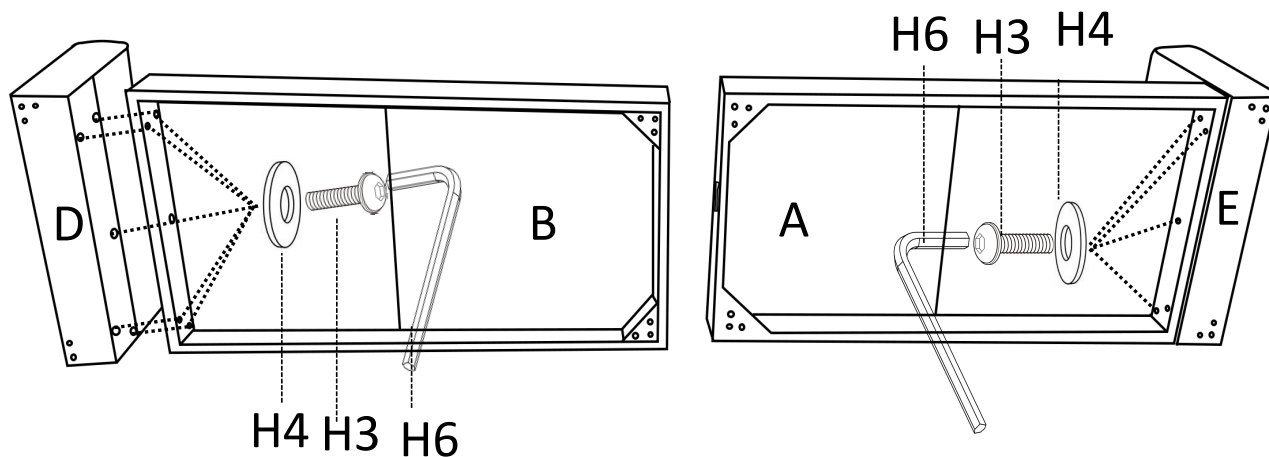

Attach the Arms (D&E) to the Seat Base(A&B) using (10) M8x40mm screws (H3) and (10)  $\Phi$ 22mm Washers (H4), tighten with the M5 Allen Wrench (H6).

### STEP 2

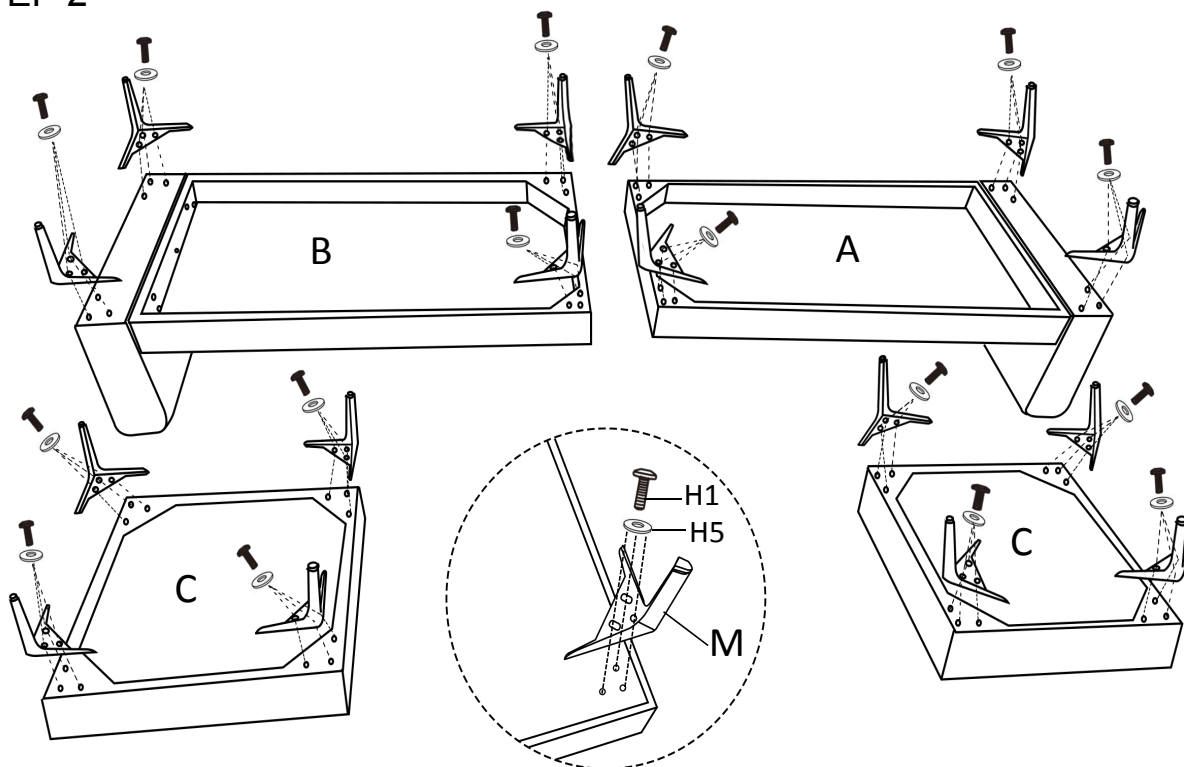

Attach the legs(M) to the Seat Base using (48) M6X18mm screws (H1) and (48)  $\Phi$ 18mm Washers (H5), tighten with the M5 Allen Wrench (H6) as shown.

### STEP 3

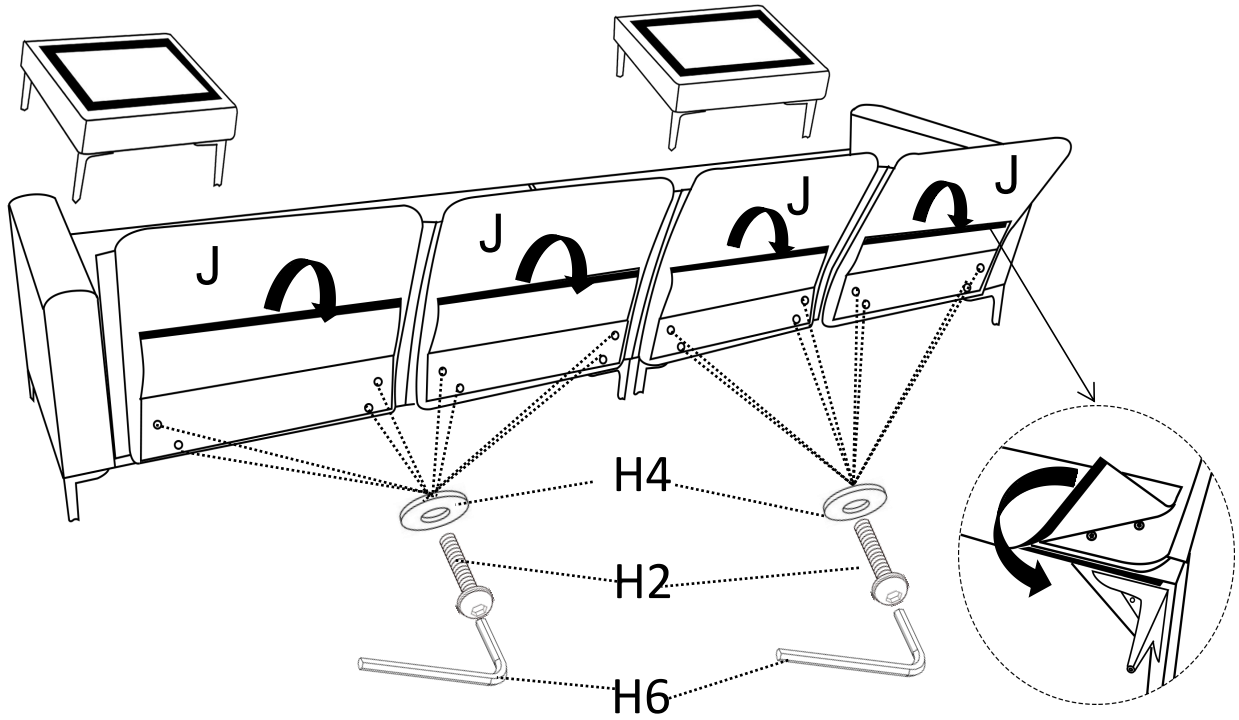

Attach the Seat Back to the Seat Base and align the holes to install the Seat Back, then put Velcro pieces together.

### STEP 4

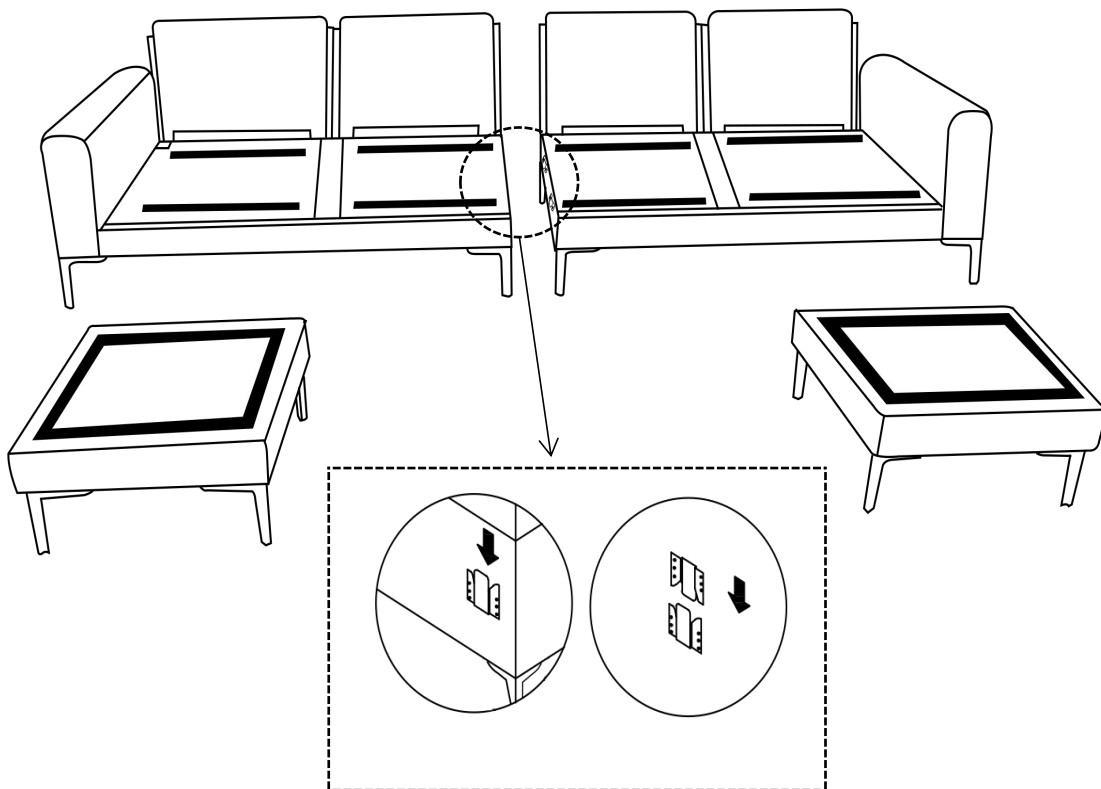

Connect the left seat base(A) to the right seat base(B) as shown.

STEP 5

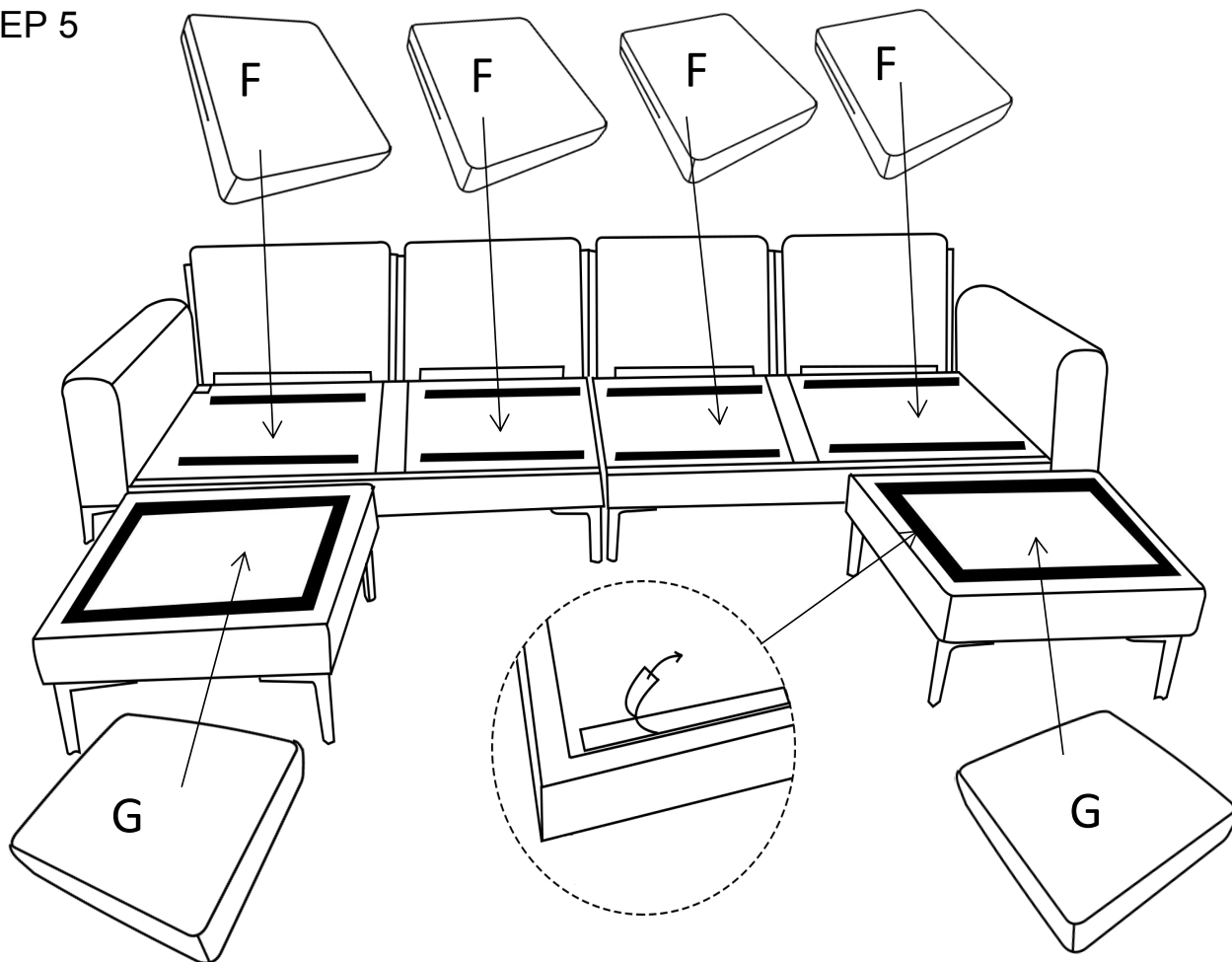

Tear off the Velcro protective cloth, then Attach the Seat Cushion into the Seat base as shown.

STEP 6

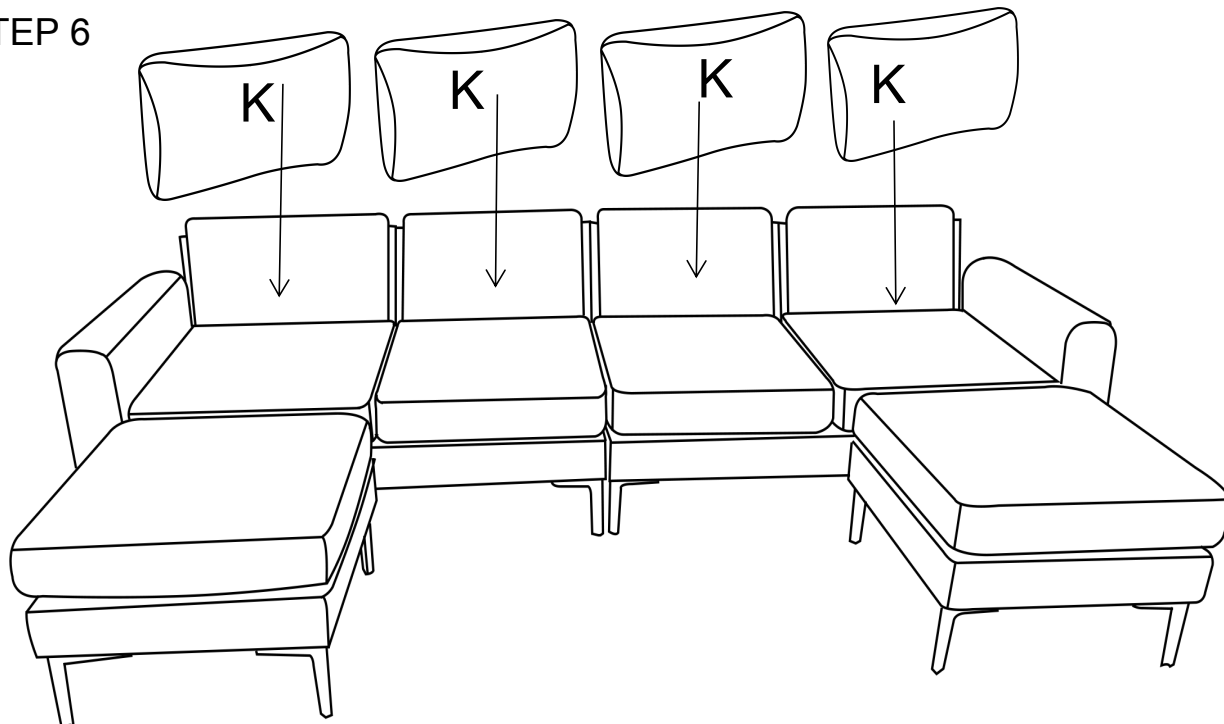

Lay the back cushion on the seat back as shown.

STEP 7

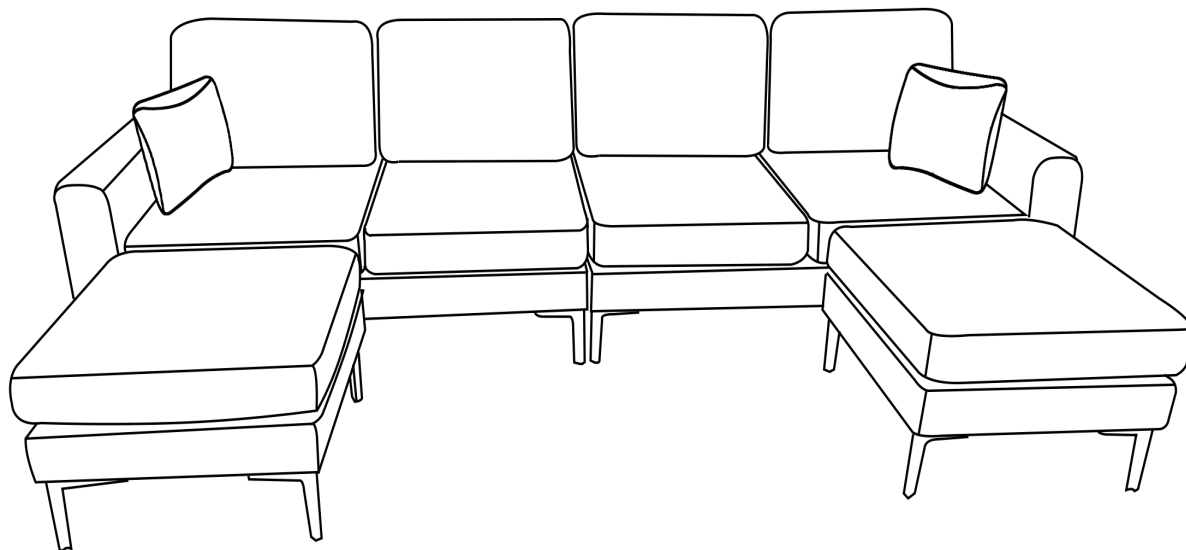

**FINISH!**