

5

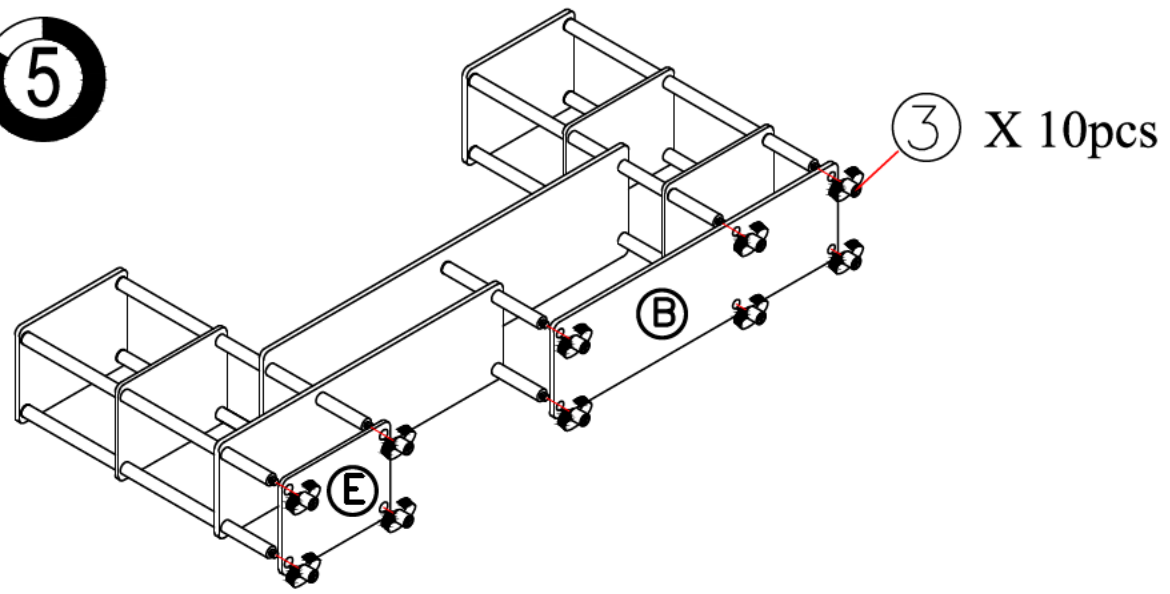

6

TURN 90°

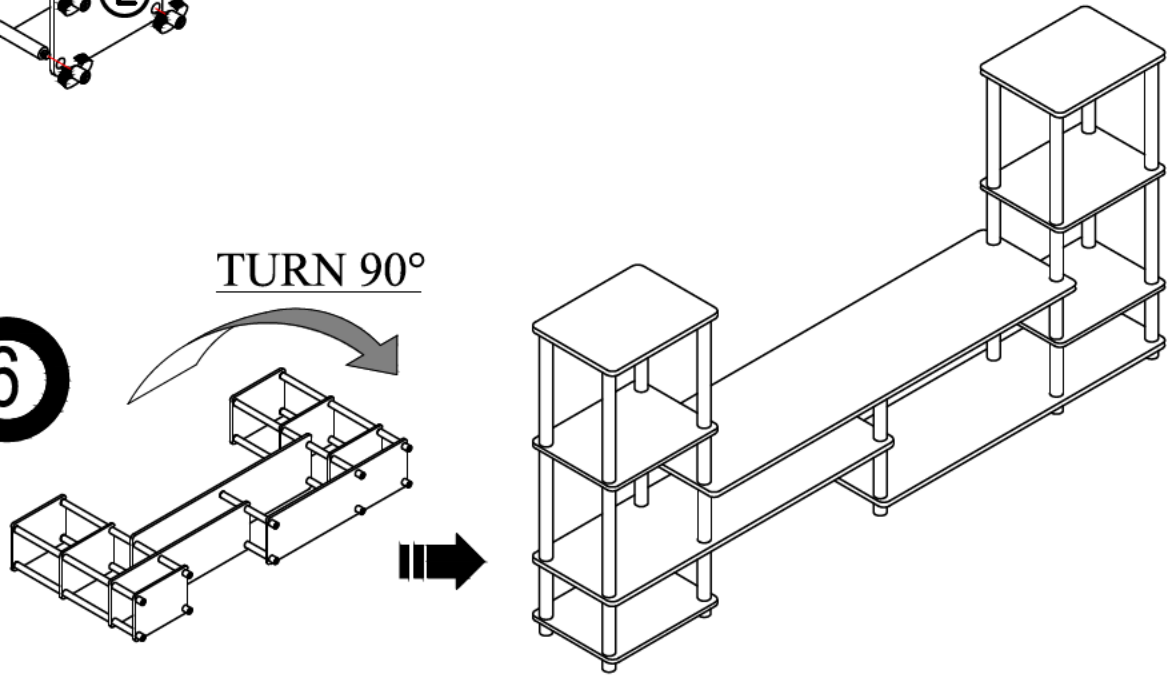

Recommended Maximum Weight

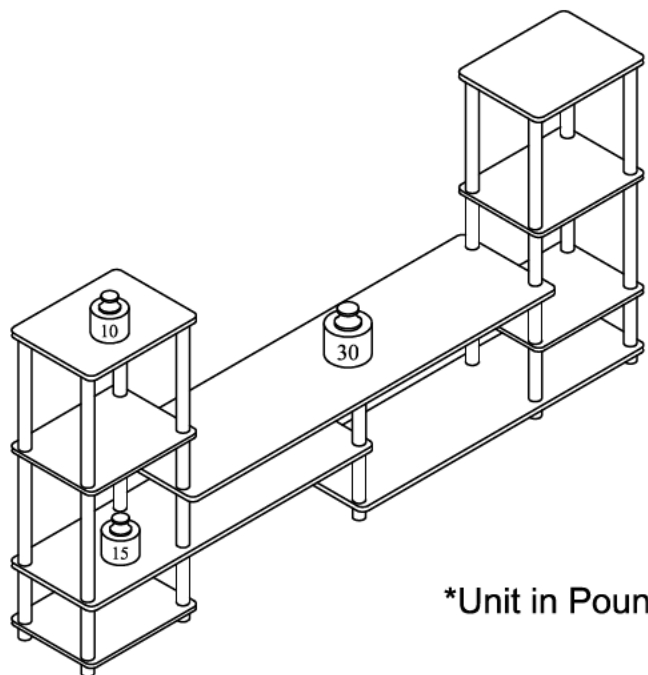

*Unit in Pound(lbs)

WARNING:

>This unit has been designed to support the maximum loads shown. Exceeding these load limits could cause sagging, instability, product collapse, and/or serious injury.

>DO NOT allow children to climb on unit.

> Put heavier items on lower shelves.

00:30

Approx. 30 minutes







Recomm. 2 Persons

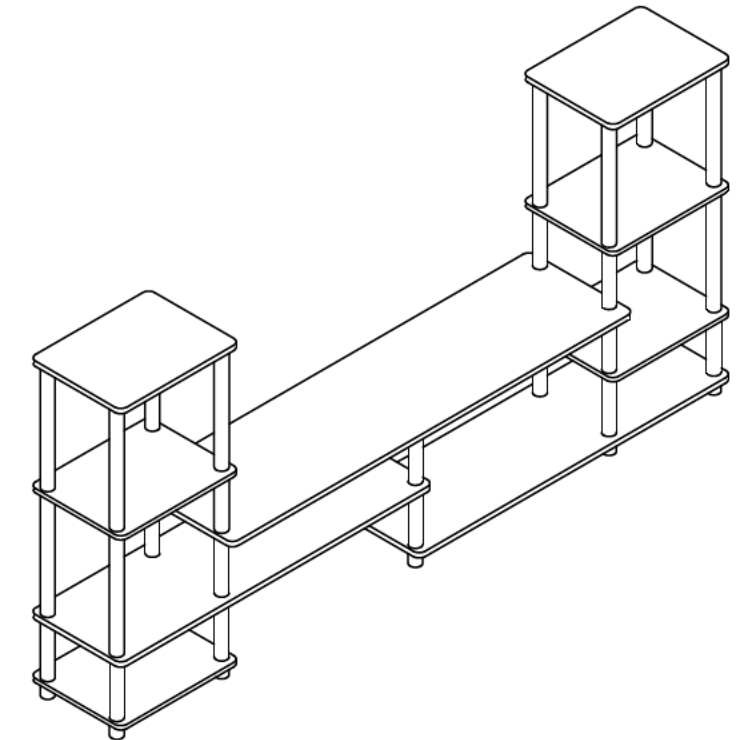

No Tools Required

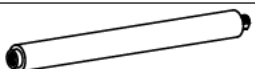
Assembly Instruction



NO	HARDWARE LIST	QTY
1	LONG POLE 	12pcs
2	SHORT POLE 	20pcs
3	LEG 	10pcs
4	ROUND RING 	4pcs

NO	PARTS LIST	QTY
A	CENTER TOP PANEL	1pc
B	LARGE SHELF PANEL	2pcs
C	SIDE TOP PANEL	2pcs
D	SECOND SHELF PANEL	2pcs
E	BOTTOM SMALL SHELF PANEL	2pcs

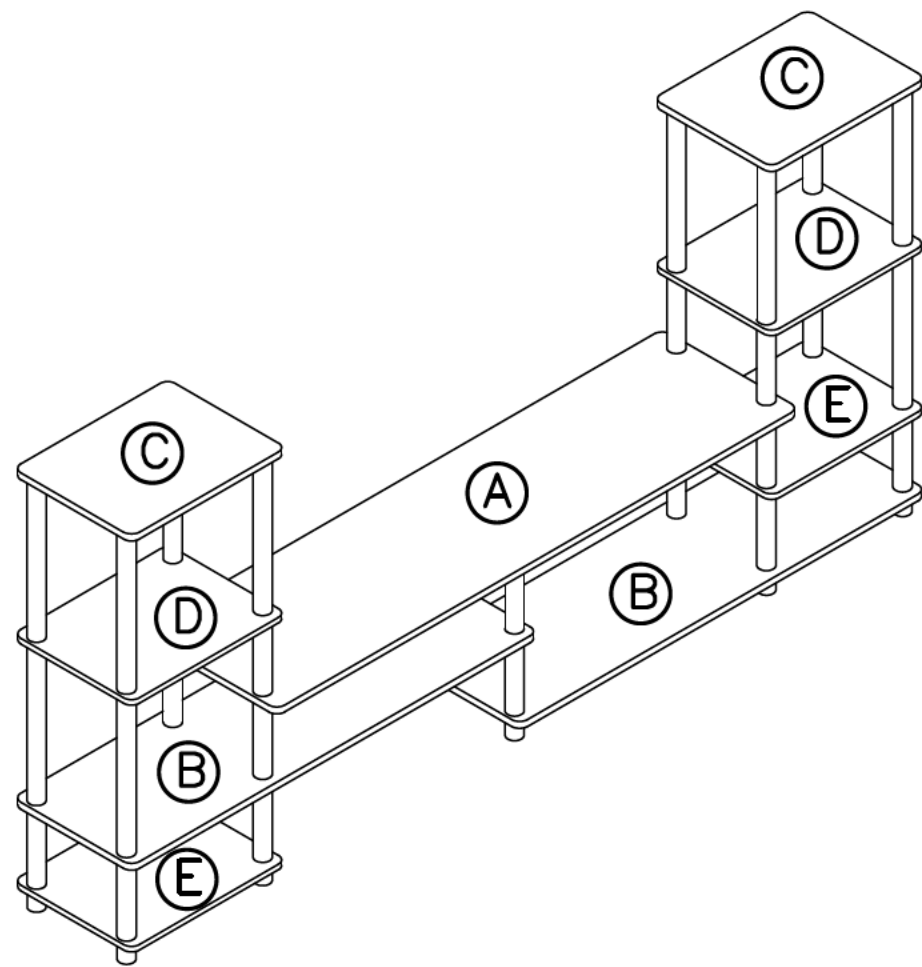

USEFUL HINTS BEFORE YOU START:

1. Read each step carefully before starting.
2. It is important that each step is performed in correct order to avoid difficulties.
3. Identify, sort and count the parts before assembly.
4. Assemble your furniture on packaging cardboard to prevent scratch or damage.
5. Clean the product with mild cleanser using soft damped cloth. Do not use harsh or abrasive cleanser.
6. Using incompatible hardware might cause damage to product.

ASSEMBLY INSTRUCTION

