





ASSEMBLY INSTRUCTIONS

1270025

HARDWARE

<p>Ax12</p>  <p>M6 x 35 mm</p>	<p>Bx12</p>  <p>Ø17 x 1.5 mm</p>	<p>Cx12</p>  <p>Ø13 x 1.5 mm</p>	<p>Dx1</p>  <p>4 mm</p>
---	---	--	--

PARTS

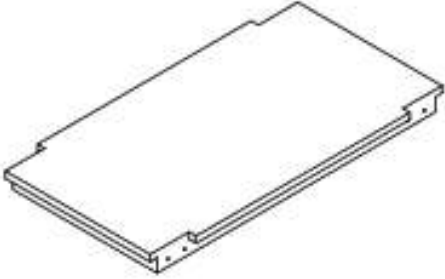
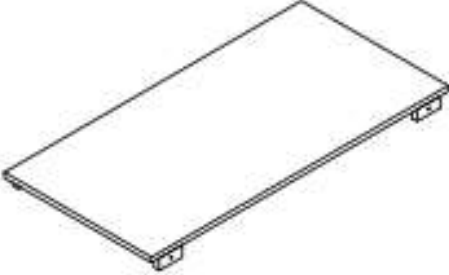
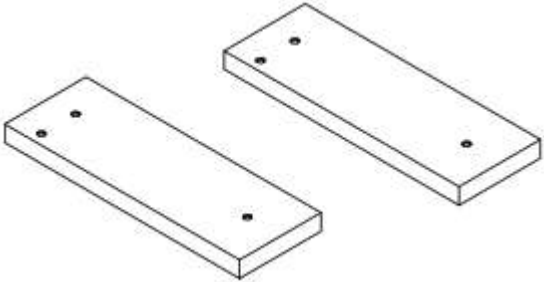
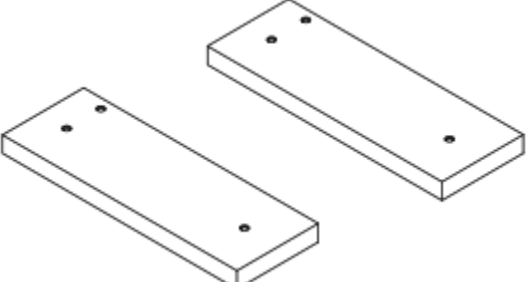
<p>1x1</p> 	<p>2x1</p> 
<p>3x2</p> 	<p>4x2</p> 

(1)

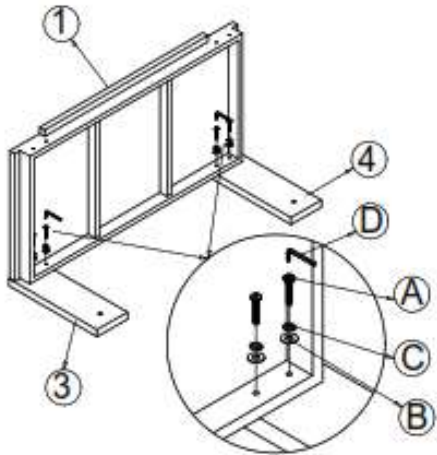

- Place the Top (1) and Legs (3,4) in the Position shown in the image above. Align the bolt holes of the Top (1) with those of the Legs (3,4).
- Begin by assembling the left leg (3): Insert bolt (A), a flat washer (B) and a spring washer (C) into the Top's (1) bolt hole, then tighten with an Allen key (D). Repeat this process for the right leg (4).

(2)

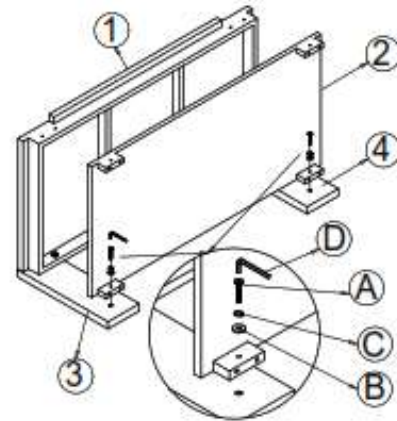

- Place the shelf (2) in the position shown in the image above. Align the bolt holes of the shelf (2) with those of the legs (3,4).
- Insert bolts (A), Flat Washer (B) and Spring washer (C) into the shelf's (2) bolt hole, then tighten with an Allen key (D). Repeat this for both the left (3) and right (4) legs.

(3)

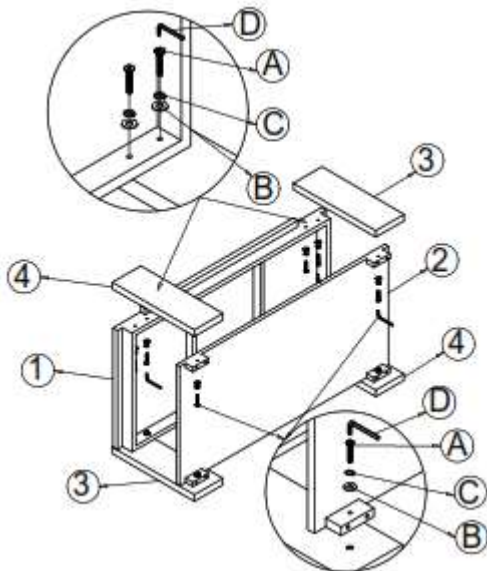

- Place the remaining legs (3,4) in the position shown in the image above. Align the bolt holes of the top (1) and the shelf (2) with those of the legs (3,4).
- Repeat the process of tightening the bolts as shown in steps 1 and 2.

(4)

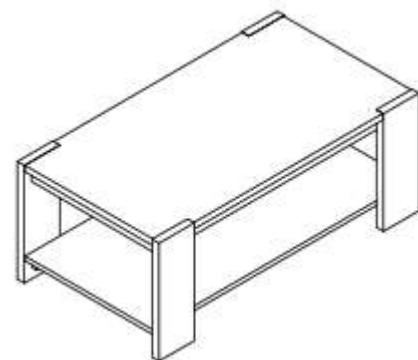

- Make sure everything is securely installed.
- The product is ready to use.
- Completed