

Assembly Instructions

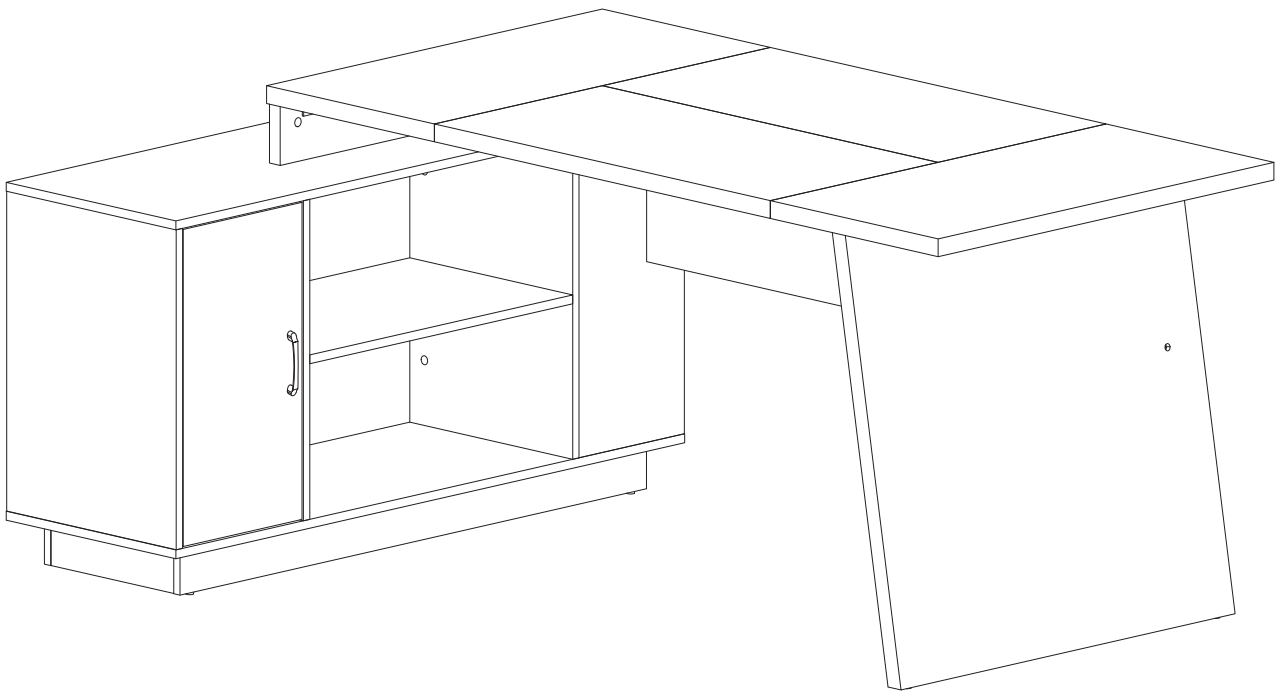

Office Table

Contact Us

We're here to help you.

Your satisfaction is our top priority. If you encounter any issues with this product, such as missing or damaged parts, we're here to help. Please retain the original packaging and take photos of the packaging and the product, then contact us as soon as possible.

Warm Tips

1. Carefully read these instructions and keep them for future reference.
2. Check the parts list and confirm everything's there before starting assembly.
3. When assembling, put all parts on a soft, smooth surface like a carpet to avoid scratches.
4. Don't fully tighten screws until all parts are confirmed in place to avoid misalignment.

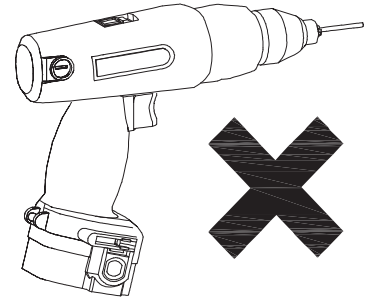
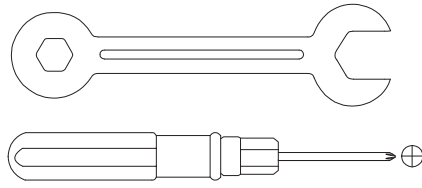
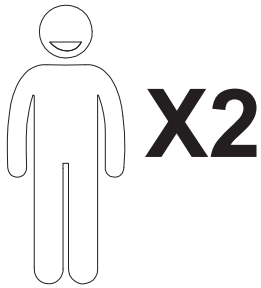

We recommend using hand tools for assembly.

If an electric screwdriver is used, reduce power and torque to avoid damage to the product.

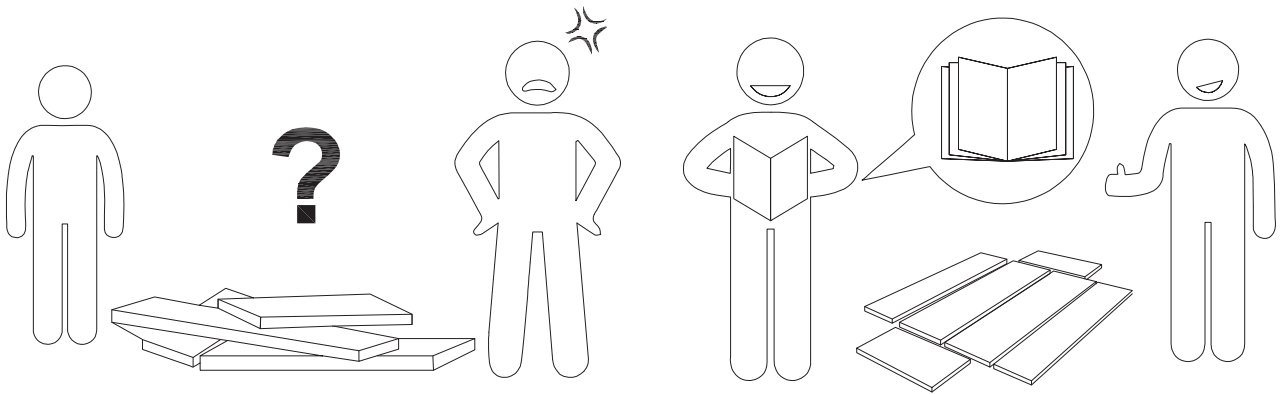

AVOID SCRATCHES

In order to avoid scratching, this furniture should be assembled on a soft surface, such as a rug.

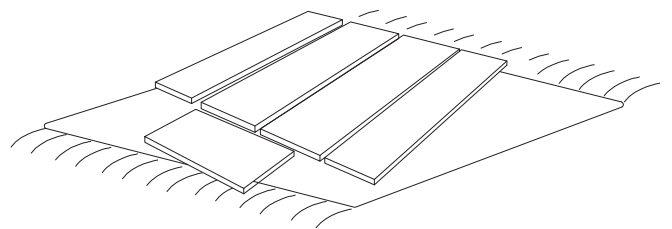
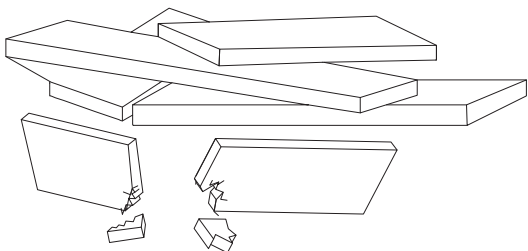

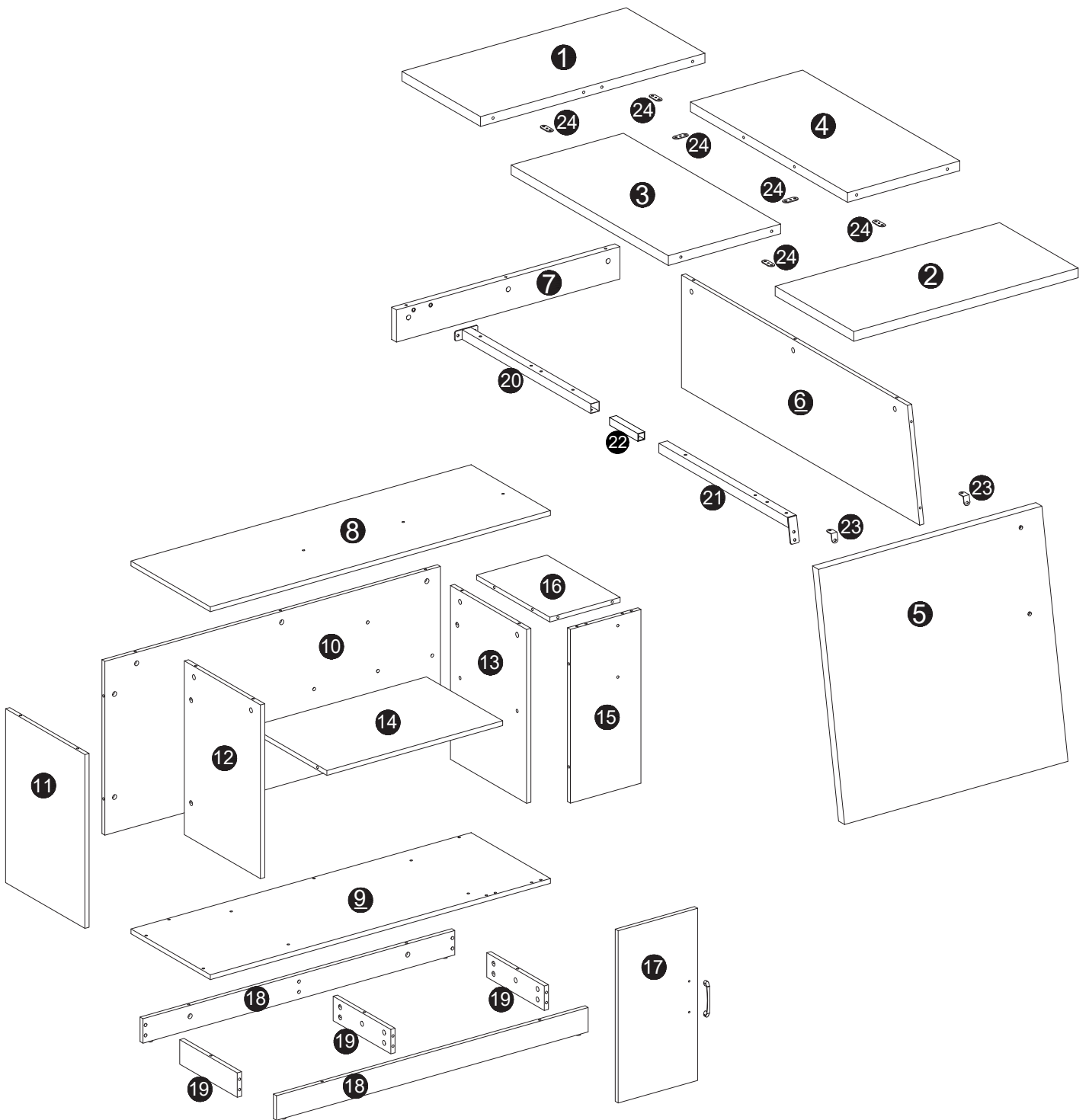



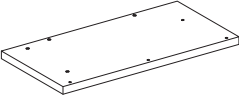
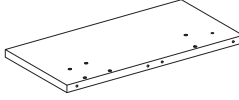
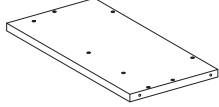
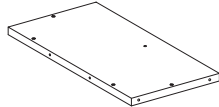
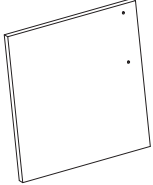
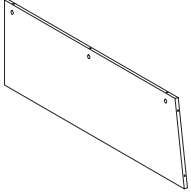
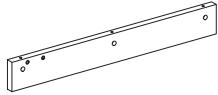
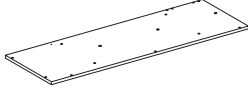
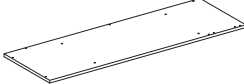
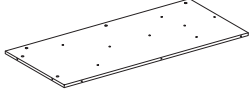
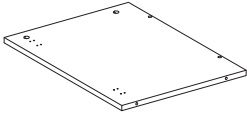
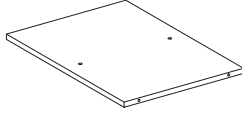
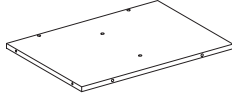
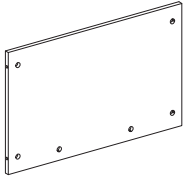
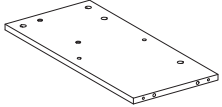
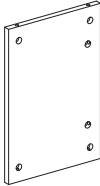
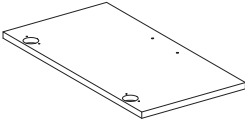
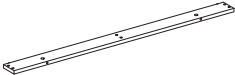

⚠ Caution

Make sure all parts are included. Most board parts are labeled or stamped on the raw edge. Contact us for a free replacement if you encounter any damaged or missing parts.

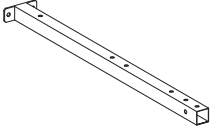
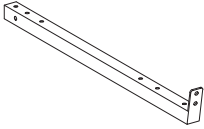
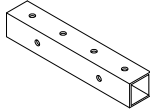
Parts List

<p>①</p>  <p>1pc</p>	<p>②</p>  <p>1pc</p>	<p>③</p>  <p>1pc</p>	<p>④</p>  <p>1pc</p>	<p>⑤</p>  <p>1pc</p>
<p>⑥</p>  <p>1pc</p>	<p>⑦</p>  <p>1pc</p>	<p>⑧</p>  <p>1pc</p>	<p>⑨</p>  <p>1pc</p>	<p>⑩</p>  <p>1pc</p>
<p>⑪</p>  <p>1pc</p>	<p>⑫</p>  <p>1pc</p>	<p>⑬</p>  <p>1pc</p>	<p>⑭</p>  <p>1pc</p>	<p>⑮</p>  <p>1pc</p>
<p>⑯</p>  <p>1pc</p>	<p>⑰</p>  <p>1pc</p>	<p>⑱</p>  <p>2 pcs</p>	<p>⑲</p>  <p>3 pcs</p>	<p>⑳</p>  <p>1pc</p>
<p>㉑</p>  <p>1pc</p>	<p>㉒</p>  <p>1pc</p>	<p>㉓</p>  <p>2 pcs</p>	<p>㉔</p>  <p>6 pcs</p>	

Before installation, please check if you have received the A, B packages, and check if the parts are complete.

①	1 pc
②	1 pc
③	1 pc
④	1 pc
⑤	1 pc

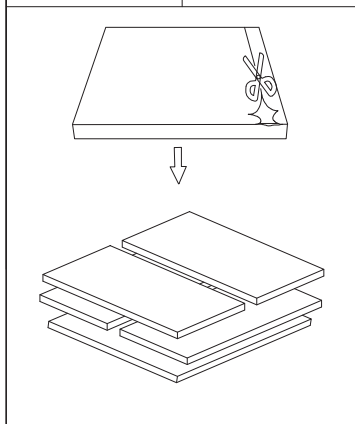

⑥	1 pc
⑩	1 pc
⑭	1 pc
⑱	2 pcs
⑳	1 pc



⑦	1 pc
⑪	1 pc
⑮	1 pc
⑲	3 pcs
㉓	2 pcs



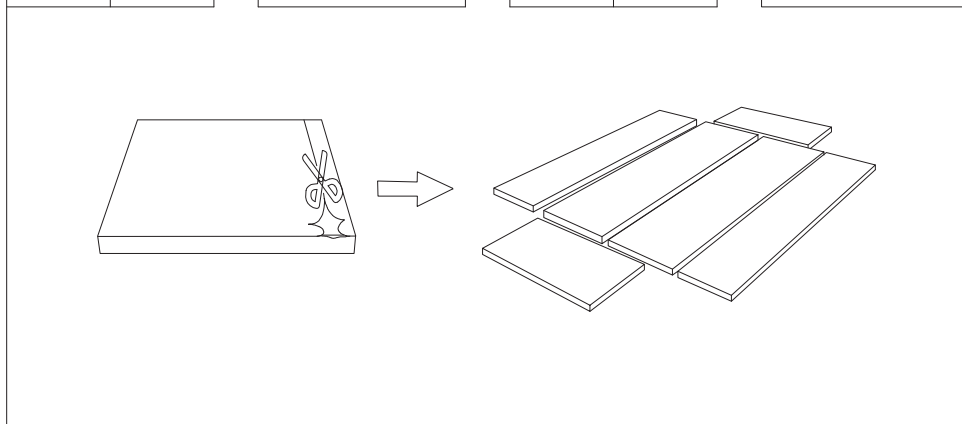

⑧	1 pc
⑫	1 pc
⑯	1 pc
㉔	1 pc
㉕	6 pcs

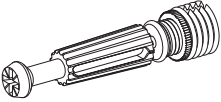
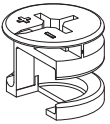

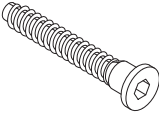
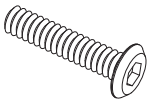

⑨	1 pc
⑬	1 pc
⑰	1 pc
㉖	1 pc

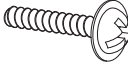

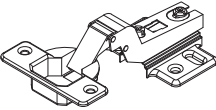
Hardware List

A	B	C	D	E
 <p data-bbox="150 510 323 544">Ø6x40mm</p>	 <p data-bbox="432 510 627 544">Ø15x12mm</p>	 <p data-bbox="715 510 887 544">Ø8x30mm</p>	 <p data-bbox="991 510 1166 544">Ø7x47mm</p>	 <p data-bbox="1278 510 1453 544">M6x40mm</p>
57 pcs	57 pcs	15 pcs	19 pcs	9 pcs

F	G	H	I	J
 <p data-bbox="150 994 323 1028">M6x12mm</p>	 <p data-bbox="387 994 627 1028">125x12x20mm</p>	 <p data-bbox="715 994 887 1028">M4x18mm</p>	 <p data-bbox="991 994 1166 1028">Ø20x8mm</p>	
27 pcs	1 pc	2 pcs	1 pc	2 pcs

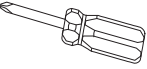
K	L	M	N	O
 <p data-bbox="134 1476 344 1509">Ø3.5x14mm</p>	 <p data-bbox="432 1476 568 1509">Ø20mm</p>	 <p data-bbox="715 1476 850 1509">Ø20mm</p>	 <p data-bbox="991 1476 1166 1509">M4x65mm</p>	
14 pcs	27 pcs	14 pcs	1 pc	1 pc

Installation of Cams and Pins

Step 1-2: Align the plastic part with the mounting hole and press it in. If you can't press it in, loosen the screw counter clockwise or completely remove the screw from the plastic part and try again.

Step 3-4: After pressing the plastic part into place, use a screwdriver to tighten the screw clockwise.

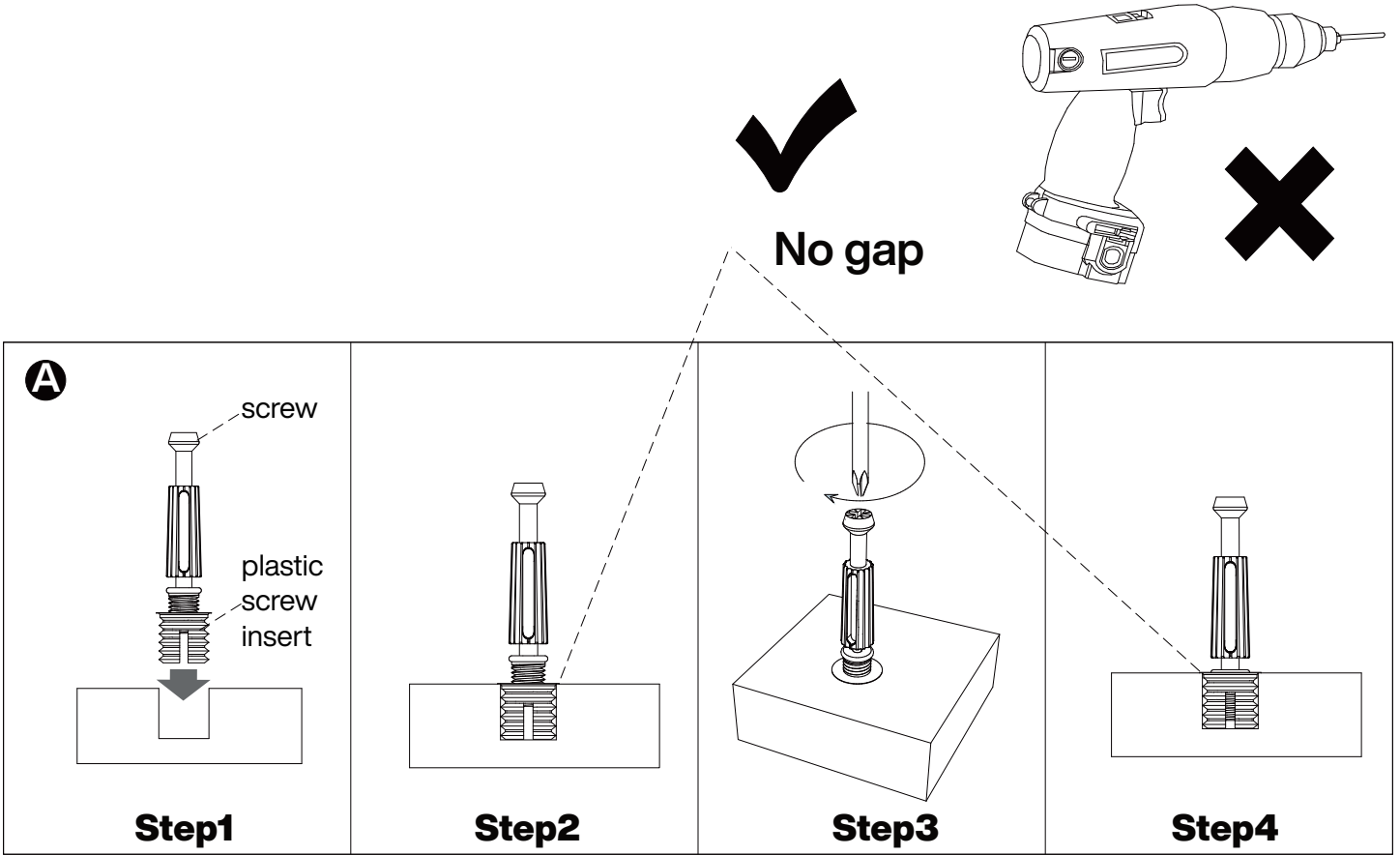

Screw the pin into the hole. Set the cams correctly by aligning the head of the cams with the lock pins. Lock the cam by turning the cam head with a screwdriver until it is tightened. Please do not use an electric screwdriver to assemble the unit.

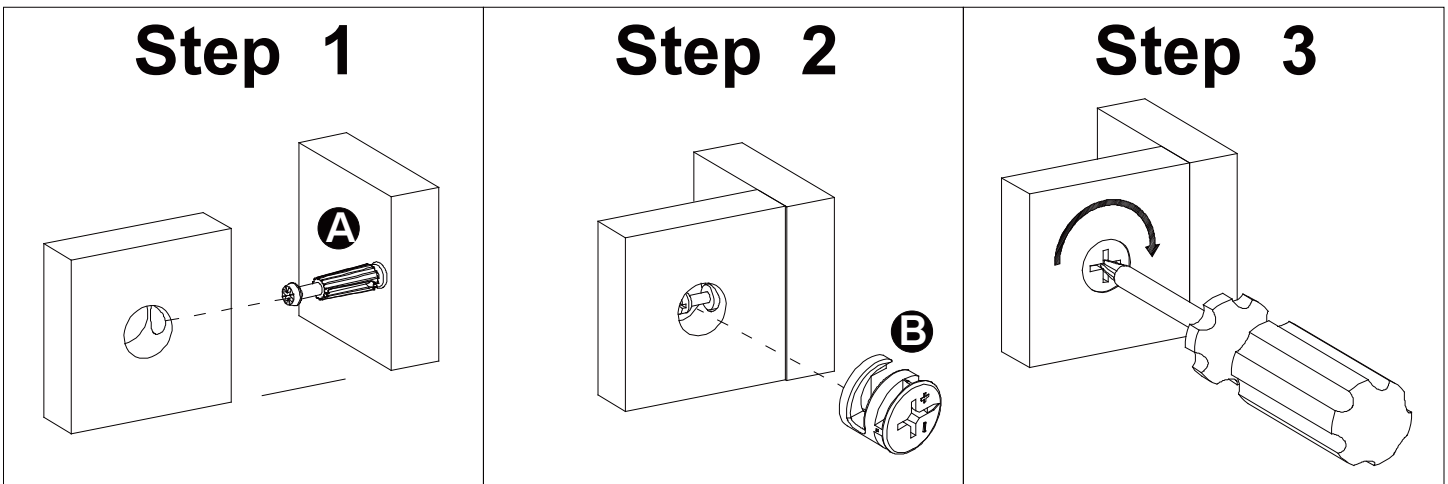

1

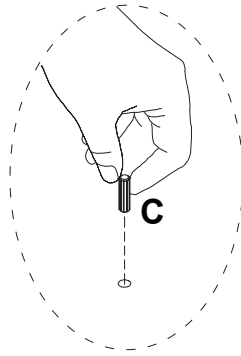

C

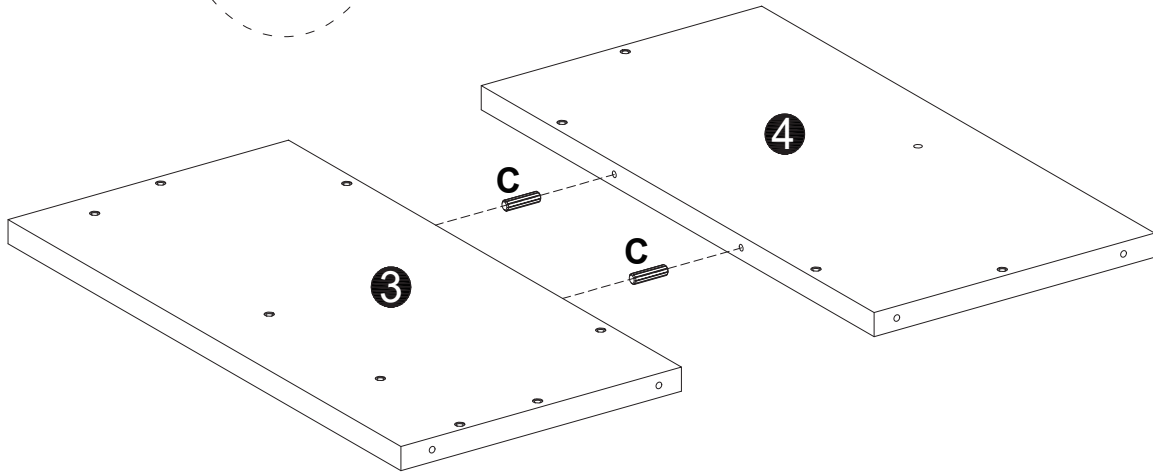
Ø8x30mm
2 pcs



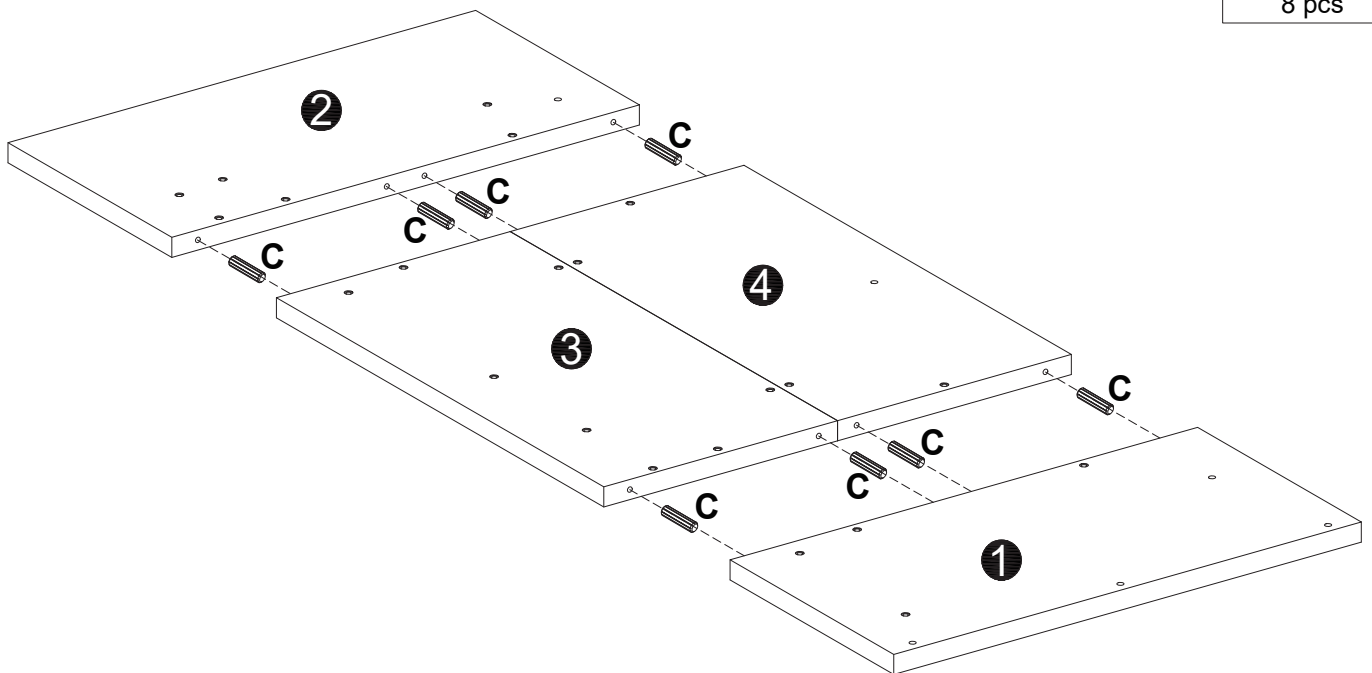

2

C

Ø8x30mm
8 pcs

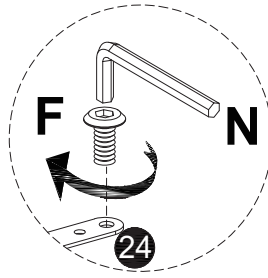

3

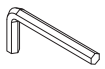

F	N
	
M6x12mm	M4x65mm
12 pcs	1 pc

screw down 

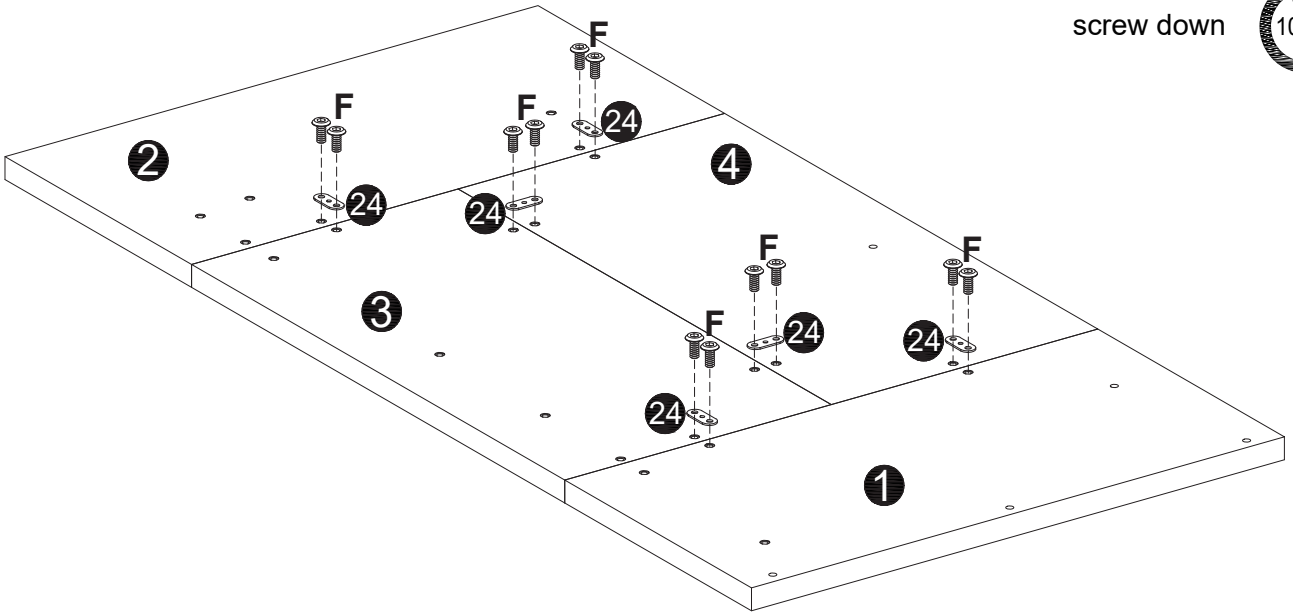

4

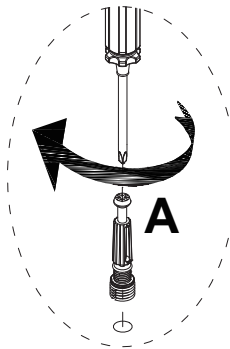
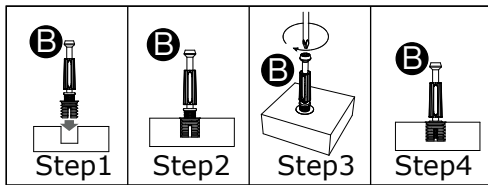

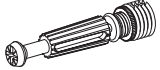

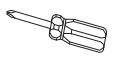
A

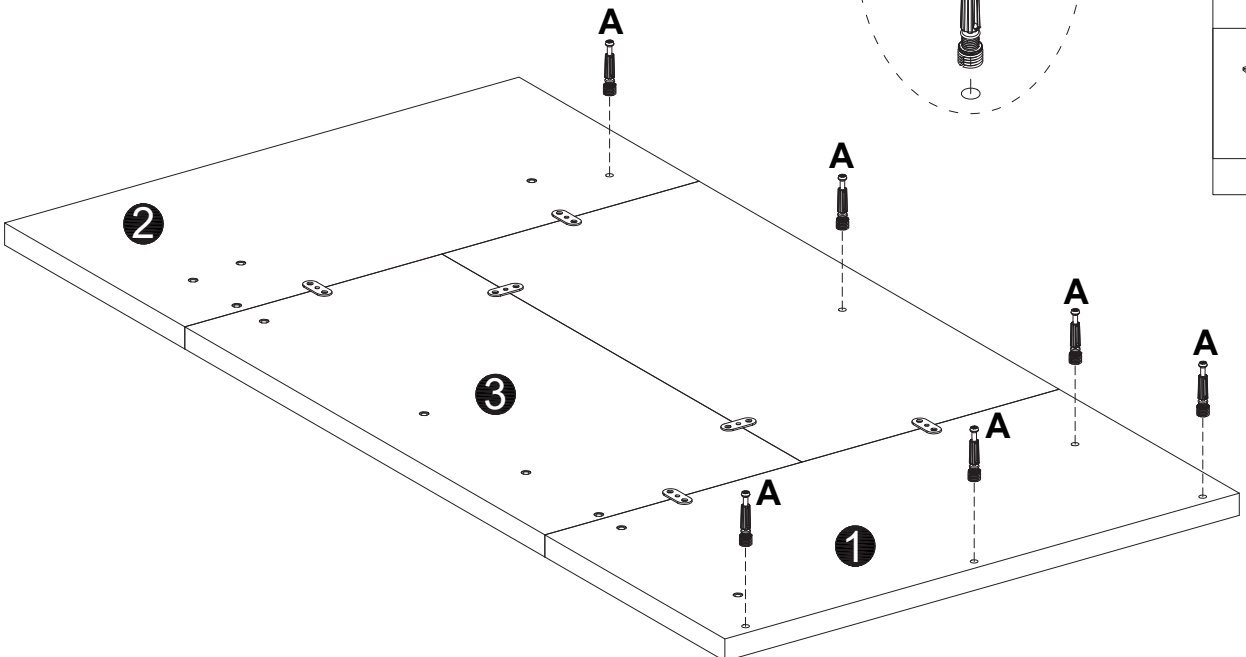
Ø6x40mm
6 pcs

O

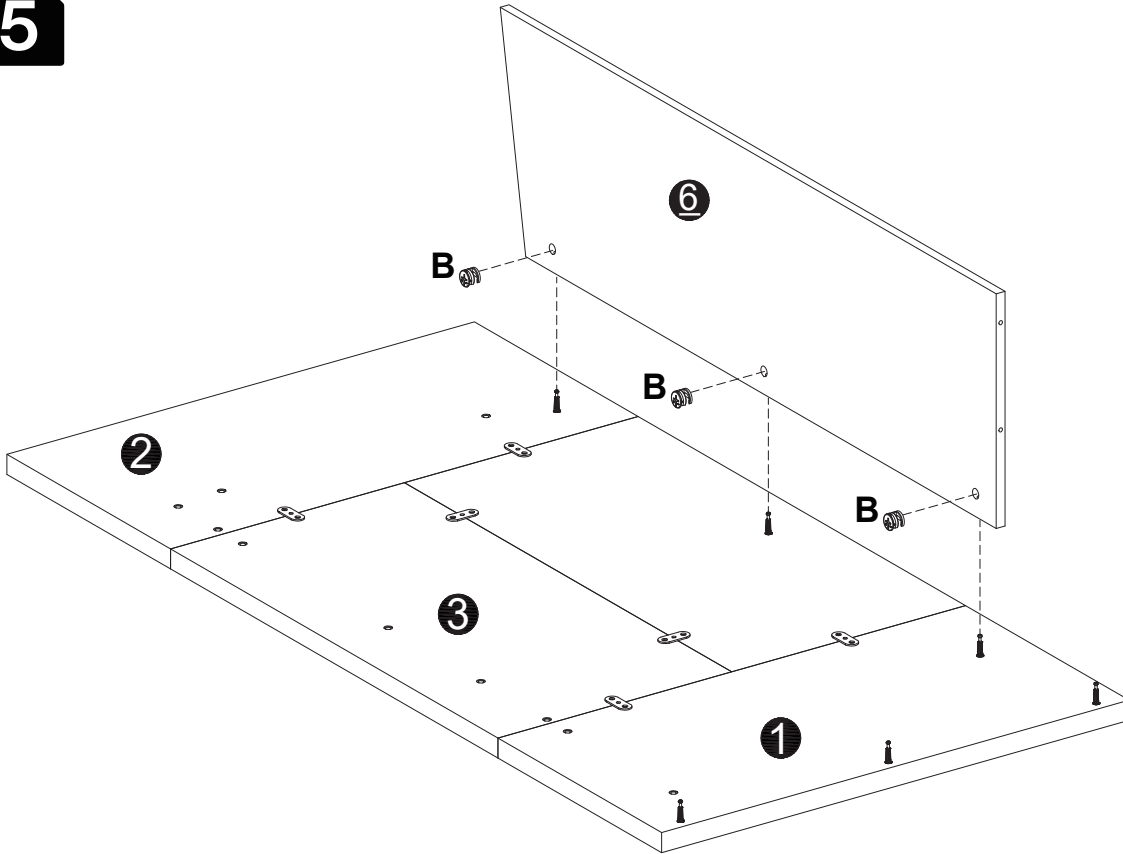
1 pc



5



B

Ø15x12mm
3 pcs

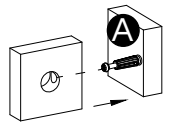
Step 1

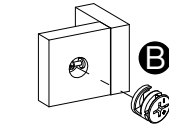

Step 2



Step 3

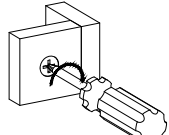

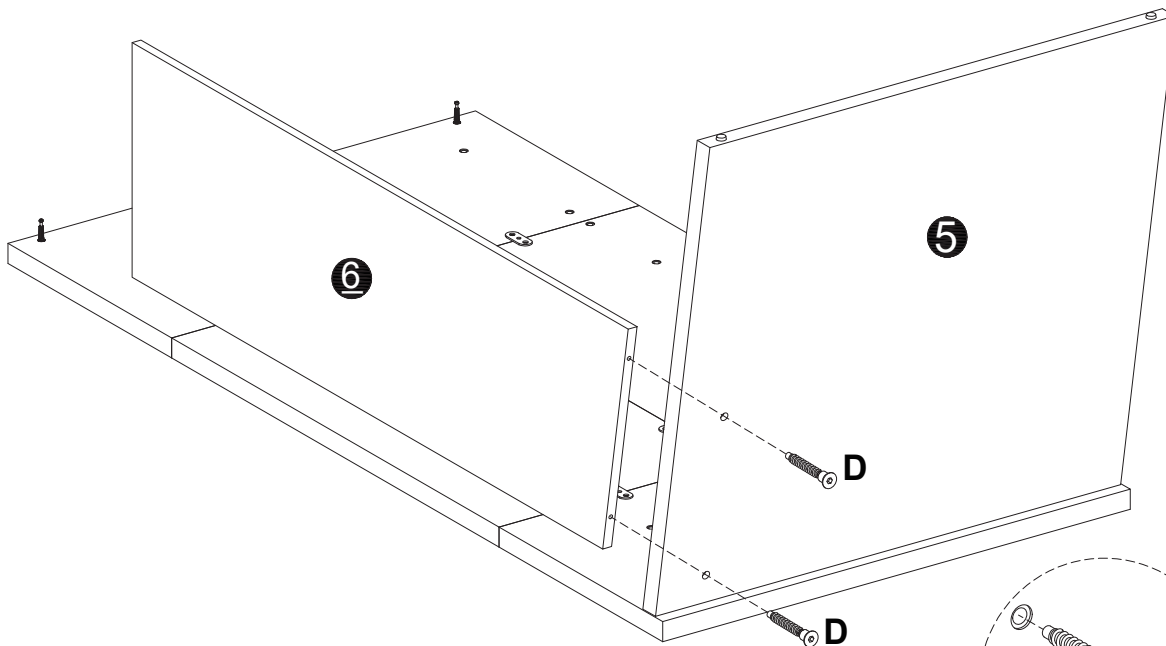

6

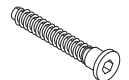

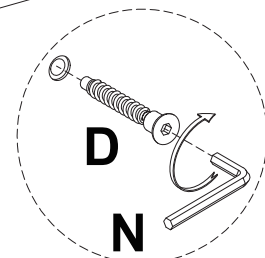
D

Ø7x47mm
2 pcs

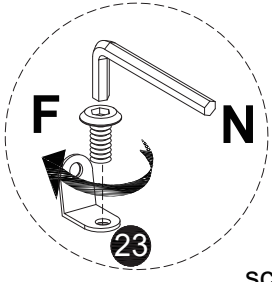
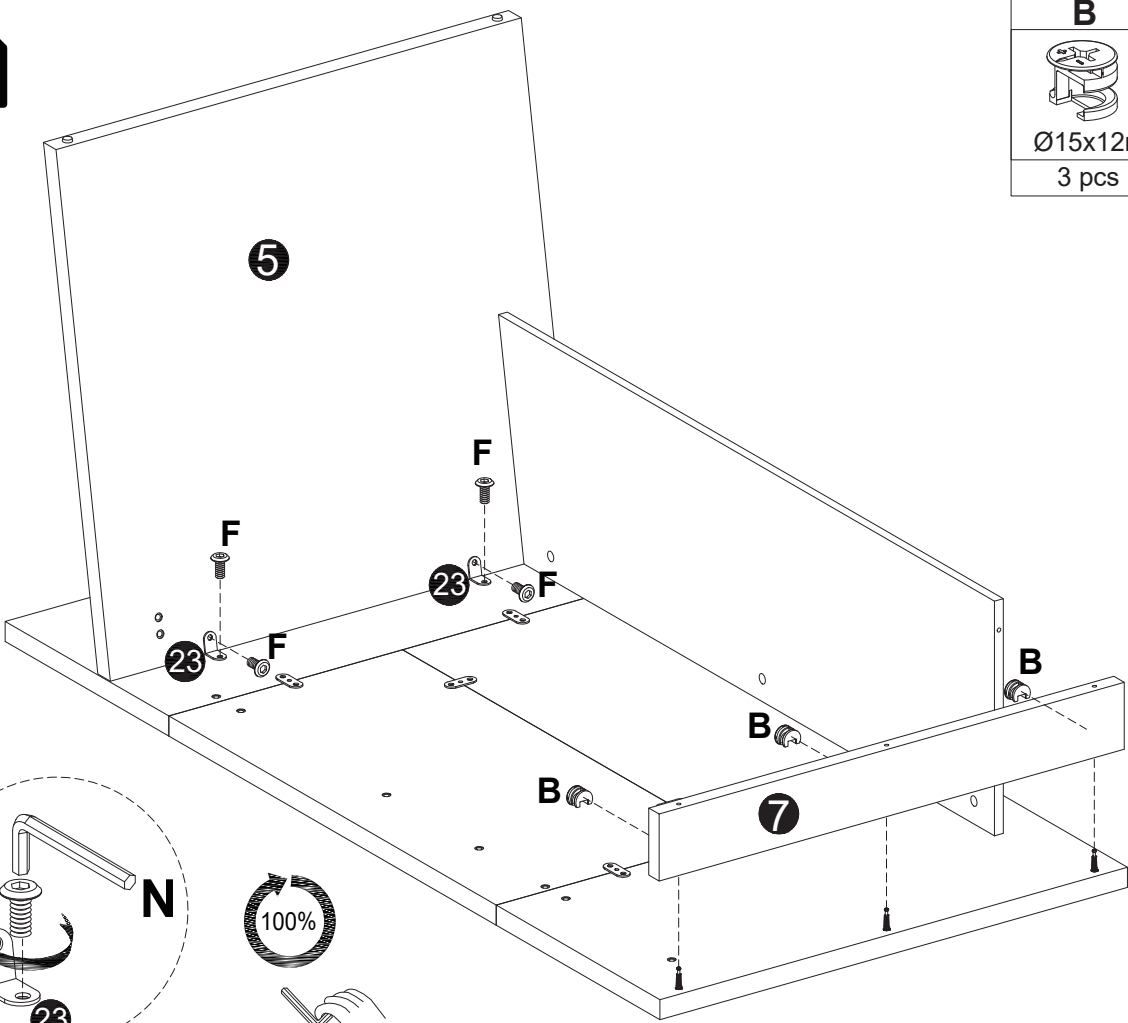

7

B	F
	
Ø15x12mm	M6x12mm
3 pcs	4 pcs



screw down

8

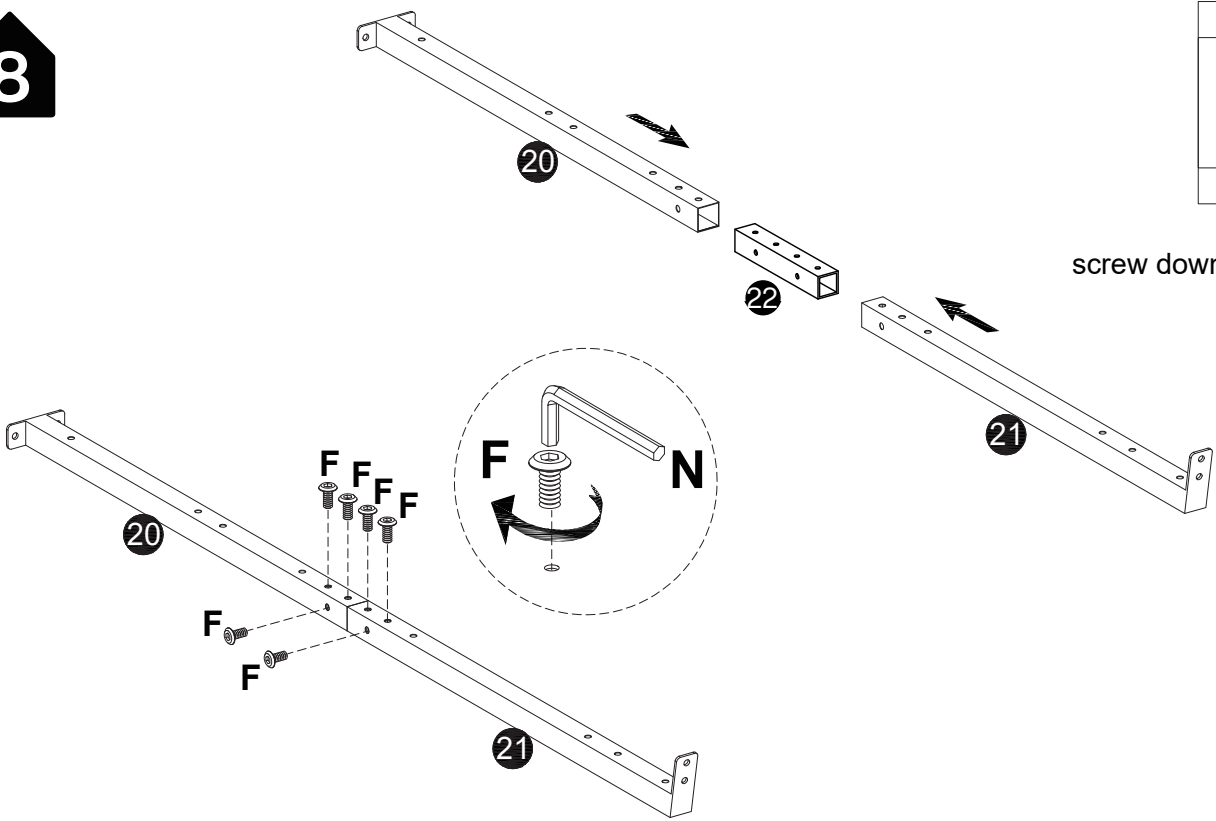

F

M6x12mm
6 pcs

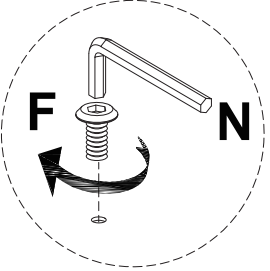

screw down

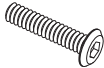

9

E	F
	
M6x40mm	M6x12mm
8 pcs	4 pcs

screw down 

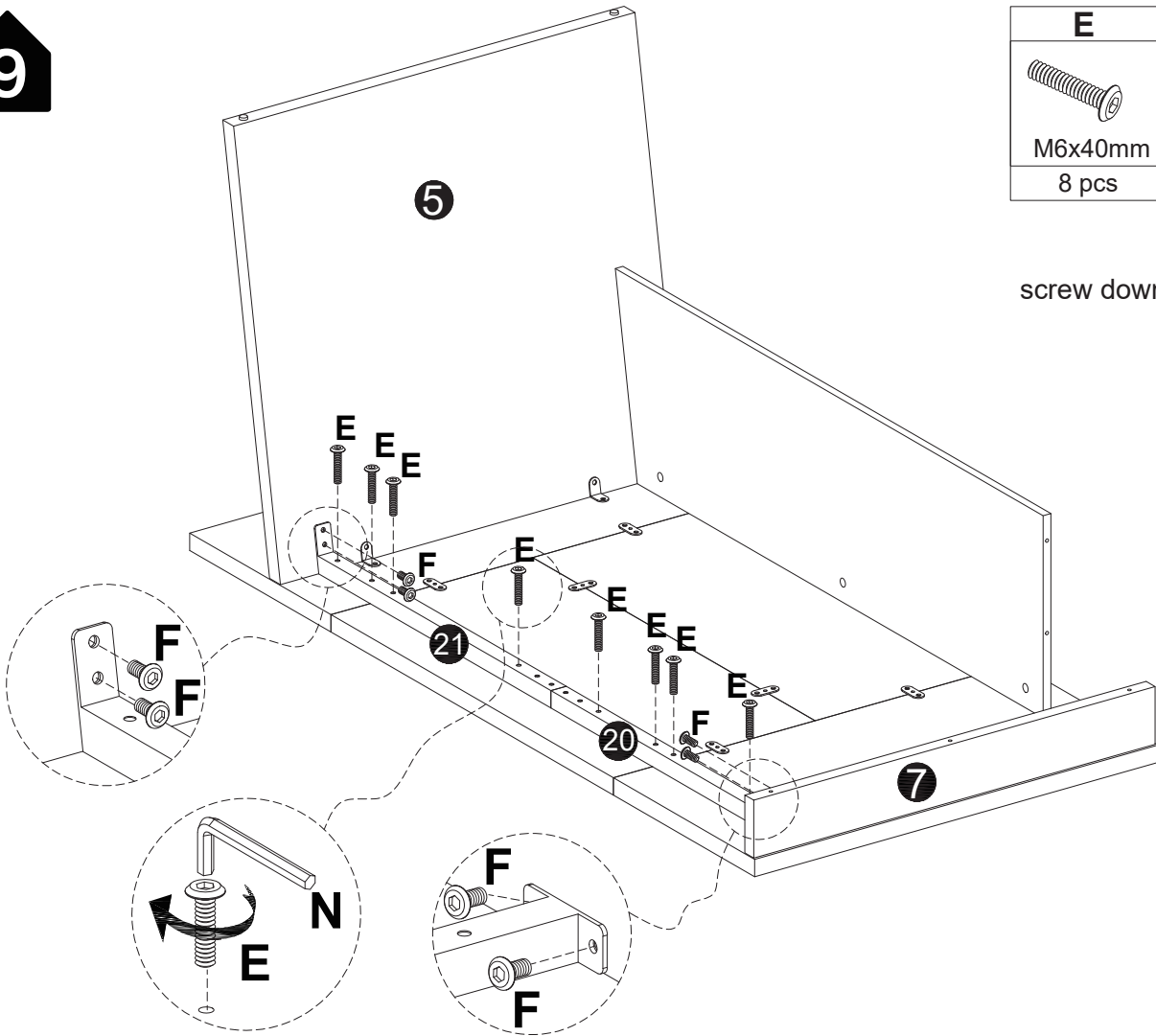

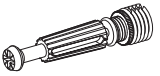

10

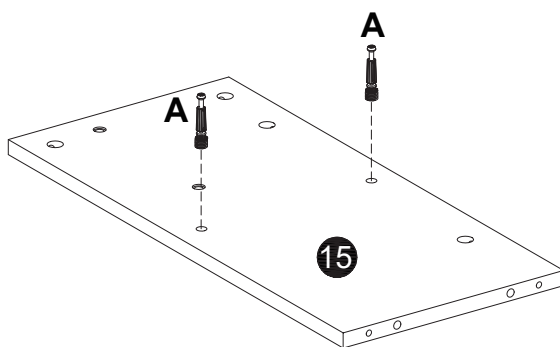
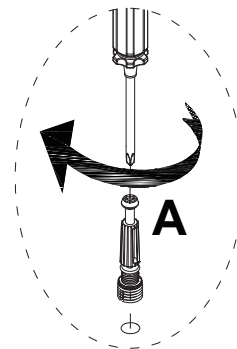
A

Ø6x40mm
2 pcs

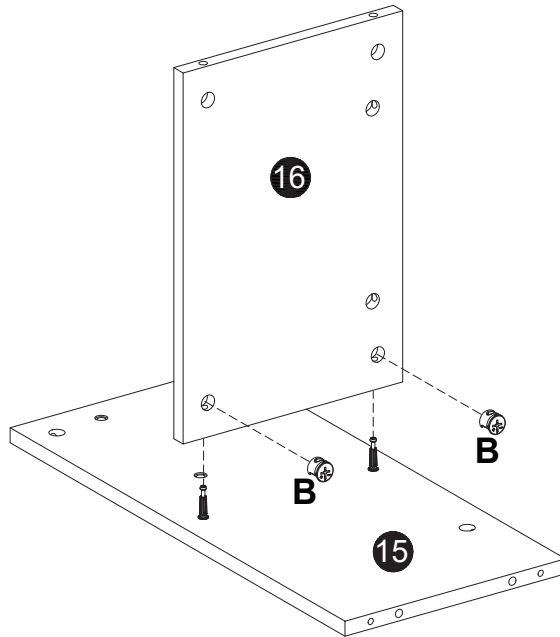

11



B

Ø15x12mm
2 pcs

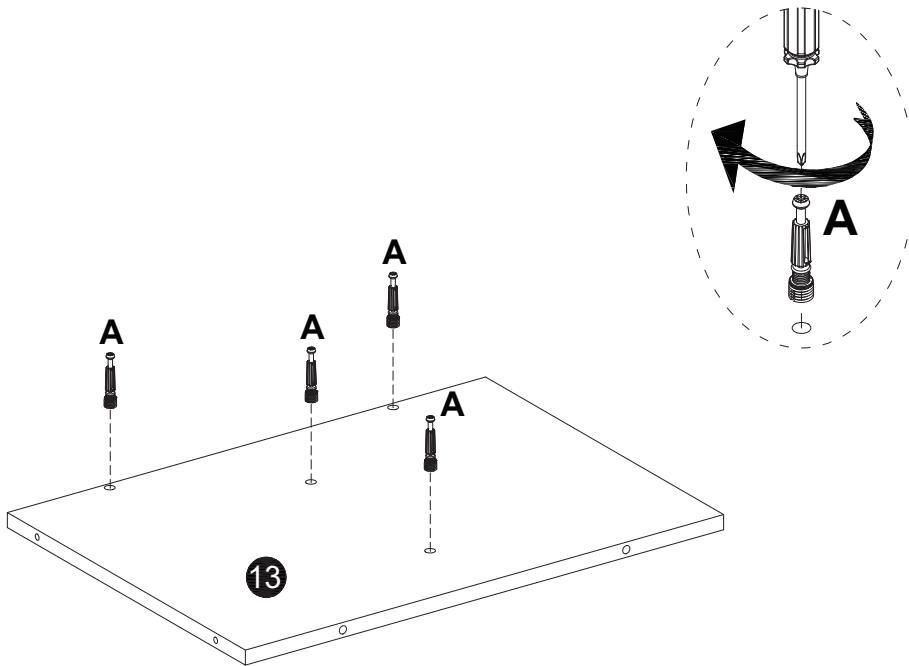
12

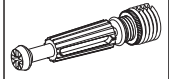

A

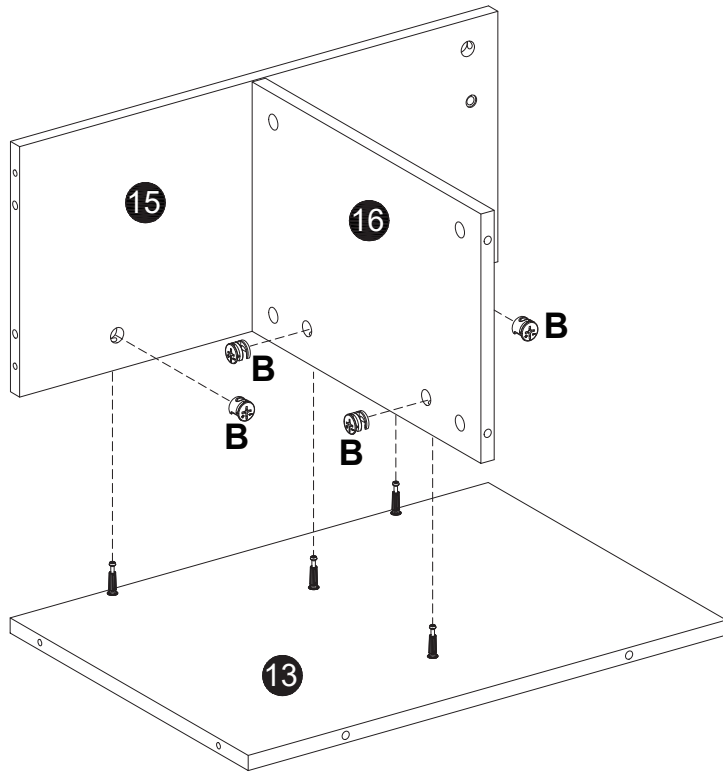
Ø6x40mm
4 pcs

13

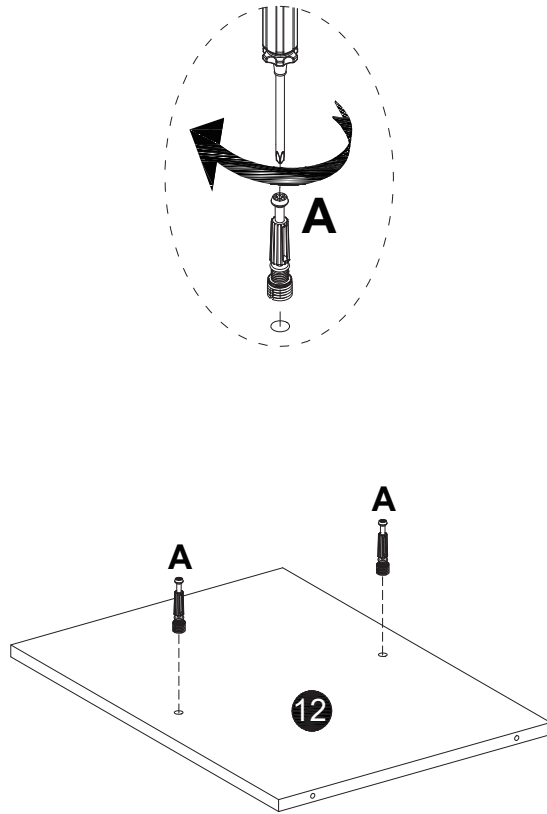
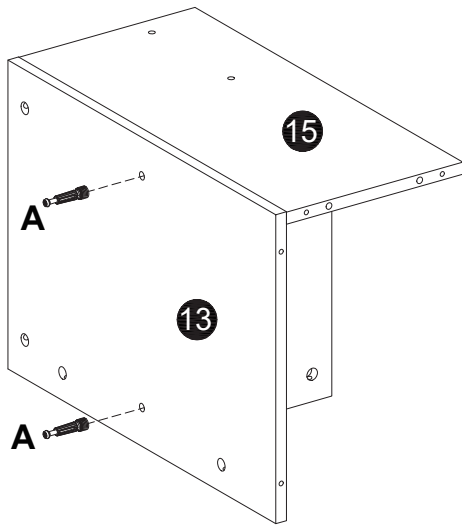

B

Ø15x12mm
4 pcs

14

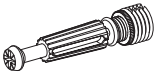

A

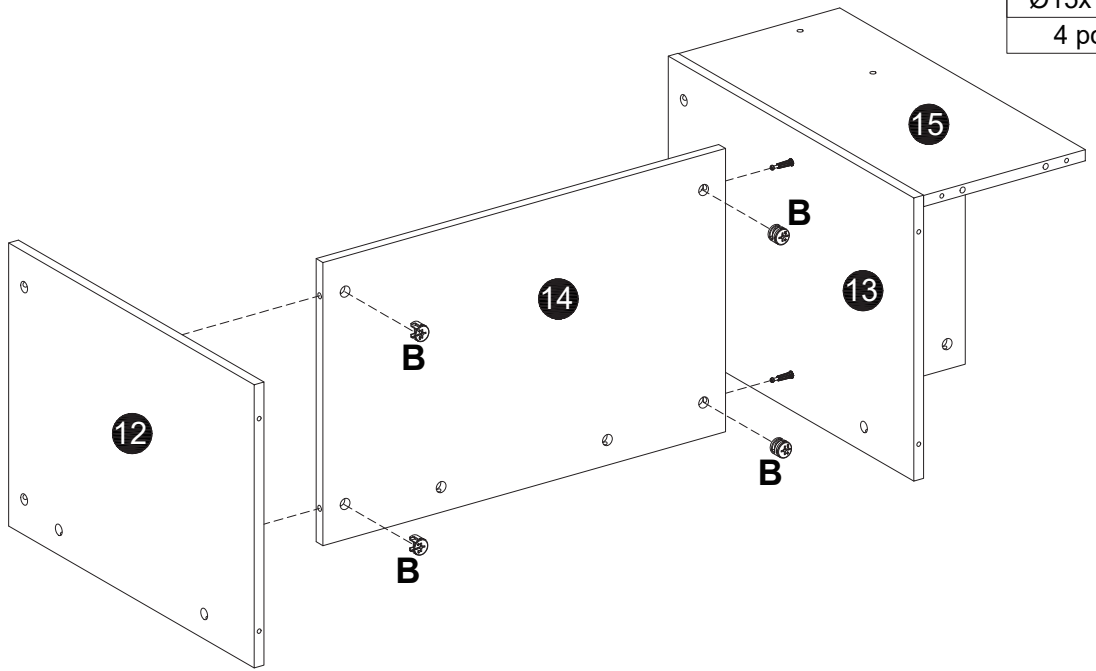
Ø6x40mm
4 pcs

15

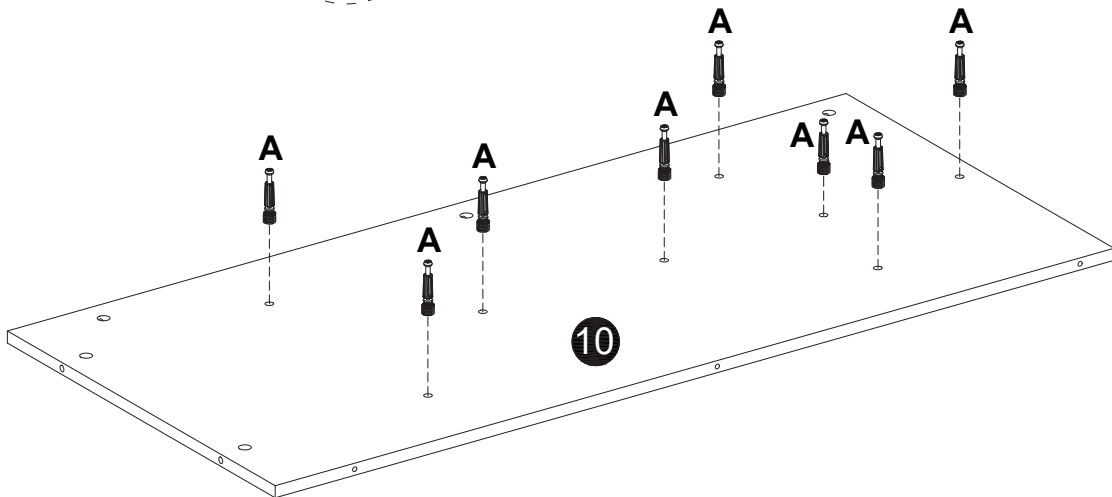
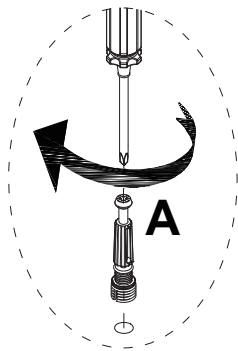

B

Ø15x12mm
4 pcs

16

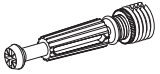

A

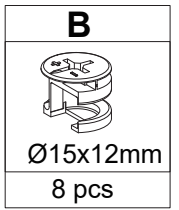
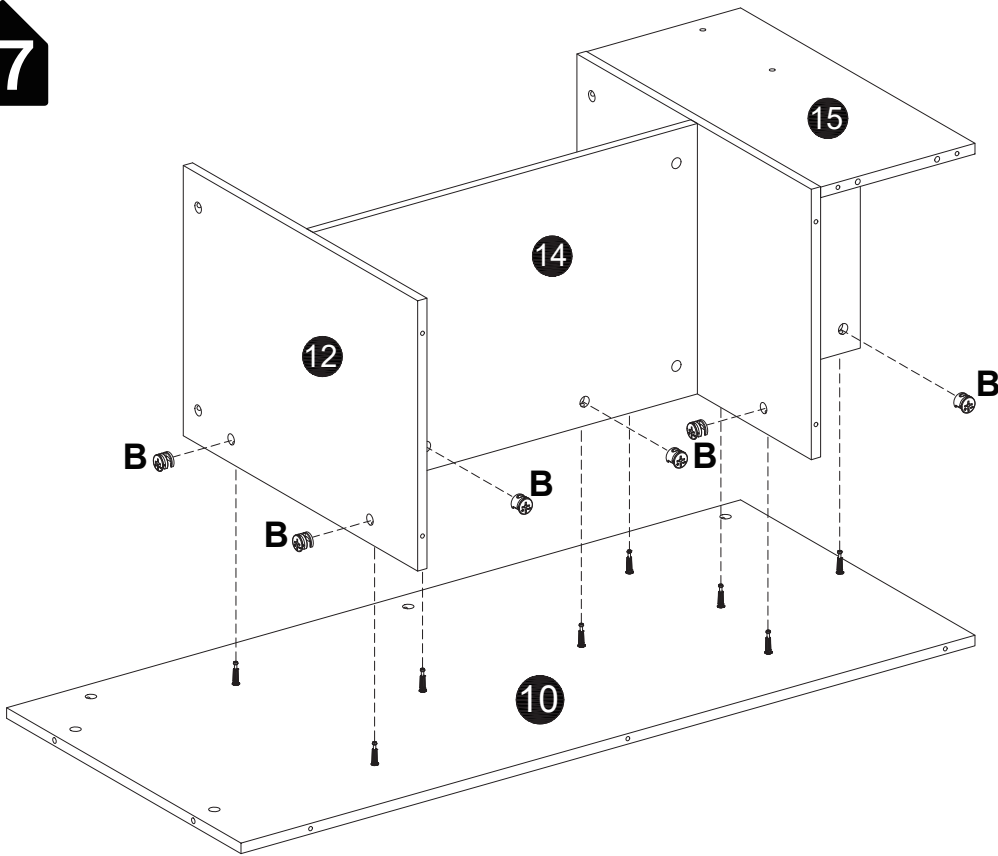
Ø6x40mm
8 pcs

17

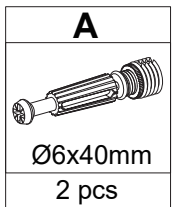
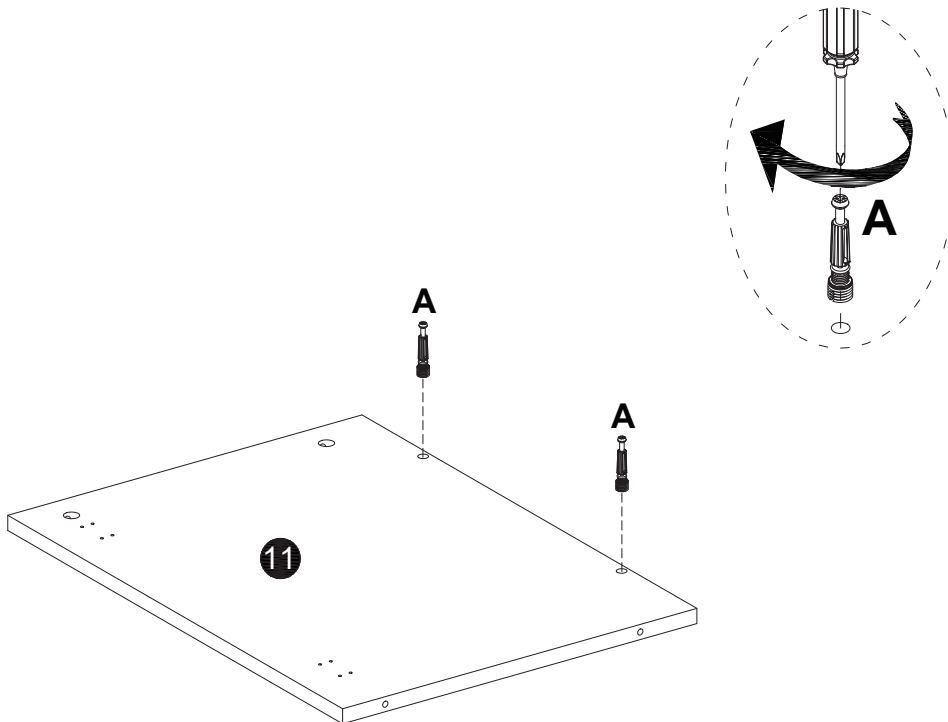

18



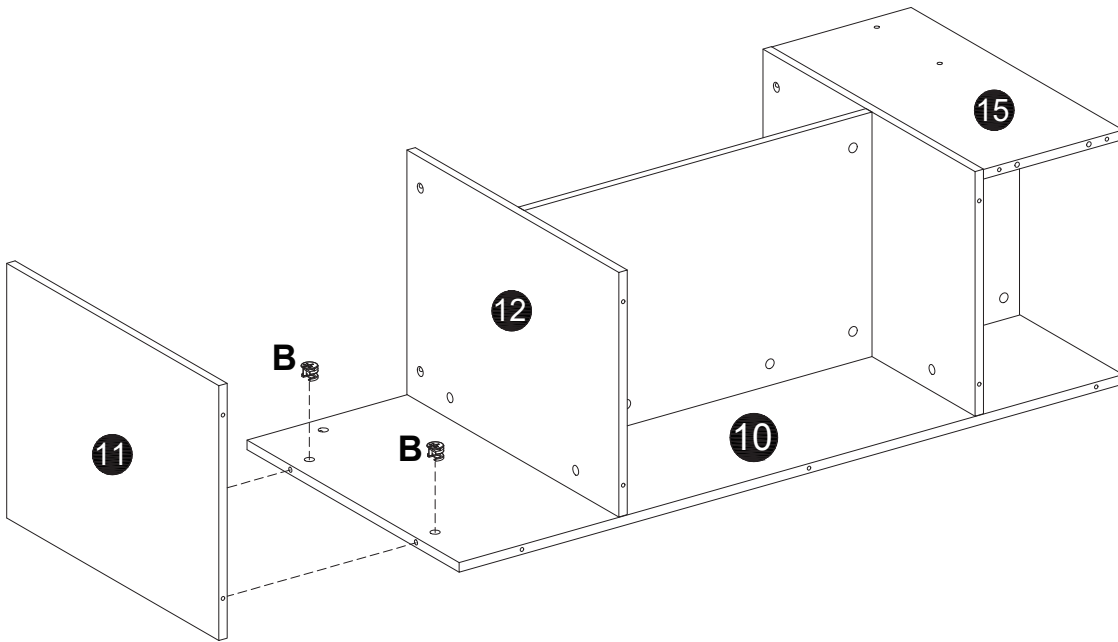

19

B

Ø15x12mm
2 pcs

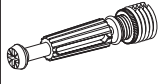

20

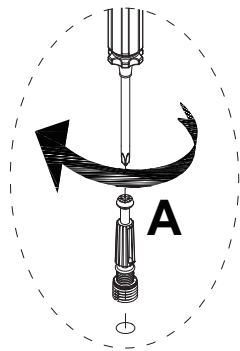
A	I
	
Ø6x40mm	Ø20x8mm
11 pcs	1 pc

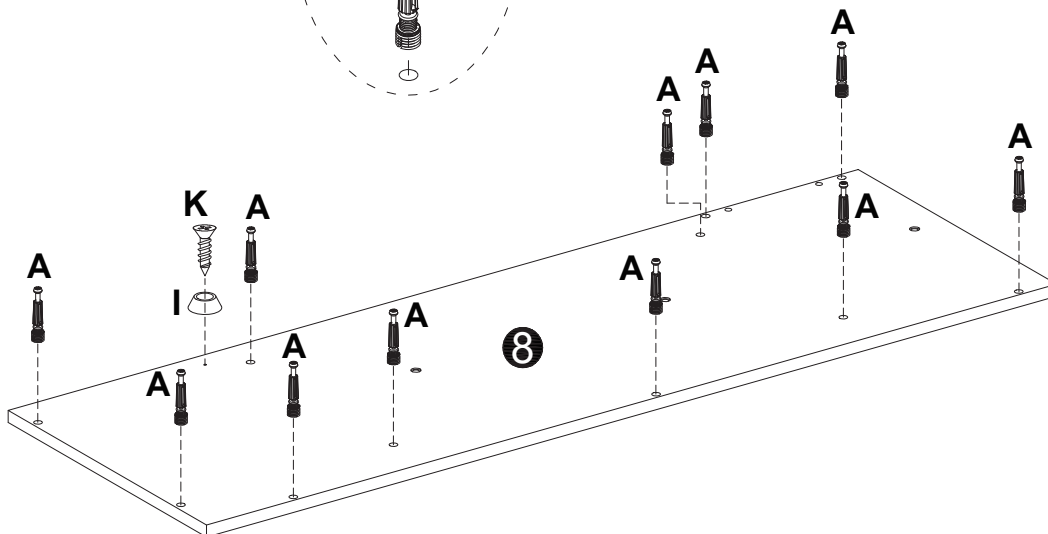

K

Ø3.5x14mm
1 pc

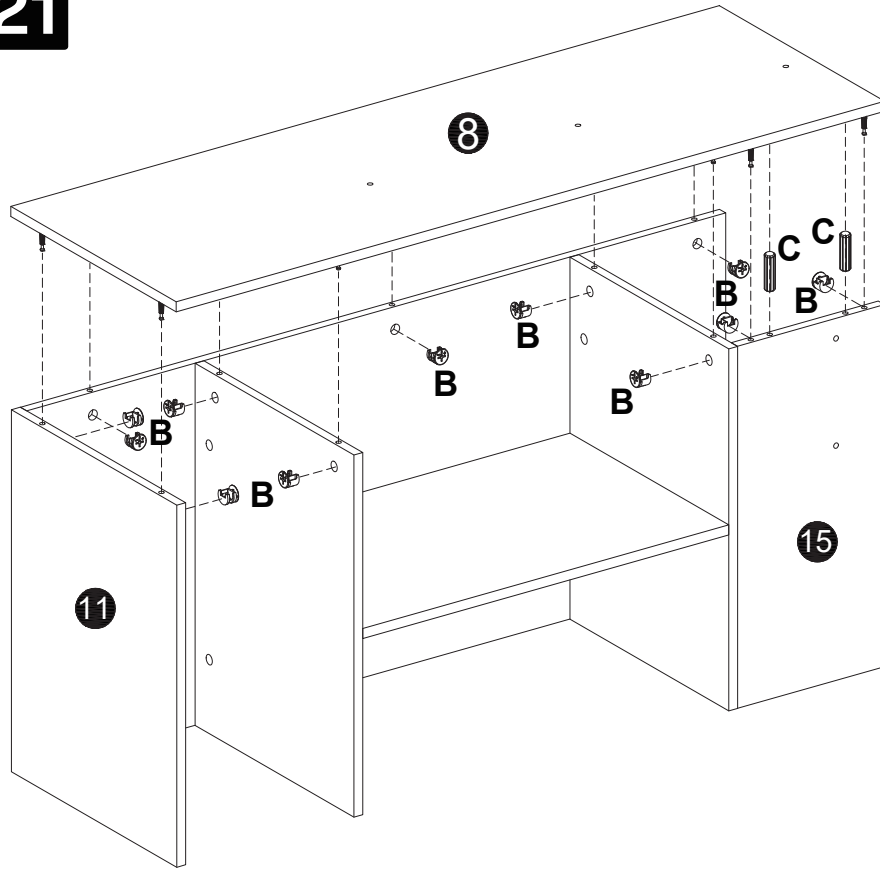

21

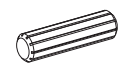

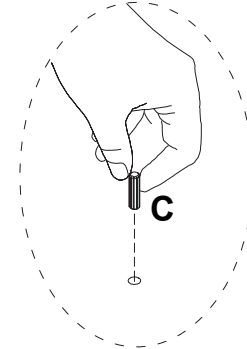
B	C
	
Ø15x12mm	Ø8x30mm
11 pcs	2 pcs



22

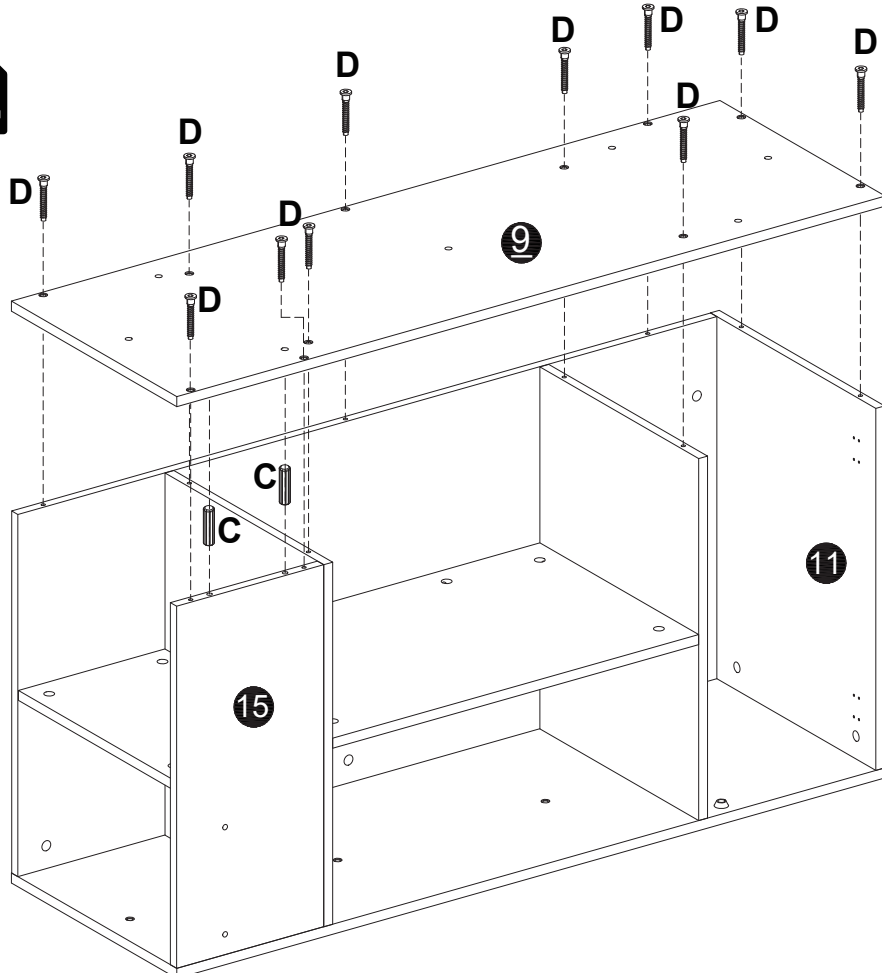

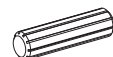
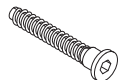
C	D
	
Ø8x30mm	Ø7x47mm
2 pcs	11 pcs

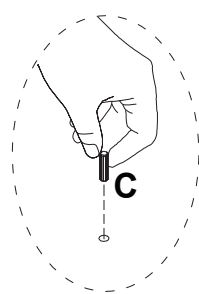
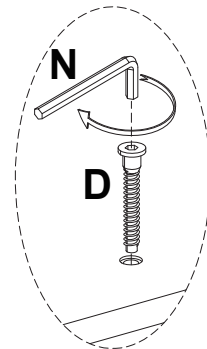

23

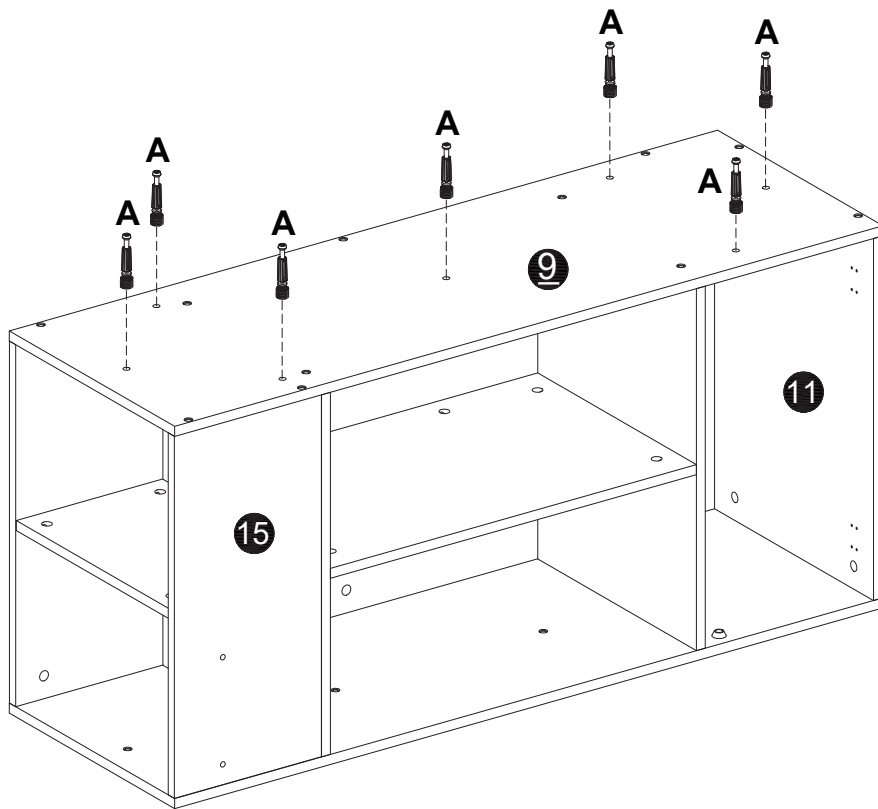

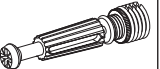
A

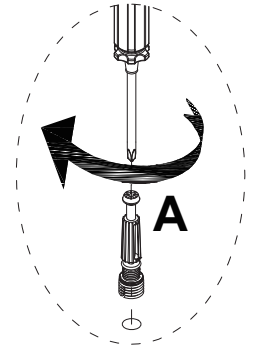
Ø6x40mm
7 pcs

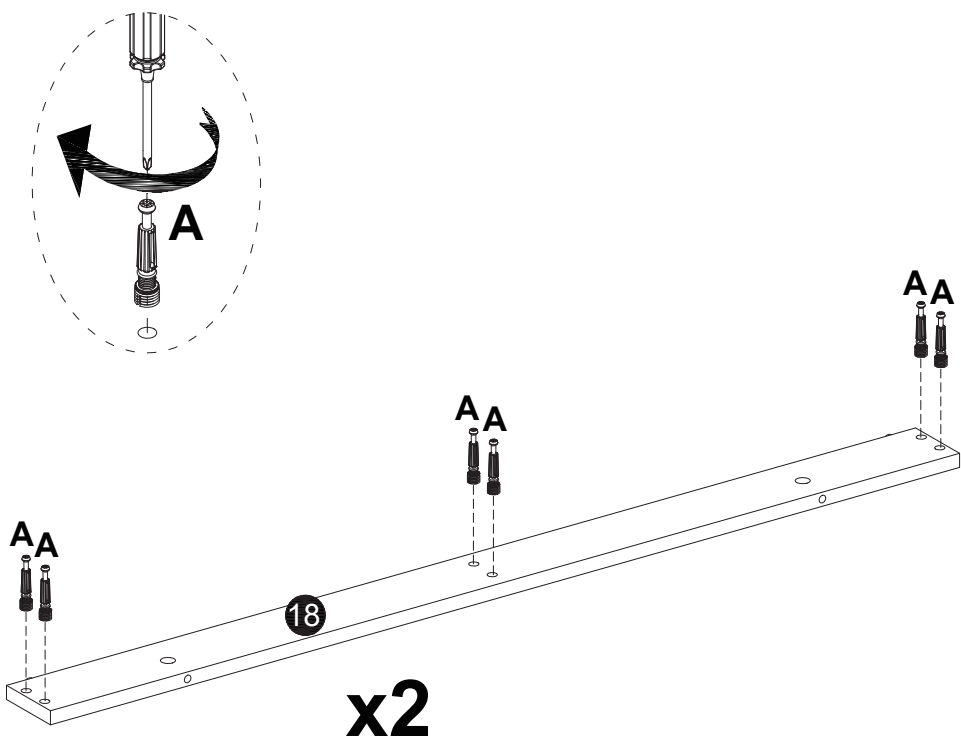

24

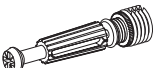

A

Ø6x40mm
12 pcs

25

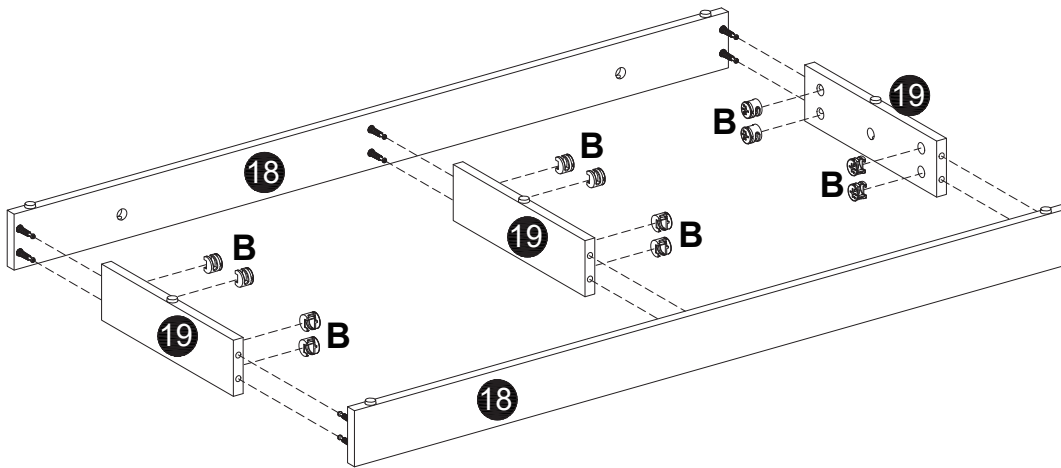
B

Ø15x12mm
12 pcs



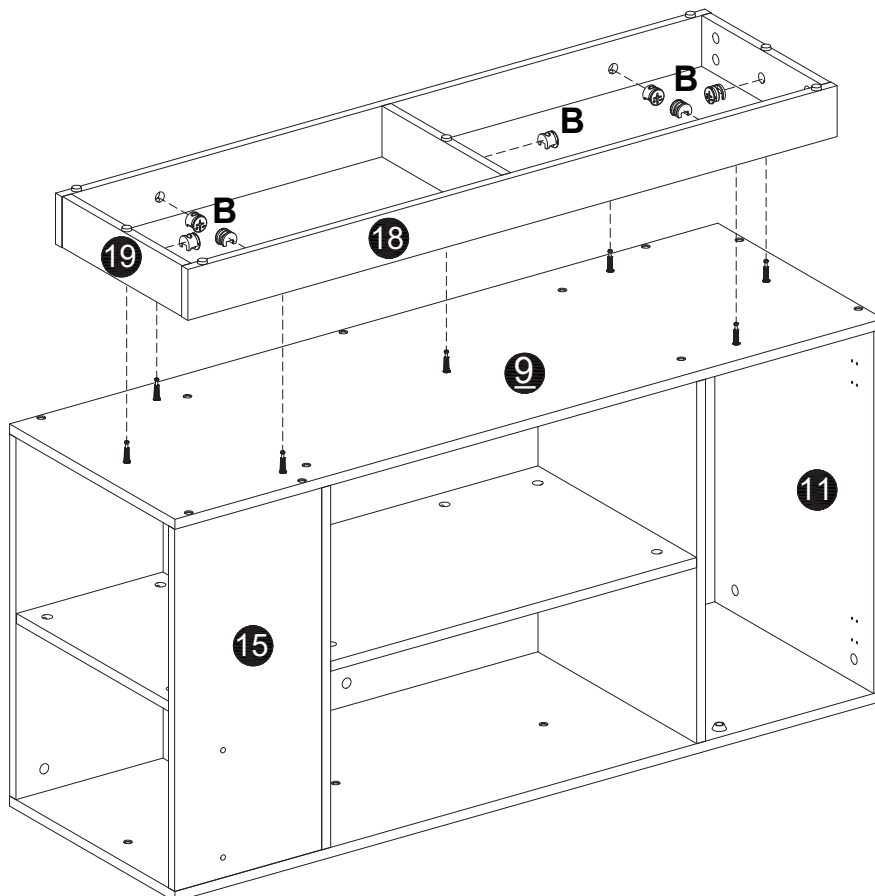

26

B

Ø15x12mm
7 pcs

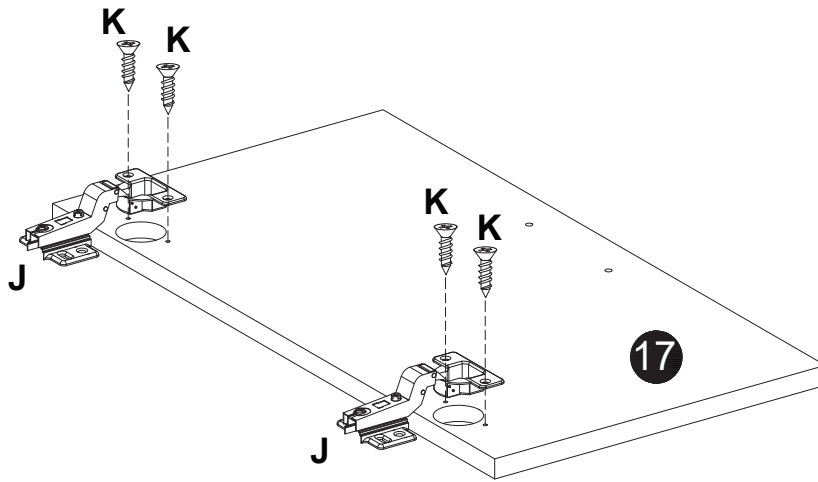

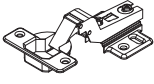

27

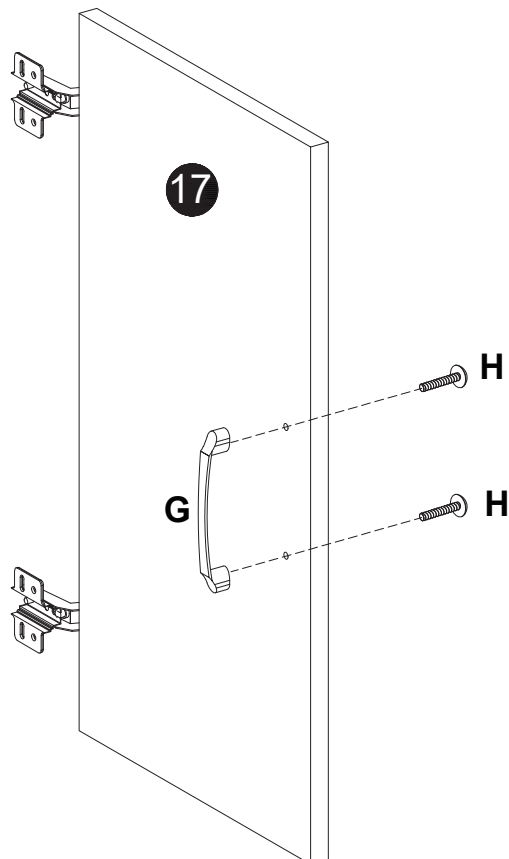

J	K
	
2 pcs	Ø3.5x14mm 4 pcs

28



G	H
	
125x12x20mm 1 pc	M4x18mm 2 pcs

K

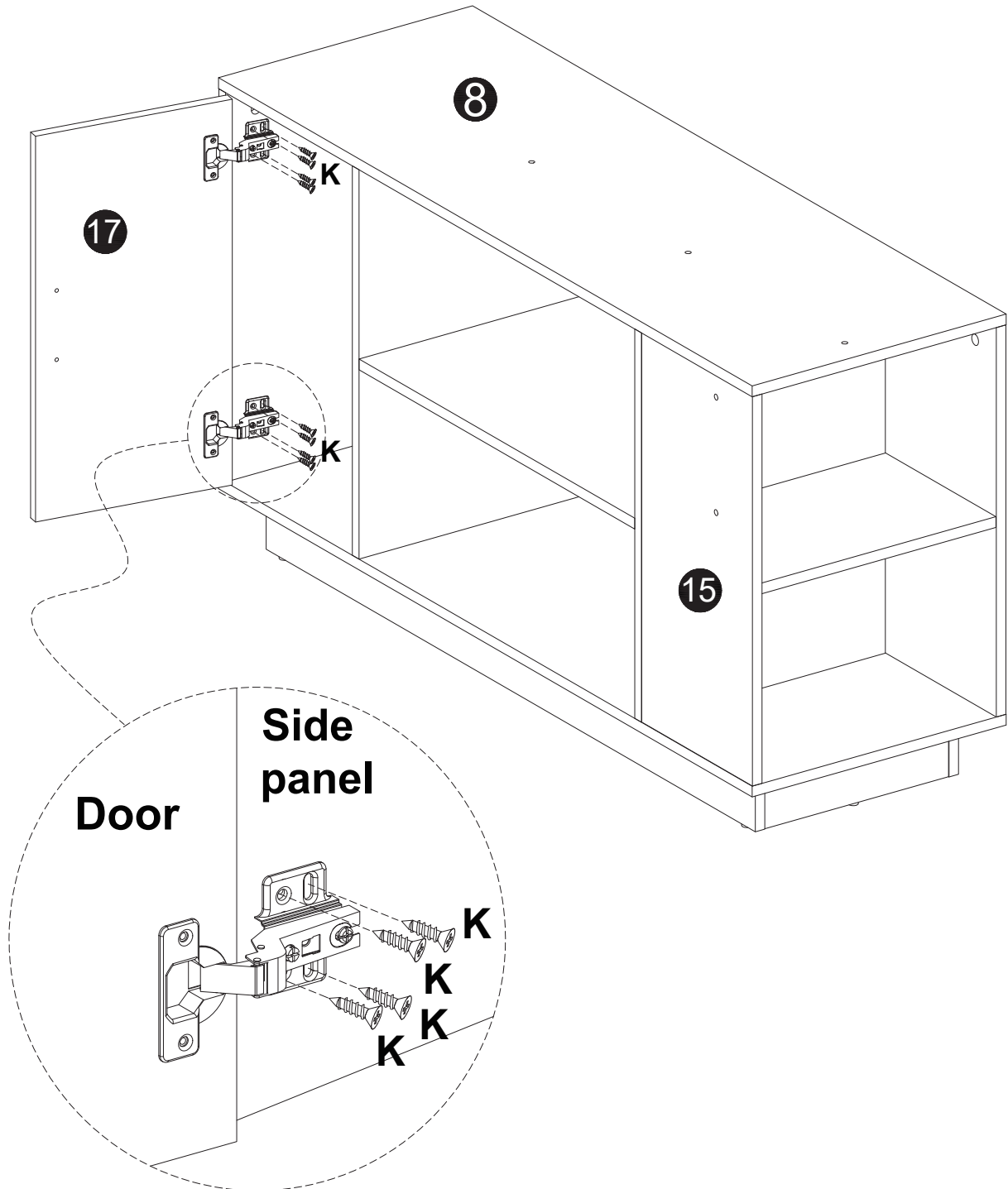
Ø3.5x14mm
8 pcs



To prevent the door hinge from falling off, please install 4 screws

Step 1

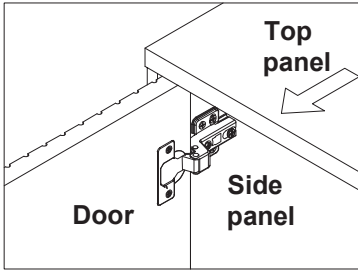
Open the door.



ADJUST YOUR DOORS TO MAKE THE GAPS MORE EVEN (OPTIONAL).

Step 2

Adjust the door panel to be flush with side panel and top panel edge.

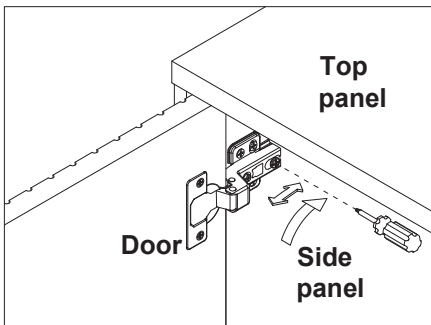

Loosen the screw indicated a little, adjust the hinge to the right position (see step 2a & 2b), then tighten the screw.

Step 2a MOVE DOOR OUT

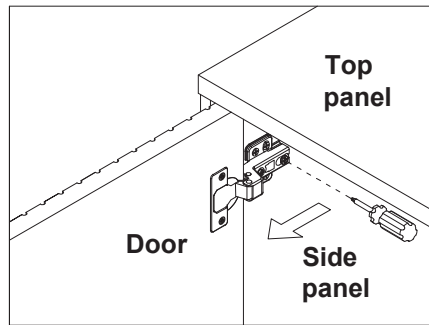
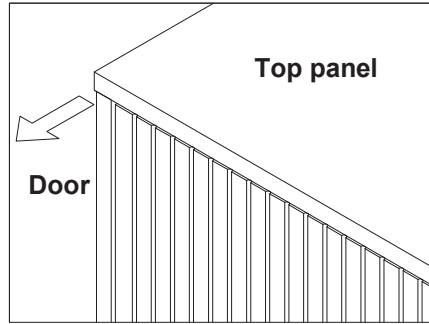

Pull the hinge forward a little.

Step 2b MOVE DOOR IN

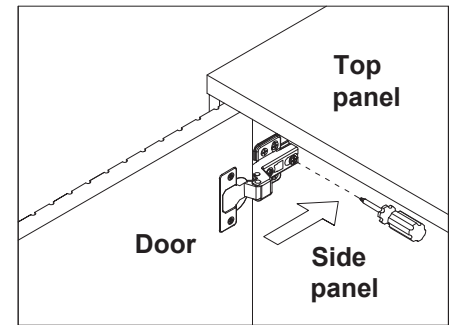
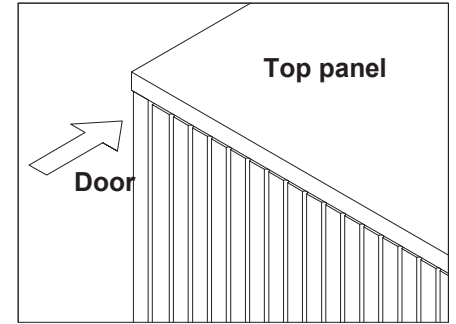

Push the hinge back a little.

Step 3

Adjust the gap between the door panel and the side panel.

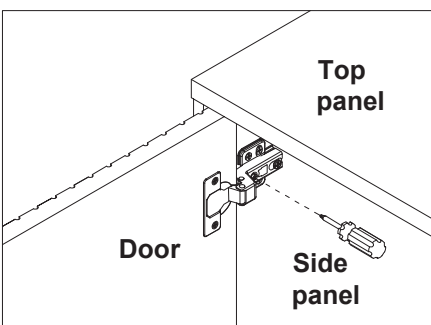

Loosen or tighten the screw indicated a little to adjust the gap between the door panels, adjust the hinge to the right position (see step 3a & 3b).

Step 3a MOVE DOOR LEFT

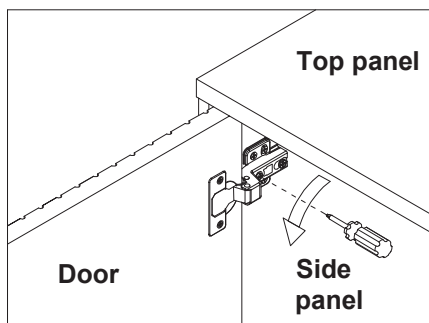
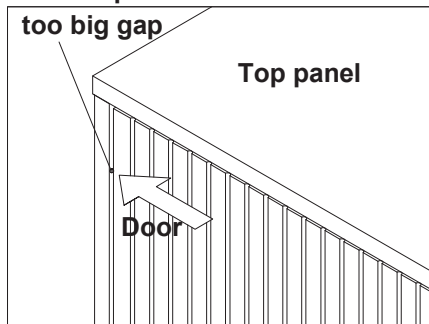

Turn the screw clockwise a little as shown to make the gap smaller

Step 3b MOVE DOOR RIGHT

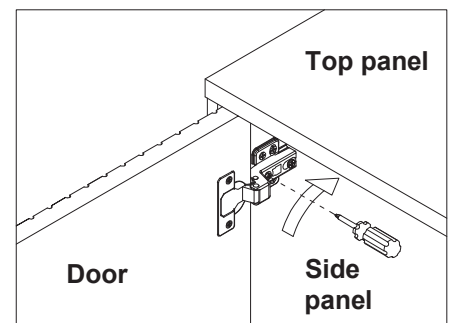
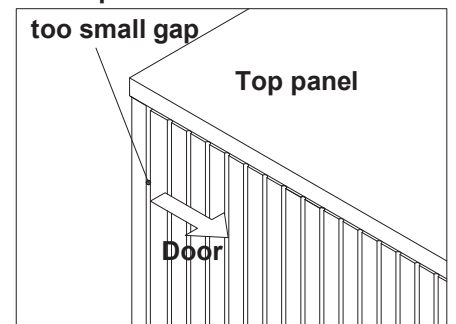

Turn the screw counterclockwise a little as shown to make the gap bigger

30

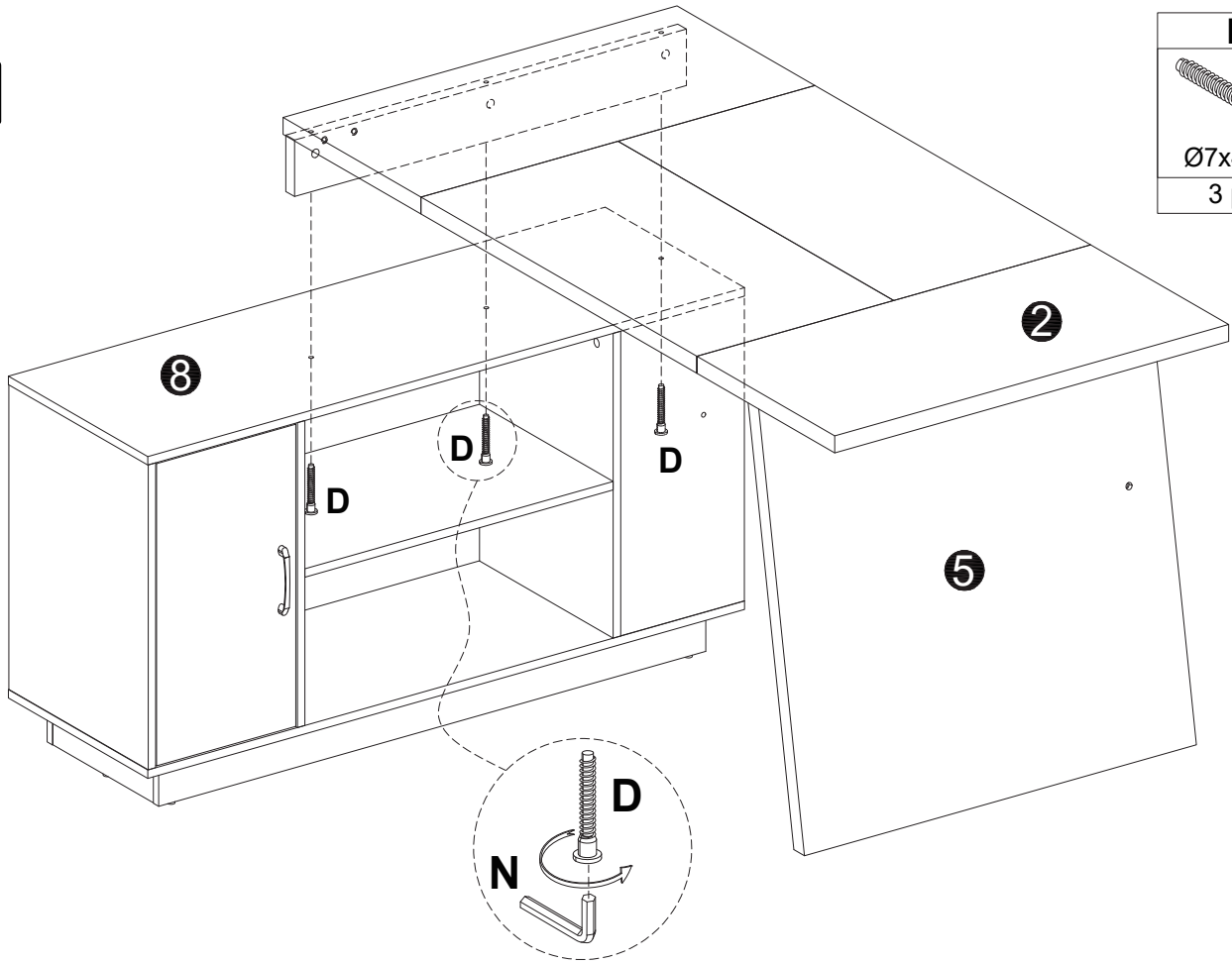

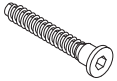

D

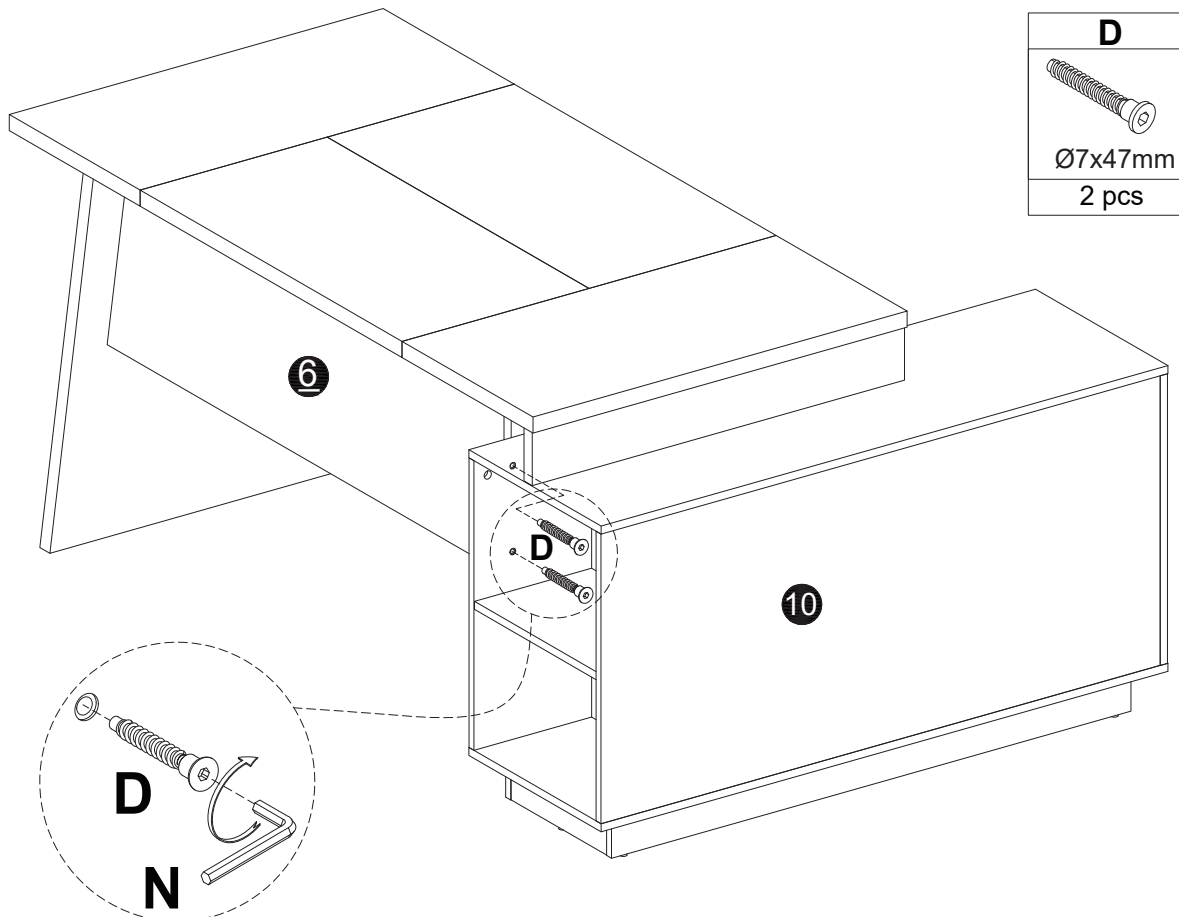
Ø7x47mm
3 pcs

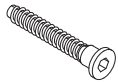
31



D

Ø7x47mm
2 pcs

32

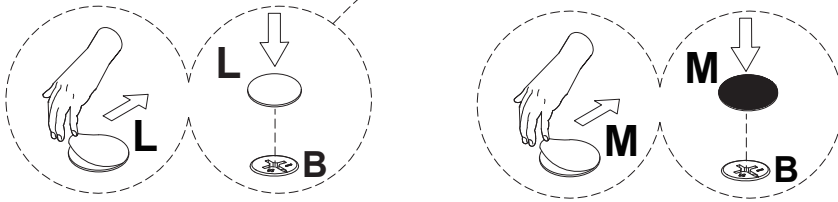
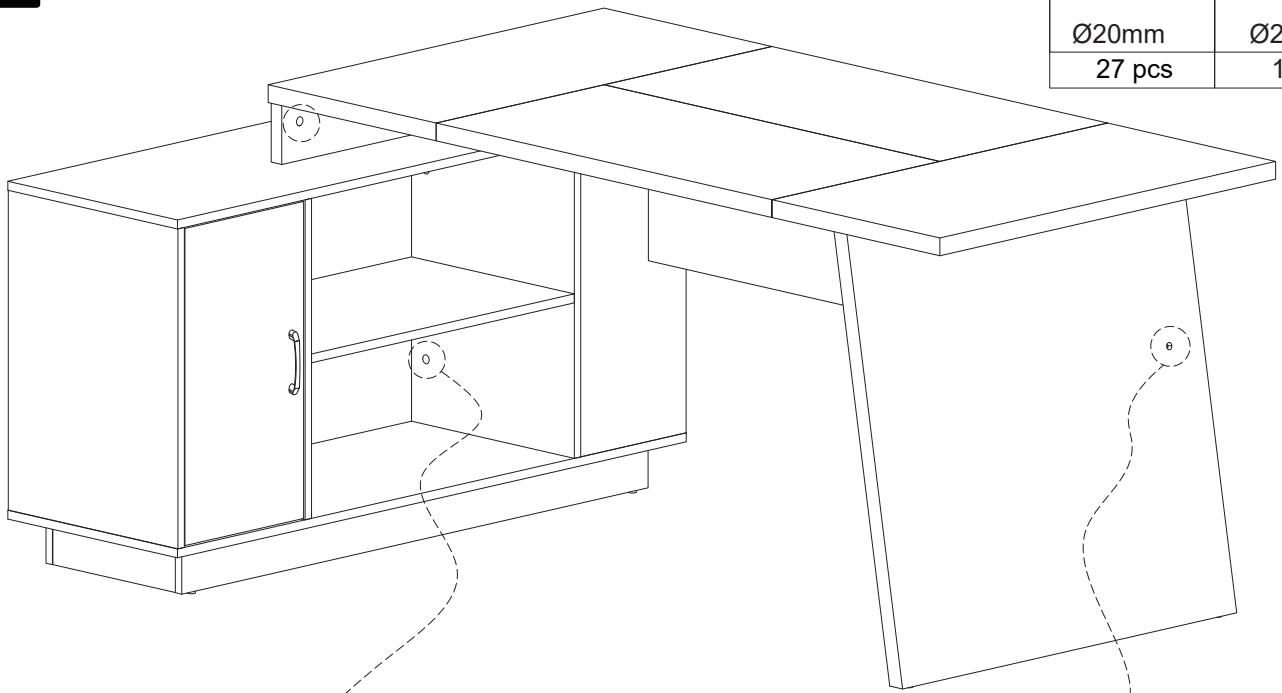
L	M
	
Ø20mm	Ø20mm
27 pcs	14 pcs

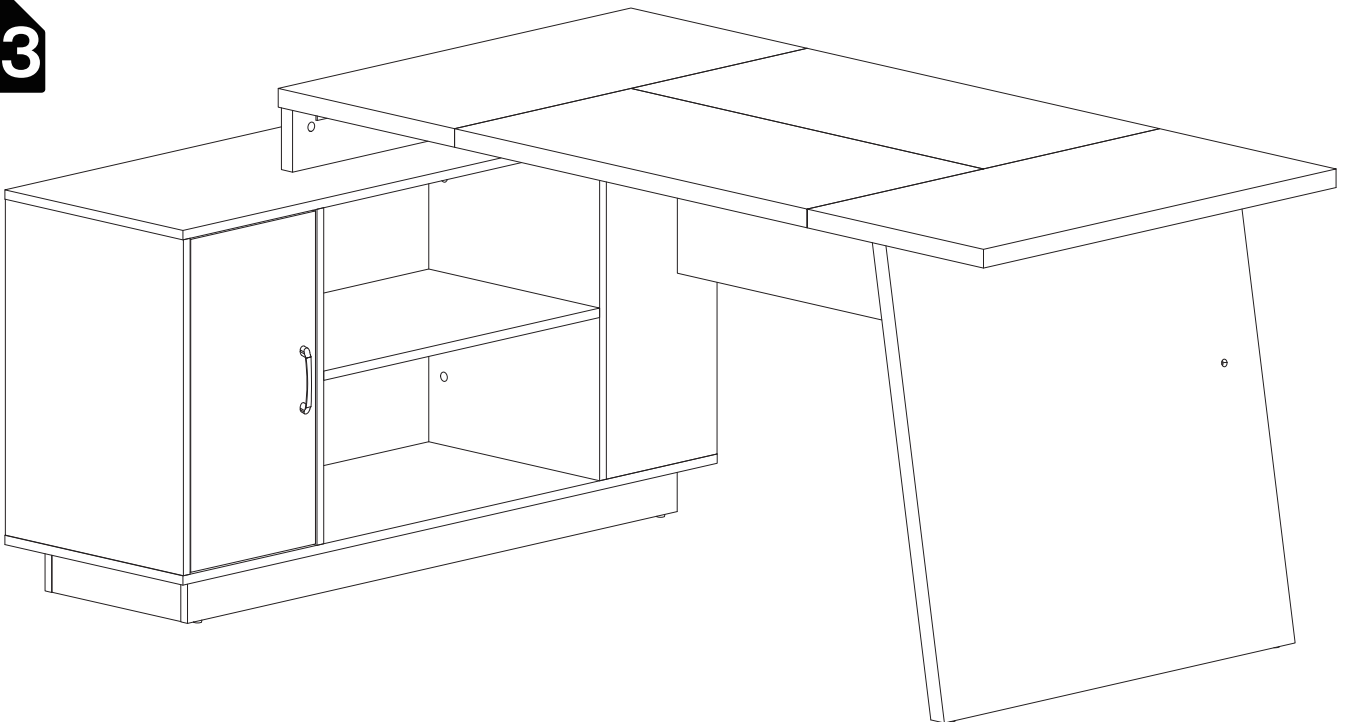

33



Thank you for your support!

