



**INSTRUCTIONS D'ASSEMBLAGE
ASSEMBLY INSTRUCTIONS**

**BUREAU -
48"L / BLANC / METAL ARGENT**



**COMPUTER DESK -
48"L / WHITE / SILVER METAL**



**POUR DE L'ASSISTANCE OU POUR COMMANDER
DES PIÈCES CONTACTEZ NOTRE DÉPARTEMENT
DE SERVICE À LA CLIENTÈLE.**

**FOR ASSISTANCE OR TO ORDER PARTS
CONTACT OUR CUSTOMER SERVICE DEPARTMENT**

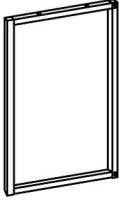

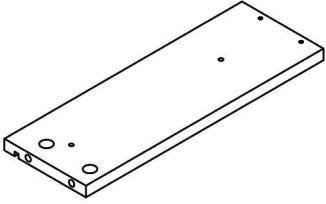
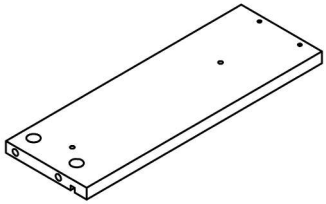
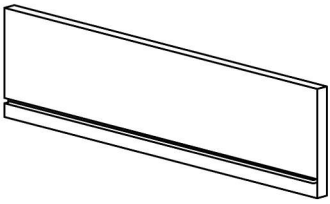
LISTE DES PIÈCES PARTS LIST

PIÈCE / PART #	IMAGE	DESCRIPTION	QTY / QTÉ
1		METAL LEG PATTE EN METAL	2
2		METAL LEG PATTE EN METAL	2
3		DRAWER SIDE PANEL PANNEAU DE CÔTÉ TIROIR	2
4		DRAWER SIDE PANEL PANNEAU DE CÔTÉ TIROIR	2
5		DRAWER BACK PANEL PANNEAU ARRIÈRE TIROIR	2

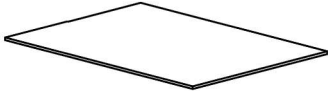
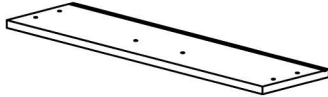
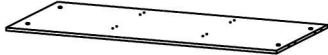
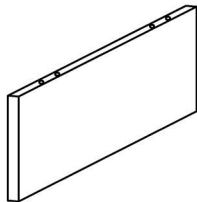
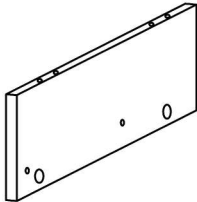
LISTE DES PIÈCES PARTS LIST

PIÈCE / PART #	IMAGE	DESCRIPTION	QTY / QTÉ
6		DRAWER BOTTOM PANEL PANNEAU DU BAS TIROIR	2
7		DRAWER FRONT PANEL PANNEAU AVANT TIROIR	2
8		DESK TOP SURFACE DU BUREAU	1
9		DIVIDER PANEL PANNEAU DE DIVISION	1
10		DIVIDER PANEL PANNEAU DE DIVISION	1

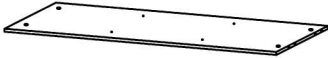
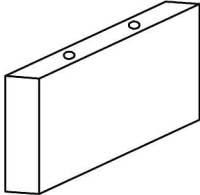
LISTE DES PIÈCES PARTS LIST

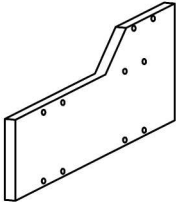
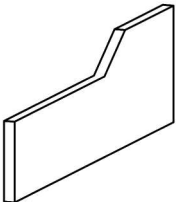
PIÈCE / PART #	IMAGE	DESCRIPTION	QTY / QTÉ
11		BOTTOM PANEL PANNEAU DU BAS	1
12		DIVIDER PANEL PANNEAU DE DIVISION	2
13		TOP PANEL PANNEAU DE SURFACE	1
14		FRONT FACING LEFT SIDE PANEL PANNEAU DE CÔTÉ GAUCHE	1
15		FRONT FACING RIGHT SIDE PANEL PANNEAU DE CÔTÉ AVANT DROIT	1

LISTE DES PIÈCES
PARTS LIST

PIÈCE / PART #	IMAGE	DESCRIPTION	QTY / QTÉ
16		BACK PANEL PANNEAU ARRIÈRE	1

LISTE DES PIÈCES DE MONTAGE HARDWARE LIST

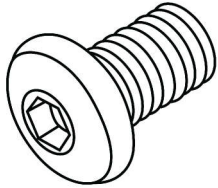
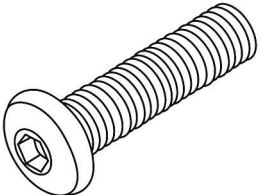
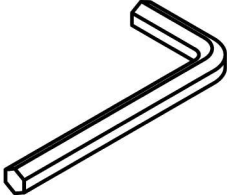
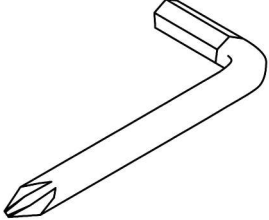
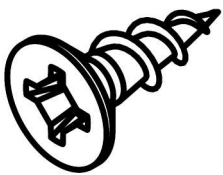
PIÈCE / PART #	IMAGE	DESCRIPTION	QTY / QTÉ
A		ASSEMBLING BOLT - Ø1/4" X 1 1/8" BOULON D'ASSEMBLAGE - Ø1/4" X 1 1/8"	8
B		ASSEMBLING BOLT - Ø1/4" X 1 5/8" BOULON D'ASSEMBLAGE - Ø1/4" X 1 5/8"	4
C		HEX KEY CLÉ HEXAGONALE	1
D		HEX KEY CLÉ HEXAGONALE	1
E		ASSEMBLING SCREW - Ø1/8" X 1/2" VIS D'ASSEMBLAGE - Ø1/8" X 1/2"	16

LISTE DES PIÈCES DE MONTAGE HARDWARE LIST

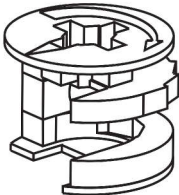
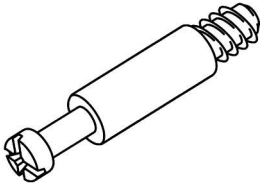
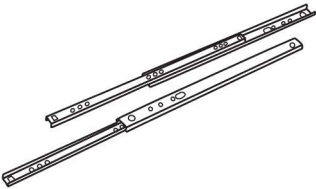
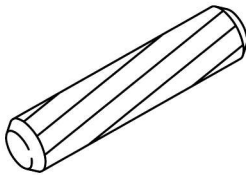
PIÈCE / PART #	IMAGE	DESCRIPTION	QTY / QTÉ
F		ASSEMBLING SCREW - Ø1/8" X 1 3/8" VIS D'ASSEMBLAGE - Ø1/8" X 1 3/8"	8
G		CAM LOCK CONNECTOR - Ø5/8" X 1/2" ÉCROU CAM LOCK - Ø5/8" X 1/2"	20
H		CAM LOCK SCREW - Ø1/4" X 1 3/8" VIS CAM LOCK - Ø1/4" X 1 3/8"	20
I		METAL DRAWER SLIDE COULISSE DE MÉTAL	4
J		WOOD DOWEL - Ø3/8" X 1 1/8" GOUJON DE BOIS - Ø3/8" X 1 1/8"	28

LISTE DES PIÈCES DE MONTAGE
HARDWARE LIST

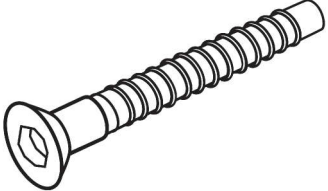
PIÈCE / PART #	IMAGE	DESCRIPTION	QTY / QTÉ
K		ASSEMBLING SCREW - Ø1/4" X 1 5/8" VIS D'ASSEMBLAGE - Ø1/4" X 1 5/8"	13

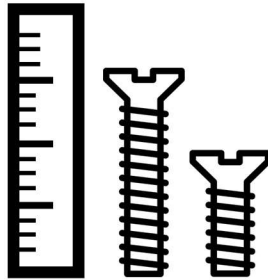

OUTIL DE VÉRIFICATION DE DIMENSIONS DES PIÈCES
HARDWARE DIMENSIONS VERIFICATION TOOL

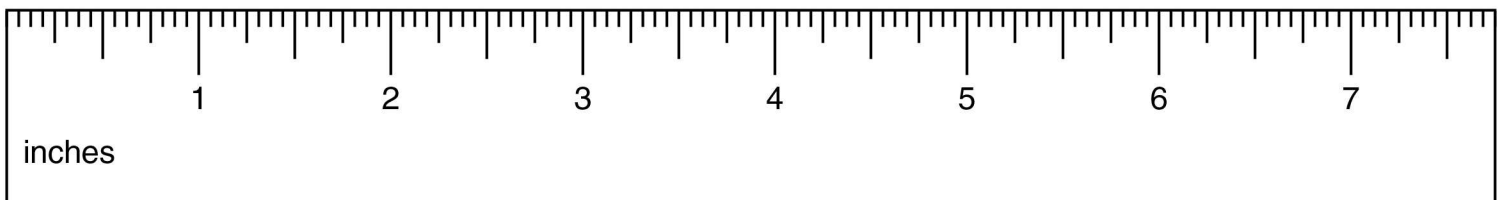

ÉTAPE / STEP 1

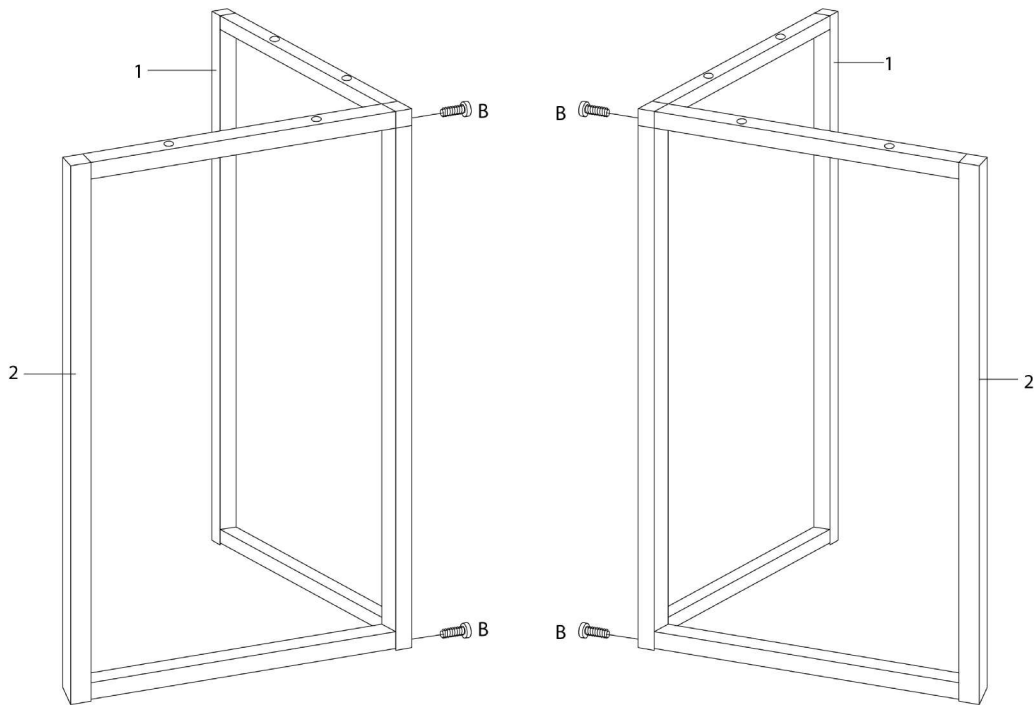

ÉTAPE / STEP 2

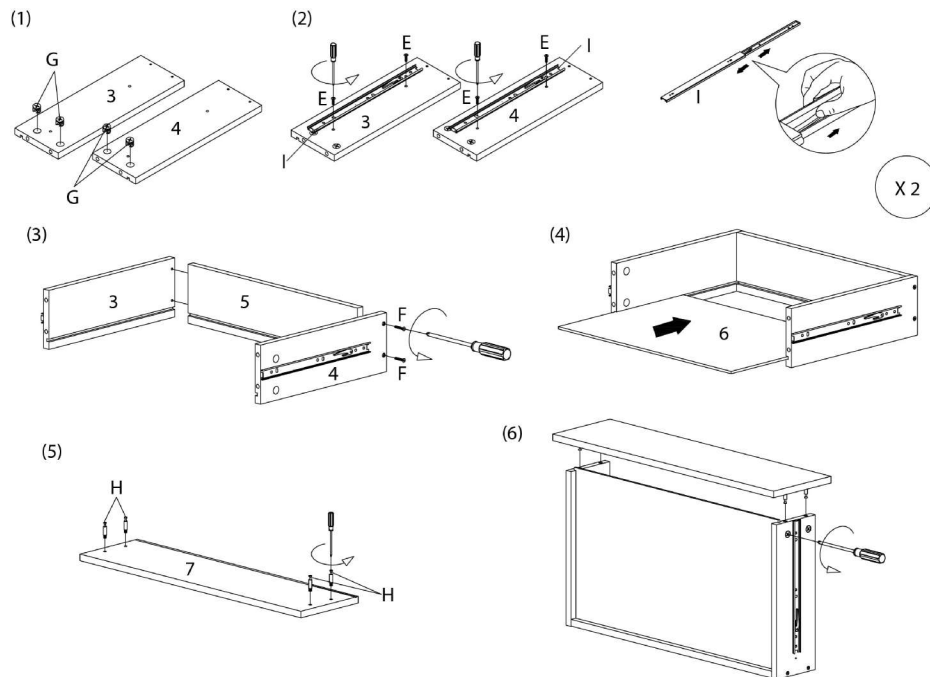

ÉTAPE / STEP 3

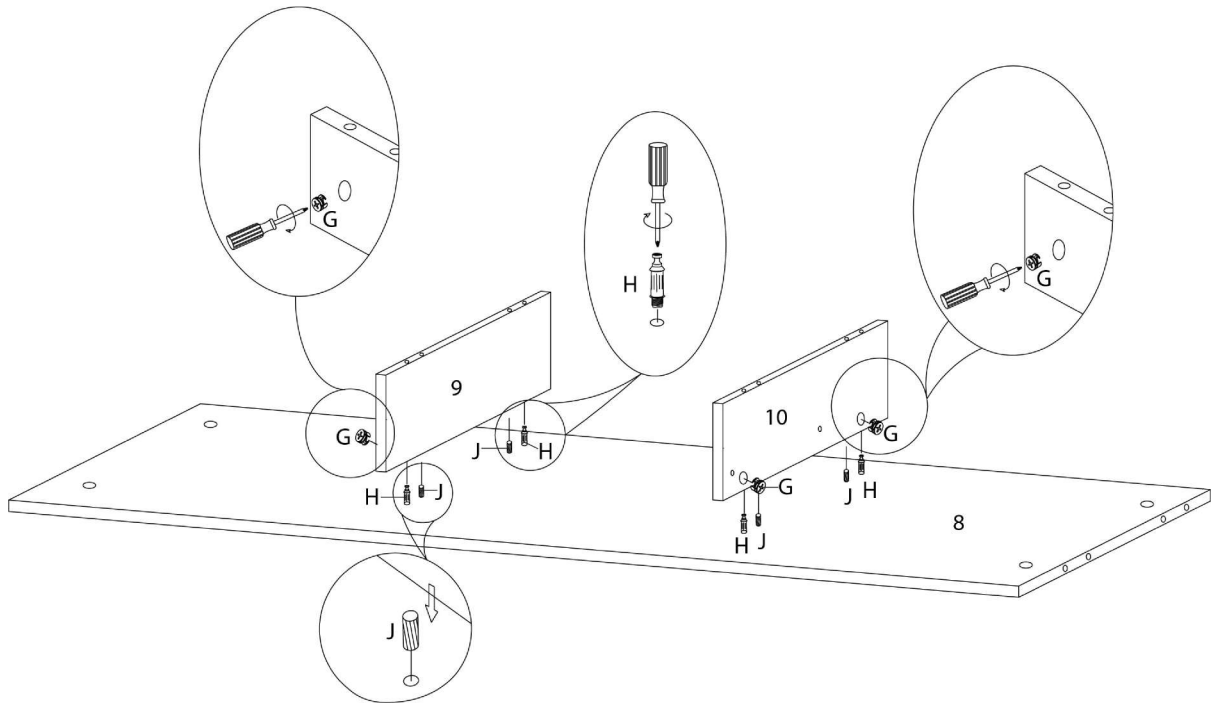

ÉTAPE / STEP 4

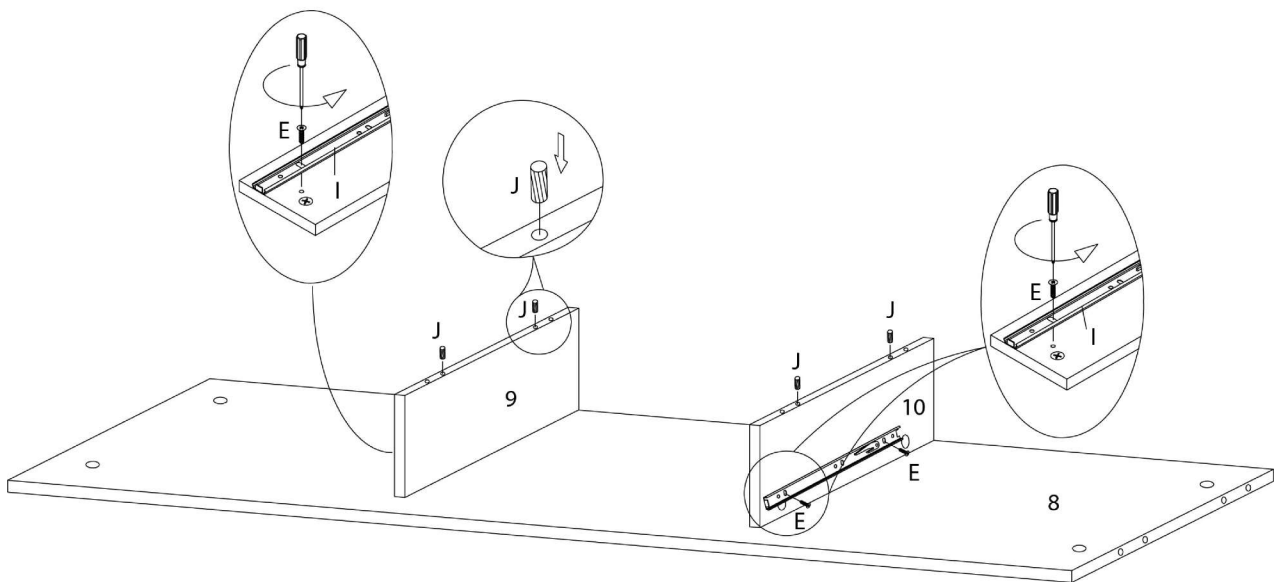

ÉTAPE / STEP 5

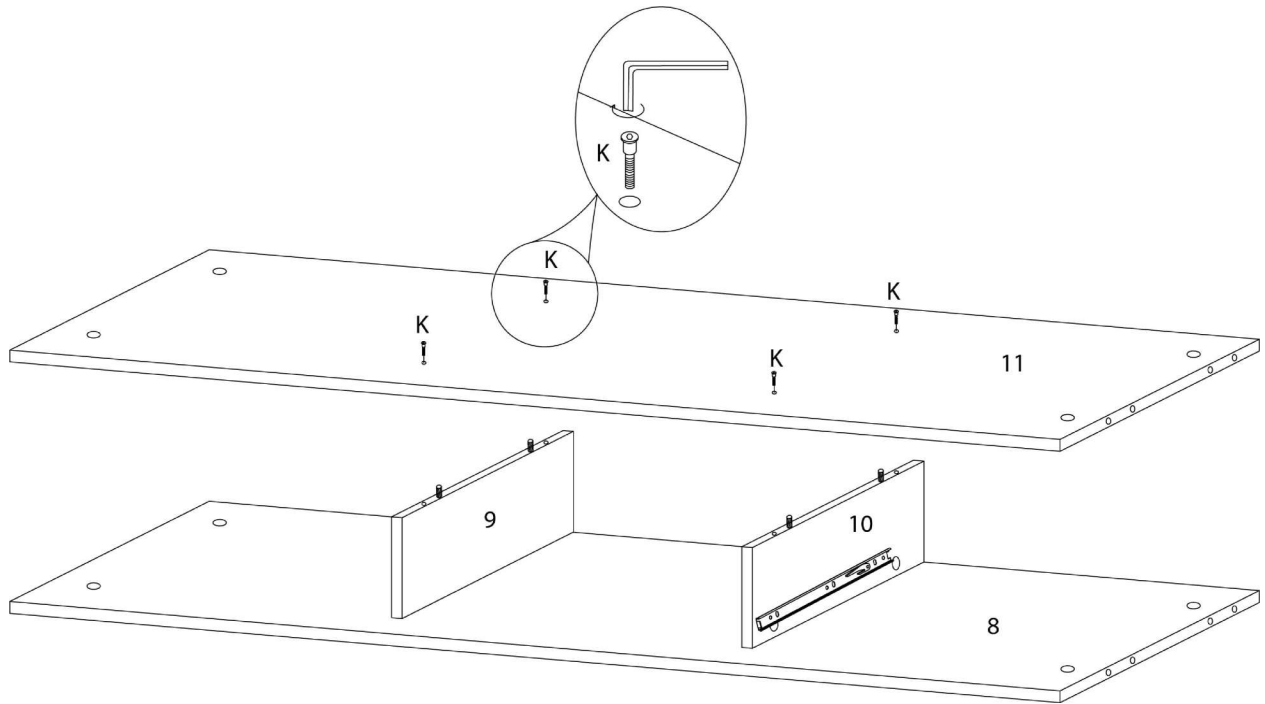

ÉTAPE / STEP 6

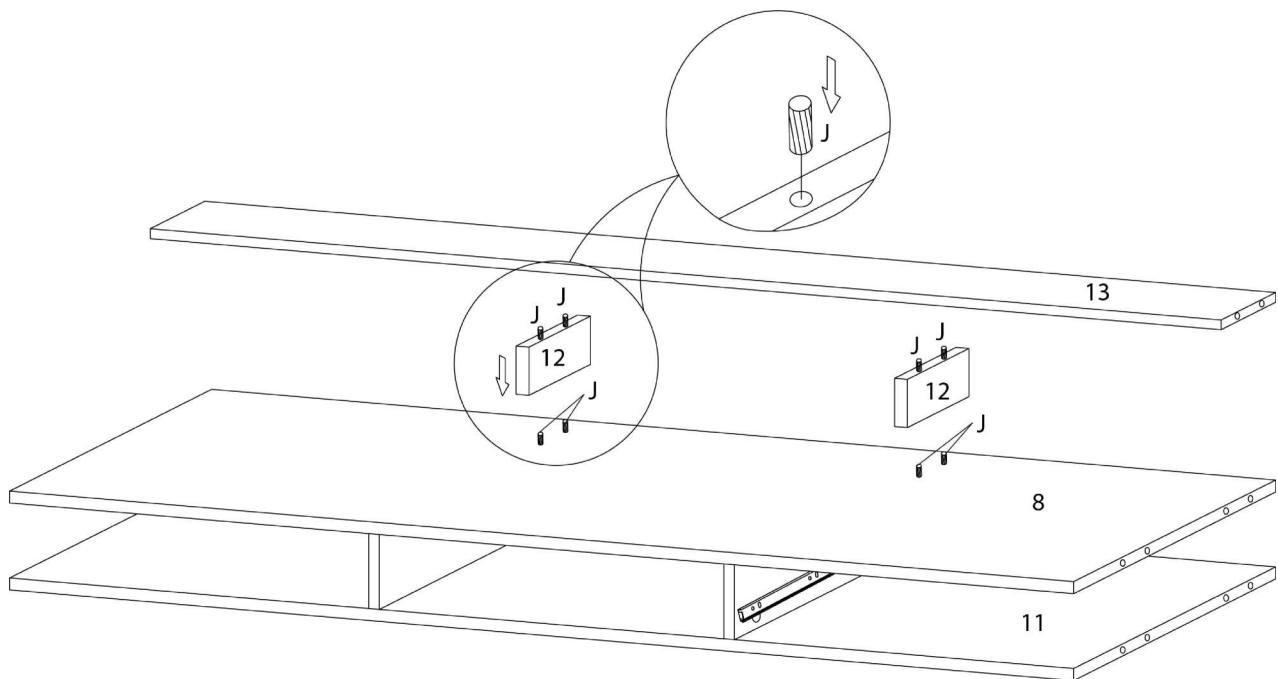

ÉTAPE / STEP 7

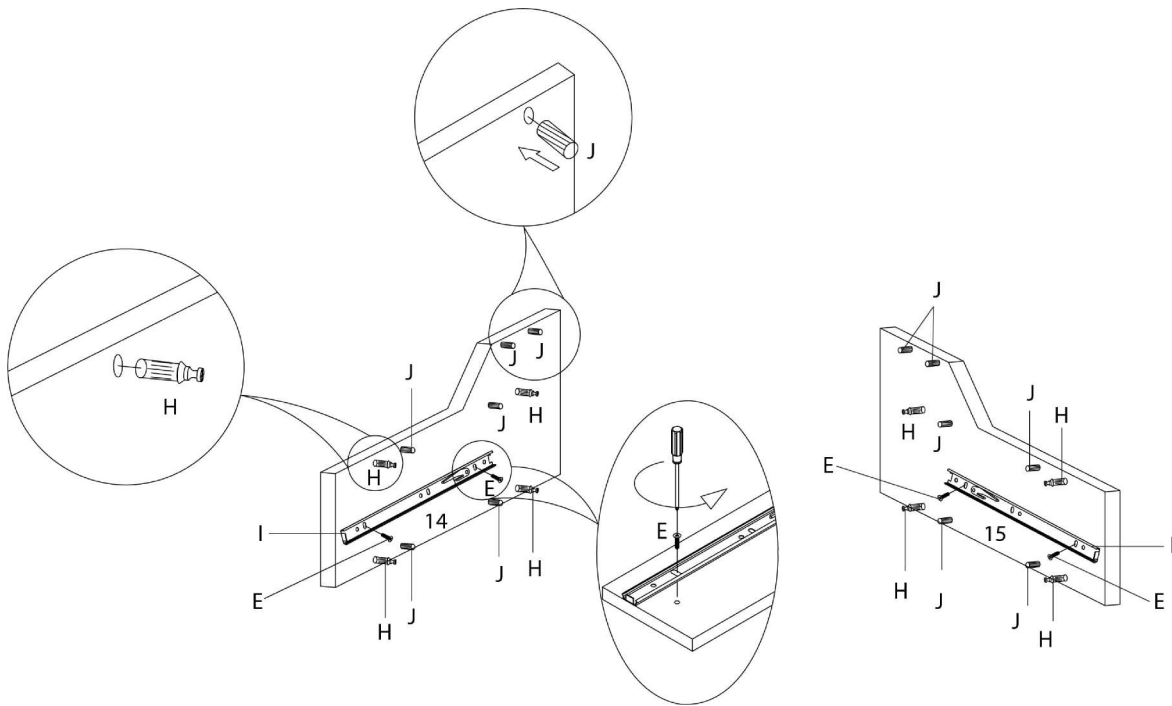

ÉTAPE / STEP 8

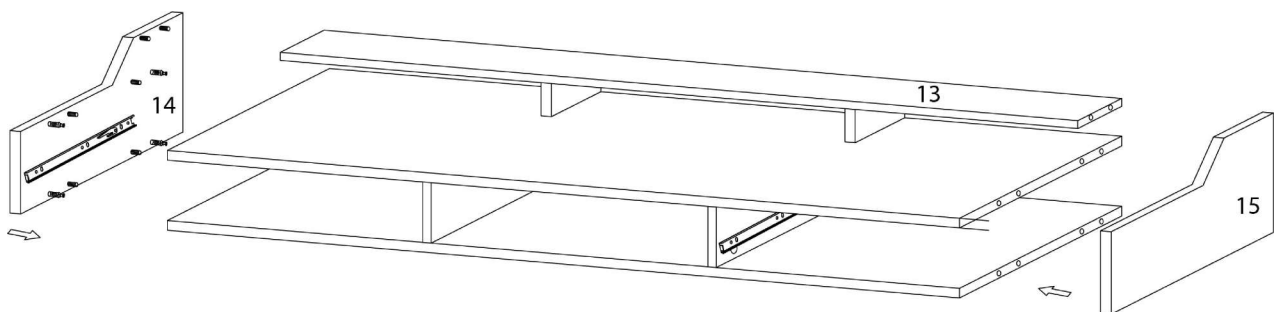

ÉTAPE / STEP 9

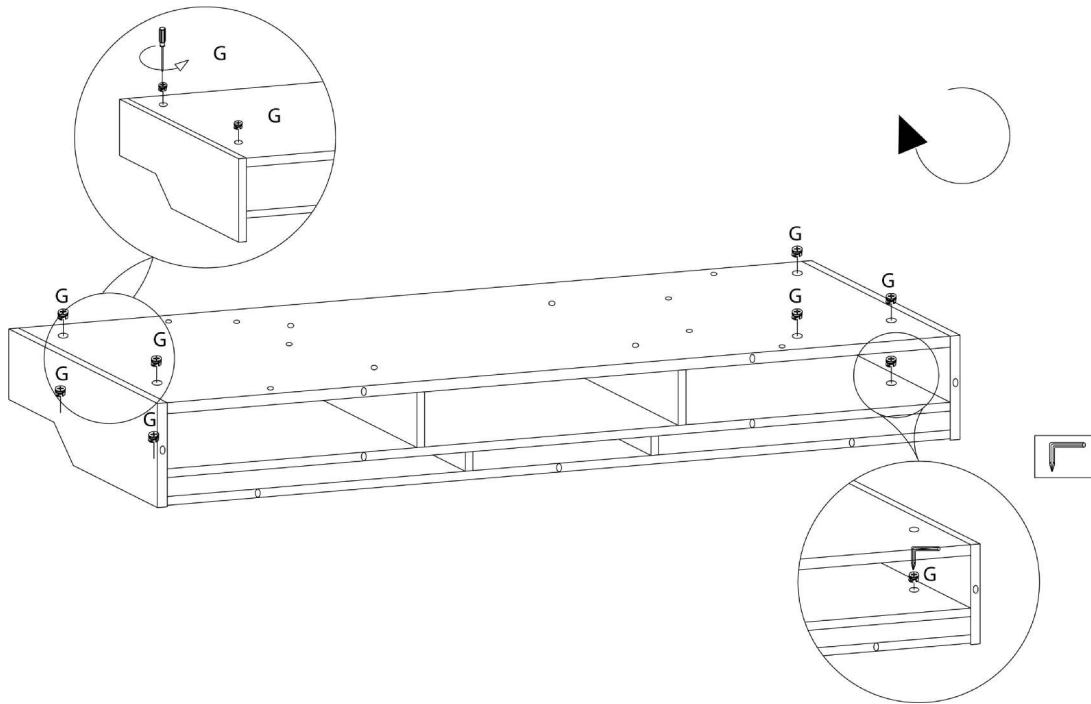

ÉTAPE / STEP 10

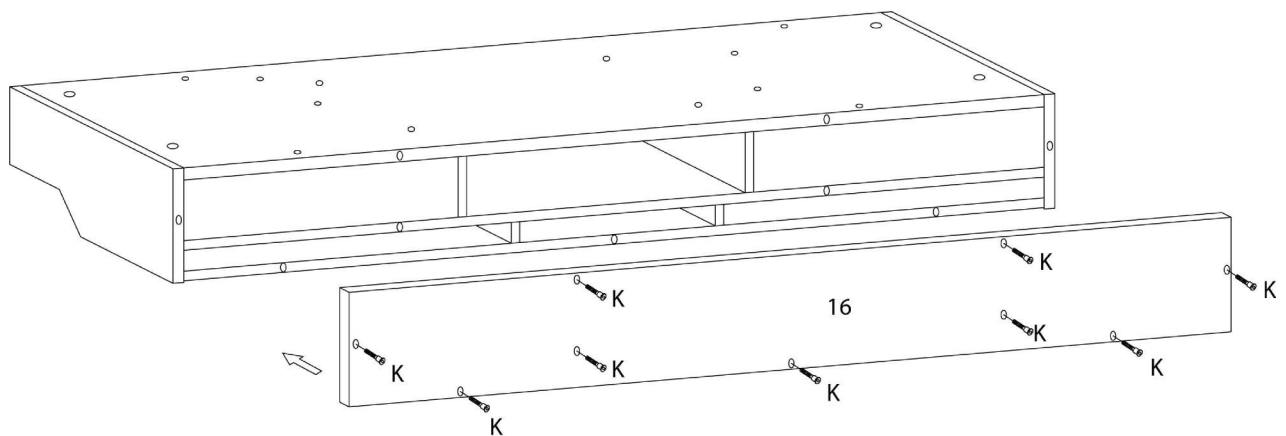

ÉTAPE / STEP 11

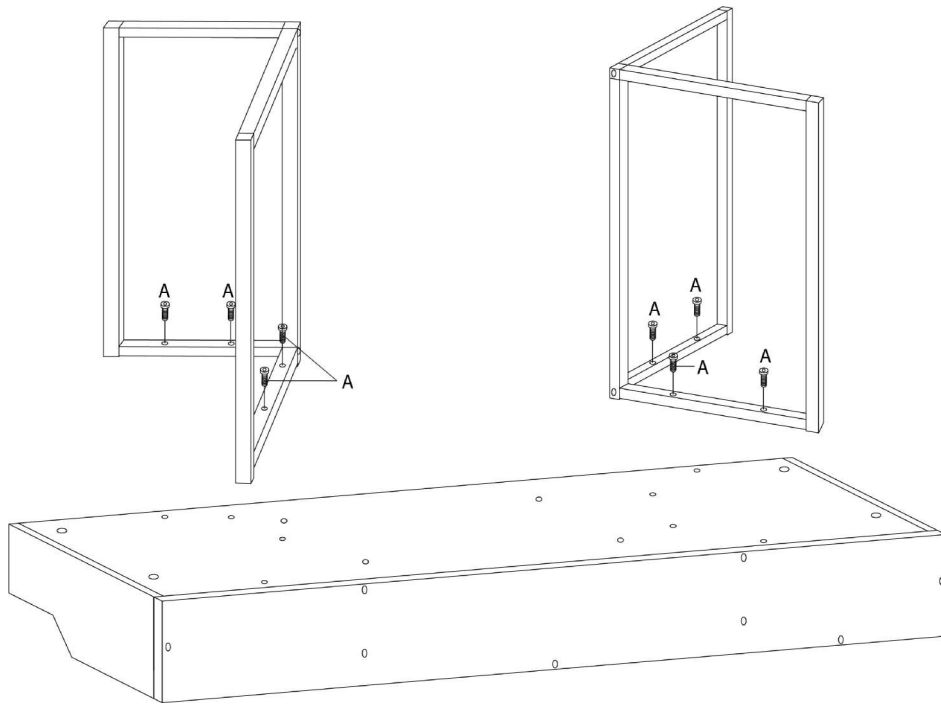

ÉTAPE / STEP 12

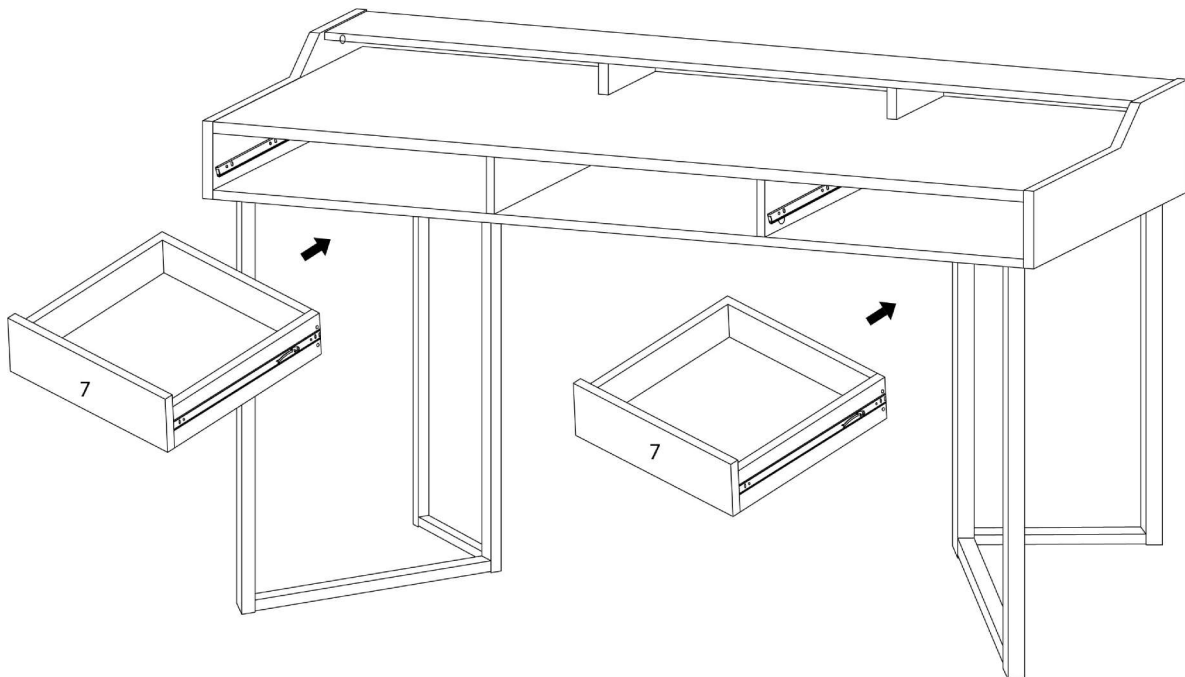

ÉTAPE / STEP 13

