

LED SECURITY WALLPACK

Catalog No. : PRWX28-H-4K-BZ

Type : Wallpack Light

Project Name :

Location :

Qty :

Date :



Probrite 28-watt integrated LED wallpack is perfect for both commercial and residential outdoor security lighting applications as the fixture has precision forward throw optics, which prevents light escaping toward the sky. The fixture itself is built to last with a die-cast aluminum construction and commercial-grade powder paint coat. The light can be mount quickly and easily on wall, with the help of mounting plate.

PRODUCT PERFORMANCE AT A GLANCE

SYSTEM WATTAGE	LUMENS	LPW	CRI	REPLACES (Incandescent)
28W	3500 lm	125 lm/w	>70	250W

HOUSING

Die cast aluminum housing with corrosion resistant powder-coated paint finish. It is designed to ensure cooling by natural convection and passive airflow, to let driver perform efficiently

IP RATING & LISTINGS

LED light engine is weather proof and rated as IP65, UL Listed, and DLC standard

OPTICS

Prismatic polycarbonate lens, provides wide and even light coverage without visible "hot-spots" on the lens and gives superior lighting experience.

MOUNTING

It can be mount on wall with the wall mount plate.

FINISH

Fade, weather, and abrasion resistant, electrostatically applied, thermally cured, triglycidal isocyanurate (TGIC) textured polyester powdercoat bronze paint finish.

WARRANTY

Covered by a 5-year limited warranty. See probrite.com/warranty for details.

PRODUCT SPECIFICATION

Product Dimensions	: 9.44" x 6.09" x 4.31"
Weight	: 2.42 lbs
Lumens	: 3500
LED Wattage	: 28W
Efficacy	: 125W
CRI	: >70
Replaces (Incandescent)	: 250W
Mounting	: Wall Mount
Frequency	: 50-60Hz
THD (Total Harmonic Distortion)	: <20%
PF(Power Factor)	: >0.9
Ambient Operating Temperature	: (-30)-40°C
Input Voltage	: 120-277V
LED Chip	: -
Photocell	: No
Driver	: Non-Dimming
Standard Lifetime	: 50,000 hrs
Standard Warranty	: 5 Years
Water Proofing Grade	: Suitable for wet location
CCT	: 4000K Bright White Light
Certifications	: IP 65, Energy Star, FCC Certified, UL Certified, DLC Standard

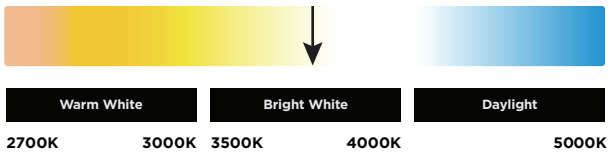

PRODUCT LINE DRAWING

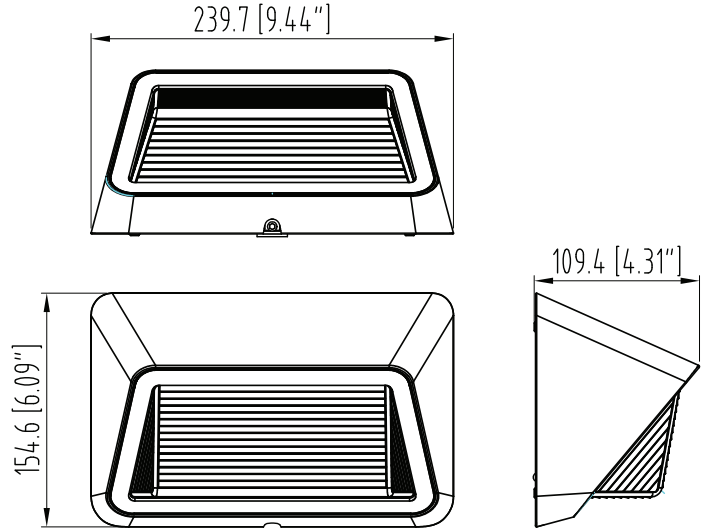

APPLICATION

SUITABLE FOR MULTIPLE APPLICATIONS

WAREHOUSES • LOADING BAYS • PATIOS
• COMMERCIAL PARKS • APARTMENT COMPLEXES

SUGGESTED MOUNTING HEIGHT:
6-12 FT.(1.8-3.7 M)

3D PHOTOMETRIC VIEW

