

Installation Instruction

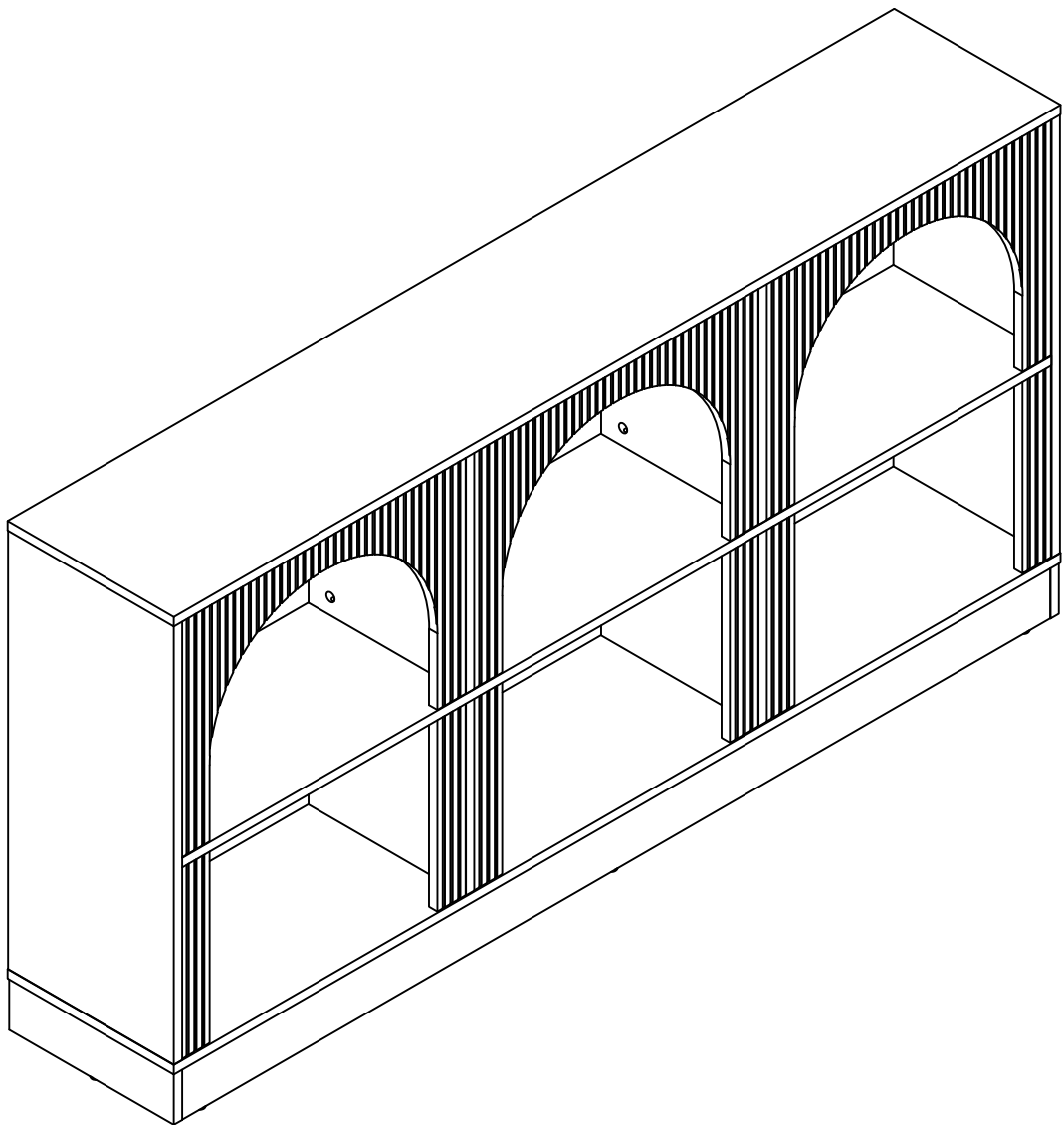

Assembling

What you need

- Use the packaging carton as a working surface to prevent product damage during assembly
- Phillips head screwdriver

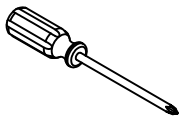

Weight Limitation

 **100** | **35**
lbs table top lbs per

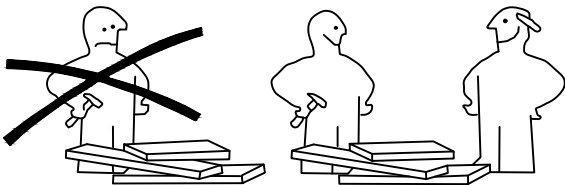

What' included

Code	Description	Qty
A	Cam Bolt M6X35MM	64
B	Cam Lock 15X10MM	64
C	Wooden Dowel M8X30MM	24
D	Screw M4X40MM	10
E	Screw M3.5X14MM	16
F	Self-adhesive hole sticker	64
G	Metal connector	2
H	Wooden Dowel M8X50MM	10
I	MATS	8
J	The back button	14
K	Anchor	2

The Hardwares

Ⓐ

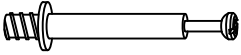

Ⓑ

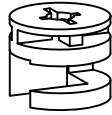

Ⓒ

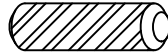

Ⓓ

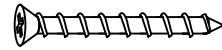

Ⓔ



Ⓕ



Ⓖ

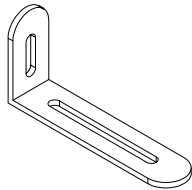

Ⓗ

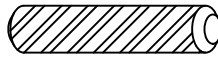

Ⓘ



⓵

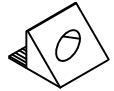

Ⓚ



IMPORTANT:

1. Do not tighten bolts / screws completely until all bolts / screws are lined up and inserted into holes.
2. Do not over tighten screws and bolts to avoid stripping
3. You can use a screwdriver. Power tools can also be used. (Be careful with power tools)

Included Accessories

Code	Description	Qty
1	Cabinet Top	1
2	Bottom Panel	1
3	Left Side Panel	1
4	Right Side Panel	1
5	On the rear panell	1
6	Upper partition	2
7	Lower partition	2
8	On the rear panell	1
9	laminate	1
10	Top trim	3
11	Bottom trim	6
12	Foot left and right connecting plate	2
13	Foot front and rear connecting plates	2

The Accessoriess

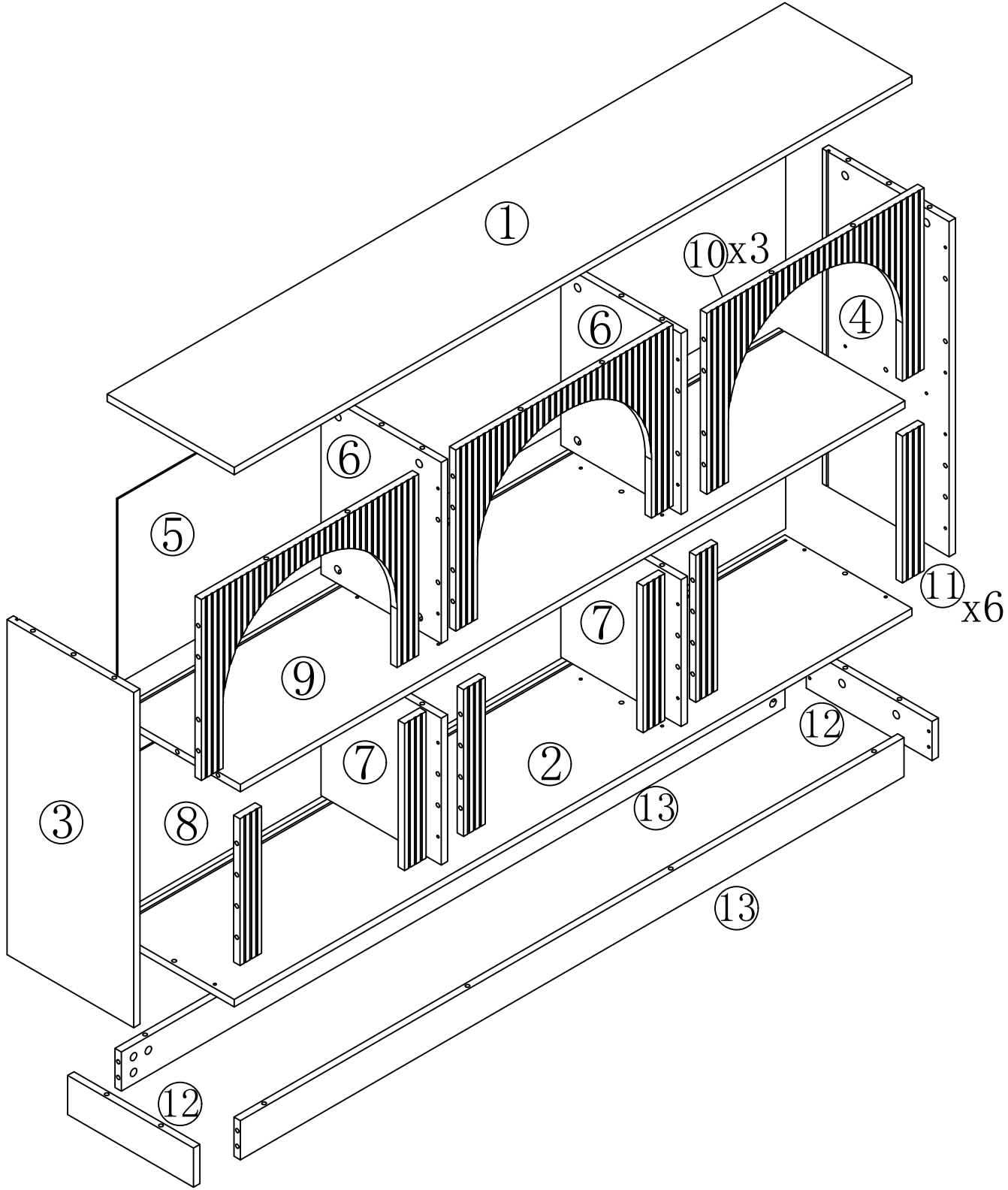

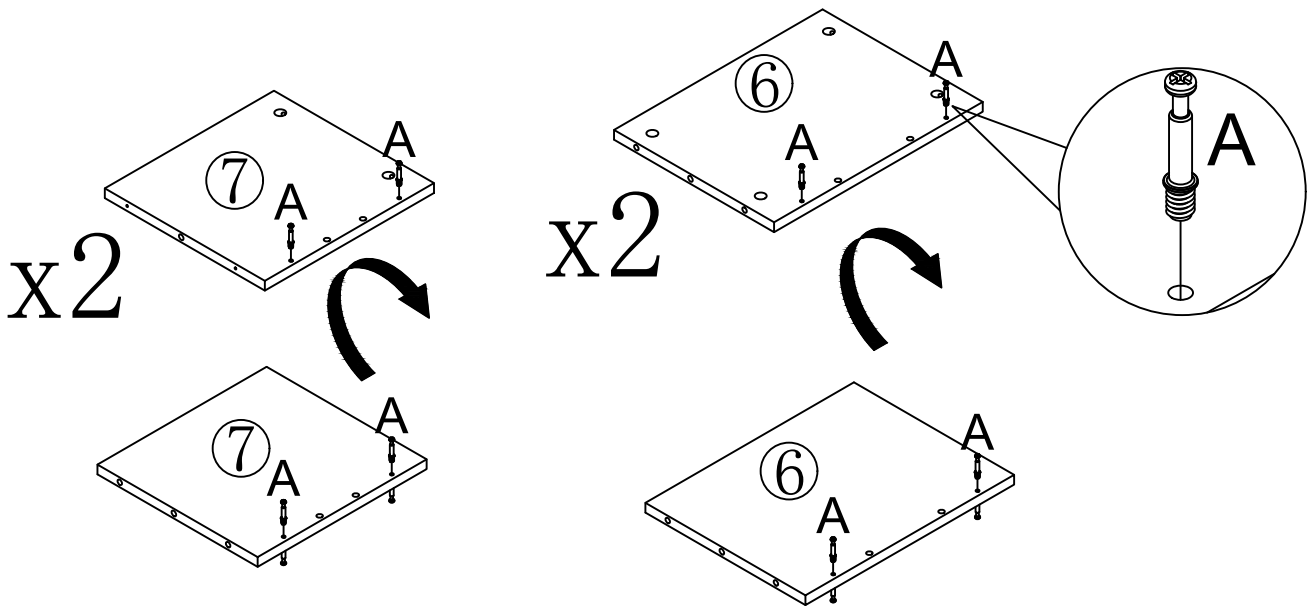
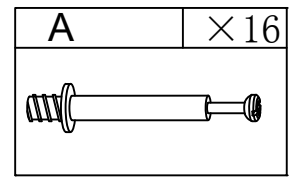

Step 1

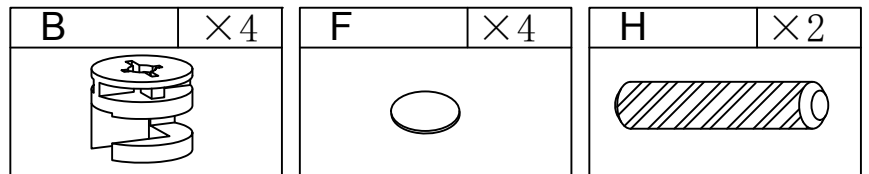

Step 2

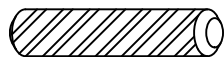

Step 3

B	×4	F	×4	H	×2
					

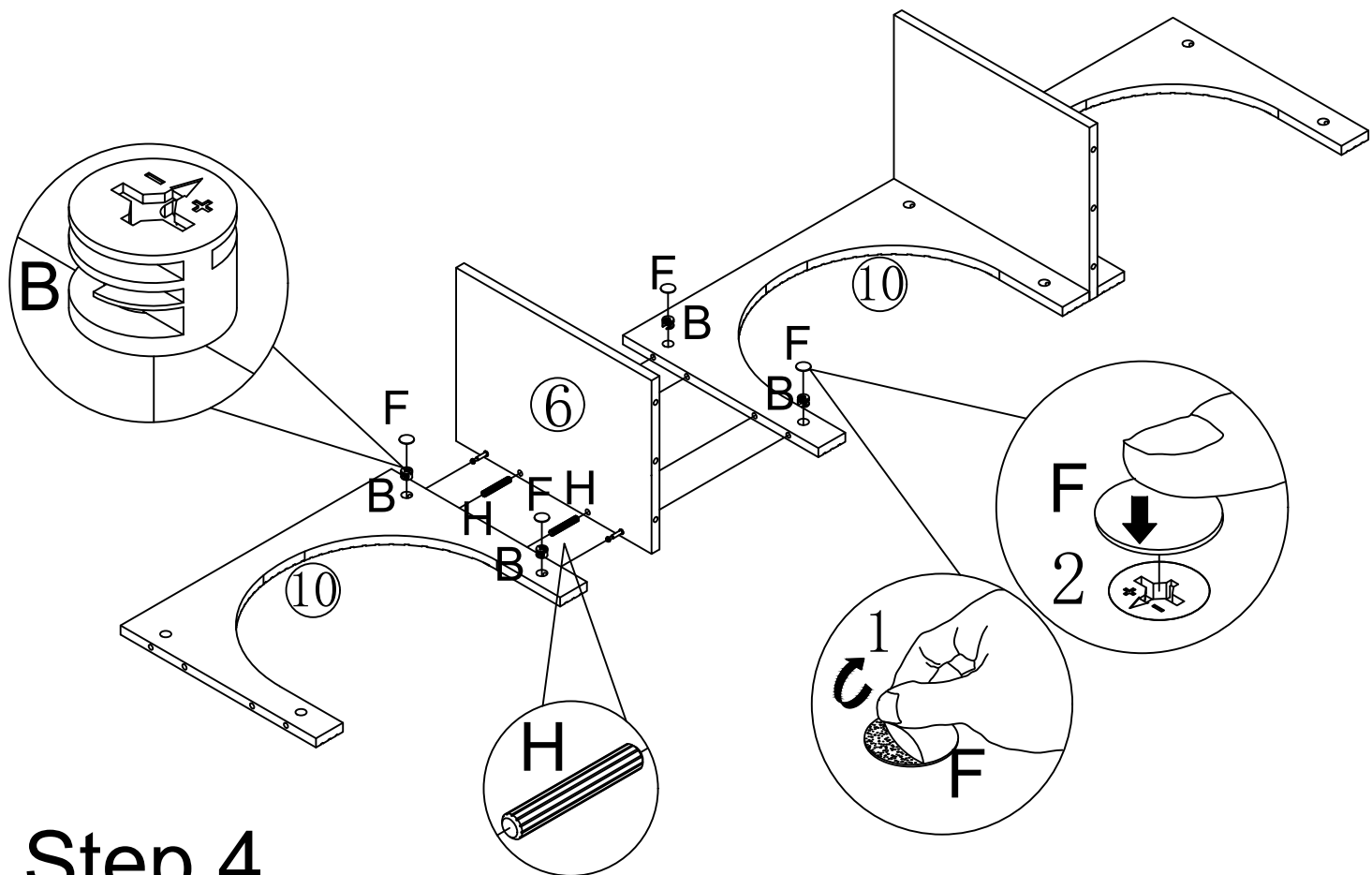

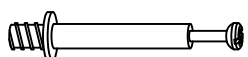

Step 4

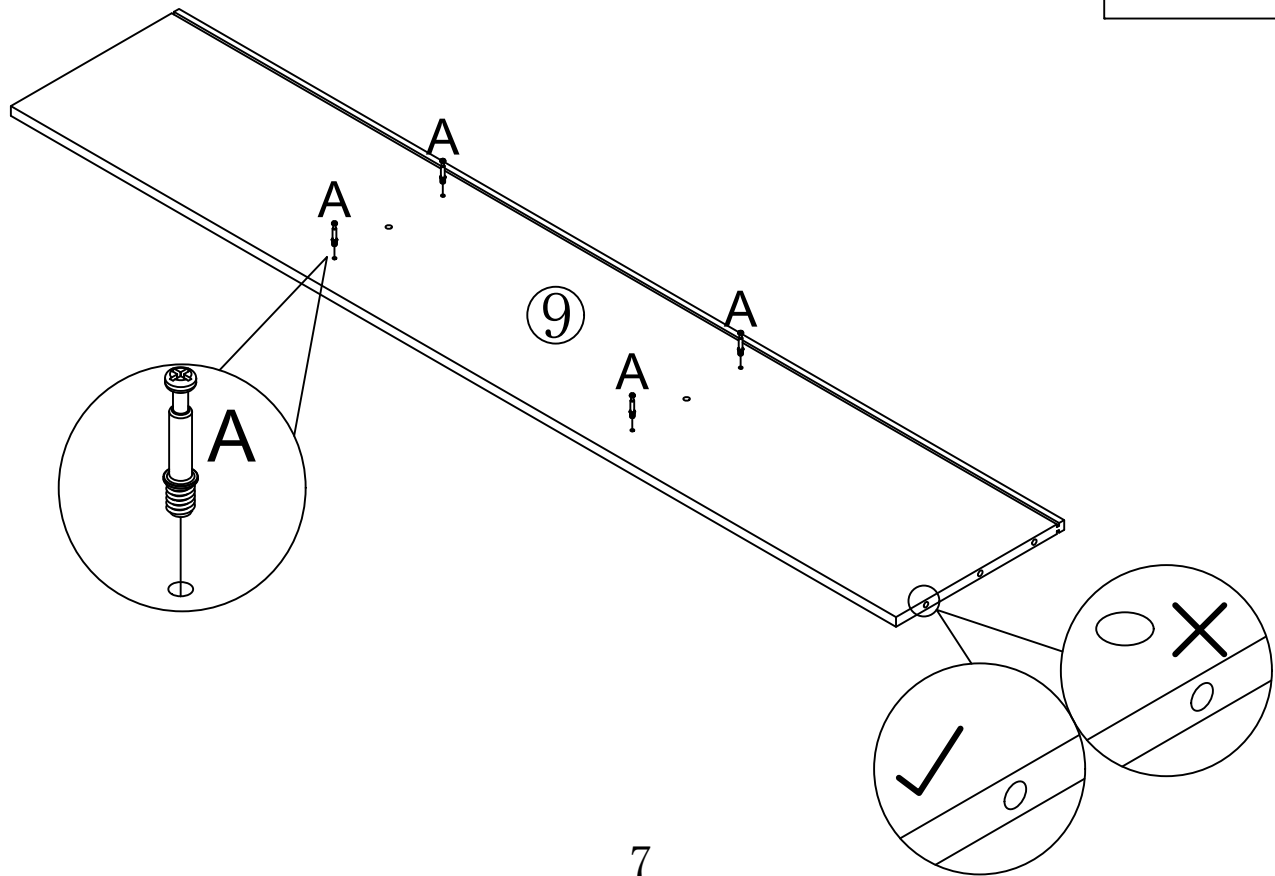
A	×4
	

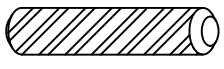

Step 5

B	×4	F	×4	H	×2
					

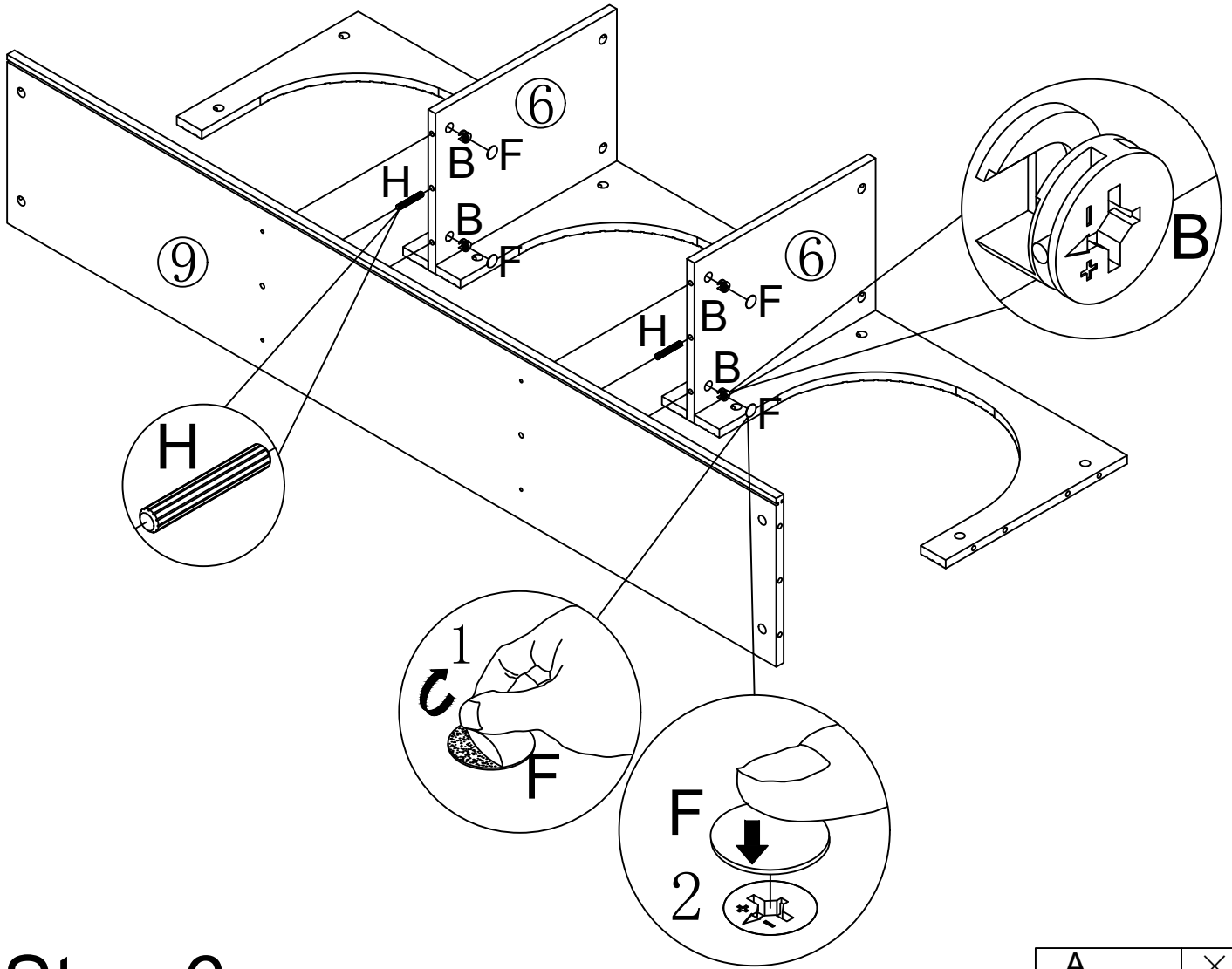

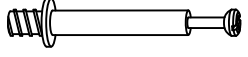

Step 6

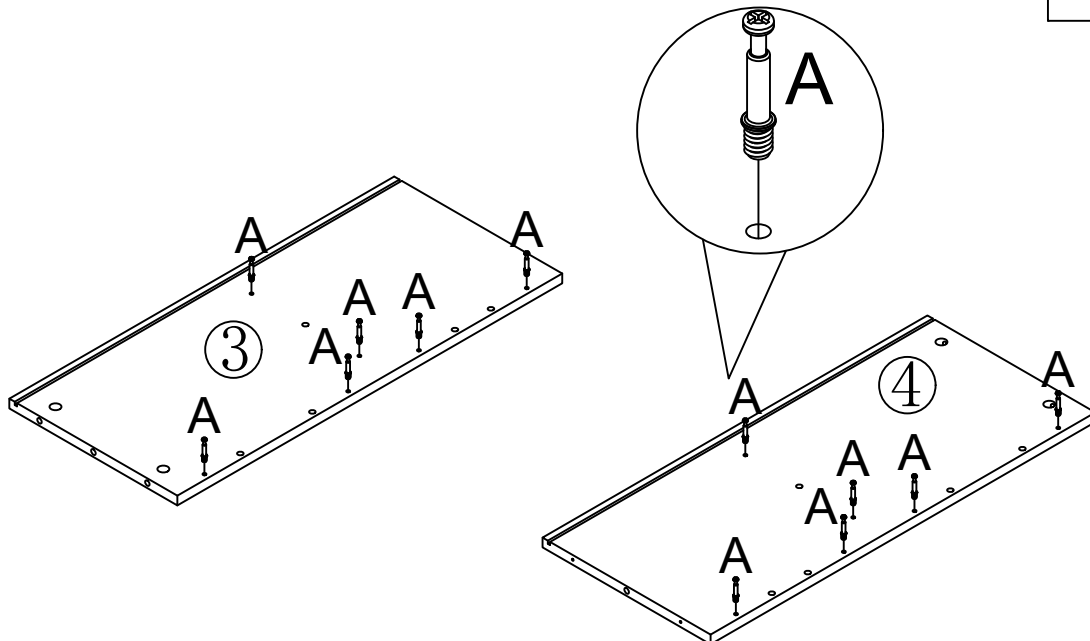
A	×12
	



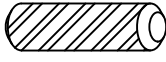

Step 7

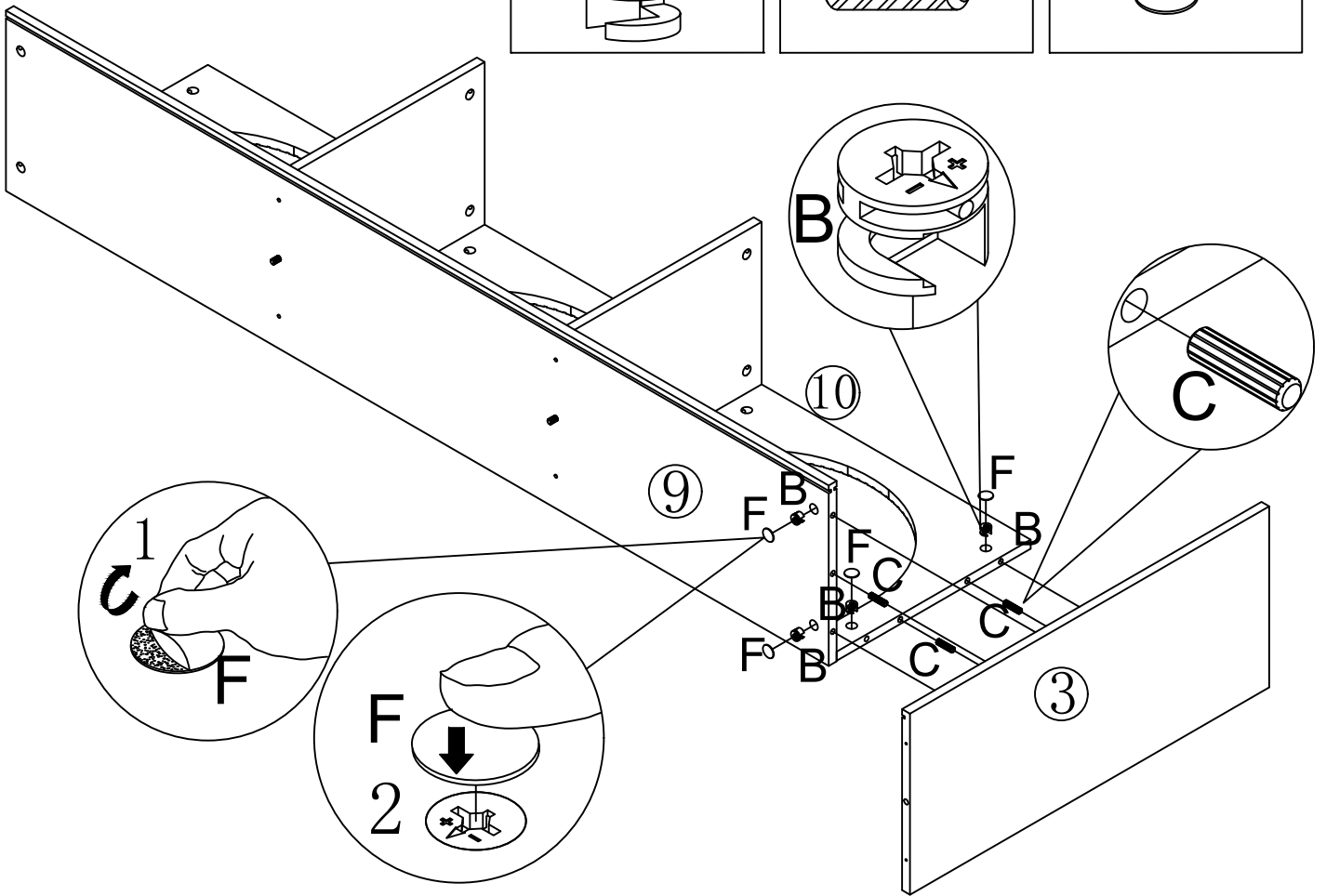
B	×4	C	×3	F	×4
					

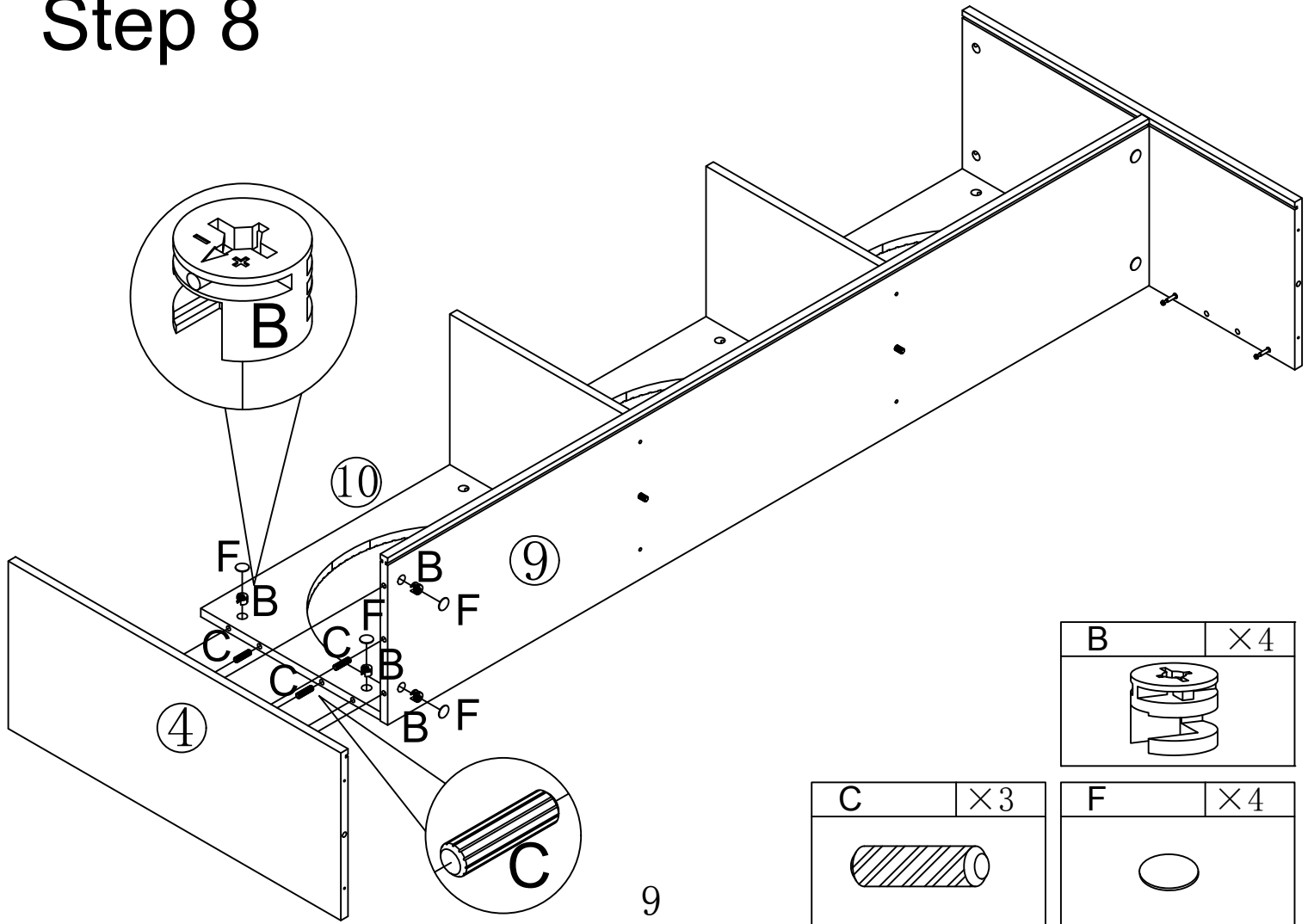

Step 8

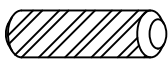

B	×4
	

C	×3
	

F	×4
	

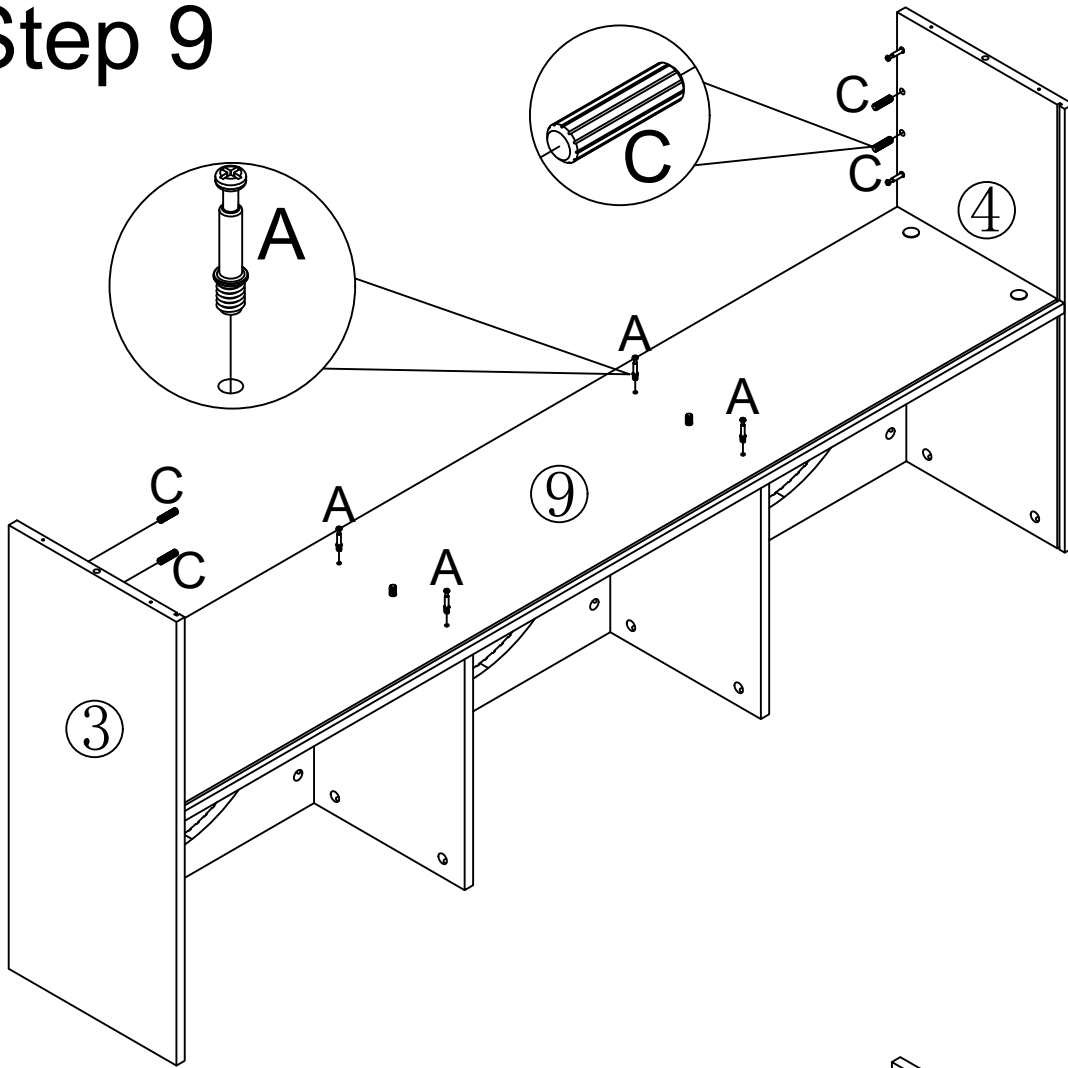

Step 9

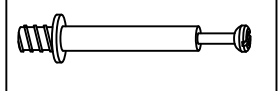
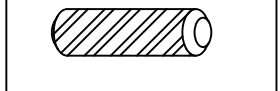

A	×4
	
C	×4
	

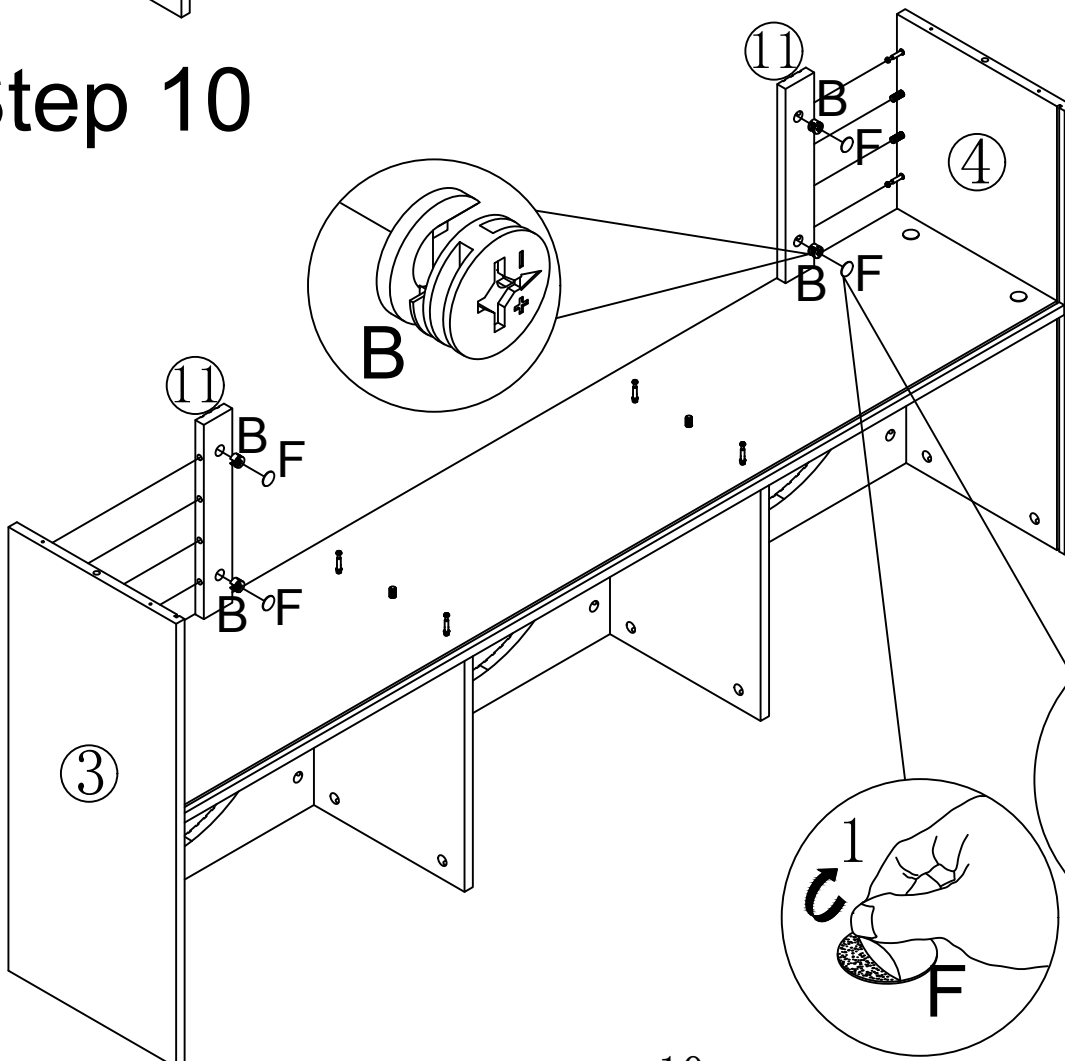
Step 10



B	×4
	
F	×4
	

Step 11

B	×8	F	×8	H	×4
---	----	---	----	---	----

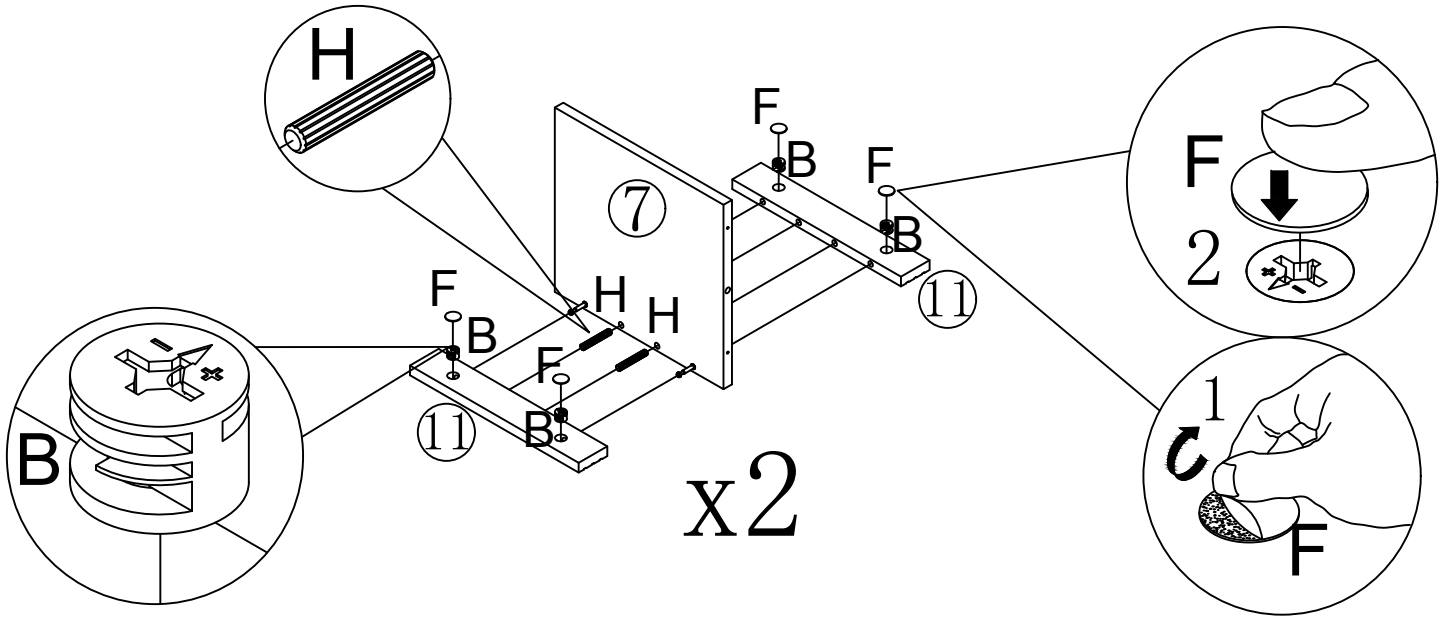

Step 12

B	×4	F	×4
---	----	---	----

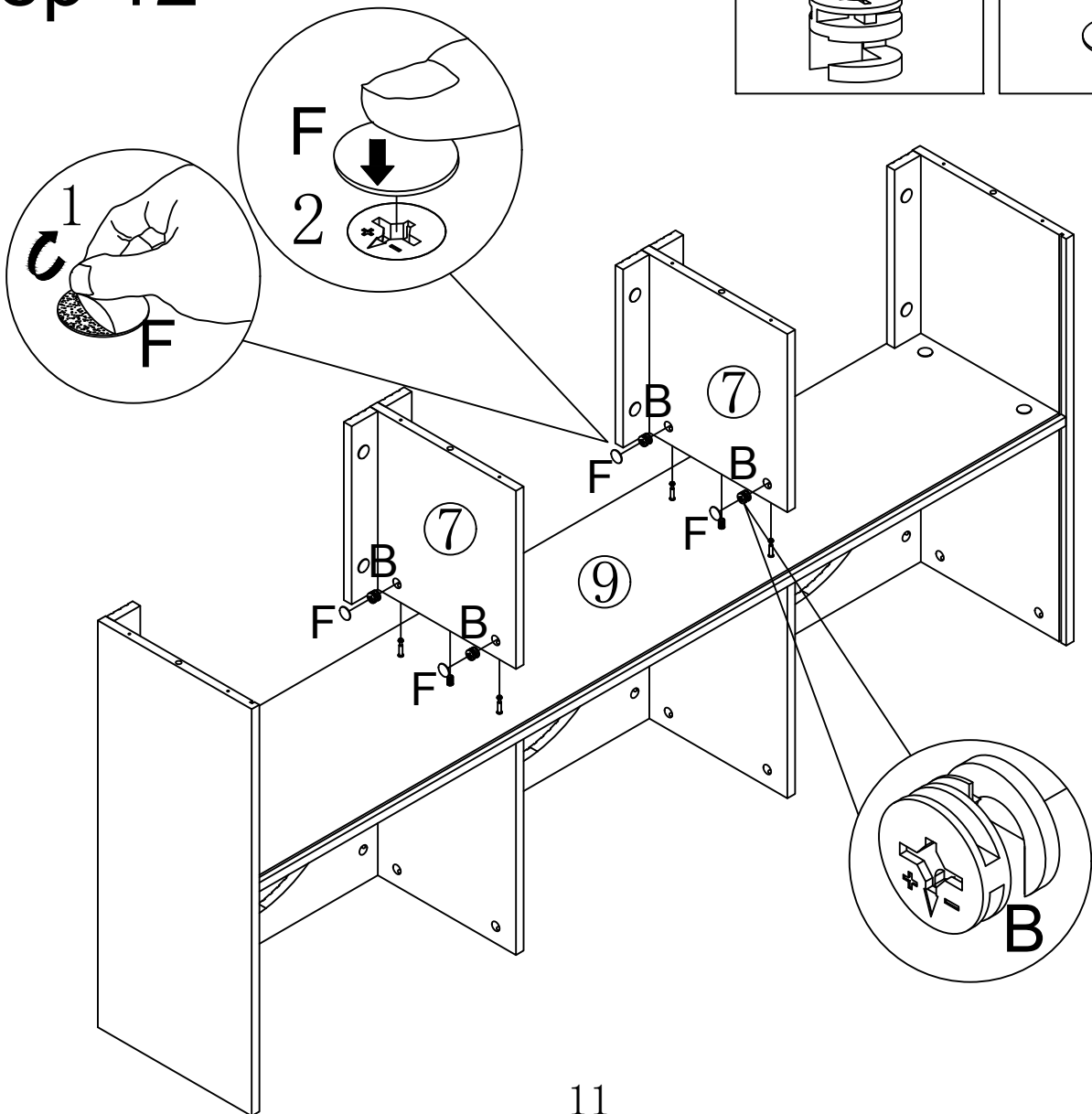

Step 13

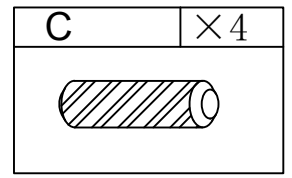
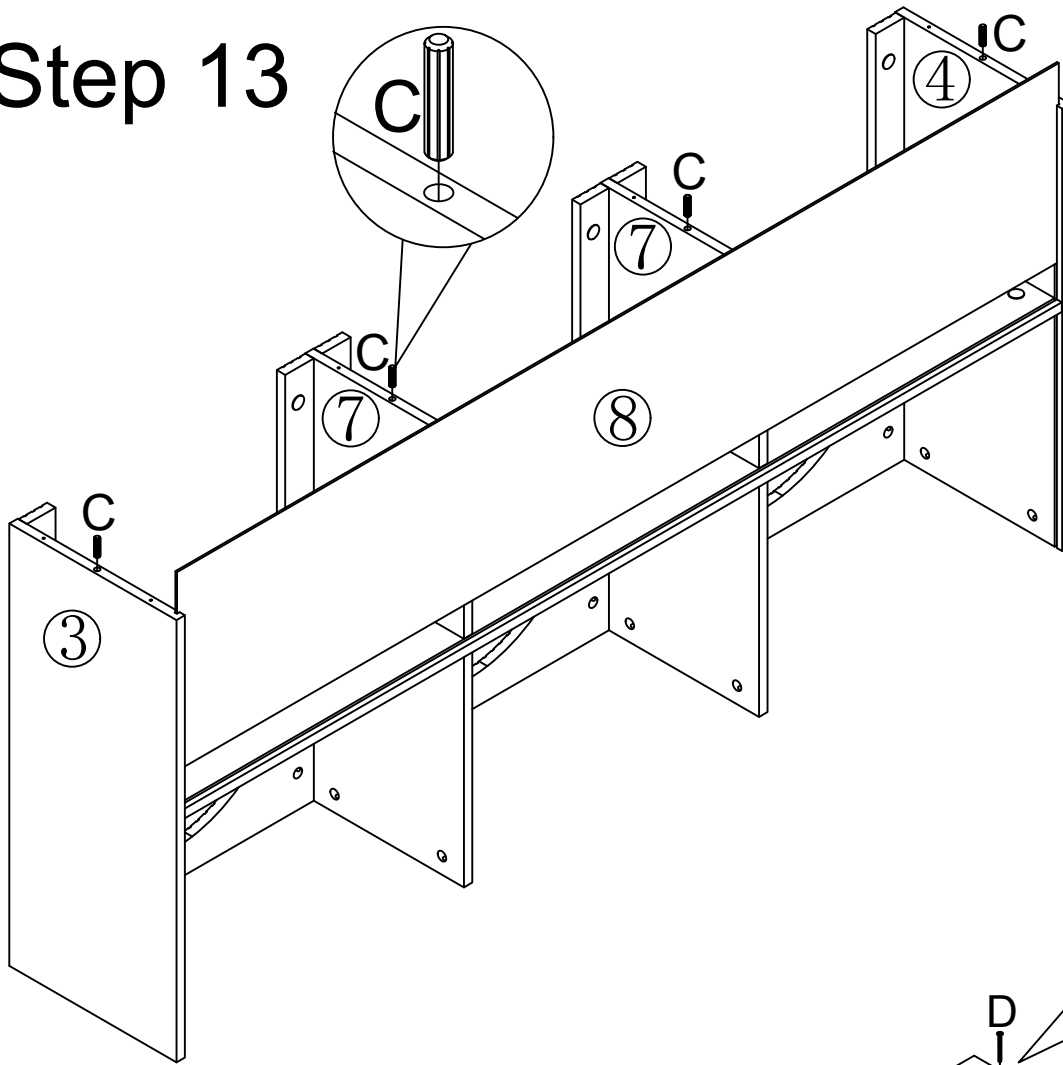

Step 14

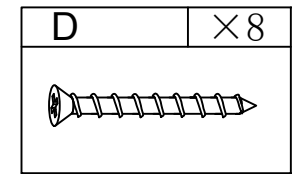
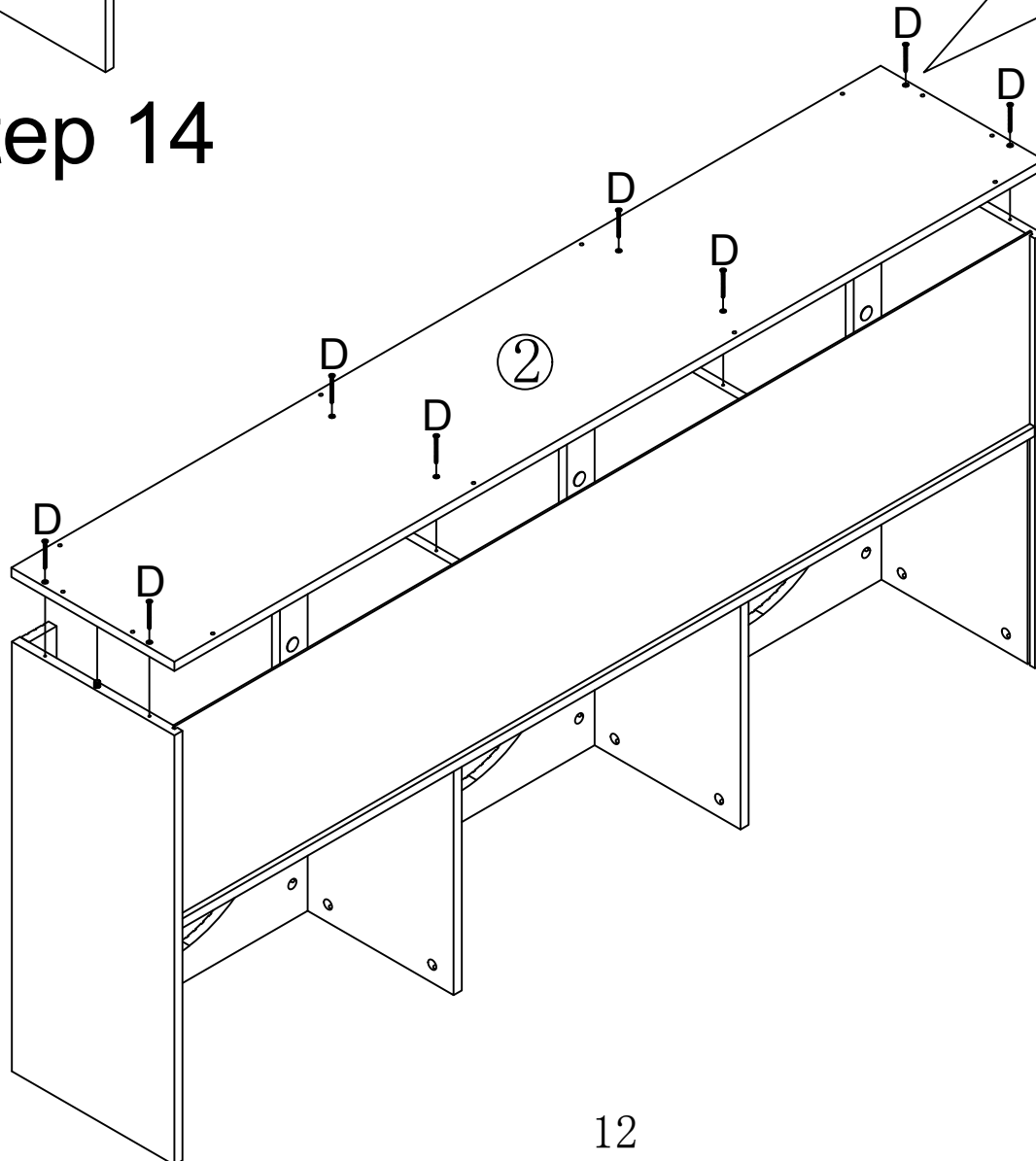

Step 15

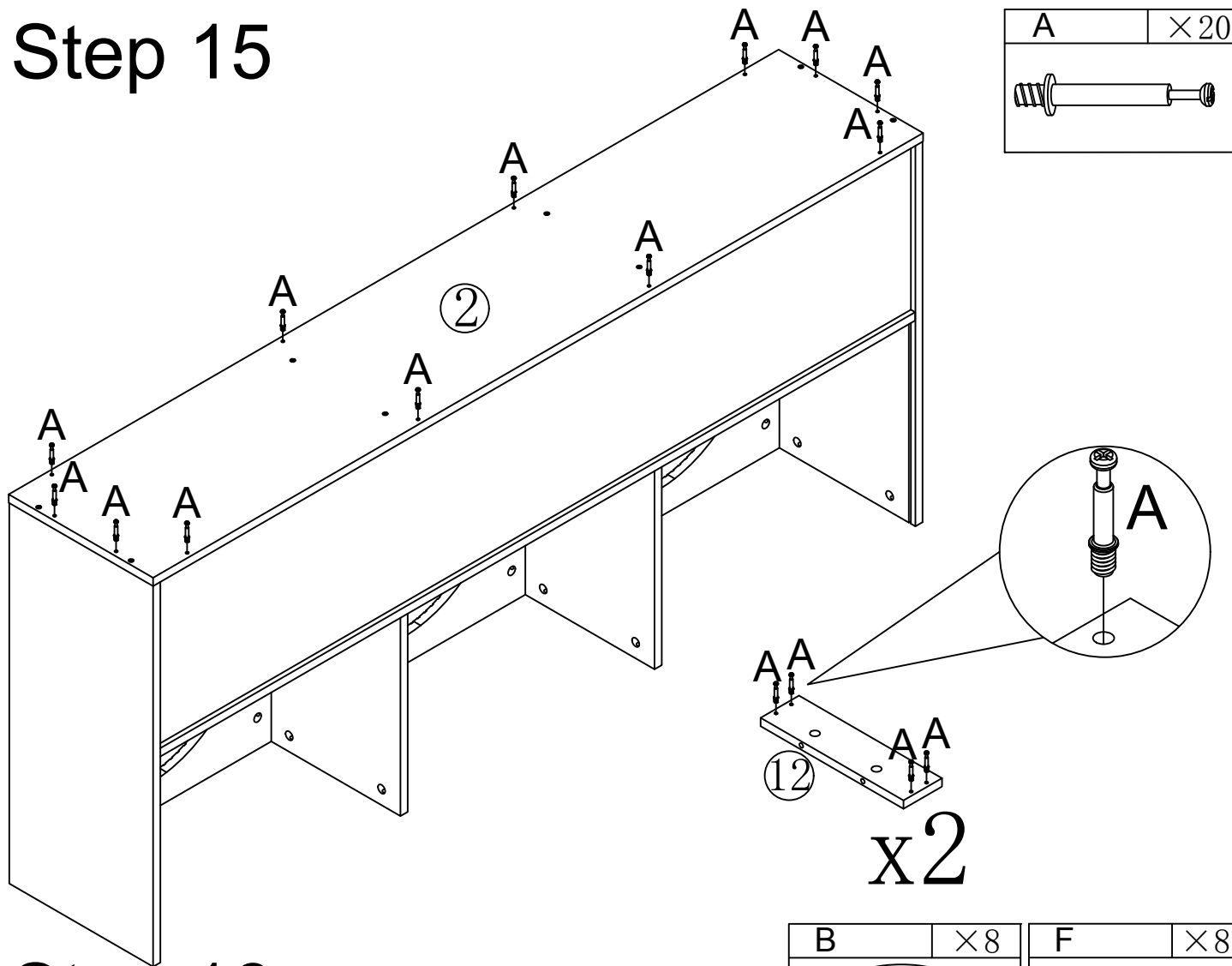

Step 16

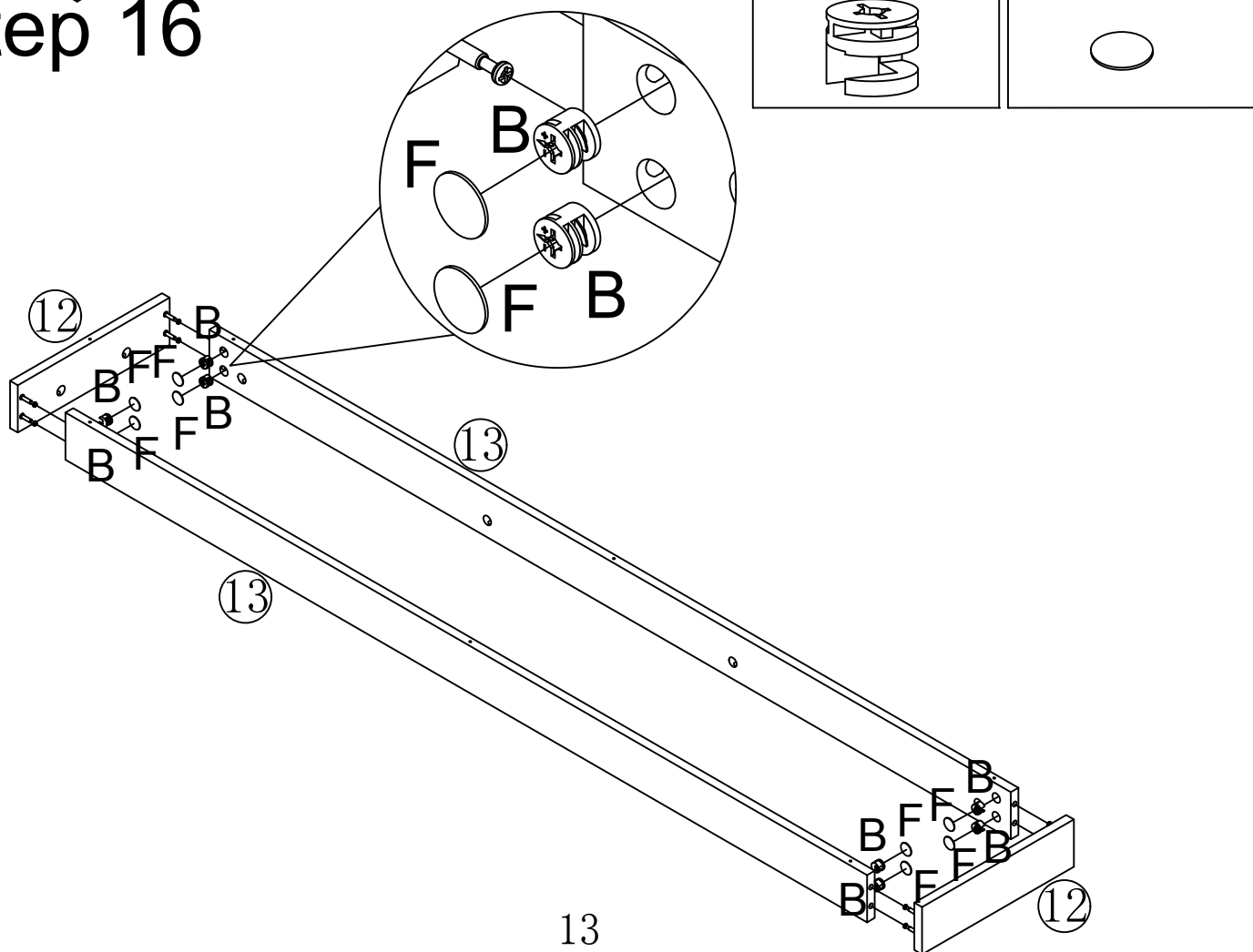

Step 17

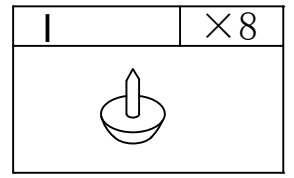
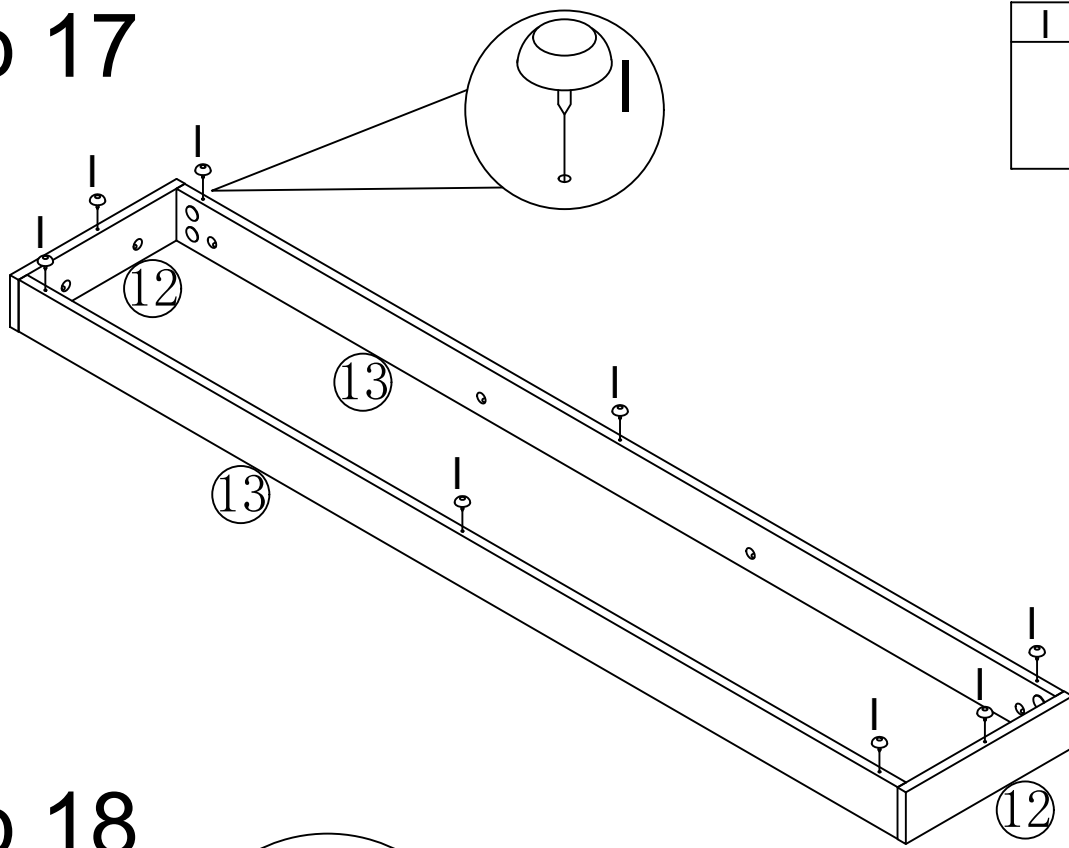

Step 18

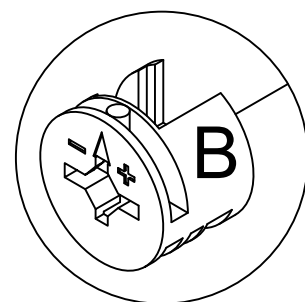
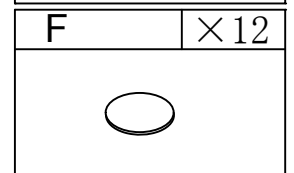
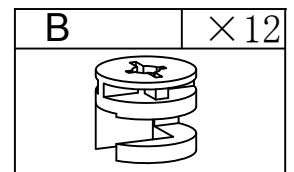
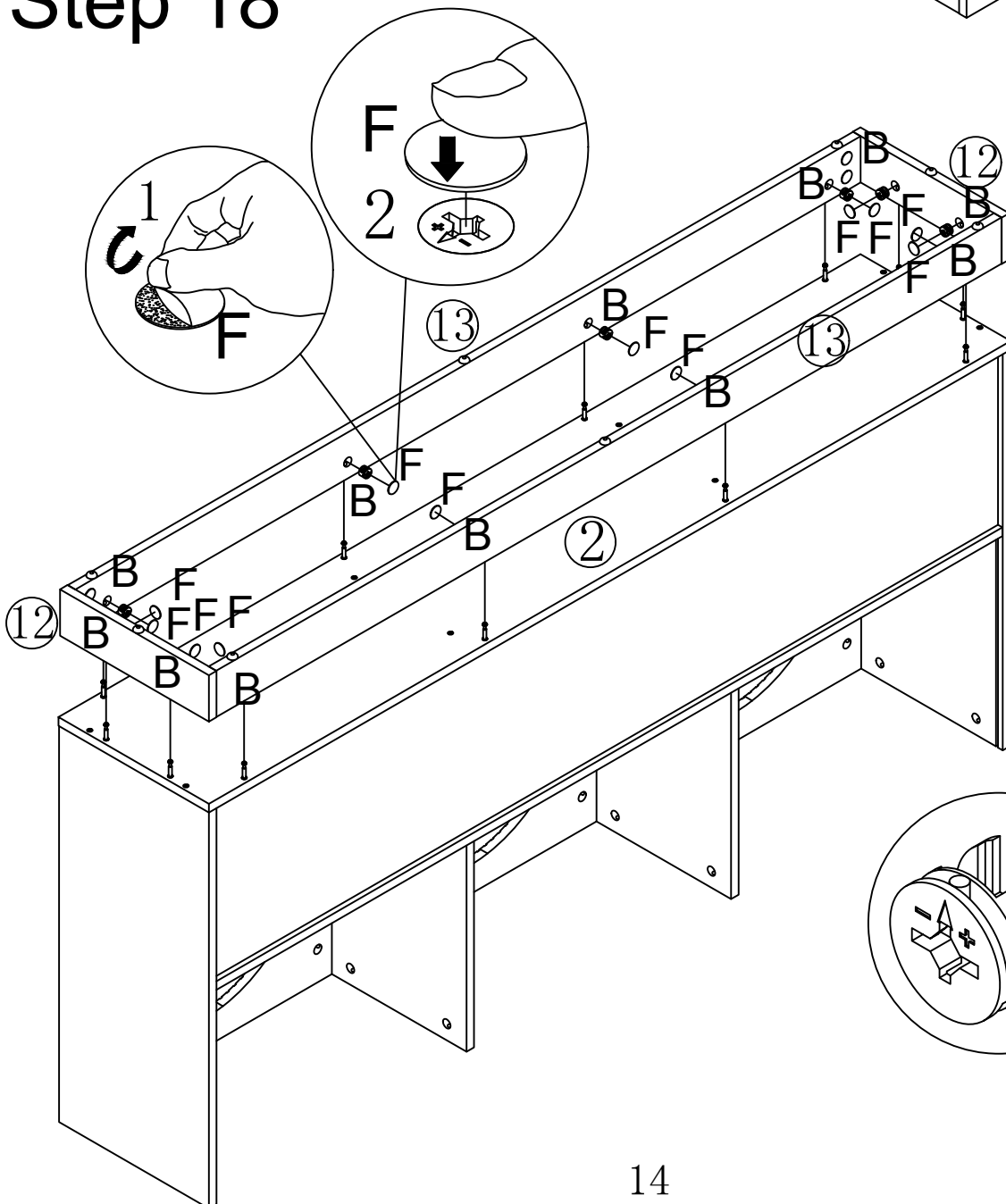

Step 19

C | ×10

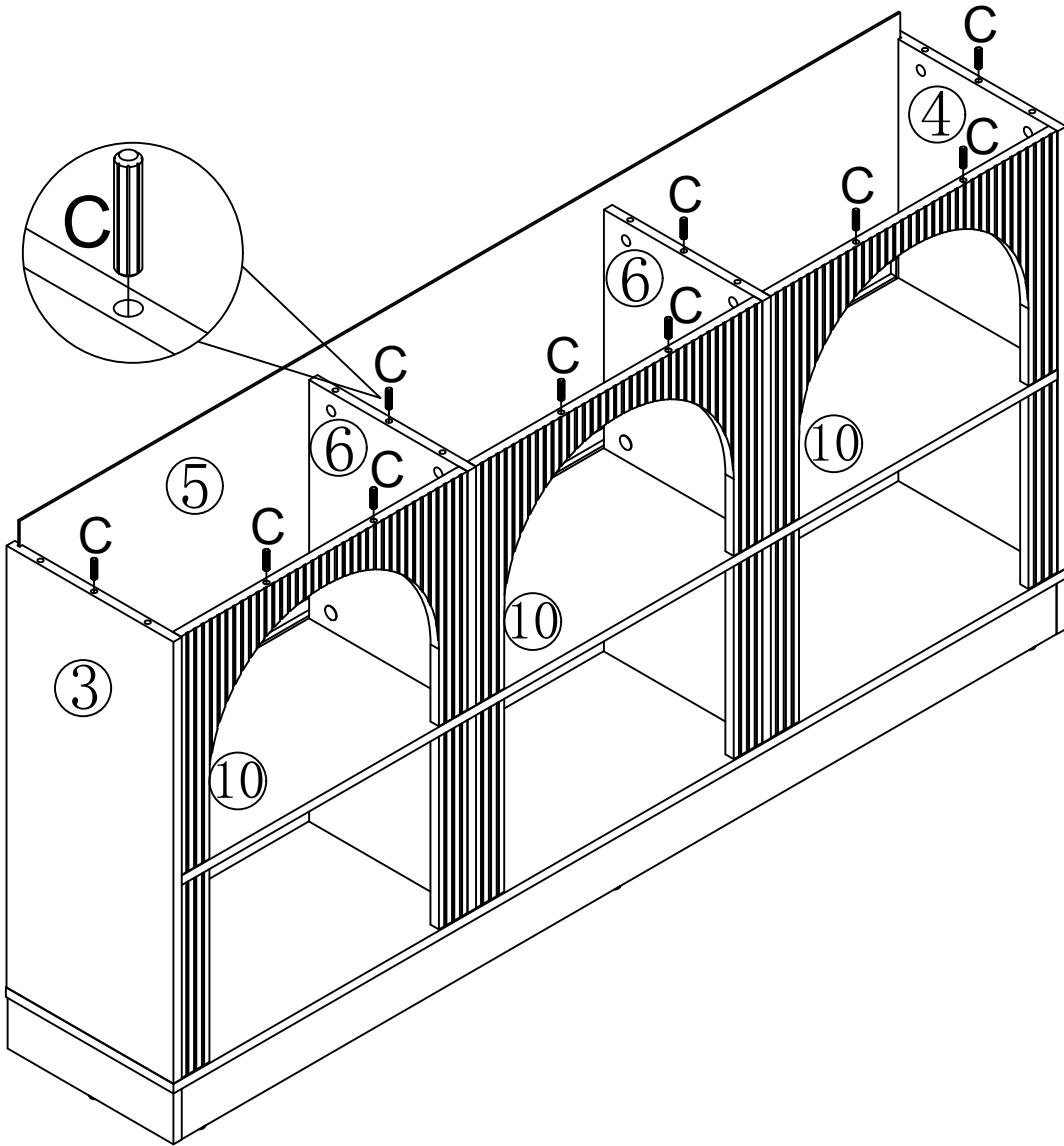
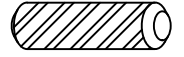

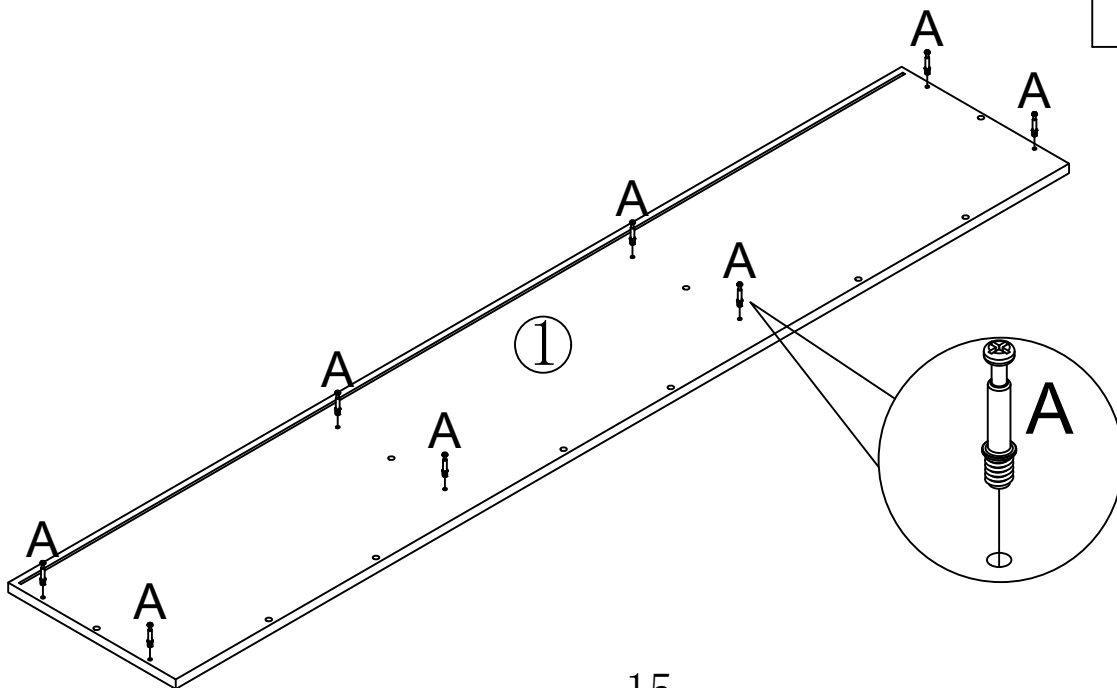
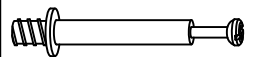

Step 20

A | ×8



Step 21

B	×8	F	×8
			

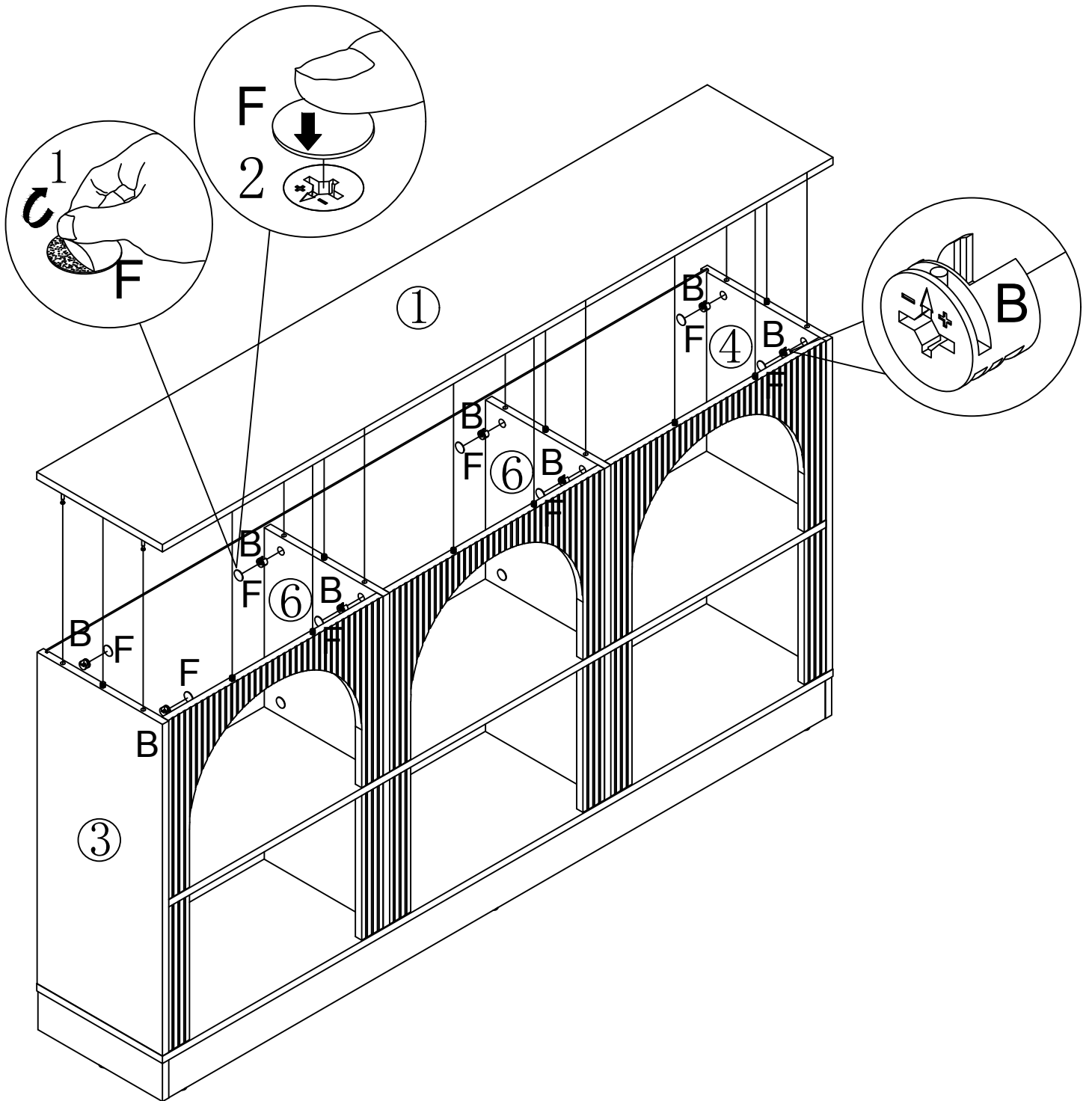

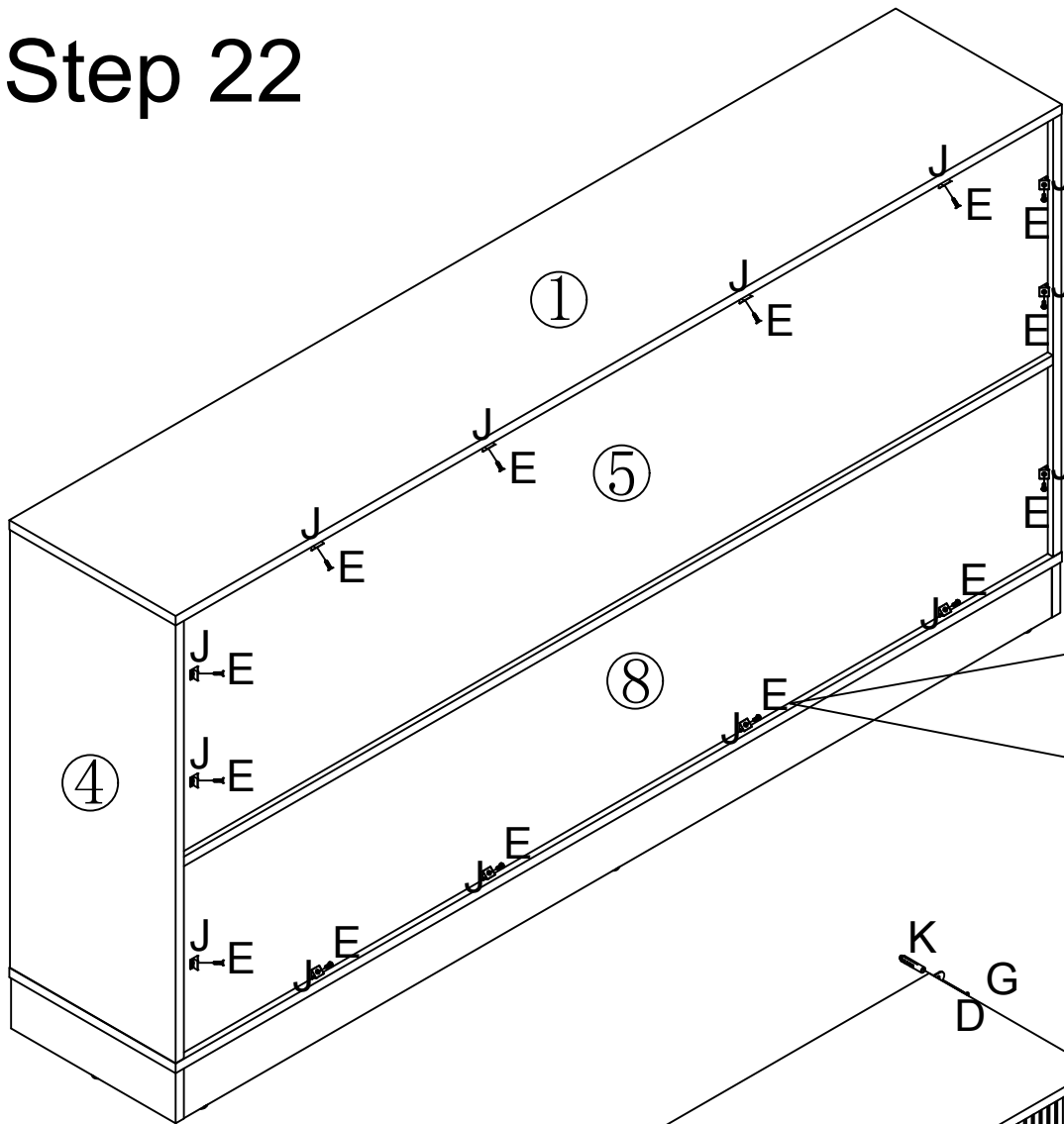

Step 22

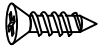
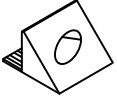

E	×14
	
J	×14
	

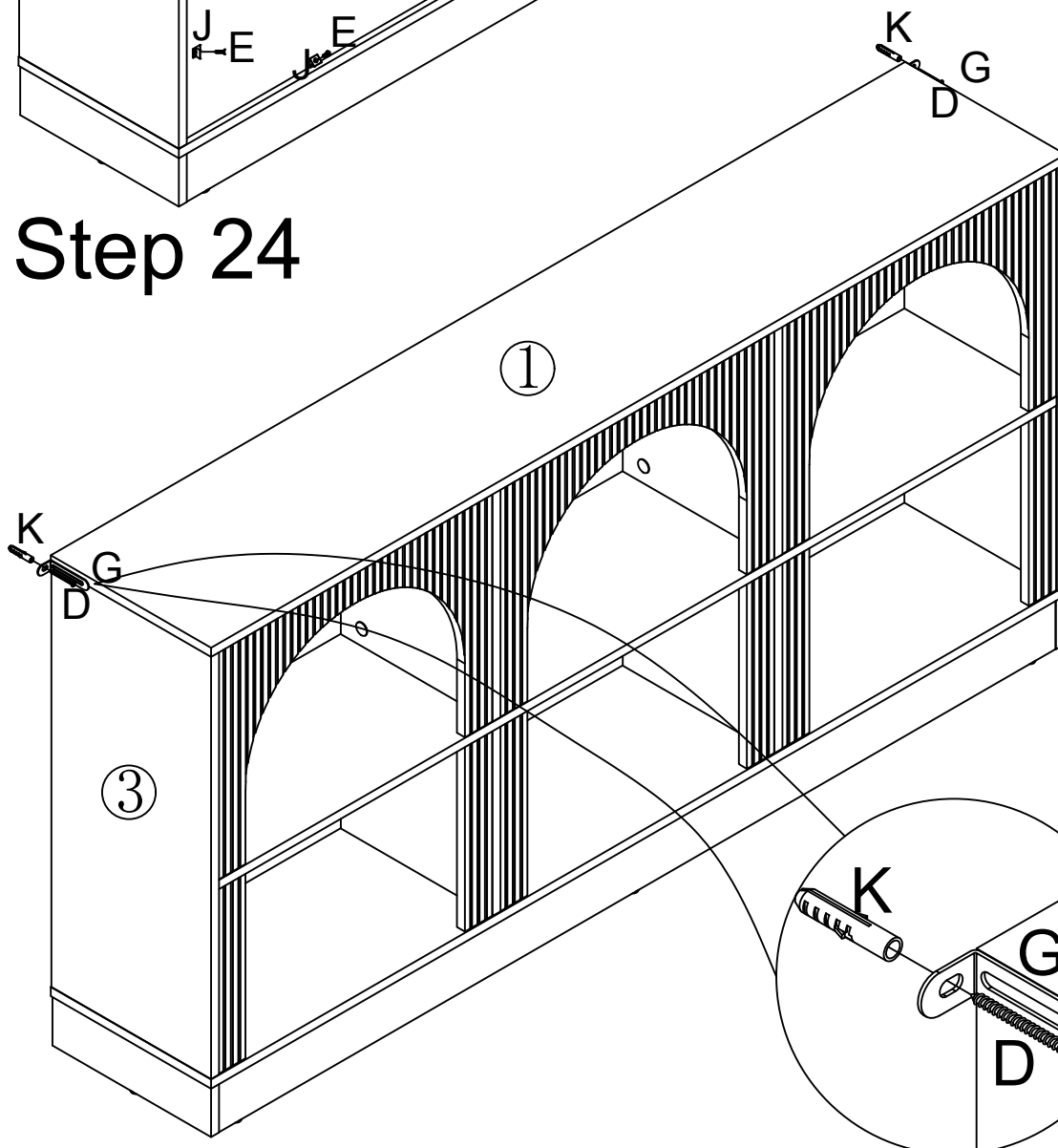
Step 24

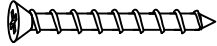
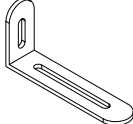

D	×2
	
G	×2
	
K	×2
	

Step 24

E	×2
