

BED FRAME

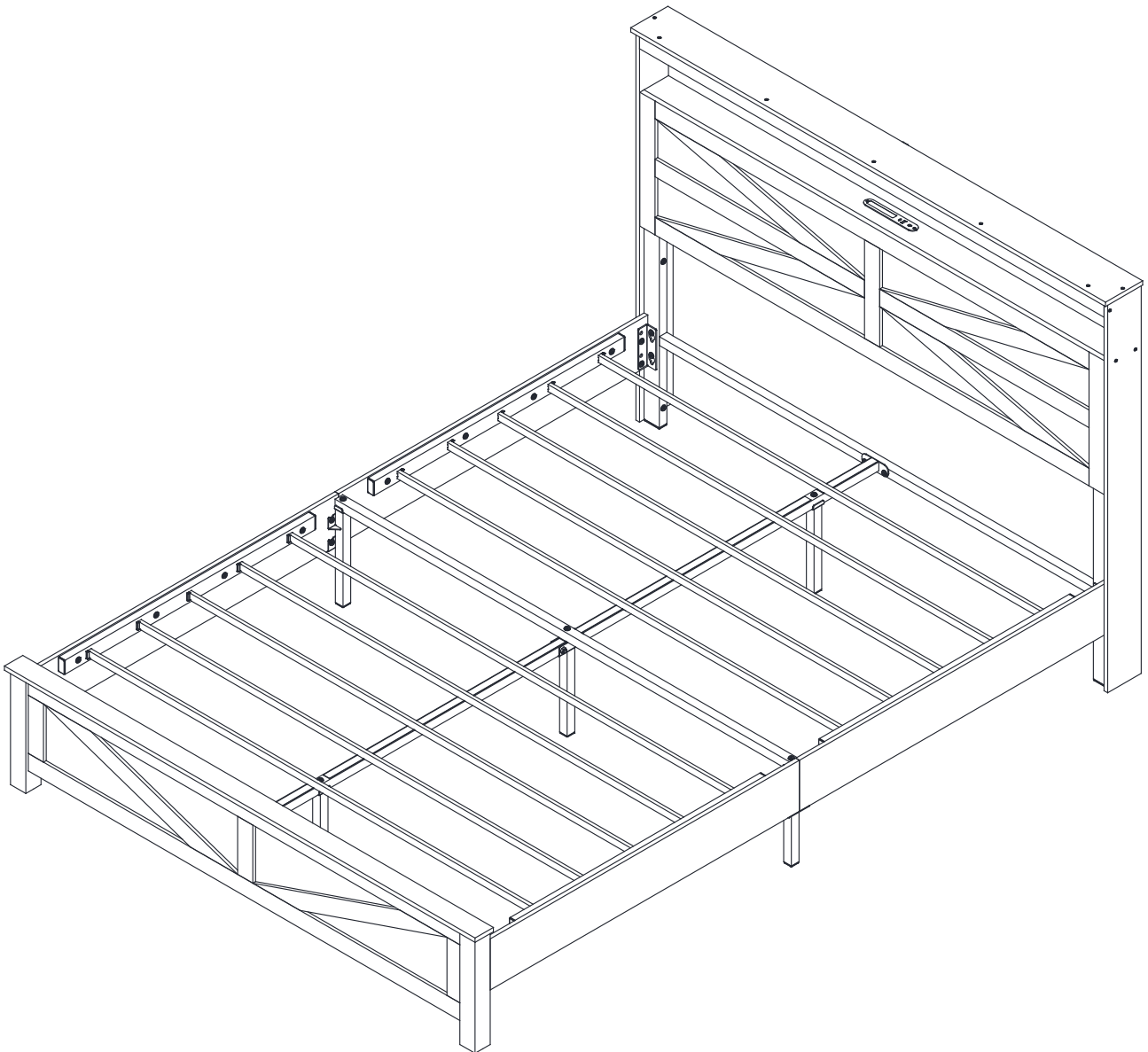

Thank you for choosing our products, please assemble and use it following the instructions.

Assembly Instruction

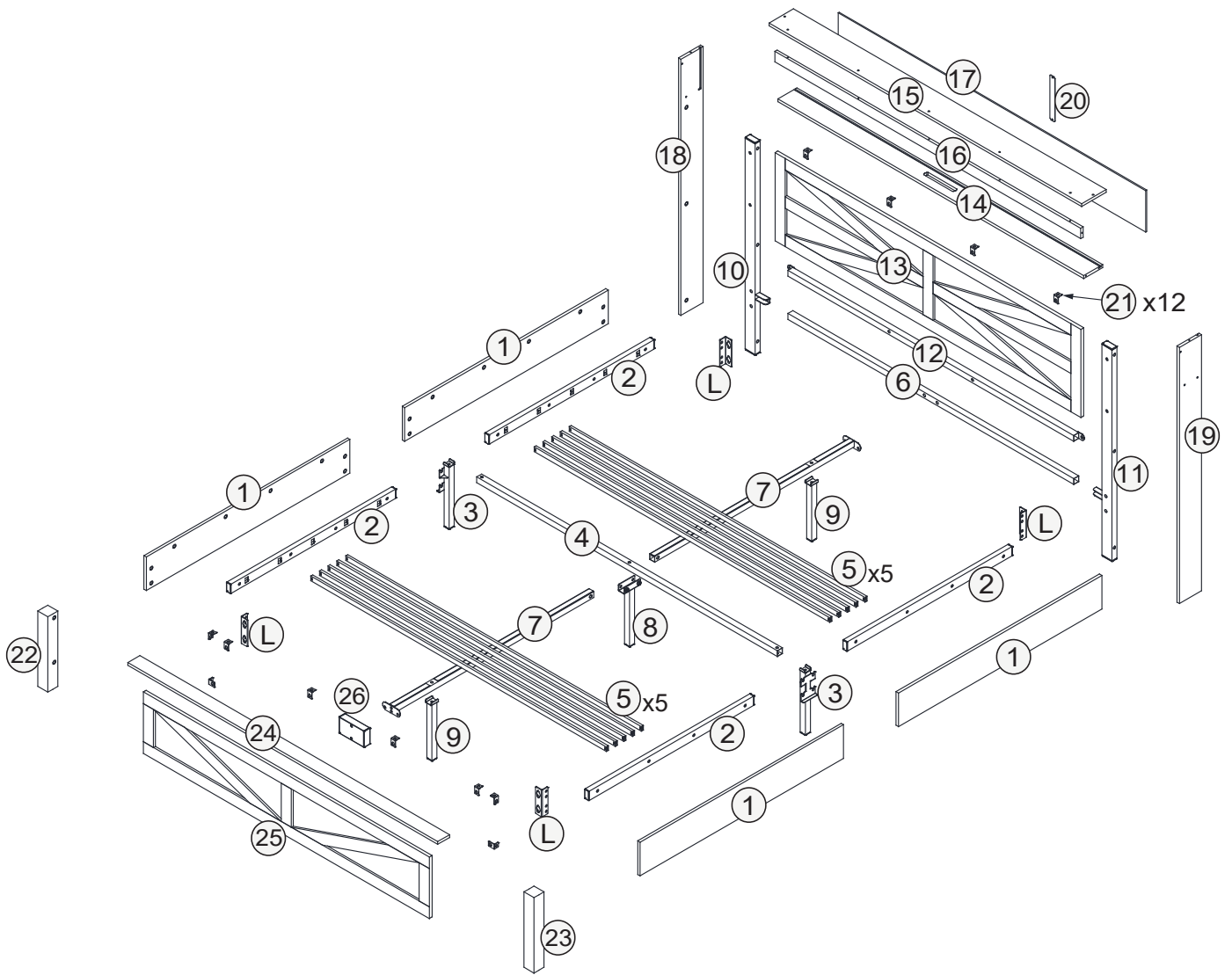

B430-F/Q/K

Important Note

HARDWARE NOTE :

1. Two or more people are required for assembly
2. Do not screw on the bolts too tight unless the installation is done. Make sure all bolts are tightly screwed before you use it.

Components

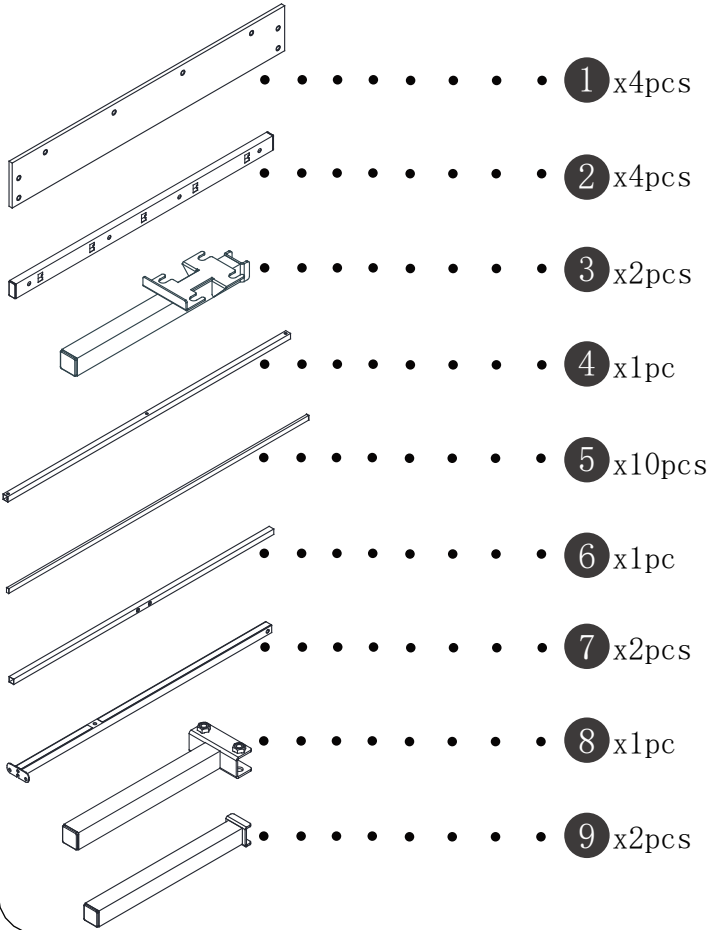

1 x4pcs

2 x4pcs

3 x2pcs

4 x1pc

5 x10pcs

6 x1pc

7 x2pcs

8 x1pc

9 x2pcs

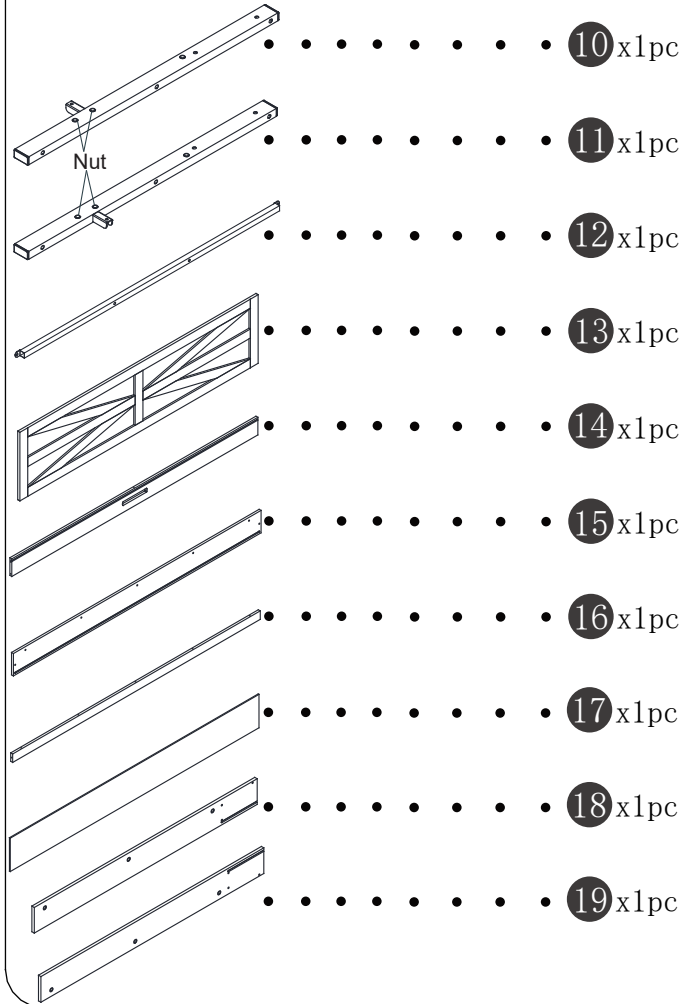

10 x1pc

11 x1pc

12 x1pc

13 x1pc

14 x1pc

15 x1pc

16 x1pc

17 x1pc

18 x1pc

19 x1pc

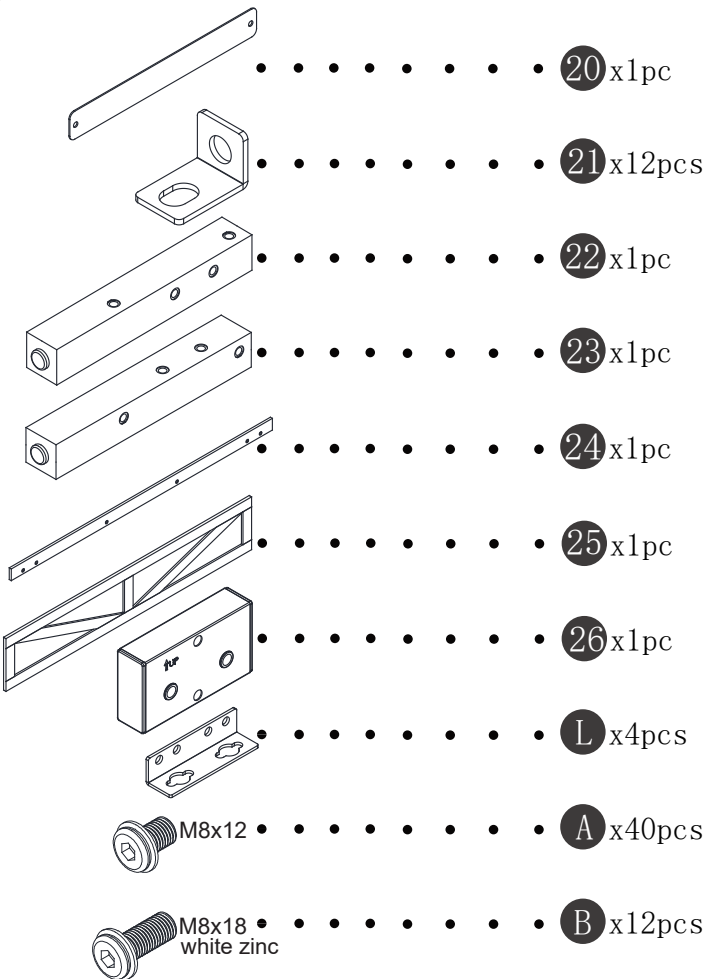

20 x1pc

21 x12pcs

22 x1pc

23 x1pc

24 x1pc

25 x1pc

26 x1pc

L x4pcs

A x40pcs

B x12pcs

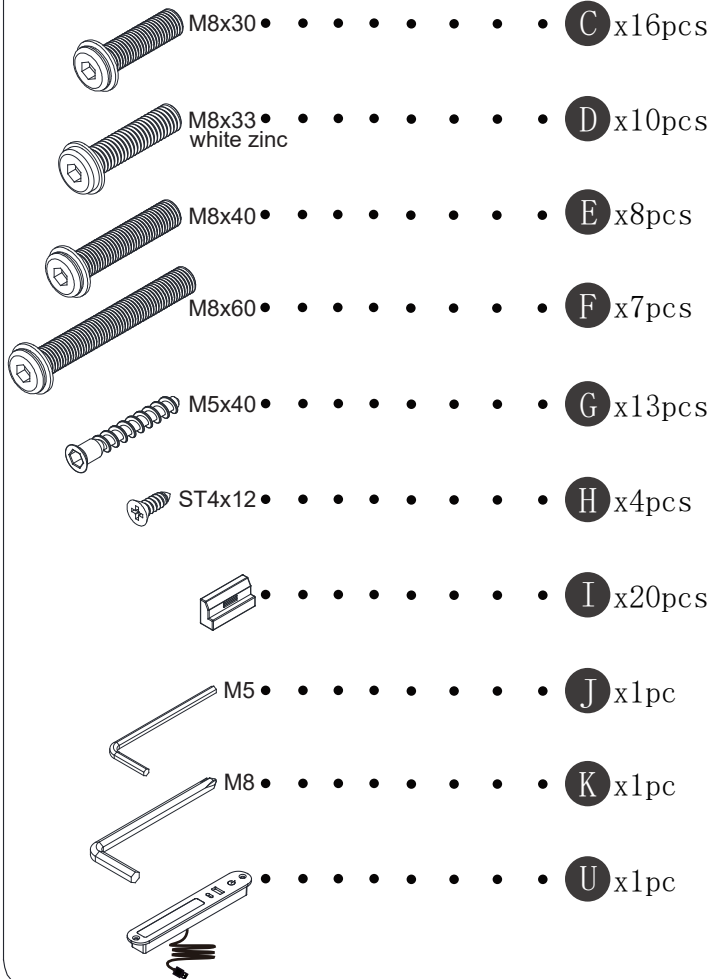

C x16pcs

D x10pcs

E x8pcs

F x7pcs

G x13pcs

H x4pcs

I x20pcs

J x1pc

K x1pc

U x1pc

1

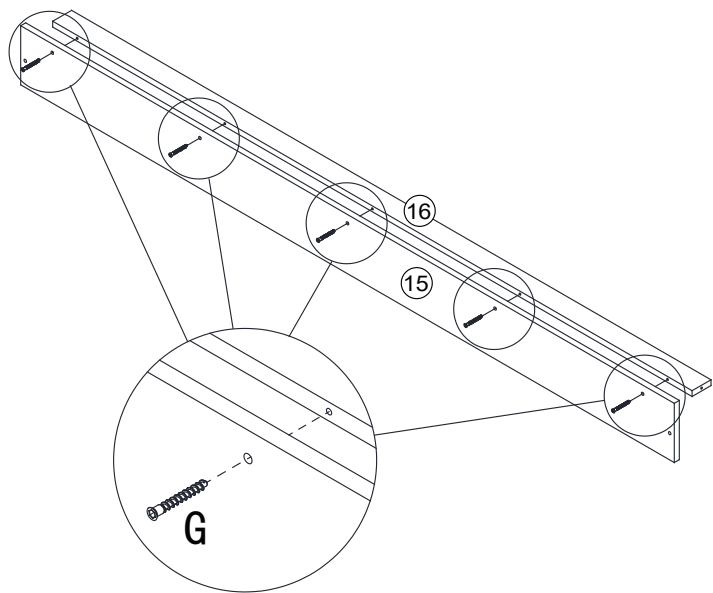

G	 M5x40	5pcs
---	---	------

2

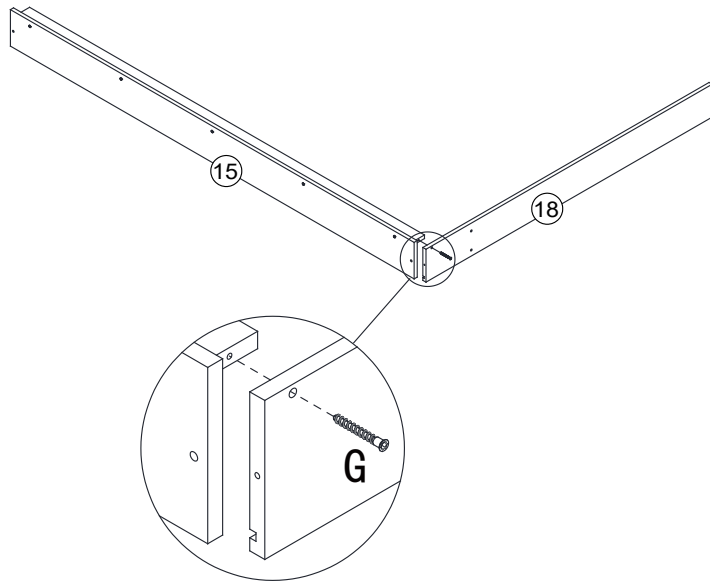

G	 M5x40	1pc
---	--	-----

3

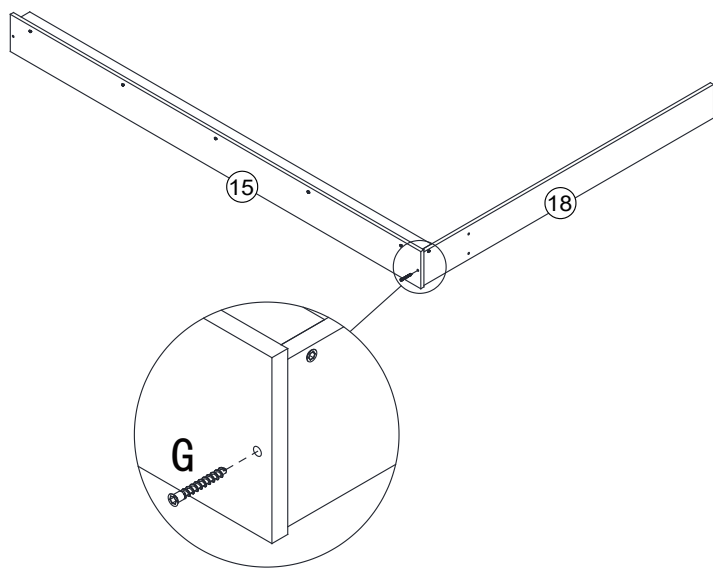

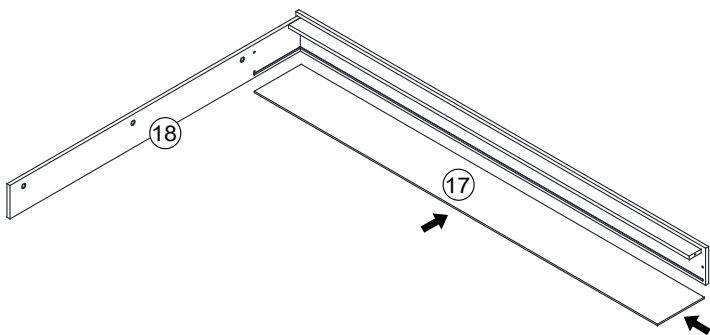

G	 M5x40	1pc
---	---	-----

4



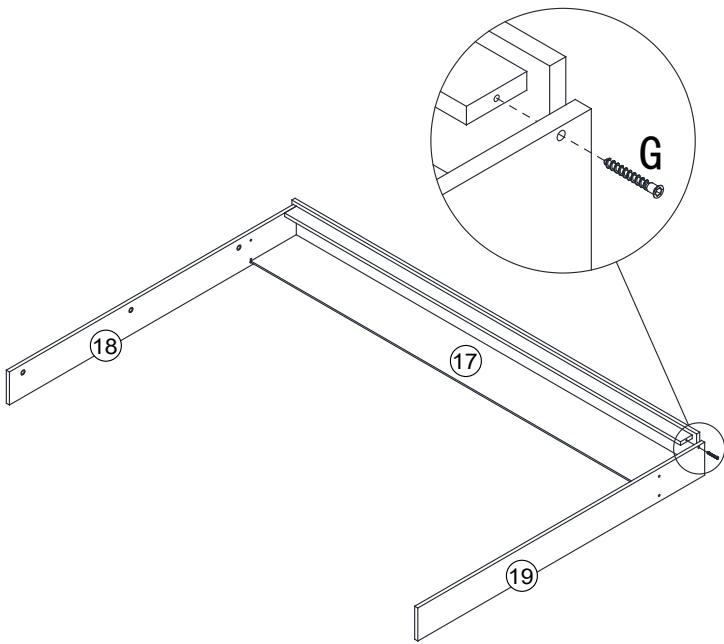

5

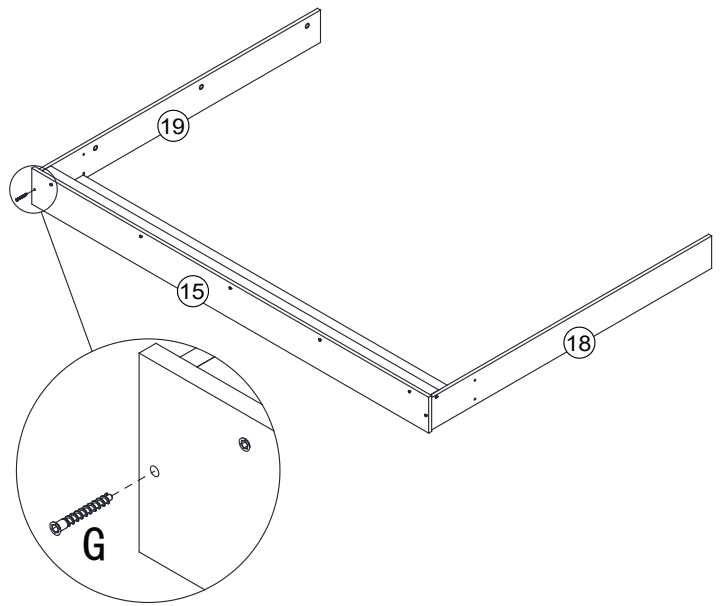

G		1pc
	M5x40	

6



G		1pc
	M5x40	

7

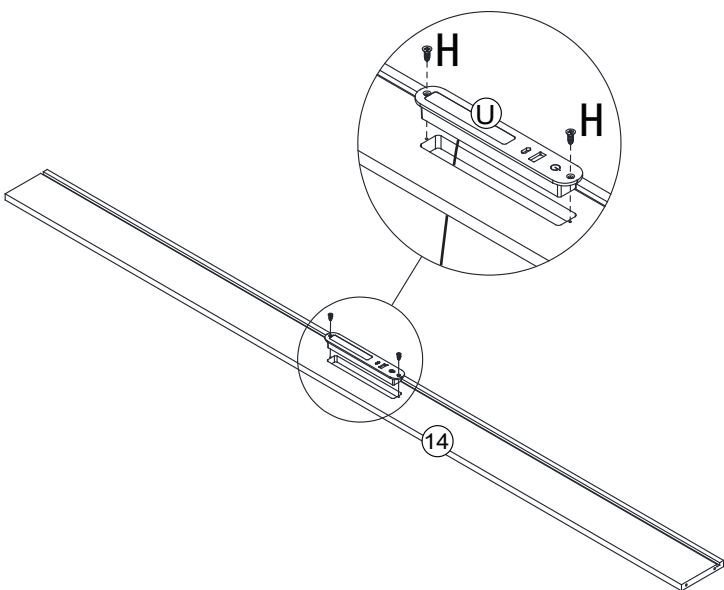

H		2pcs
	ST4x12	

8

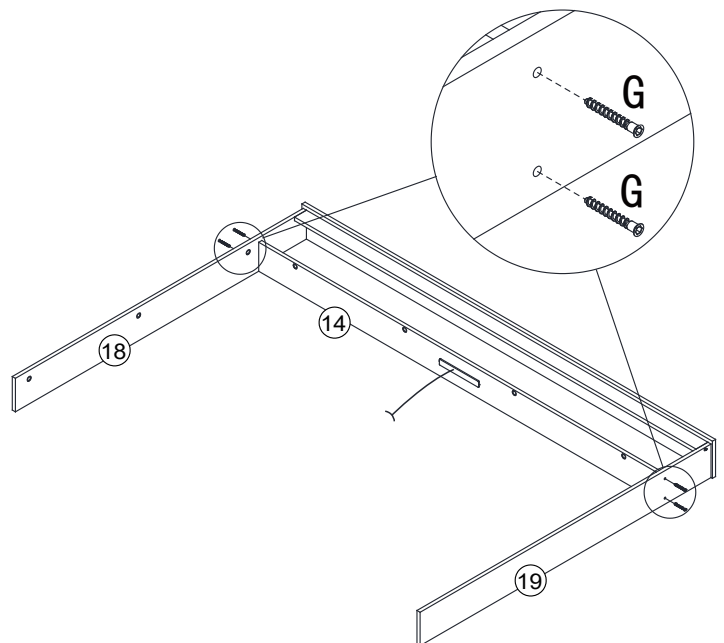

G		4pcs
	M5x40	

9

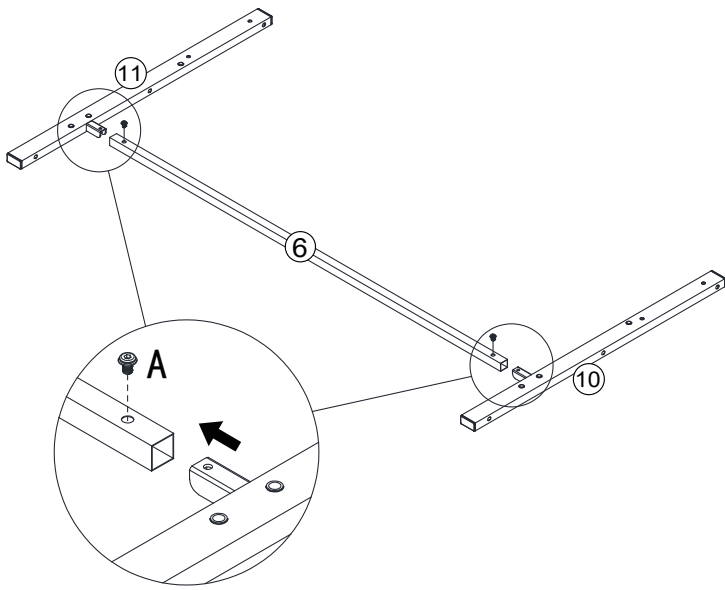

A		2pcs
M8x12		

10

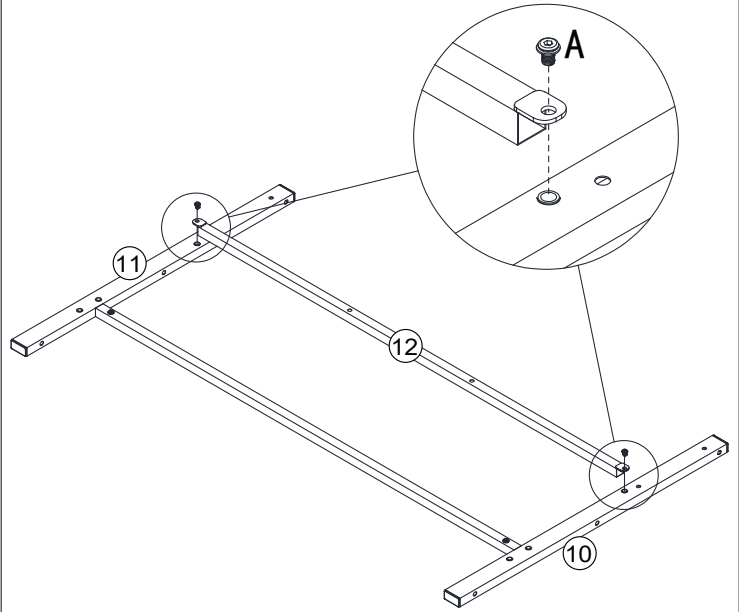

A		2pcs
M8x12		

11

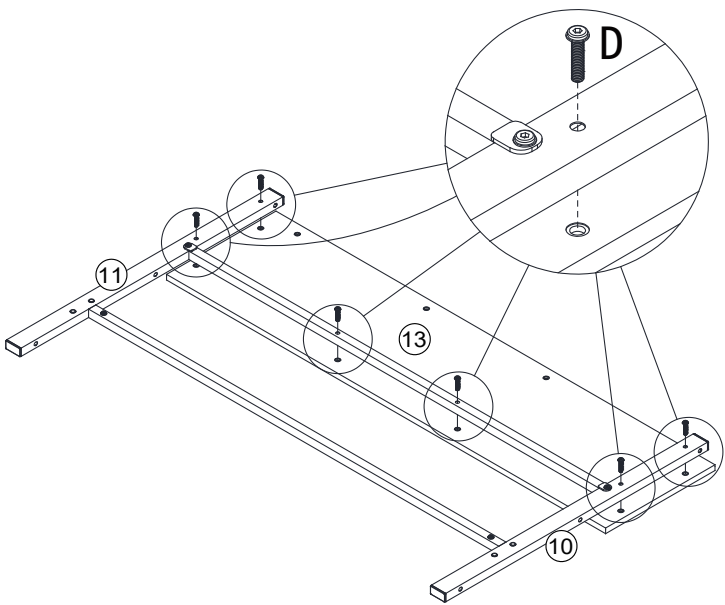

D		6pcs	white zinc
M8x33			

12

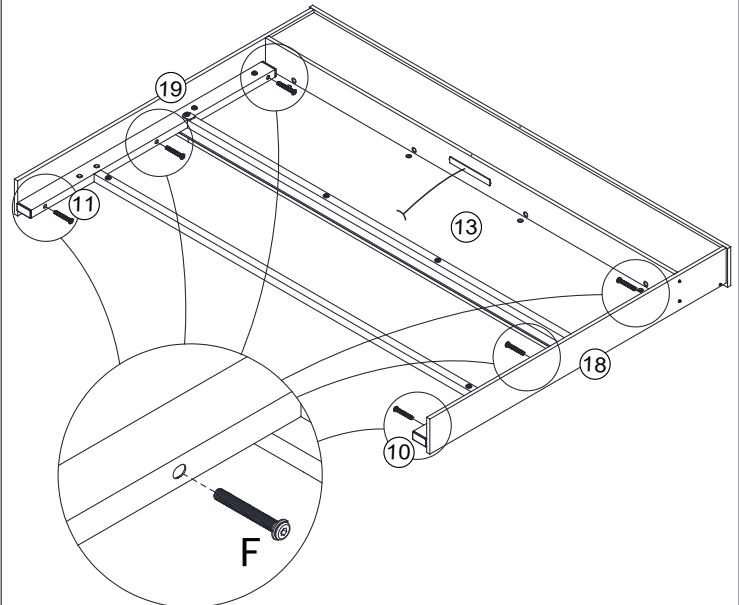

F		6pcs
M8x60		

13

to Assemble first

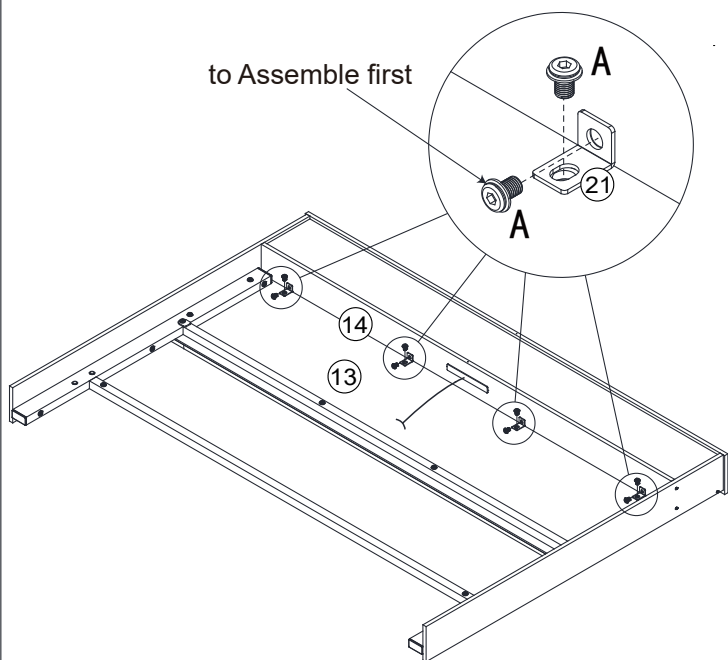

A		8pcs
---	---	------

14

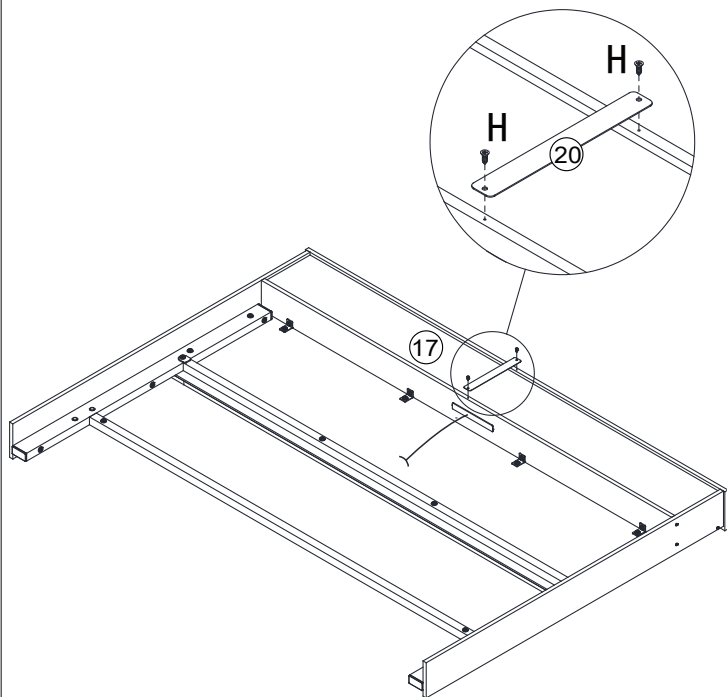

H		2pcs
---	---	------

15

x2

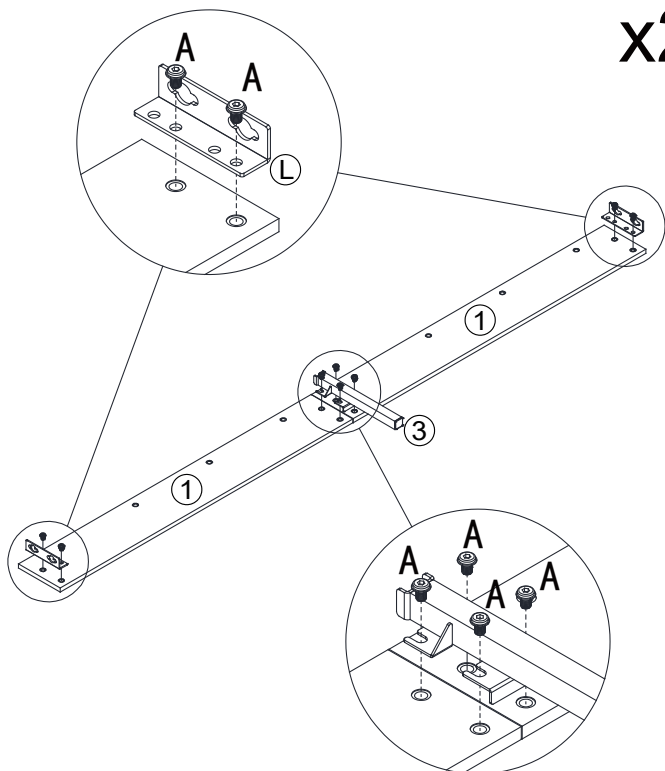



A		16pcs
---	---	-------

16

x2

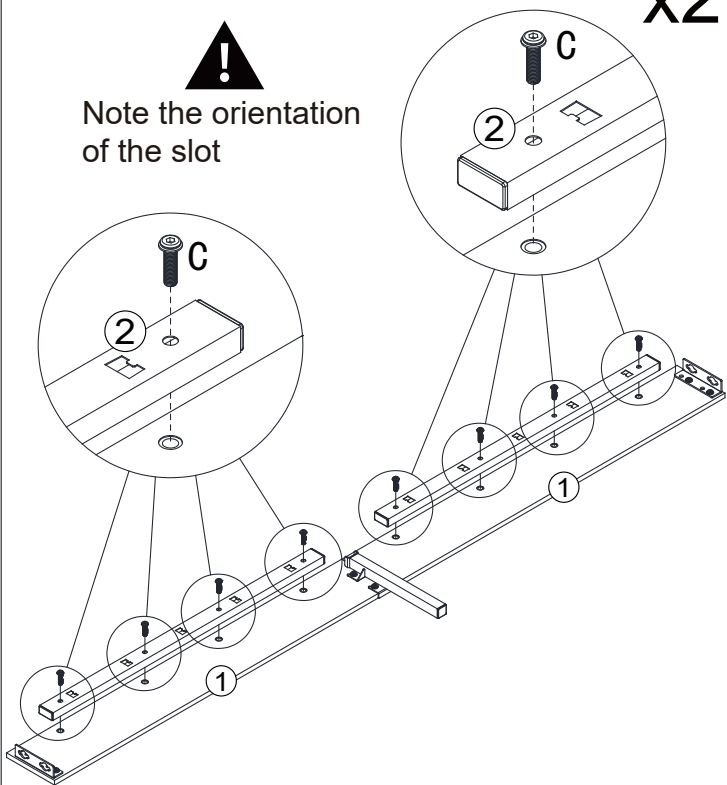
Note the orientation
of the slot



C		16pcs
---	---	-------

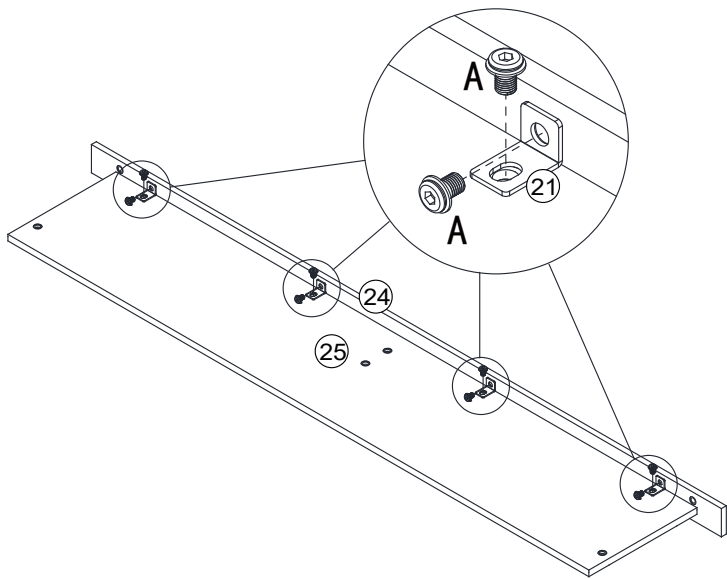

17

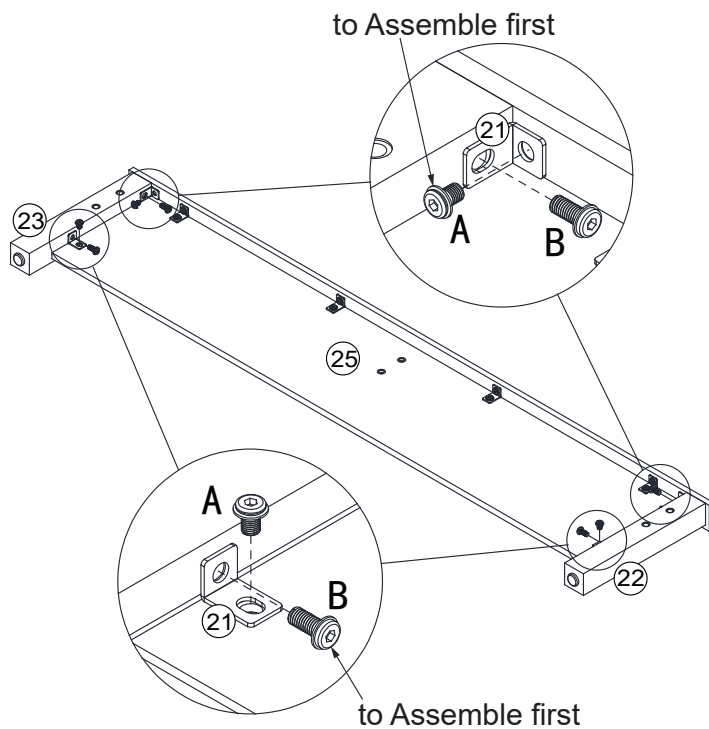

A		8pcs
M8x12		

18



A		4pcs	white zinc
M8x12			
B		4pcs	
M8x18			

19

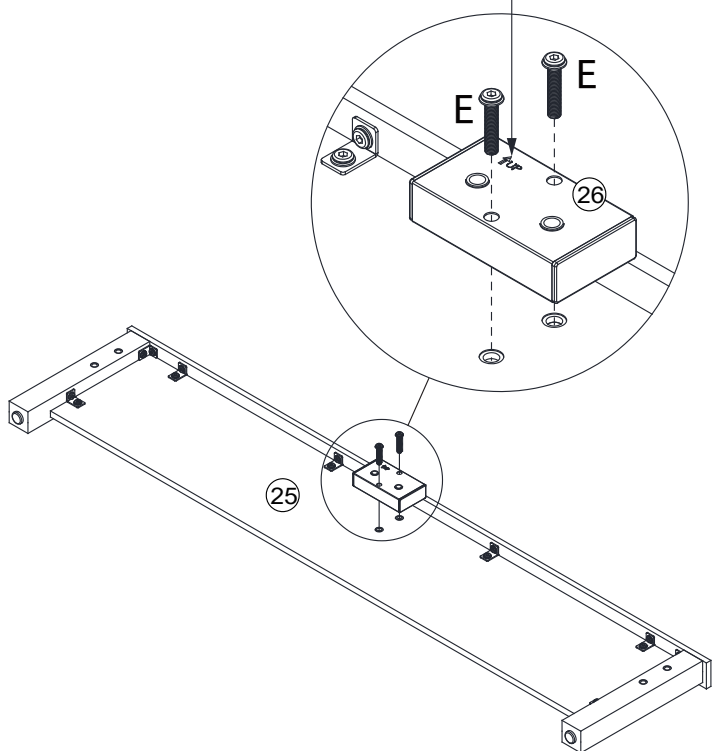

The arrow points upwards.



E		2pcs
M8x40		

20

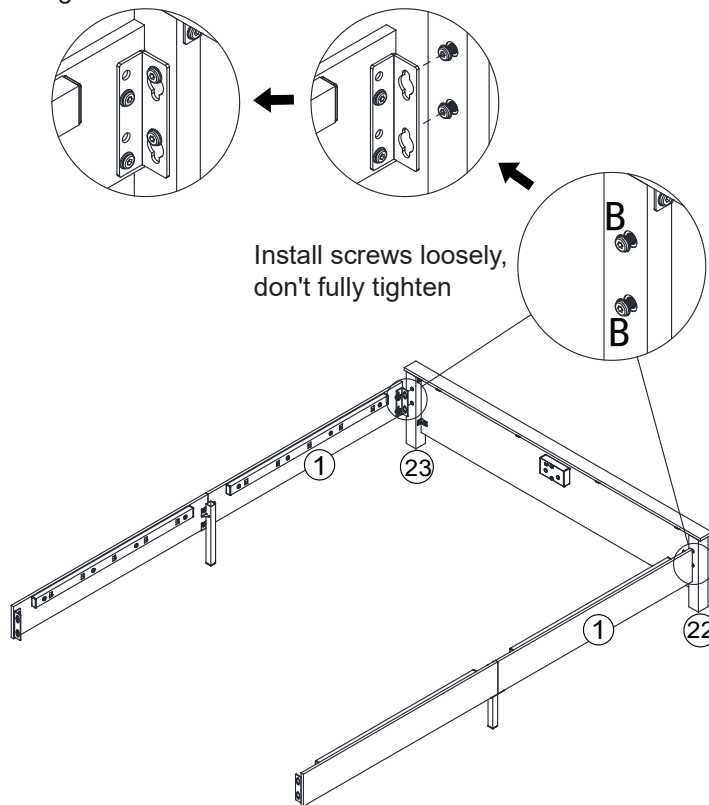
Tighten screws B



B		4pcs	white zinc
M8x18			

21

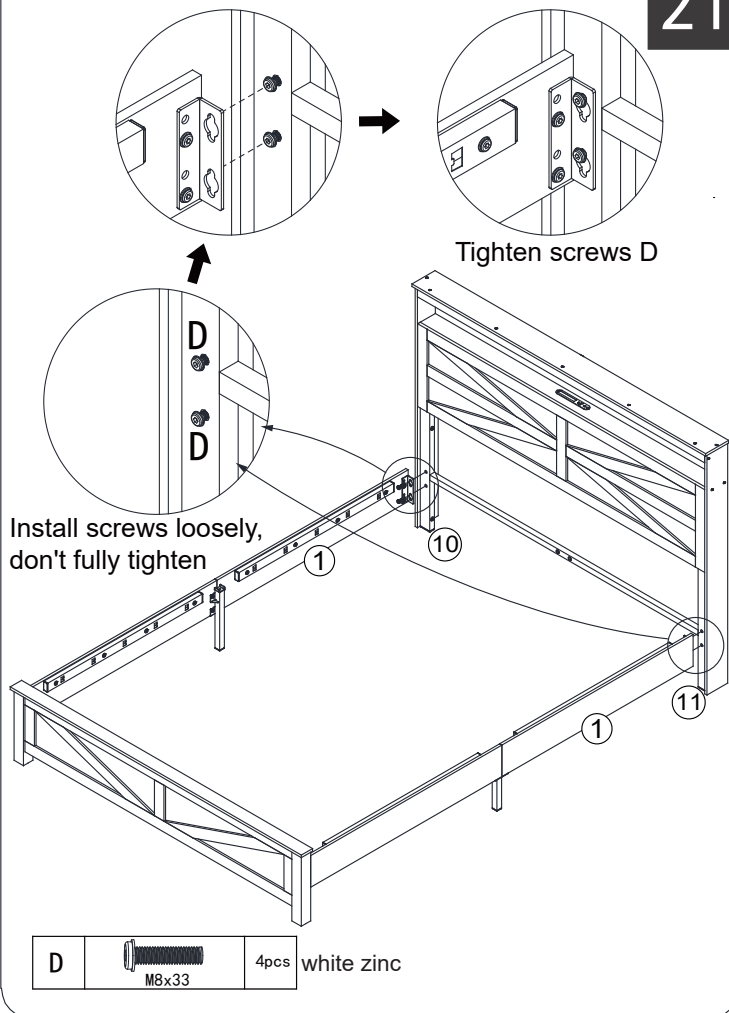

22

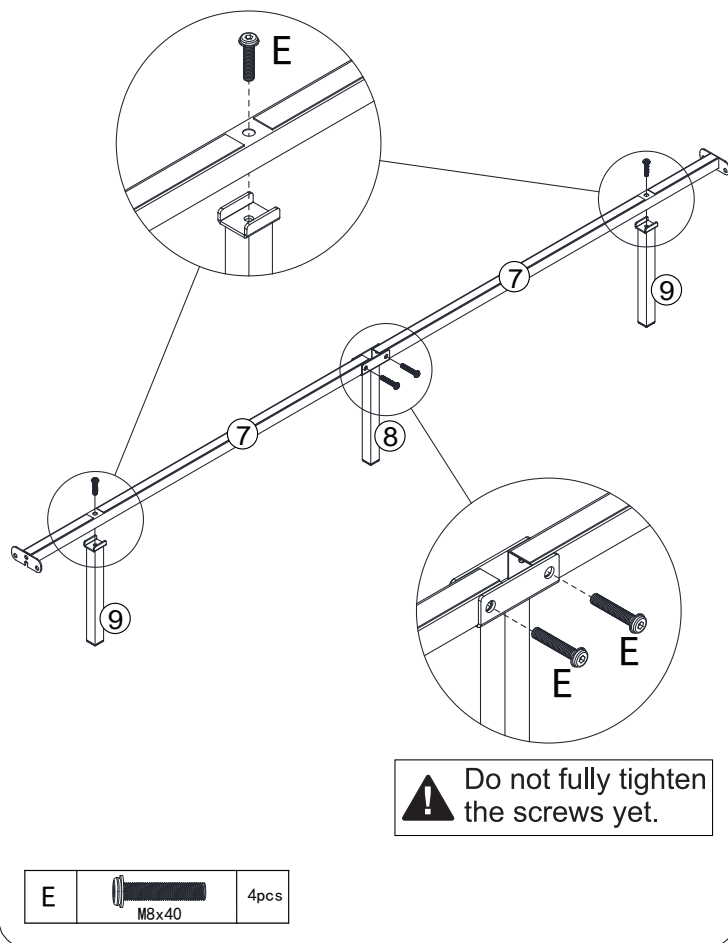

23

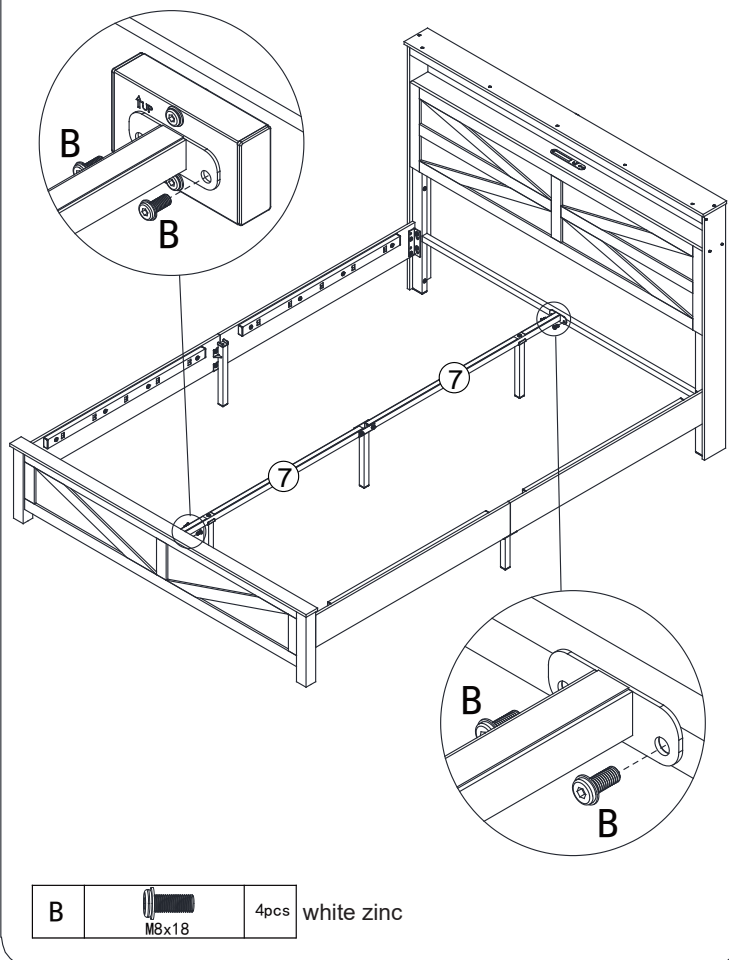

24

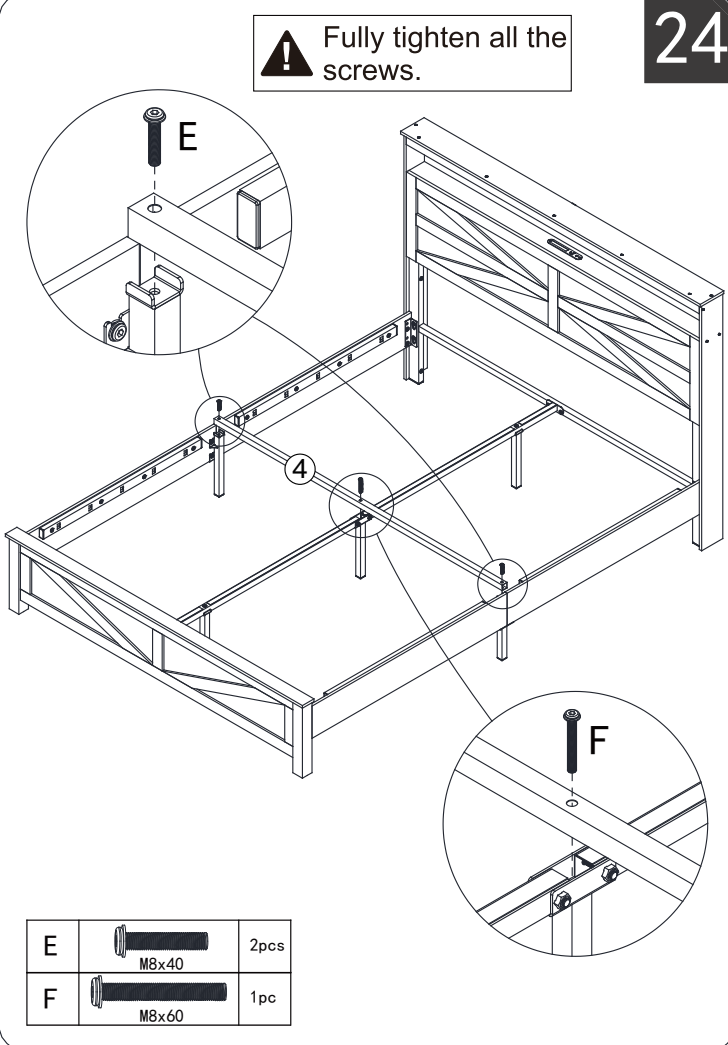

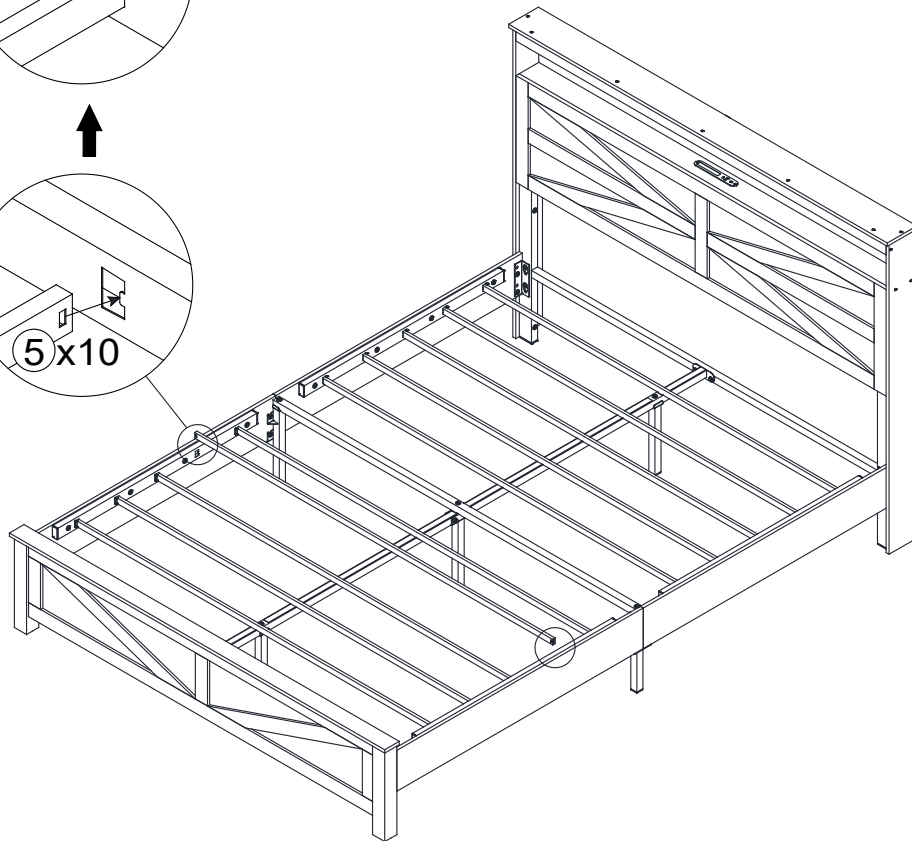
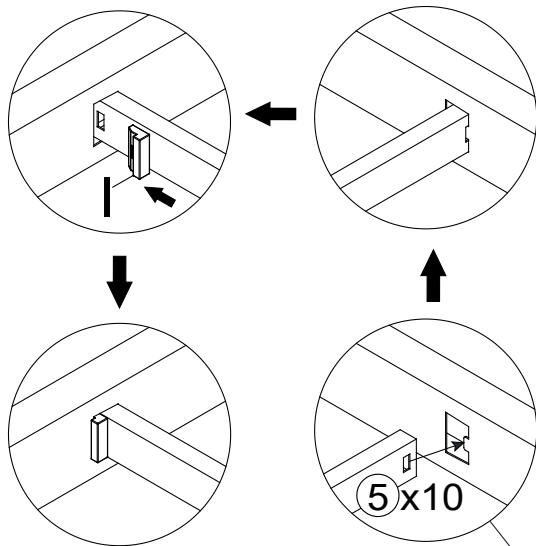

I		20pcs
---	--	-------

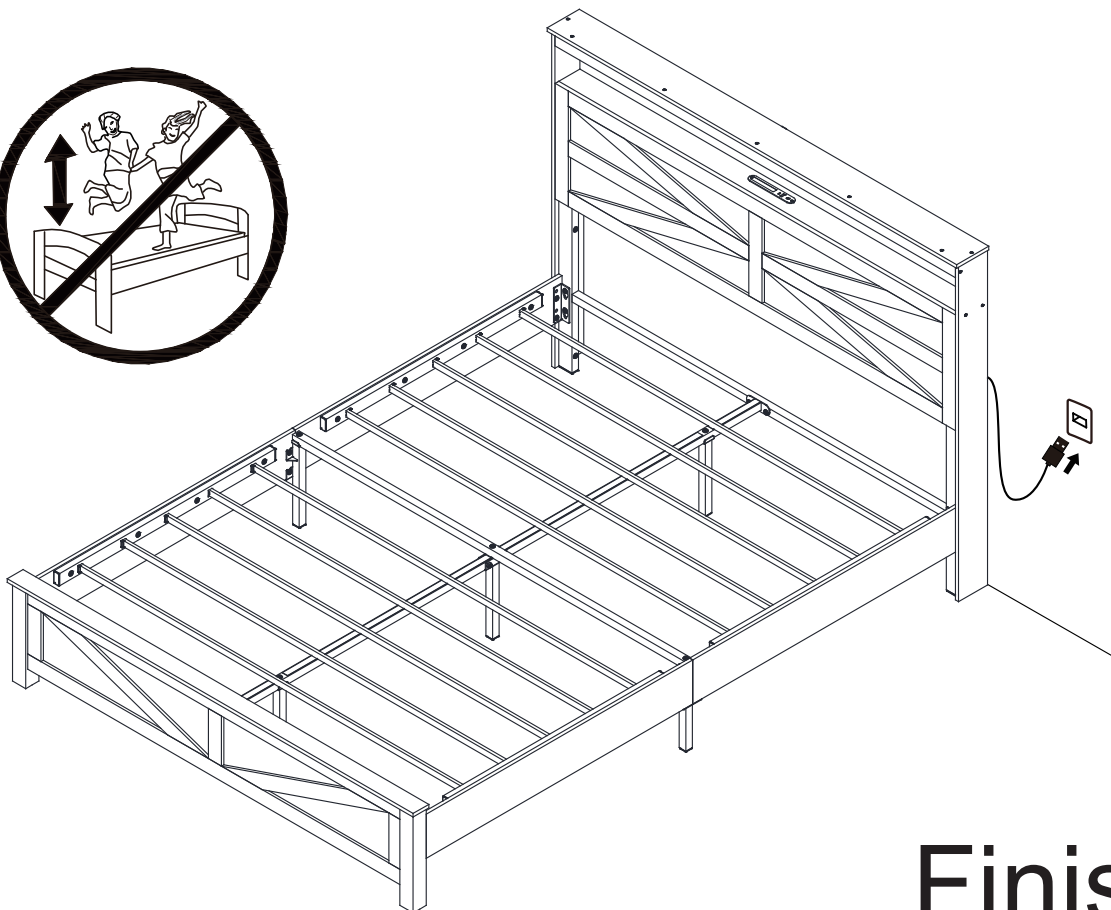

Finish