

24" Upholstered Saddle Seat Bar Stool

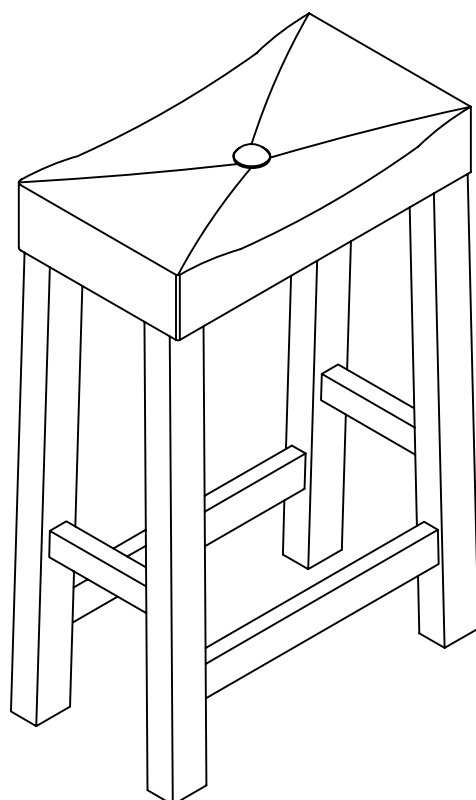

Congratulations! You have purchased a stylish piece of us.

We strive to provide fine furniture products, built with quality materials and hand finished details. Please carefully follow the assembly instructions to ensure your furniture is assembled correctly to provide long lasting enjoyment.

Should you experience any missing or damaged parts, **do not return to the store.**

Care: Use a soft clean cloth that will not scratch the surface when dusting. Use of furniture polish is not necessary. Should you choose to use polishes, test in an inconspicuous area first. Use of solvents of any kind may damage your furniture's finish. To clean, simply use a soft clean cloth moistened with lukewarm water, then buff with a dry soft clean cloth.



24" UPHOLSTERED SADDLE SEAT BAR STOOL

Assembly Instructions

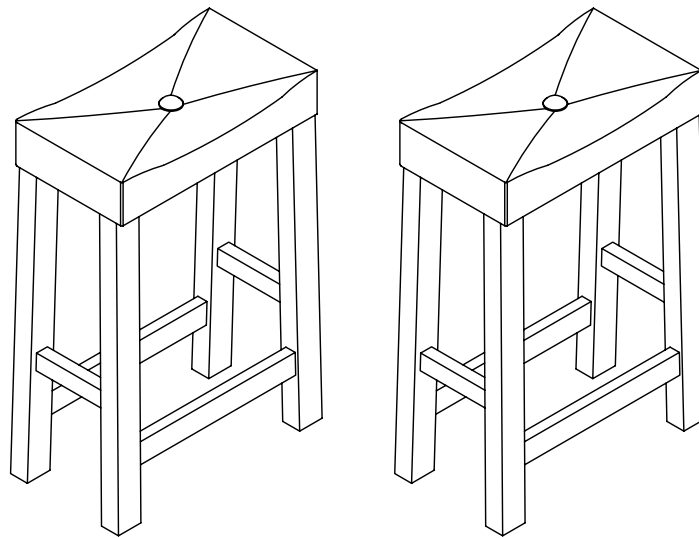

PART LIST:

Part #	Part Name	Drawing	QTY
1	Seat Cushion		2PCS
2	Leg		4PCS
3	Leg		4PCS
4	Short Side Stretcher		4PCS
5	Long Front / Rear Stretcher		4PCS

HARDWARE LIST:

Part #	Part Name	Drawing	QTY
A	Flat Washer ($\phi 18 \times 1.5 \text{mm}$)		8PCS
B	Spring Washer ($\phi 10 \times 2 \text{mm}$)		8PCS
C	Bolt ($\phi 1/4 \times 45 \text{mm}$)		8PCS
D	Wood Screw ($\phi 4 \times 37 \text{mm}$)		16PCS
E	Allen Wrench ($56 \times 21 \times 4 \text{mm}$)		1PC
F	Glue		1PC

Step 1. CHAIR LEGS ASSEMBLY

1A. Add a small amount of glue inside the large holes.

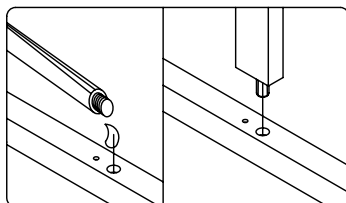

1B. Insert Short Side Stretcher (4) with wood dowel aligned on the upper hole on the side of leg.

1C. Align another leg (2) to the stretcher.

1D. Insert Wood Screws (D) into predrilled holes at both ends of the stretcher.

1E. Tighten Wood Screws (D) with Phillips Head screwdriver (not supplied).

1F. Repeat same step for the other side of legs.

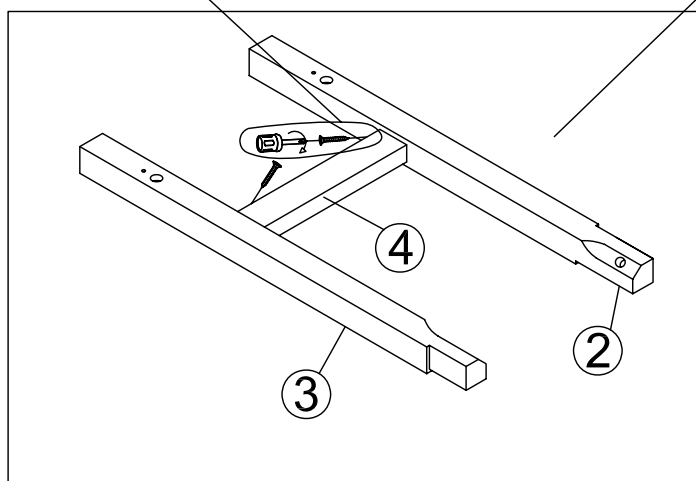
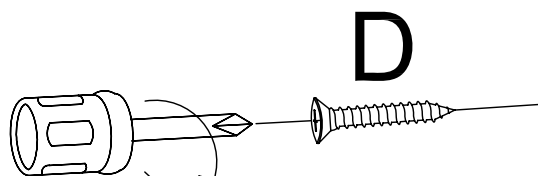
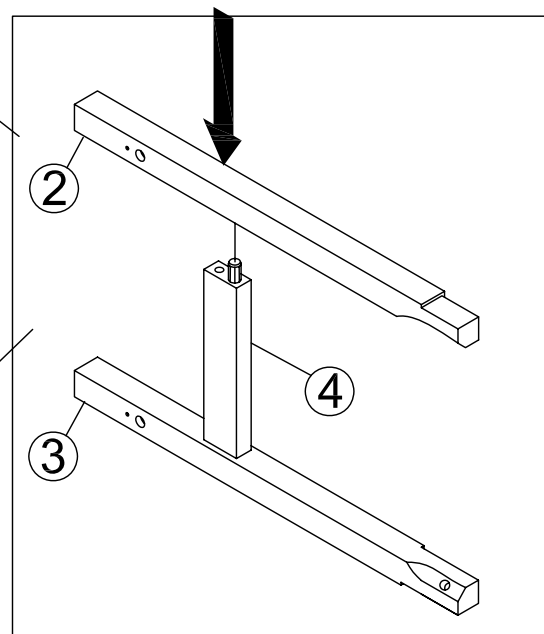
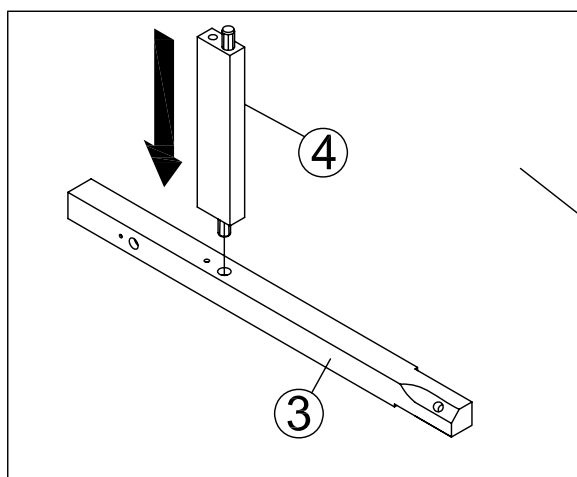

Step 2. FRONT STRETCHER ASSEMBLY

2A. Add a small amount of glue inside the large holes.

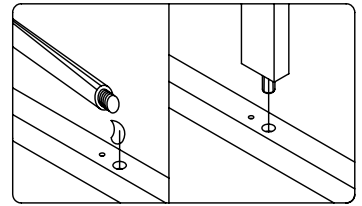

2B. Insert Long Front/Rear Stretchers (5) with wood dowels aligned with the lower holes into one of the completed sides.

2C. Attach remaining side to the other end of the Long Front/Rear Stretchers (5) with wood dowels aligned with the lower holes.

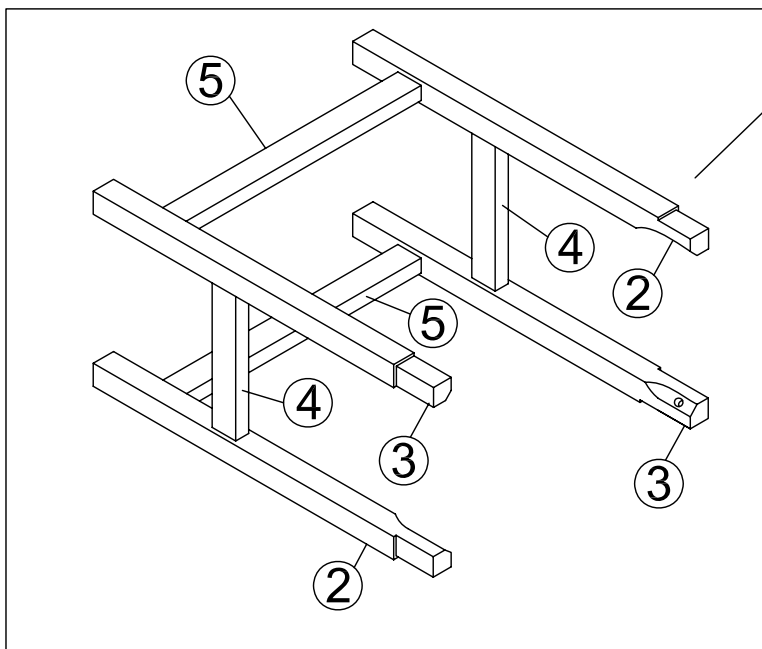
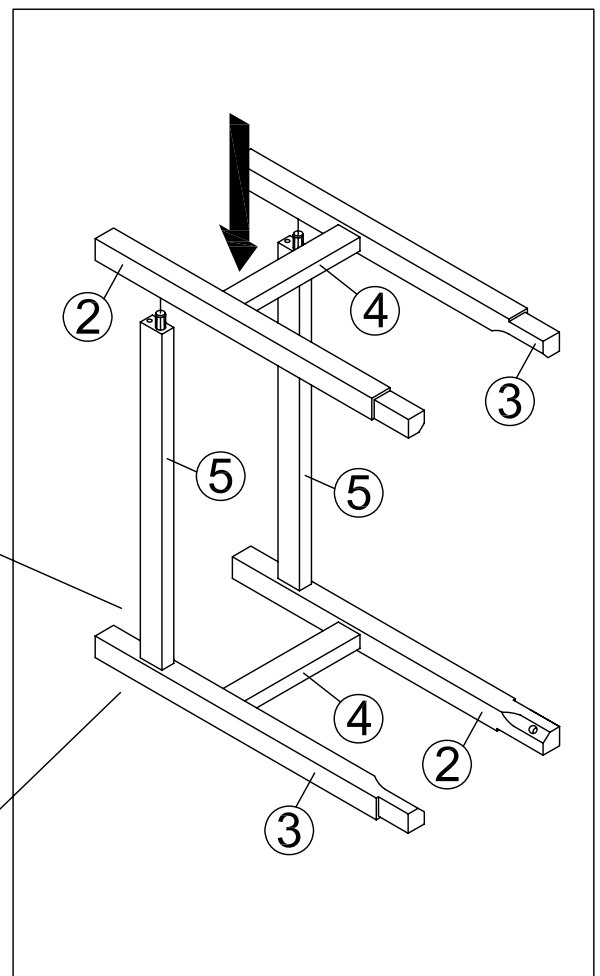
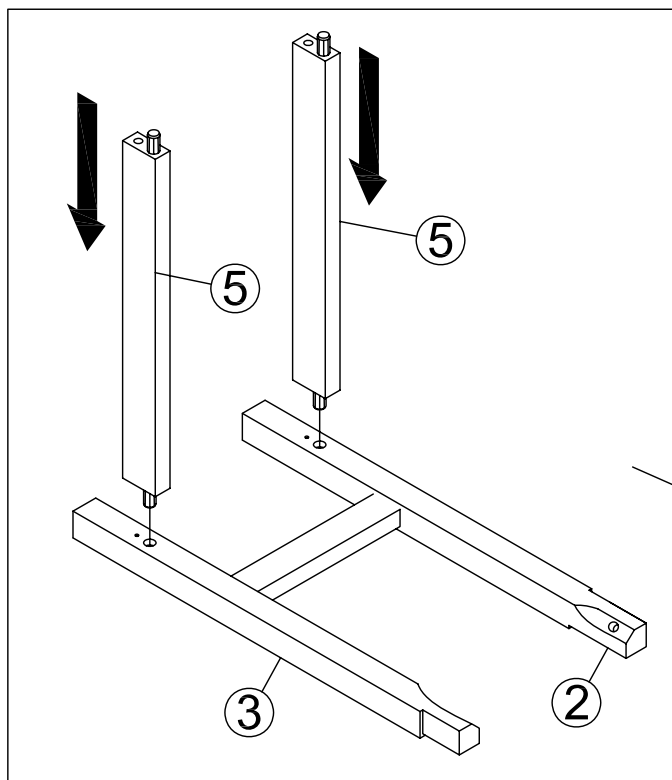

Step 3. CUSHION SEAT ASSEMBLY

- 3A. Place seat cushion (1) upside down on a clean cloth.
- 3B. Slowly insert legs into the bottom frame of seat cushion.
- 3C. Insert Bolt (C) with Spring Washer (B) and Flat Washer (A) through seat frame into legs.
- 3D. Turn bolts clockwise with Allen Wrench (E) until tight.
- 3E. Insert Wood Screws (D) into both ends of Long Front/Rear Stretchers and tighten with Phillips Head screwdriver (not supplied).

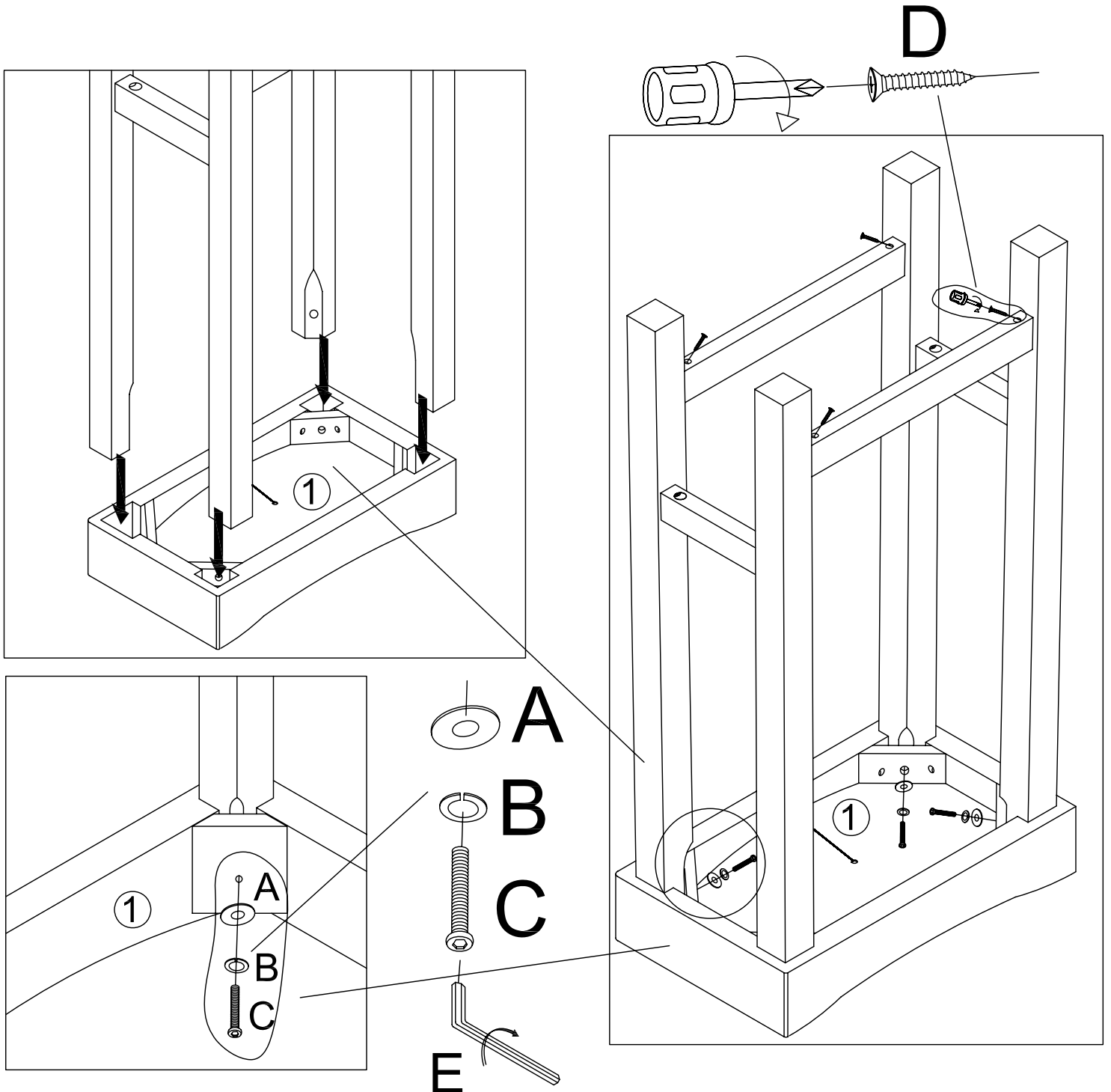

Repeat steps 1-3 to assemble remaining stool.

Limited Manufacturers Warranty

Our Products are warranted against defects in material and workmanship for a period of 90 days beginning from the date of sale. Should any parts be missing or defective, we will replace or repair the parts for a period of 90 days from the date of purchase.

Should you experience any missing or damaged parts, do not return to the store. Please contact us directly.

This warranty gives the purchaser specified legal rights in addition to any rights which may vary from state to state.

In accordance with the "Moss-Magnuson Warranty Act" of July 10, 1975, this is termed a "limited warranty" which in no way compromises our high standards of Quality and Workmanship.