

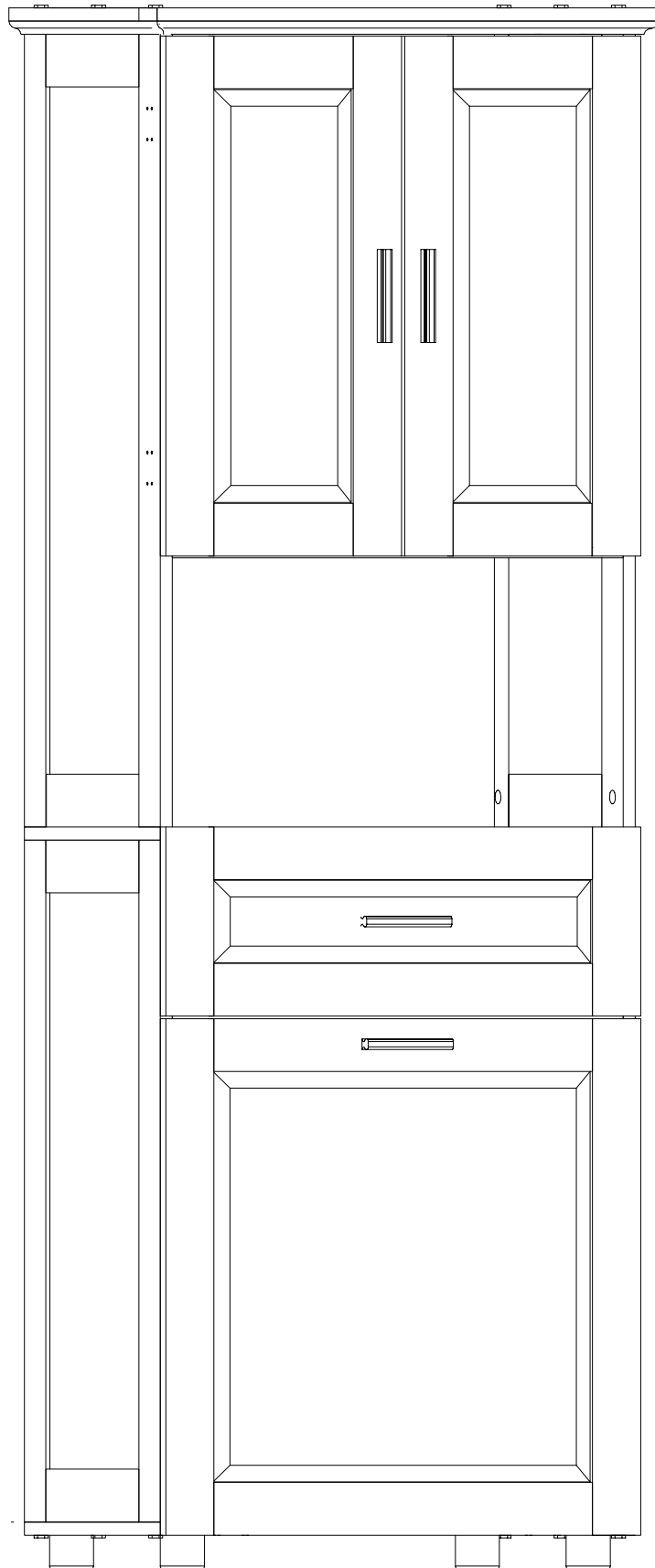

# ASSEMBLY INSTRUCTION

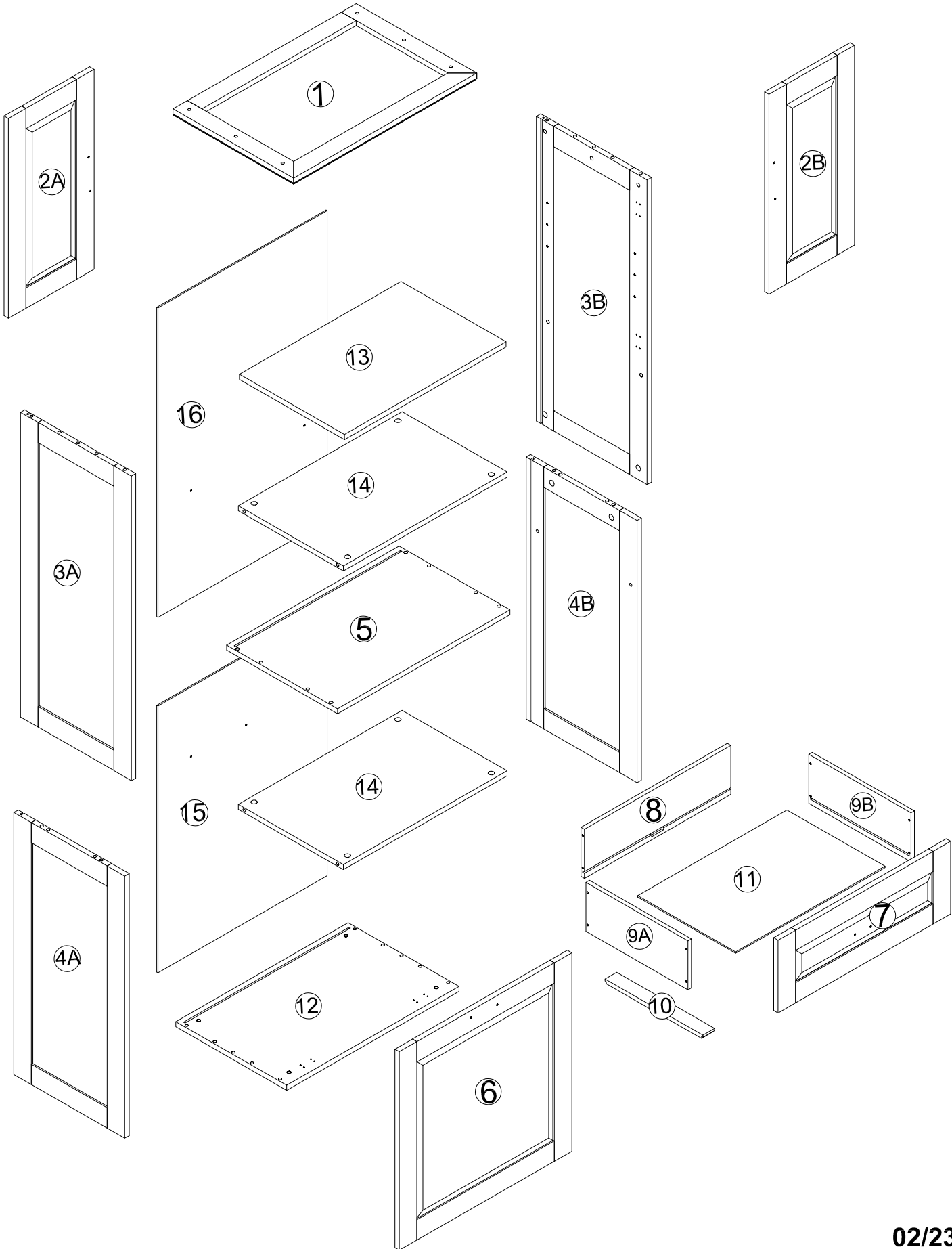





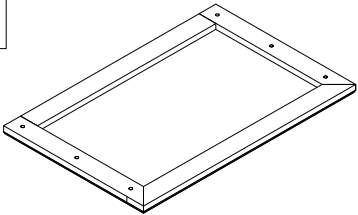
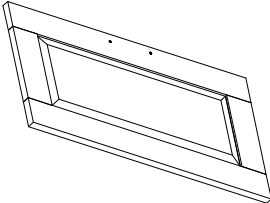
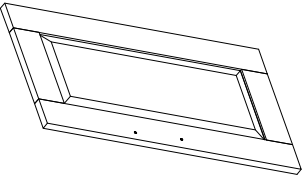
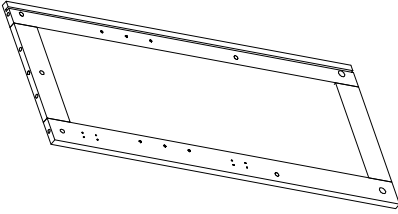
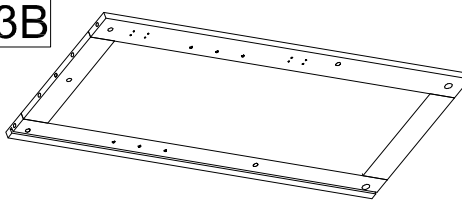
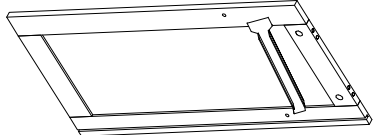
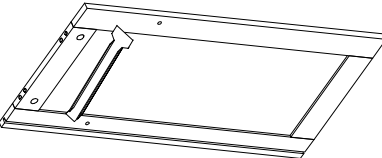

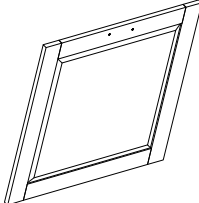
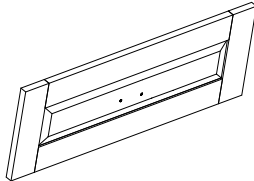
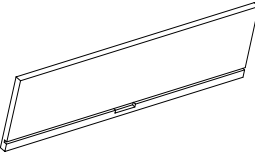
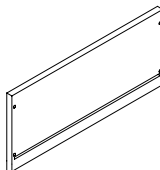
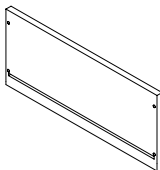
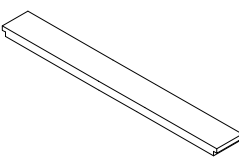
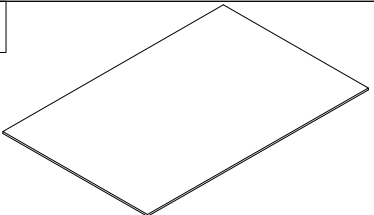
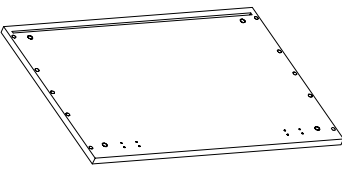
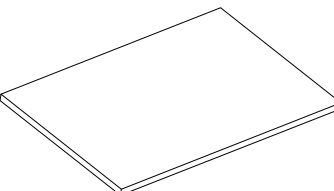
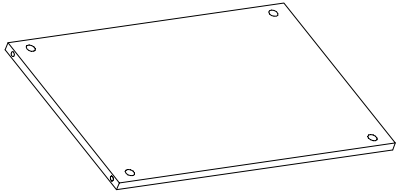
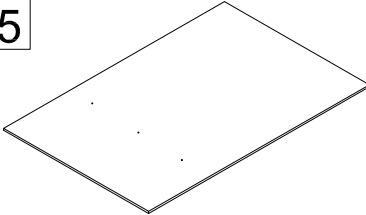
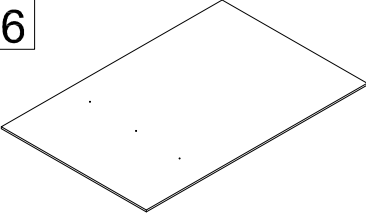
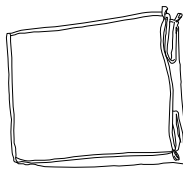

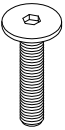

# ASSEMBLY INSTRUCTION

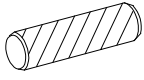
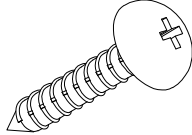
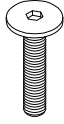
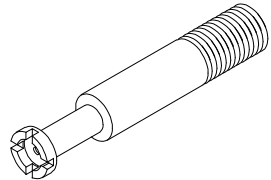
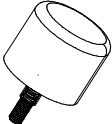
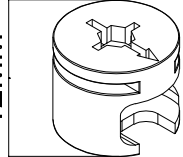
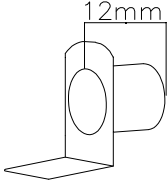
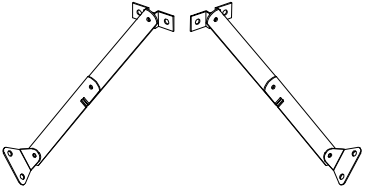

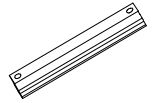
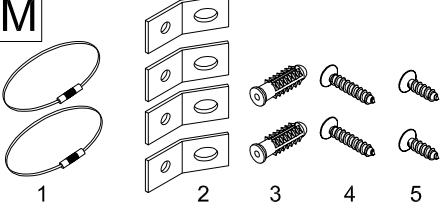
# Part List

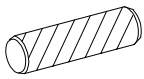
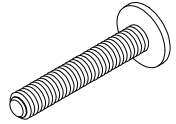
<p><b>1</b></p>  <p>The top of the cabinet-1pcs</p>	<p><b>2A</b></p>  <p>CABINET WINGS-1pcs</p>	<p><b>2B</b></p>  <p>CABINET WINGS-1pcs</p>
<p><b>3A</b></p>  <p>SIDE EDGE OF CABINET-1pc</p>	<p><b>3B</b></p>  <p>SIDE EDGE OF CABINET-1pc</p>	<p><b>4A</b></p>  <p>SIDE EDGE OF CABINET-1pc</p>
<p><b>4B</b></p>  <p>SIDE EDGE OF CABINET-1pc</p>	<p><b>5</b></p>  <p>CABINET COMPARTMENT PANELS-1pcs</p>	<p><b>6</b></p>  <p>CABINET WINGS-1pcs</p>
<p><b>7</b></p>  <p>DRAWER-FRONT Panels-1pc</p>	<p><b>8</b></p>  <p>DRAWER-Back Panels-1pcs</p>	<p><b>9A</b></p>  <p>DRAWER-SIDE Panels-1pcs</p>
<p><b>9B</b></p>  <p>DRAWER-SIDE Panels-1pcs</p>	<p><b>10</b></p>  <p>Drawers-Support Bottom-1pcs</p>	<p><b>11</b></p>  <p>Drawer-Bottom Panels-1pcs</p>
<p><b>12</b></p>  <p>CABINET BOTTOM-1pcs</p>	<p><b>13</b></p>  <p>MOVING SHELVES-1pcs</p>	<p><b>14</b></p>  <p>FIXED SHELF-2pcs</p>
<p><b>15</b></p>  <p>Cabinet Back-1pcs</p>	<p><b>16</b></p>  <p>Cabinet Back-1pcs</p>	<p><b>T</b></p>  <p>Cloth Bag-1pc</p>

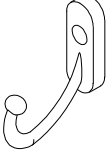
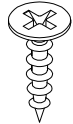
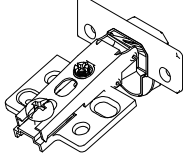

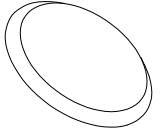

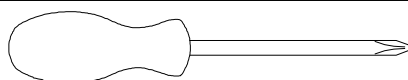
# Hardware List

<p><b>A</b></p>  <p>Ø1/4" x 70mm Hex-Head bolts 6pcs</p>	<p><b>B</b></p>  <p>Ø1/4" x 10 mm Horizontal-Hole bolts 12pcs</p>	<p><b>C</b></p>  <p>Ø8 x 30 mm Wood dowel 8pcs</p>
<p><b>D</b></p>  <p>M4 x 30 mm Wood Screws 18pcs</p>	<p><b>E</b></p>  <p>Ø1/4" x 50mm Hex-Head bolts 6pcs</p>	<p><b>F</b></p>  <p>Link 1 - 16 pcs</p>
<p><b>G</b></p>  <p>Plastic Feet(Ø50x40) 4pcs</p>	<p><b>H</b></p>  <p>12MM Link 2 - 16 pcs</p>	<p><b>I</b></p>  <p>12mm Support Pin 4pcs</p>
<p><b>J</b></p>  <p>Crankshaft 1 set (1L-1R)</p>	<p><b>K</b></p>  <p>Allen Key 1pc</p>	<p><b>L</b></p>  <p>Handle Steel 4pcs</p>
<p><b>M</b></p>  <p>1 2 3 4 5 Wall brackets 2set</p>	<p><b>N</b></p>  <p>1 2 Clamp pin 2pcs</p>	<p><b>O</b></p>  <p>Ø8 x 60 mm Wood dowel 4pcs</p>
<p><b>P</b></p>  <p>M4 x 18mm Hex-Head bolts 6pcs</p>	<p><b>R</b></p>  <p>M3.5 x 15mm Wood Screws 4pcs</p>	<p><b>Q</b></p>  <p>Hanger 4pcs</p>
<p><b>W</b></p>  <p>M4 x 15 mm Wood Screws 58pcs</p>	<p><b>X</b></p>  <p>Hinge - 6Pcs</p>	<p><b>Z</b></p>  <p>M4 x 30mm Wood Screws 8pcs</p> <p><b>Y</b></p>  <p>Plastic button 16pcs</p>



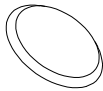
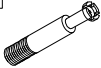

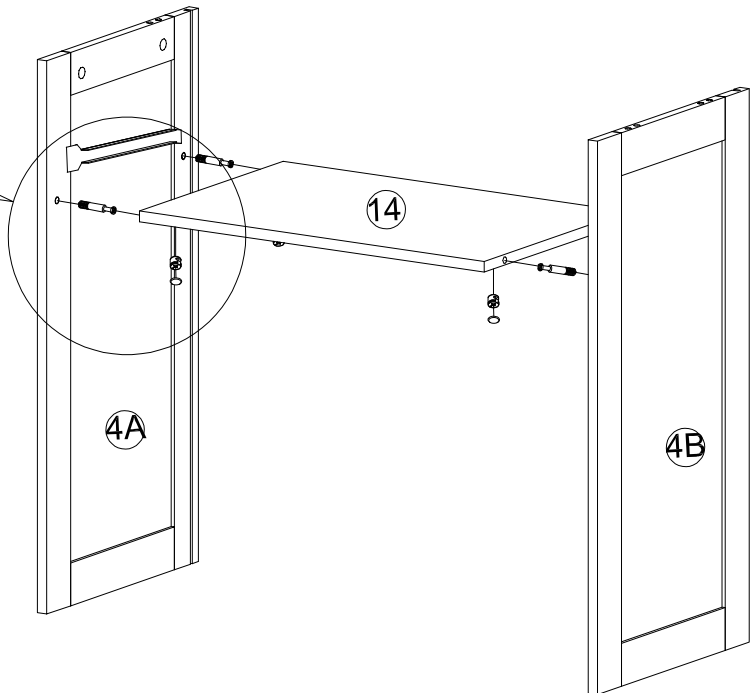
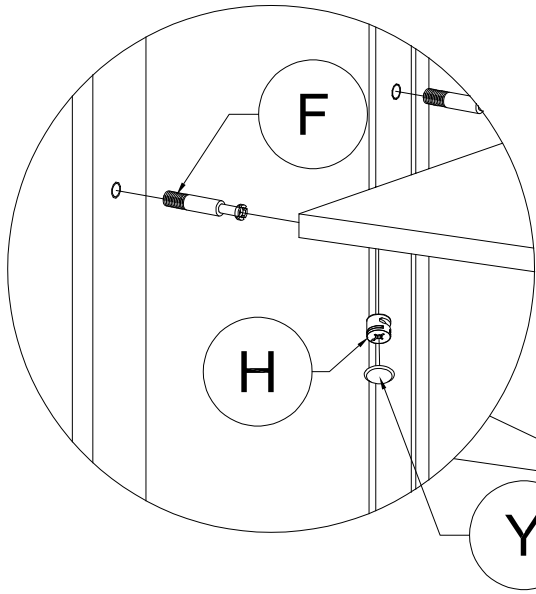
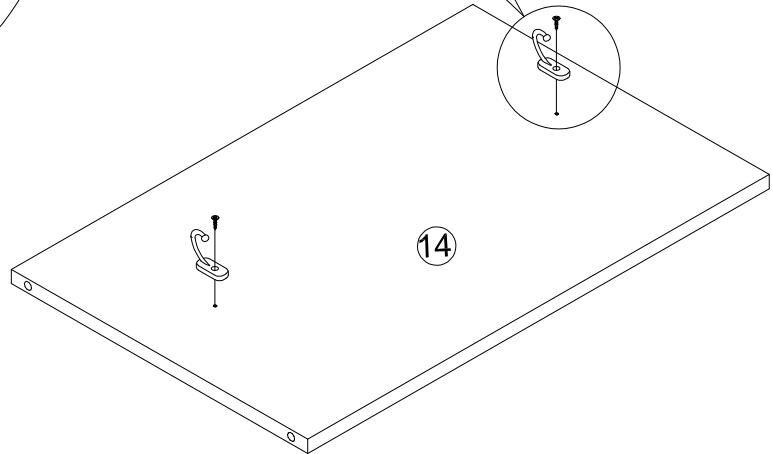
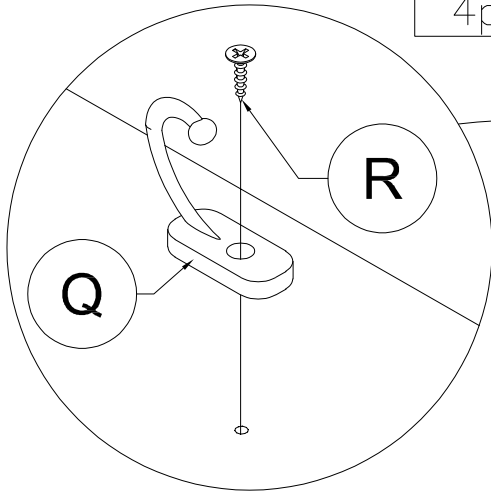

**Assembly Tools Required (Not Included)**

# STEP 1: Following below illustration:

Y	F	H	Q	R
				
4pcs	4pcs	4pcs	2pcs	2pcs

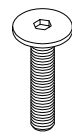

## STEP 2: Following below illustration:



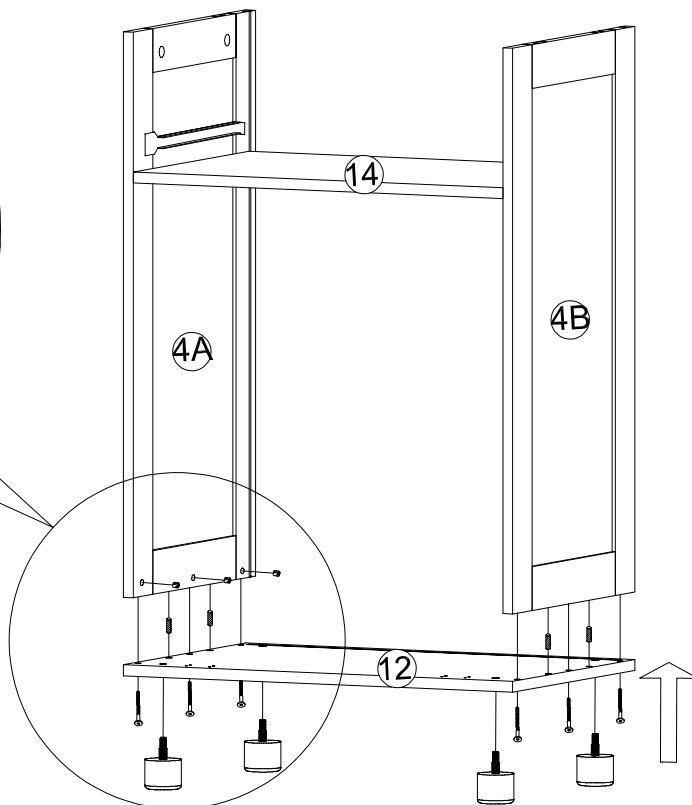
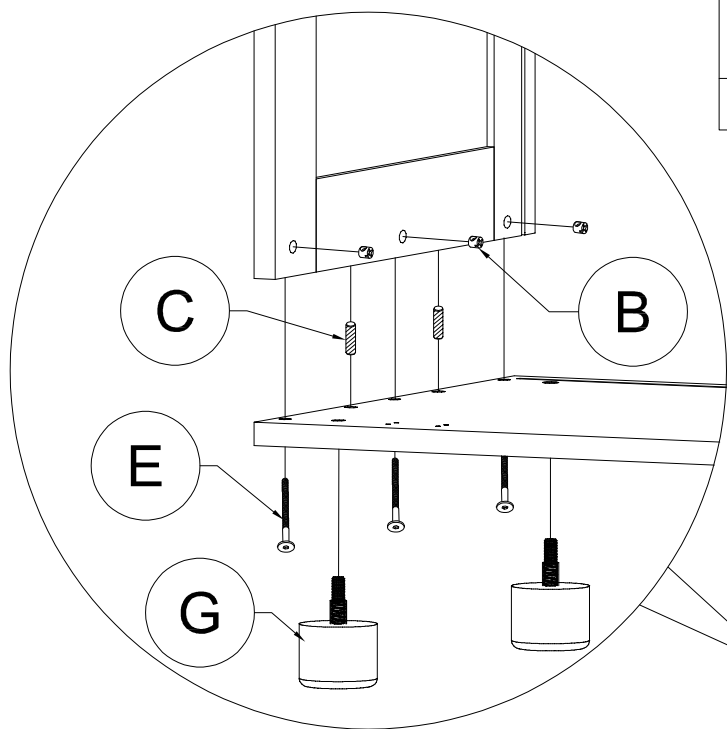

<b>G</b> 	<b>C</b> 	<b>E</b> 	<b>B</b> 
4pcs	4pcs	6pcs	6pcs

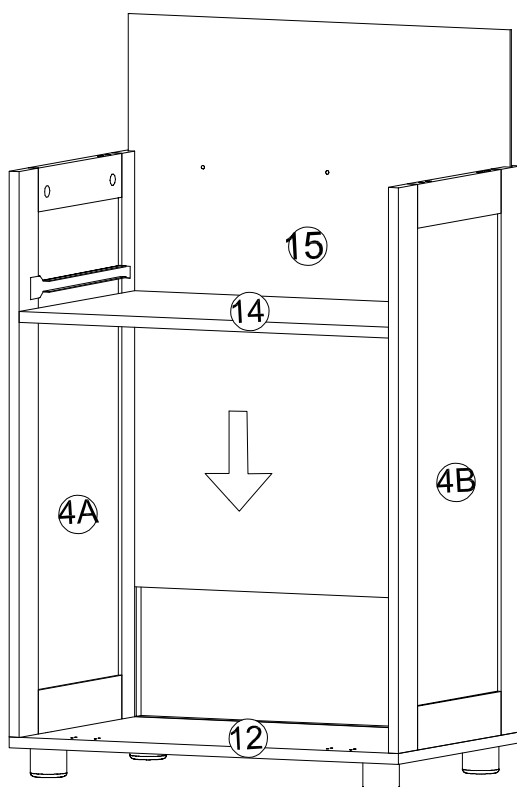

## STEP 3: Following below illustration:

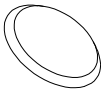

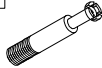

# STEP 4: Following below illustration:

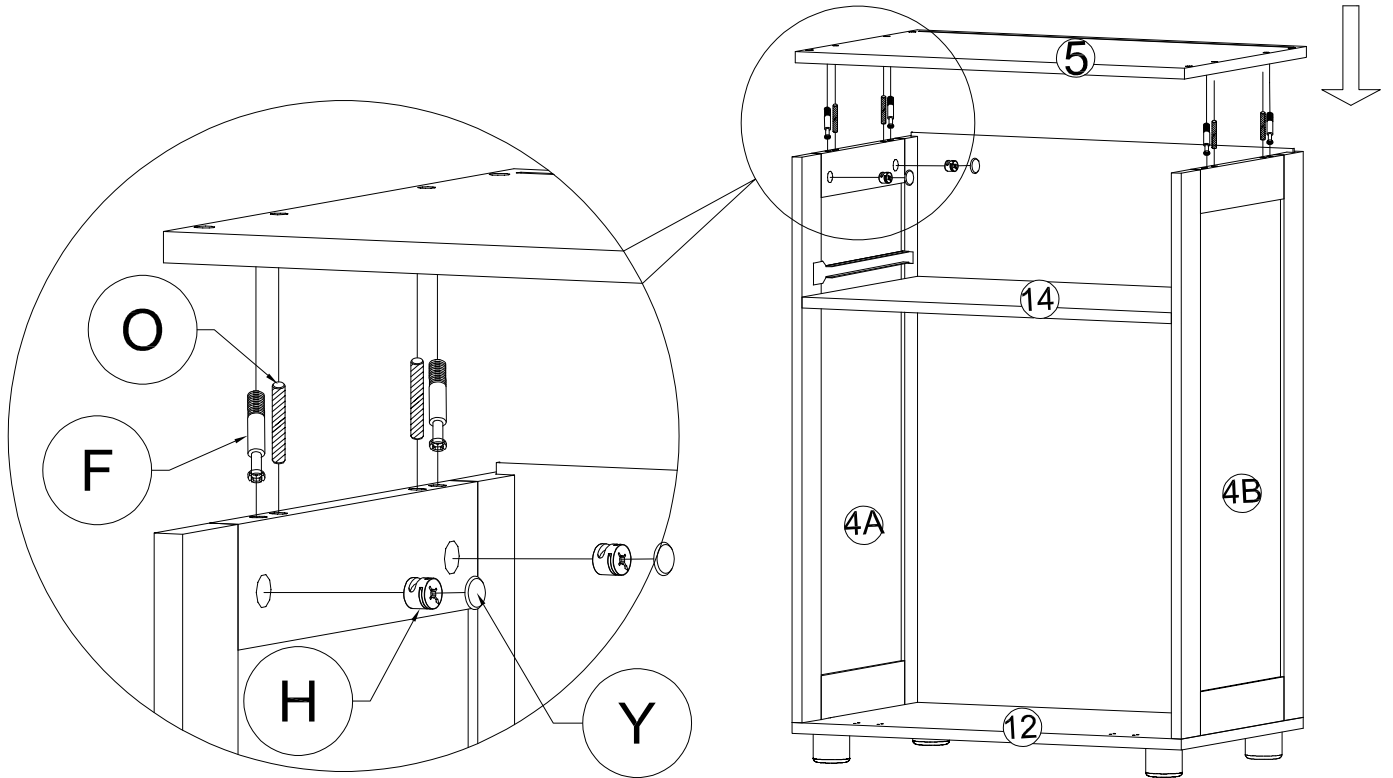
Y	O	F	H
			
4pcs	4pcs	4pcs	4pcs

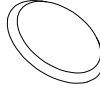
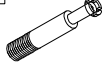

# STEP 5: Following below illustration:

Y	F	H
		
4pcs	4pcs	4pcs

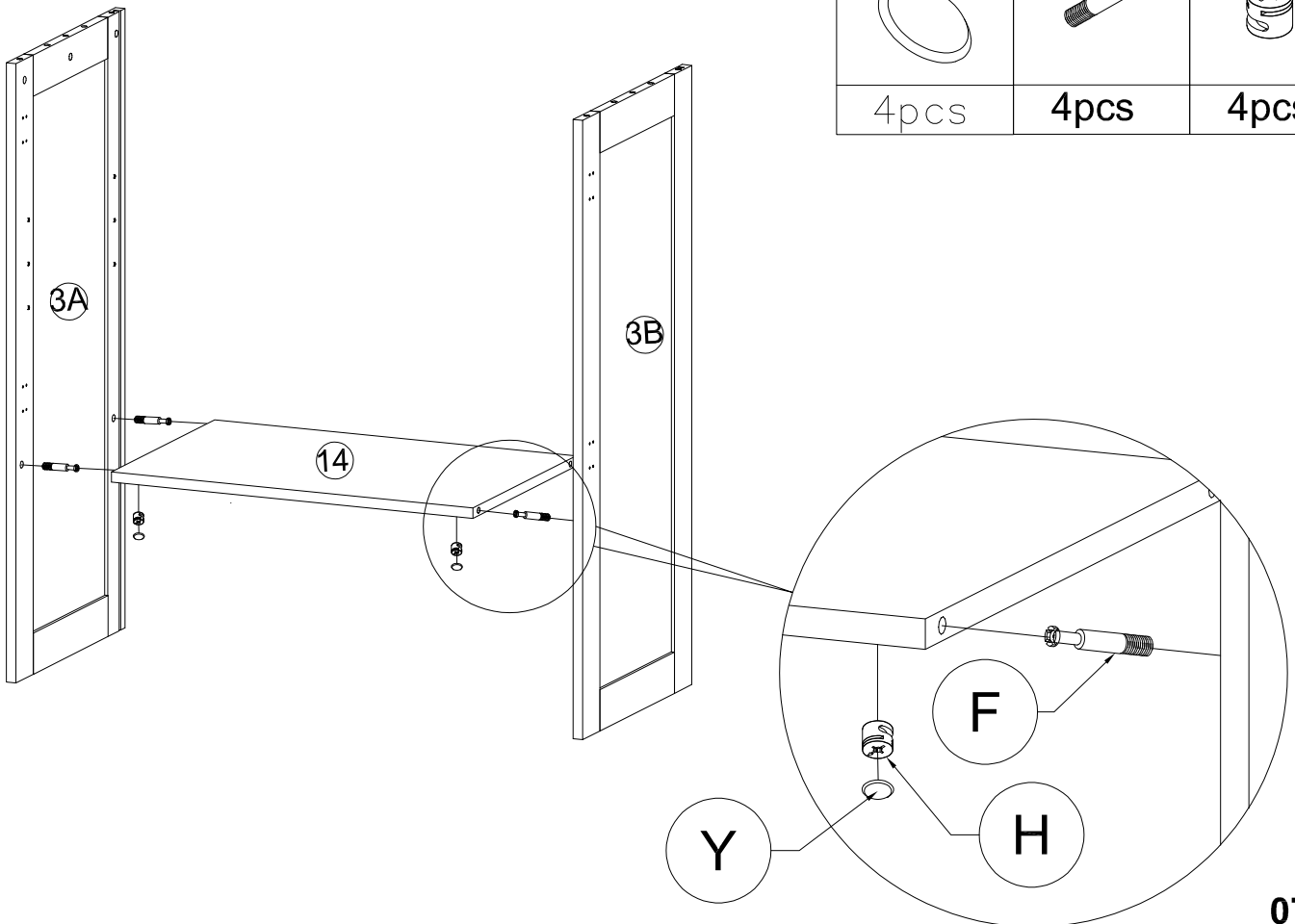



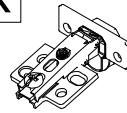
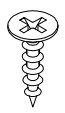

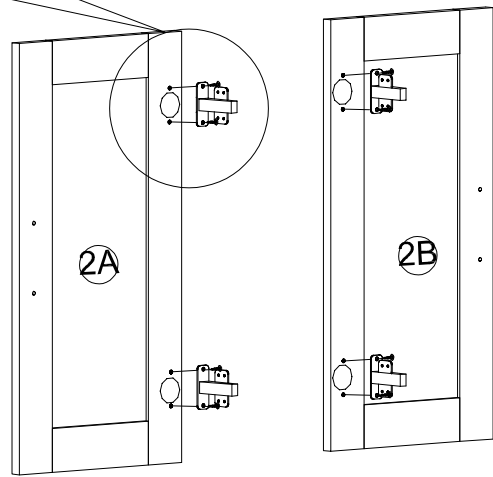
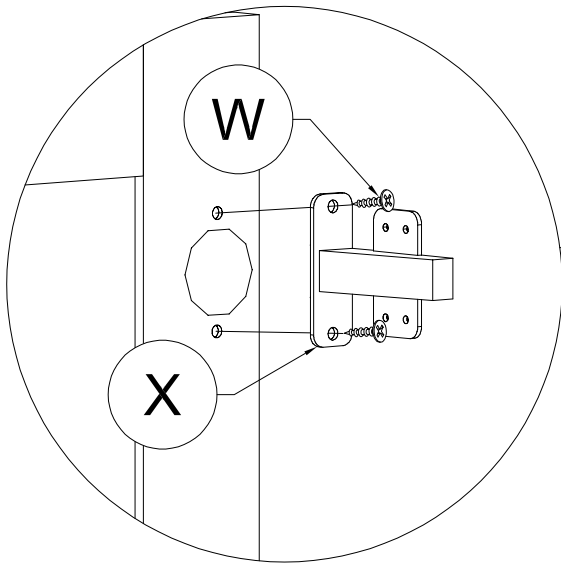

# STEP 6: Following below illustration:

X		W	
	4pcs		8pcs

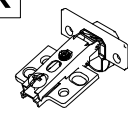
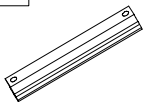

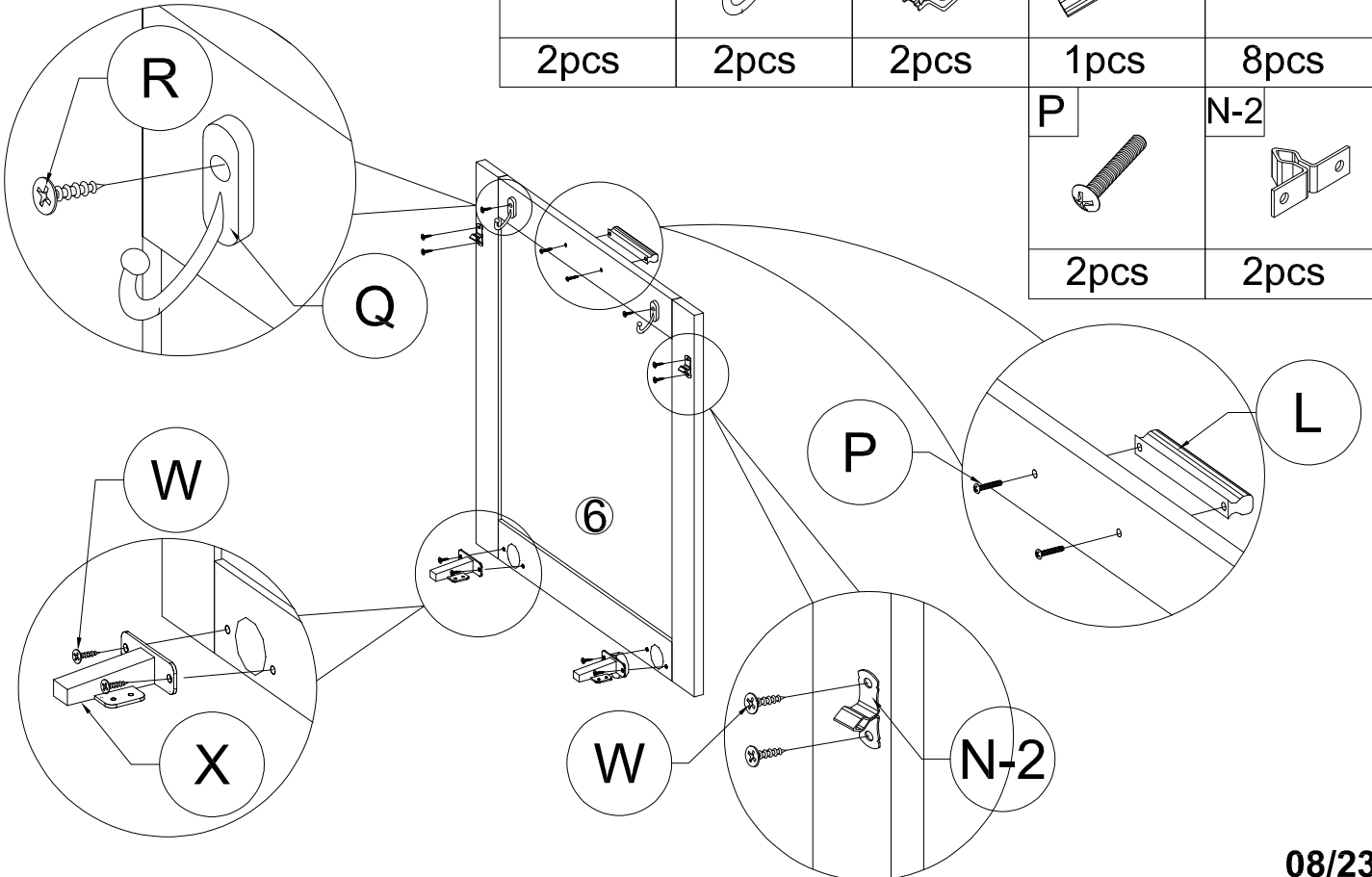

# STEP 7: Following below illustration:

R		Q		X		L		W	
	2pcs		2pcs		2pcs		1pcs		8pcs
						P		N-2	
							2pcs		2pcs

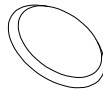
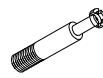

# STEP 8: Following below illustration:

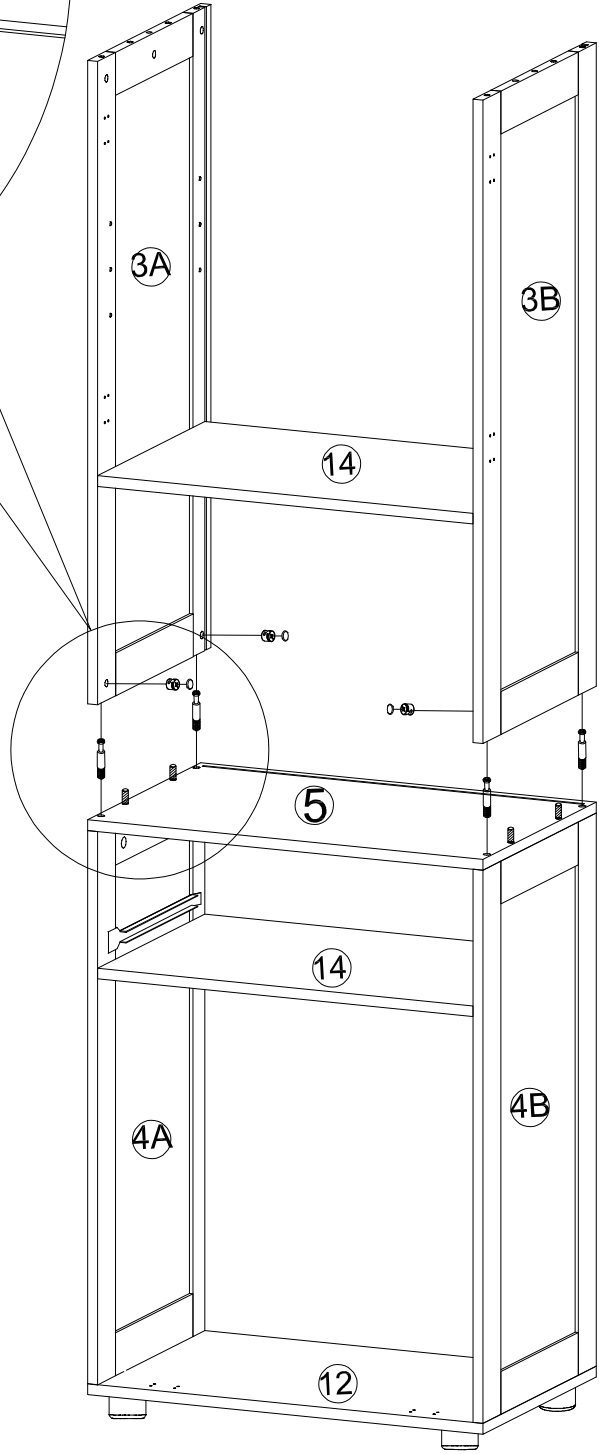
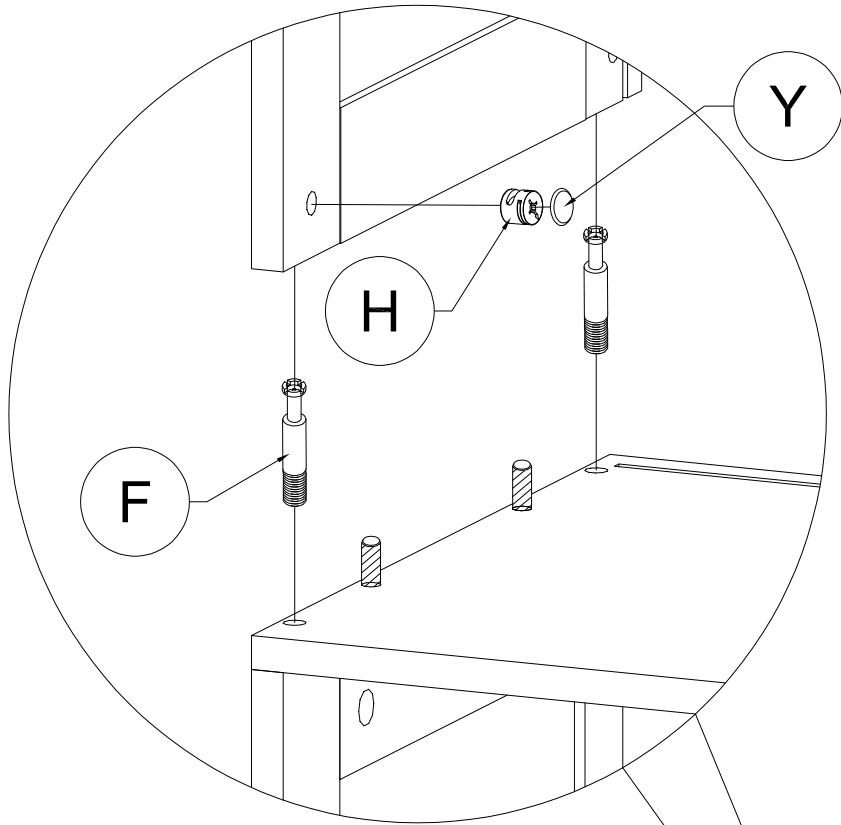

Y	F	H
		
4pcs	4pcs	4pcs

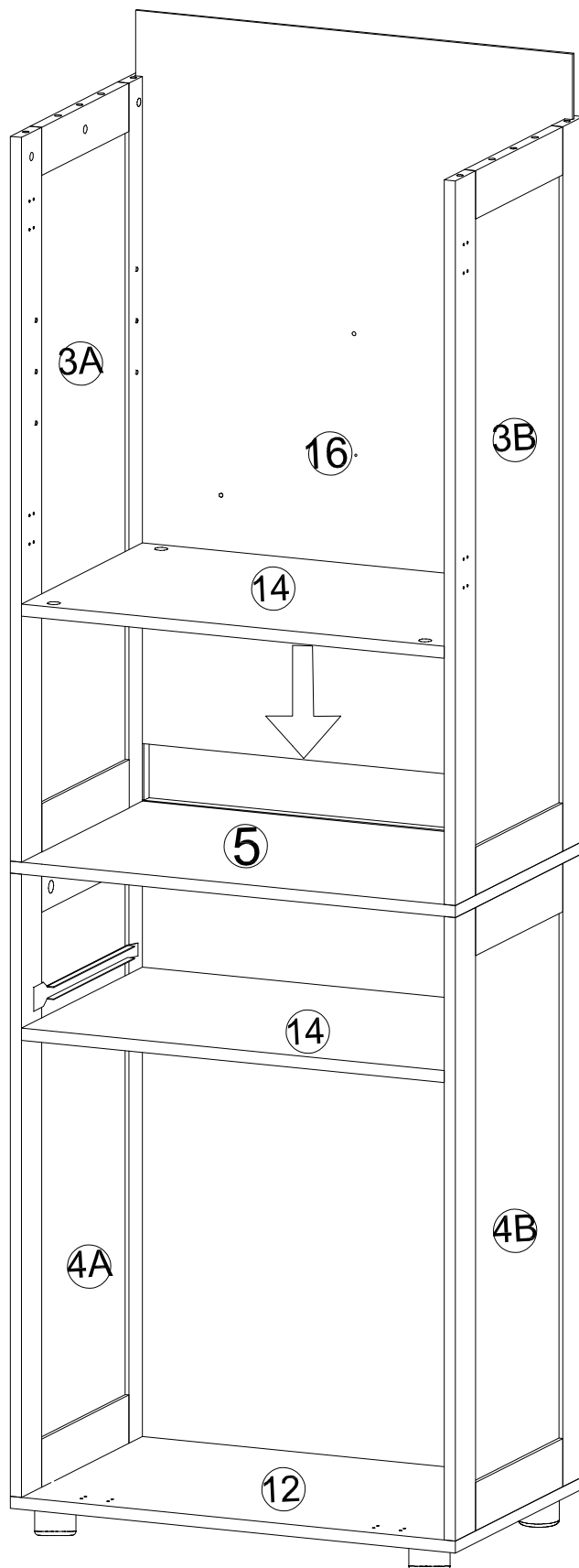

**STEP 9:** Following below illustration:



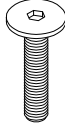

# STEP 10: Following below illustration:

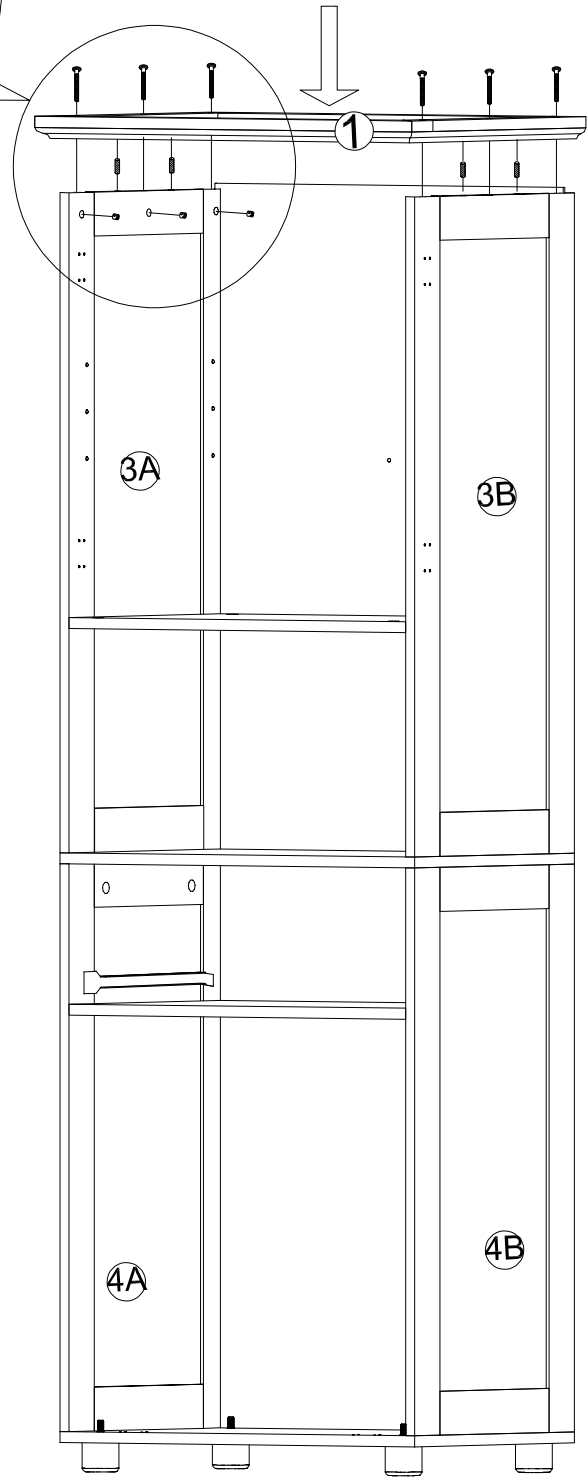
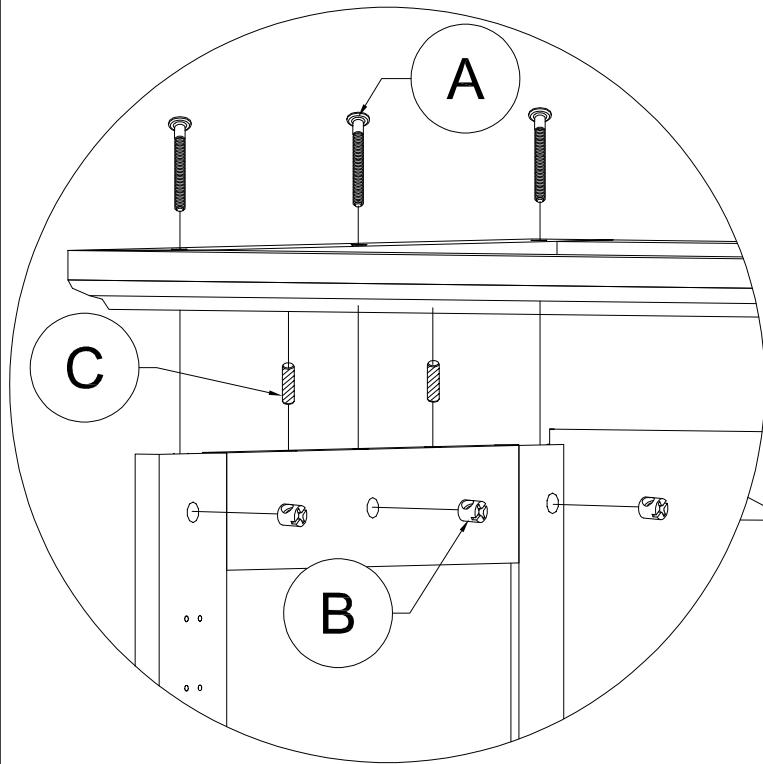
<b>A</b> 	<b>C</b> 	<b>B</b> 
6pcs	4pcs	6pcs

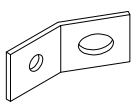

# STEP 11: Following below illustration:

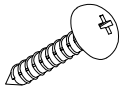
W	M-2	M-5	D
			
6pcs	2pcs	2pcs	18pcs

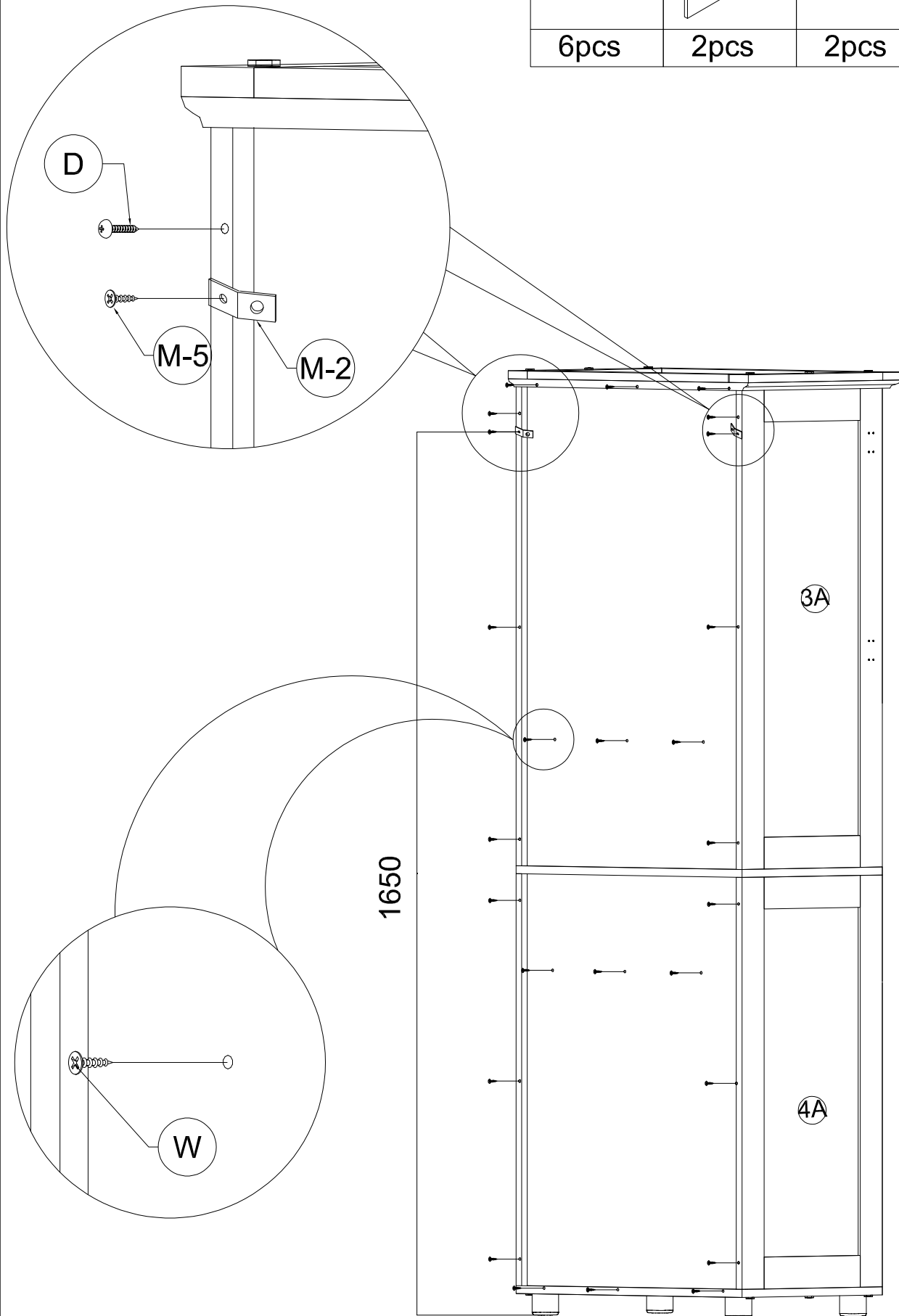

# STEP 12: Following below illustration:

W



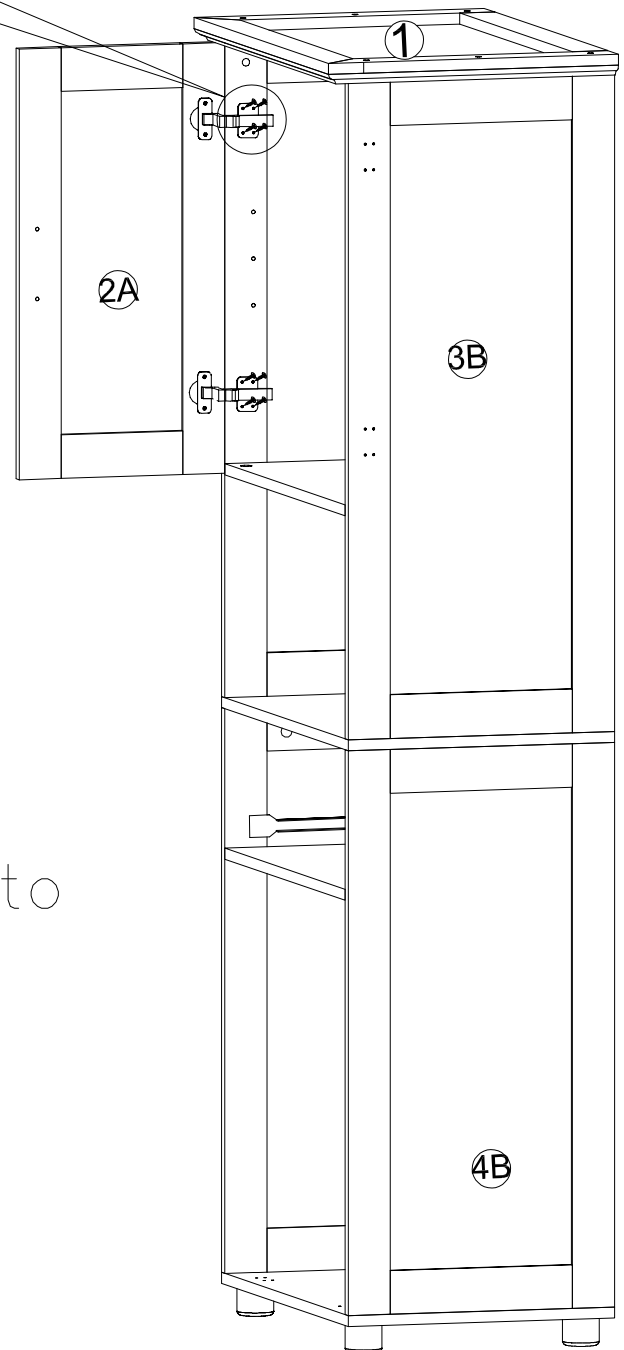
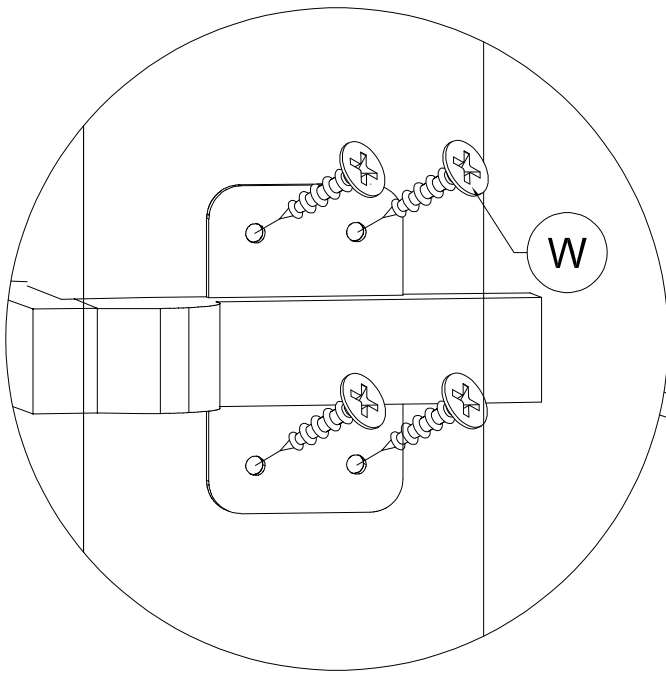

16pcs

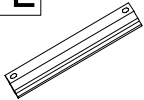

Scan the QR code to adjust the cabinet door clearance as desired.

# STEP 13: Following below illustration:

<b>P</b> 	<b>L</b> 	<b>I</b> 
4pcs	2pcs	4pcs

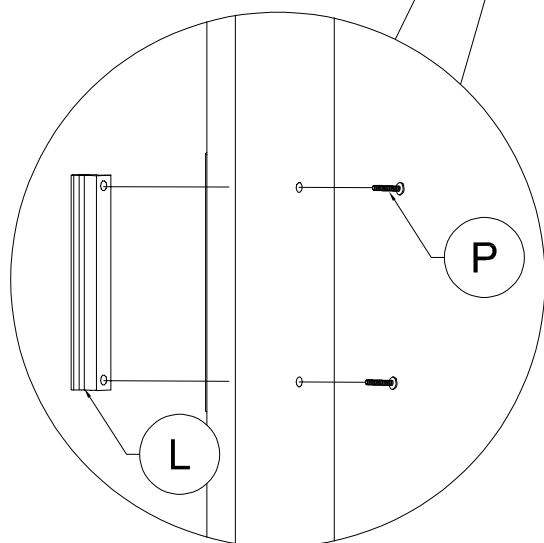
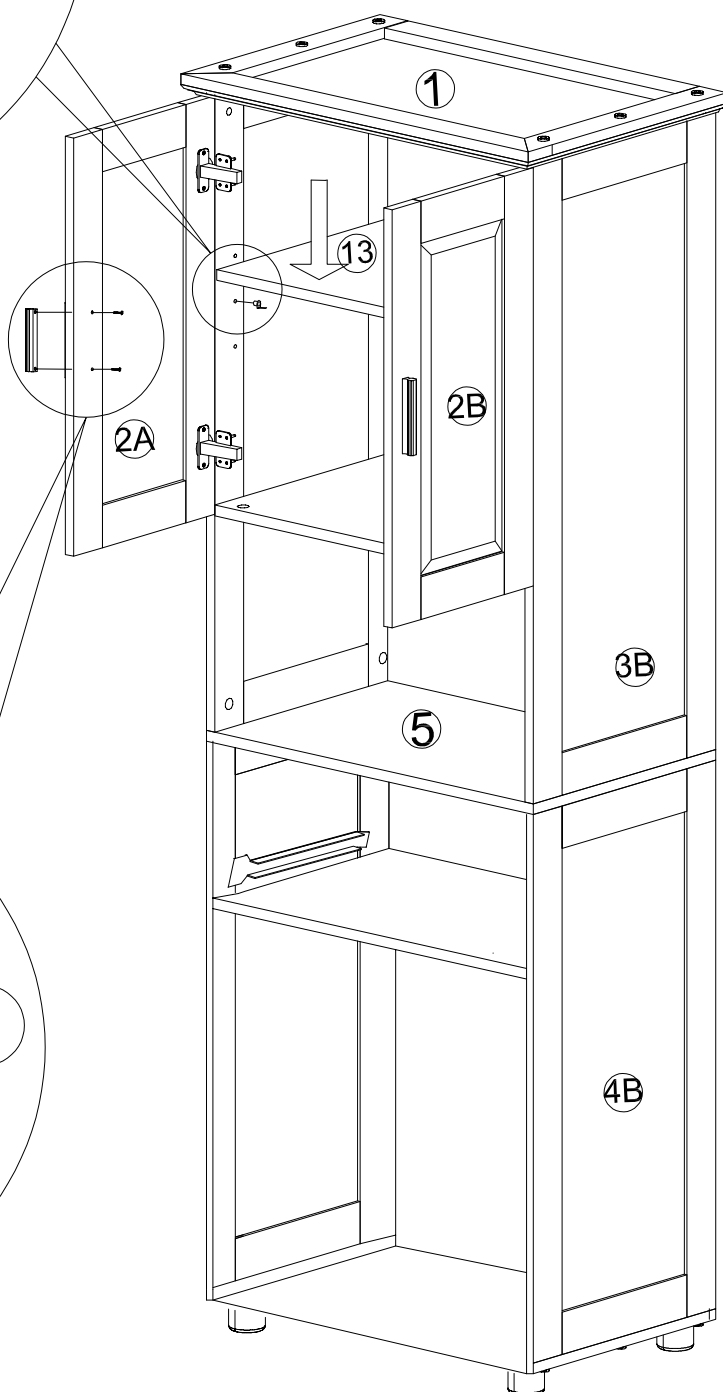
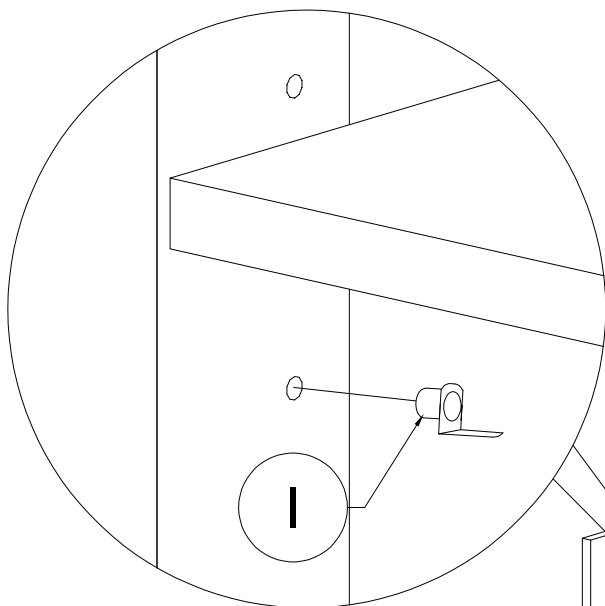

# STEP 14:

Following below illustration:

Z



4pcs

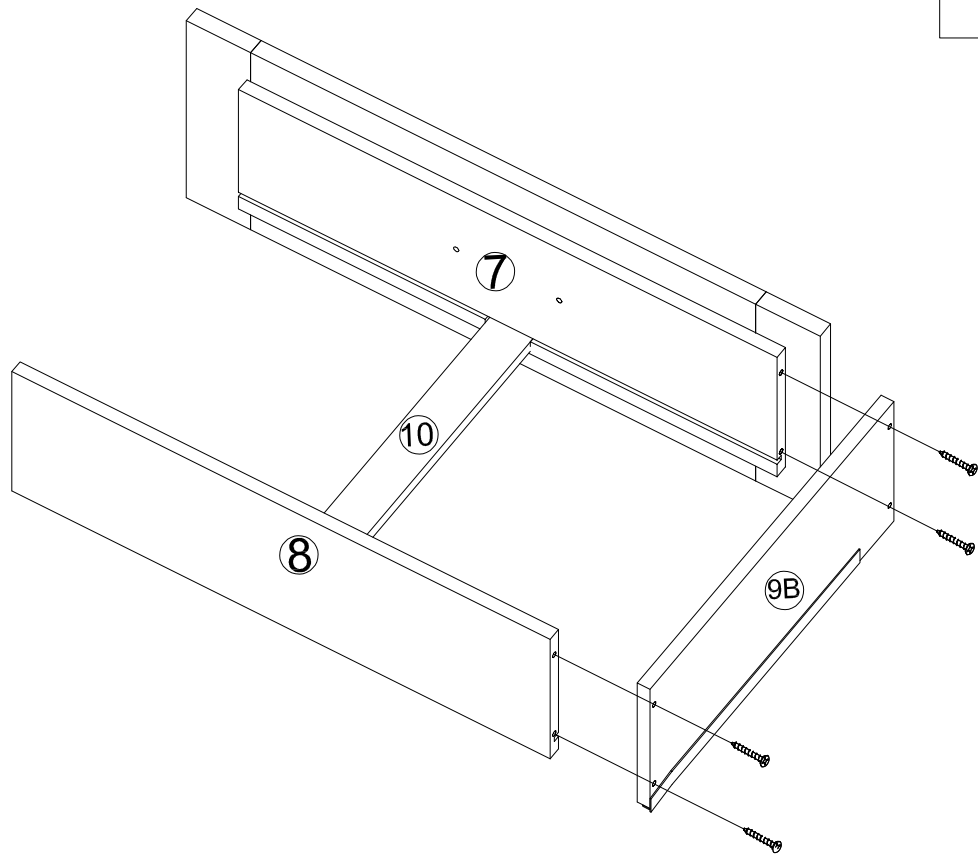

# STEP 15:

Following below illustration:

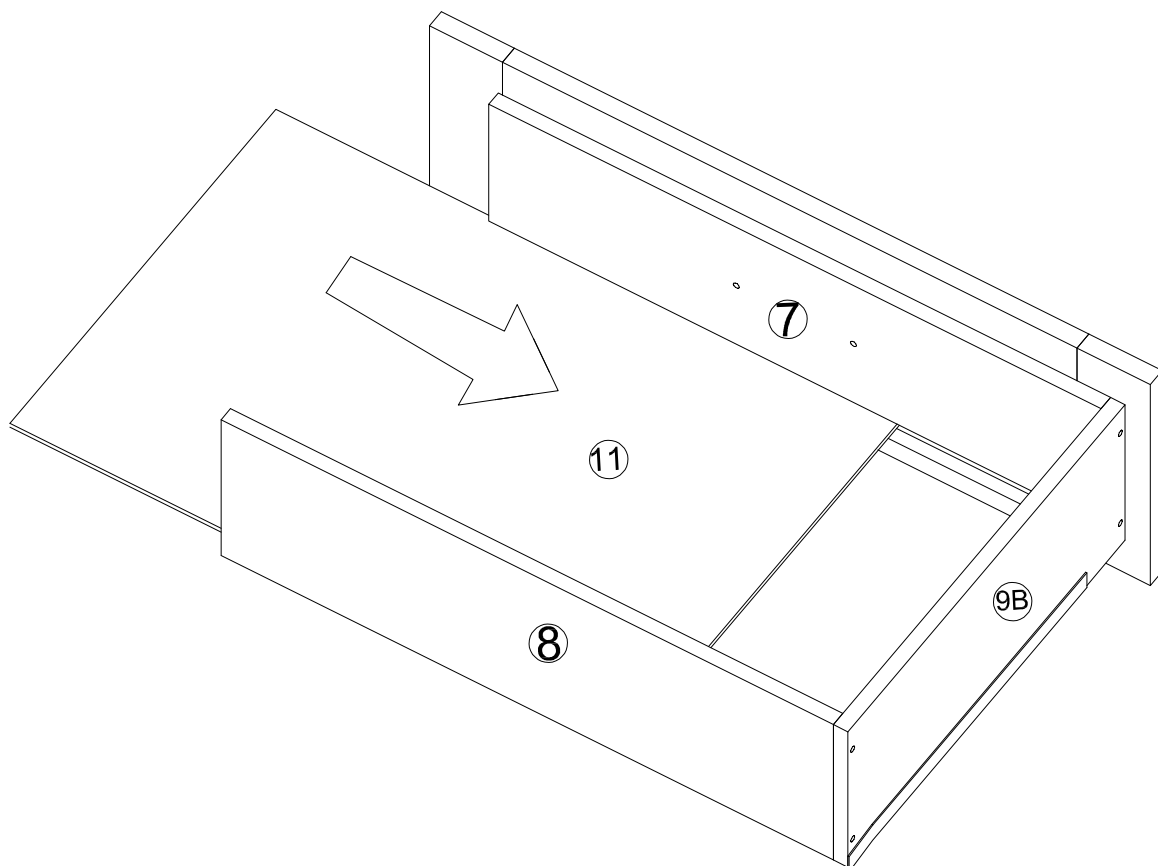

# STEP 16: Following below illustration:

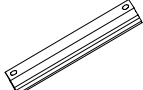
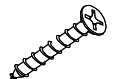
S	L	Z
		
2pcs	1pcs	4pcs

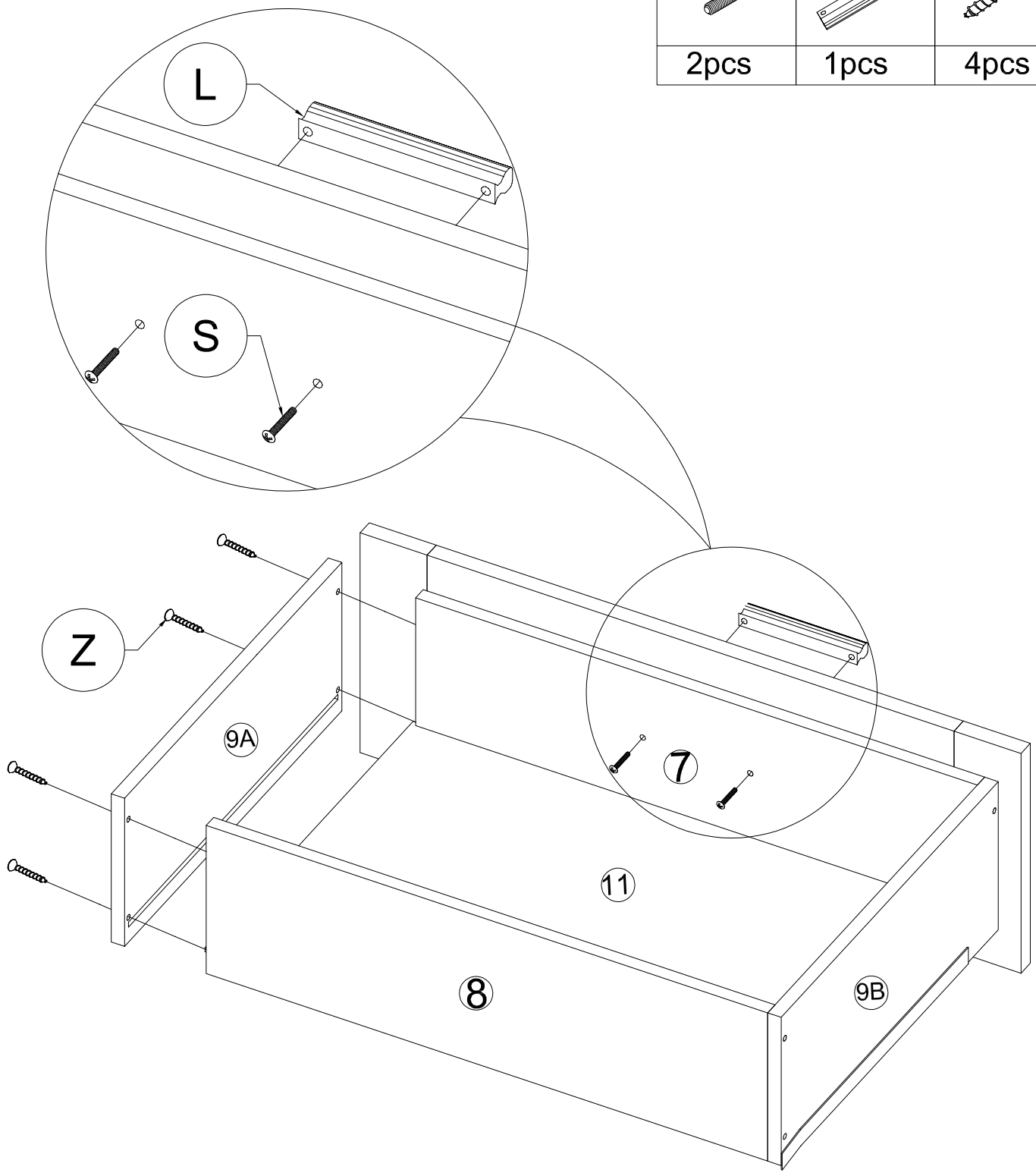

# STEP 17:

Following below illustration:

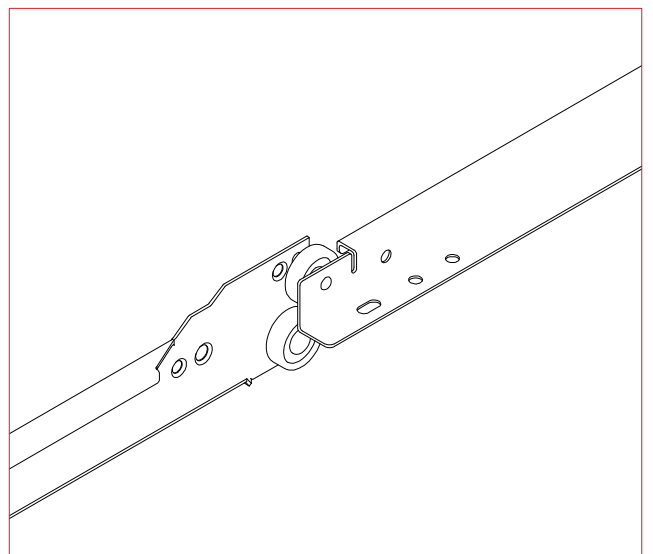
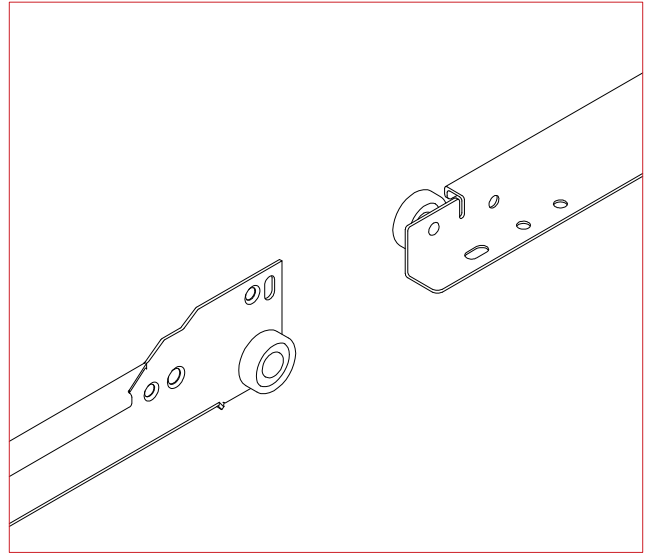
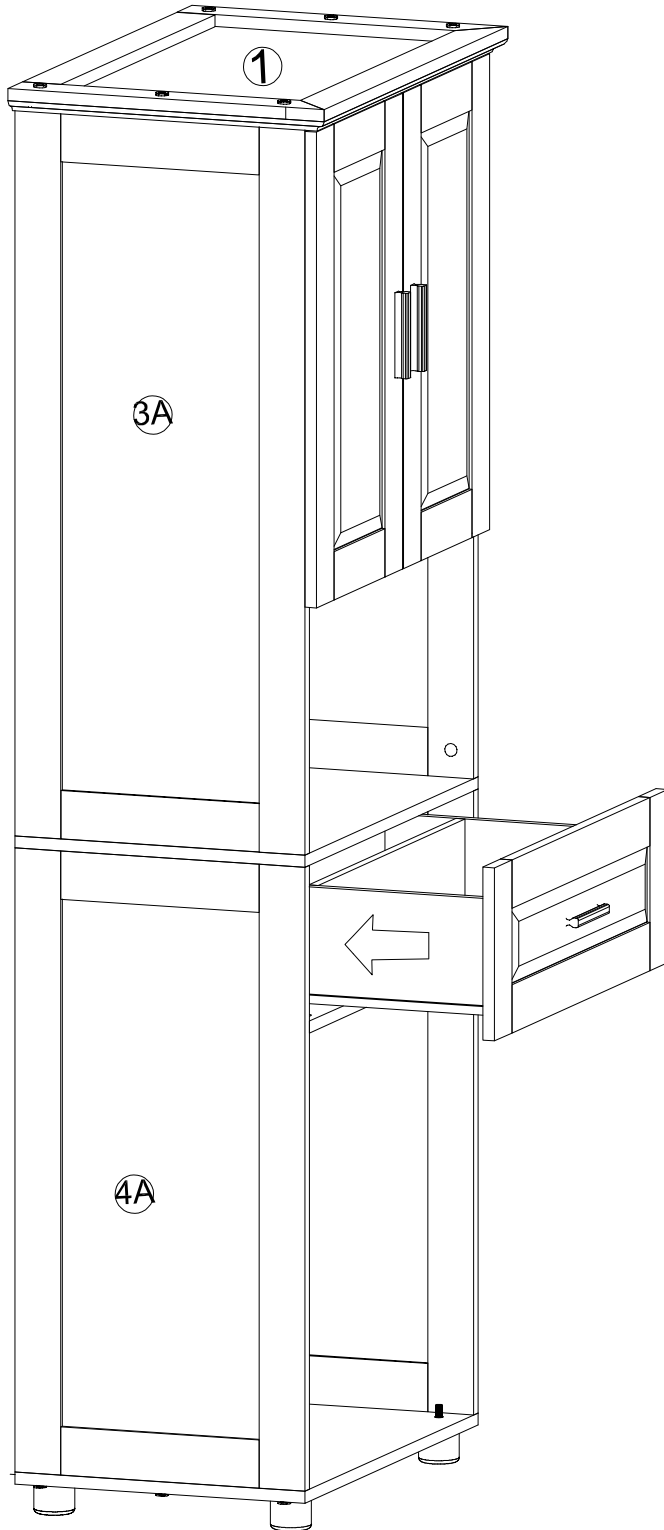

# STEP 18:

Following below illustration:

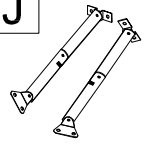
W	J
	
4pcs	1 set

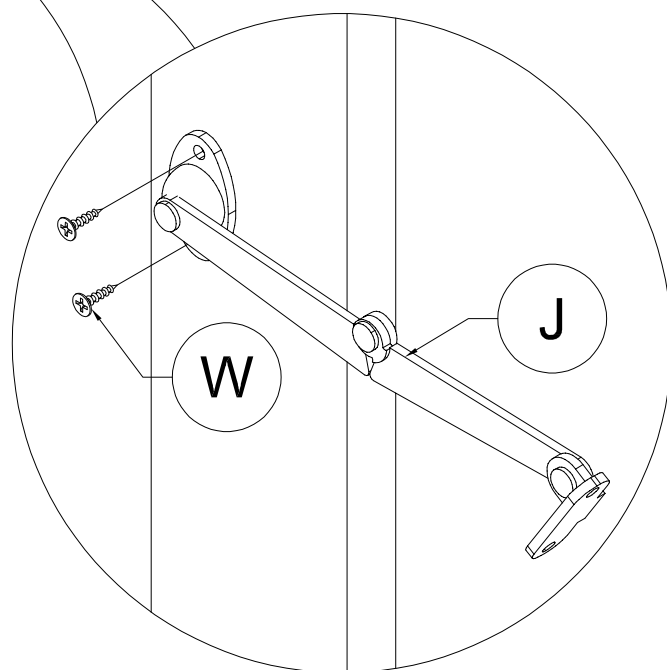
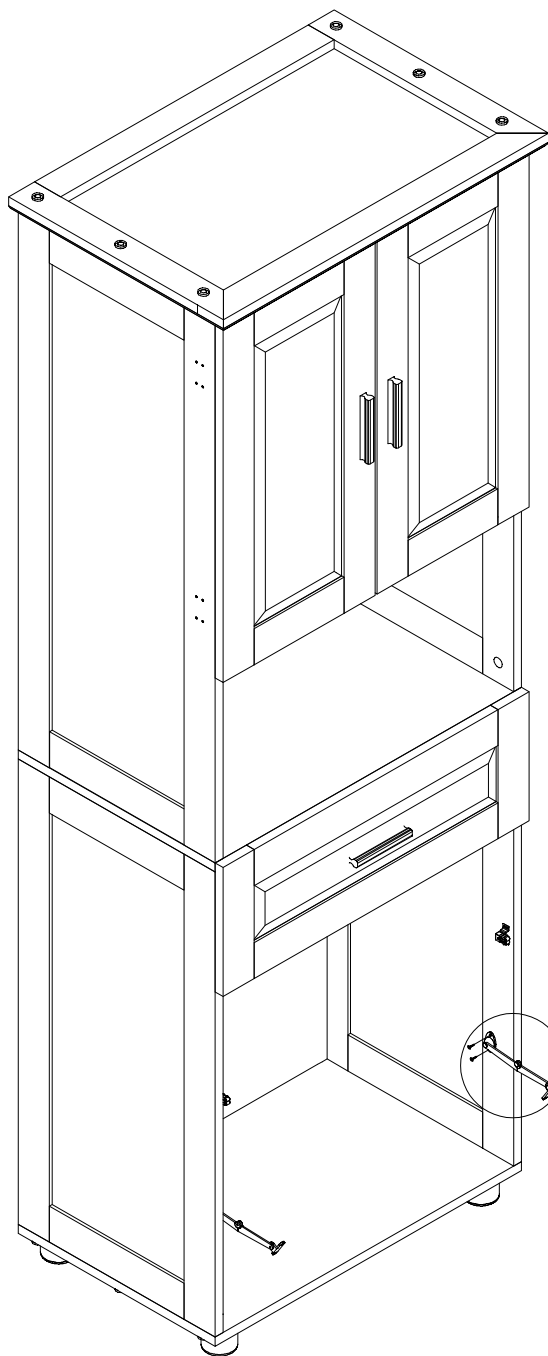

# STEP 19:

Following below illustration:

N.1

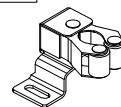

2pcs

W



16pcs

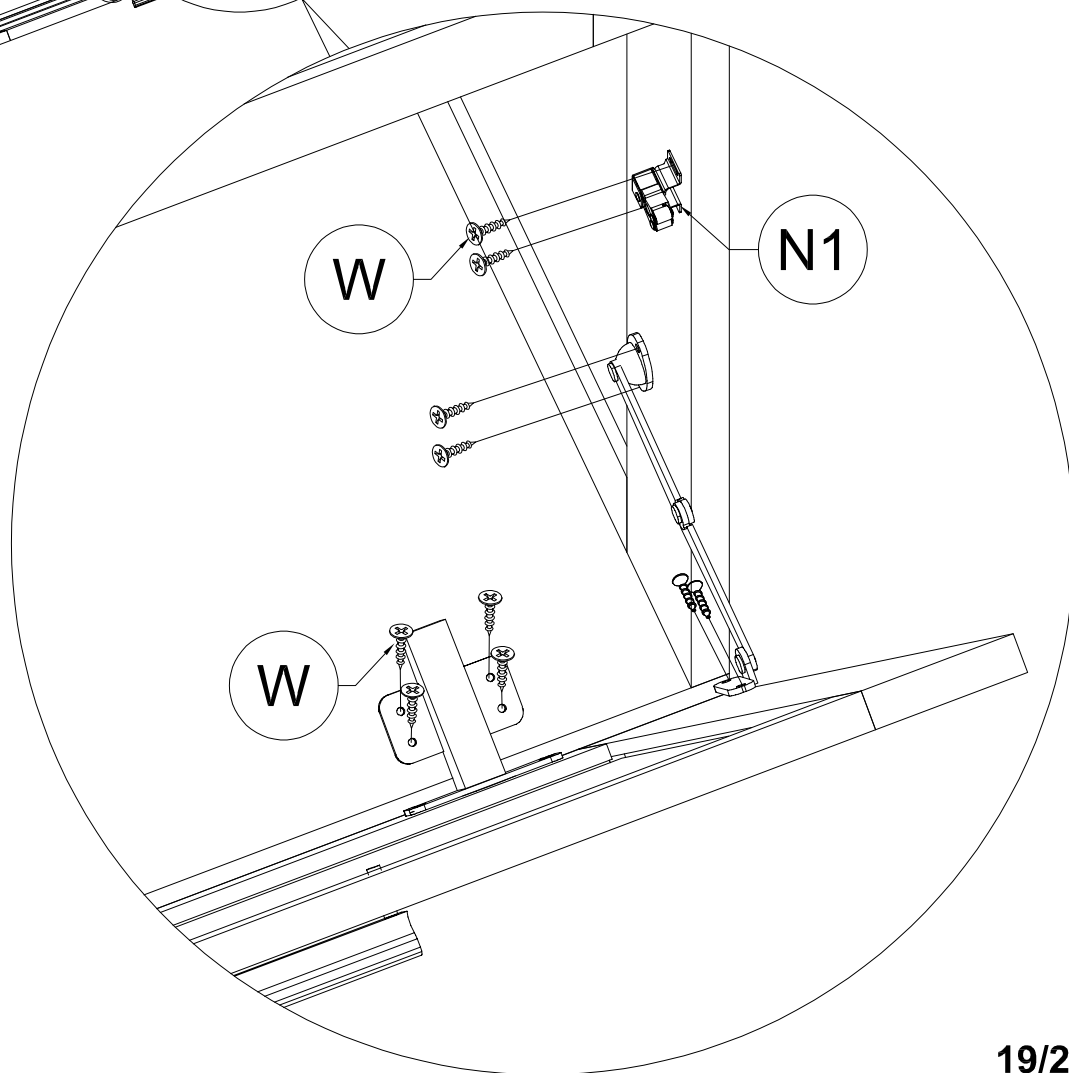
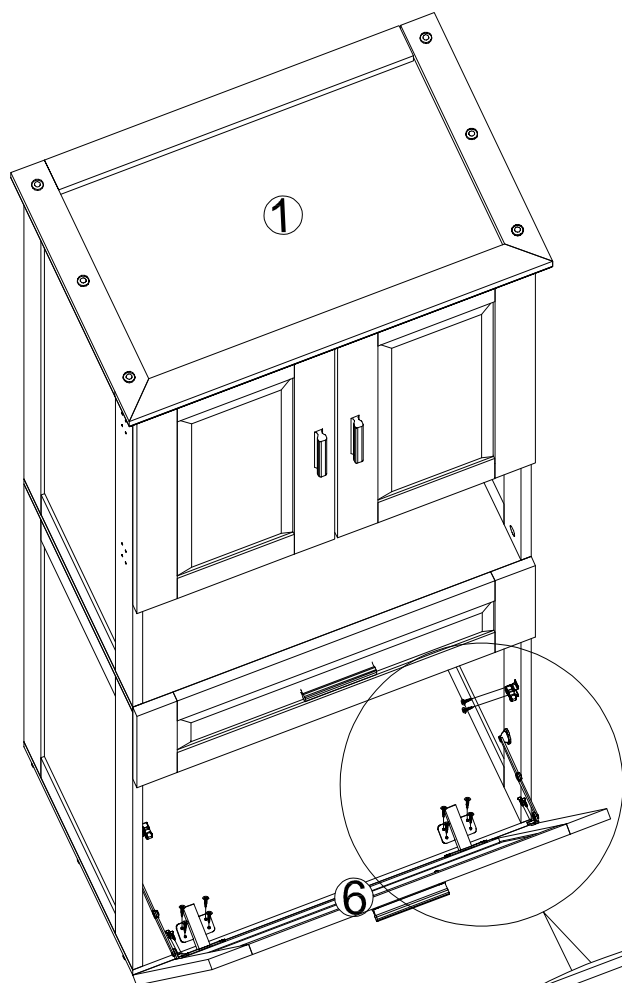

# STEP 20:

Following below illustration:

T

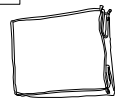

1pc

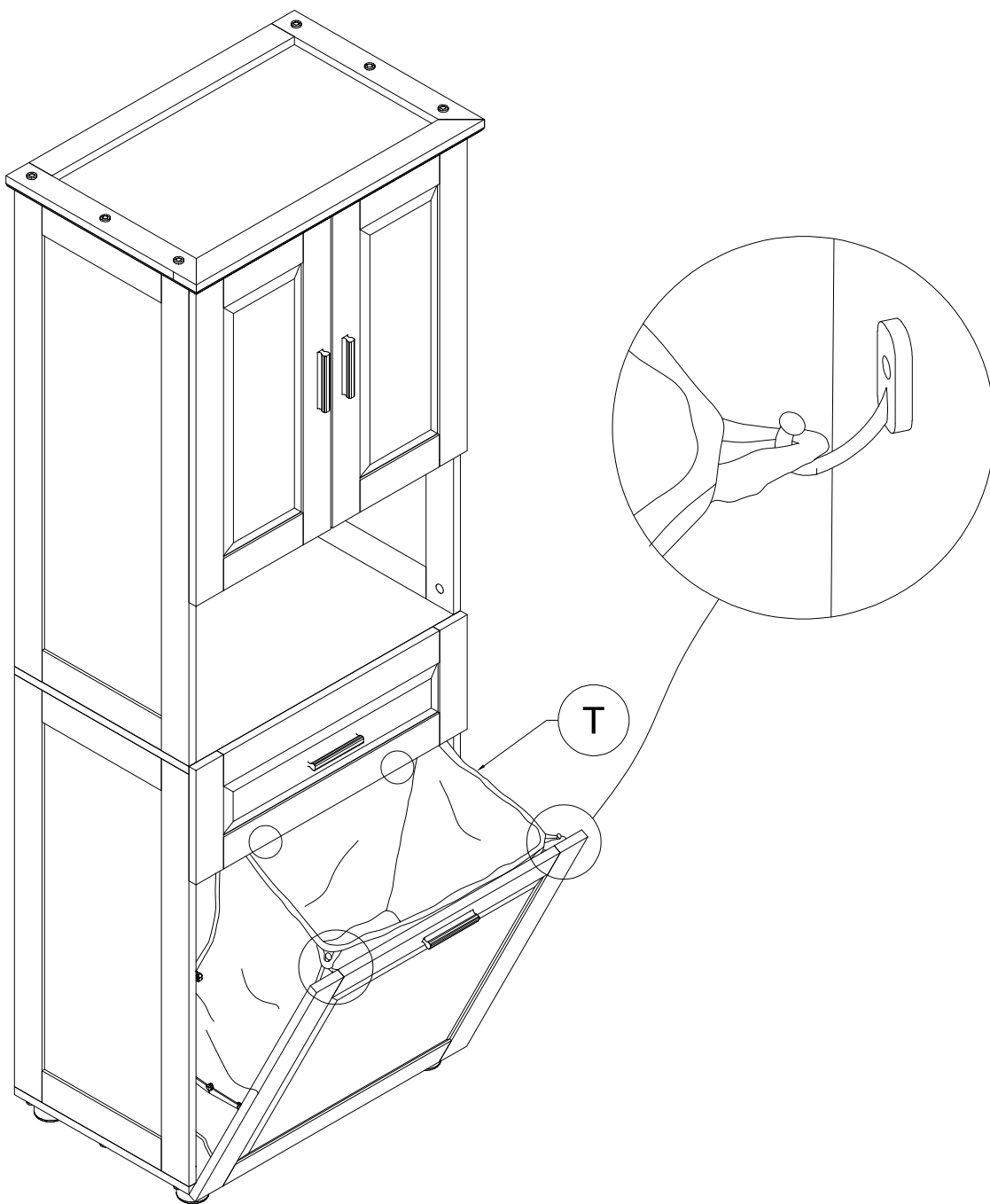

# STEP 21: Following below illustration:

M-2

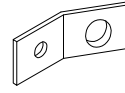

2pcs

M-4



2pcs

M-3



2pcs

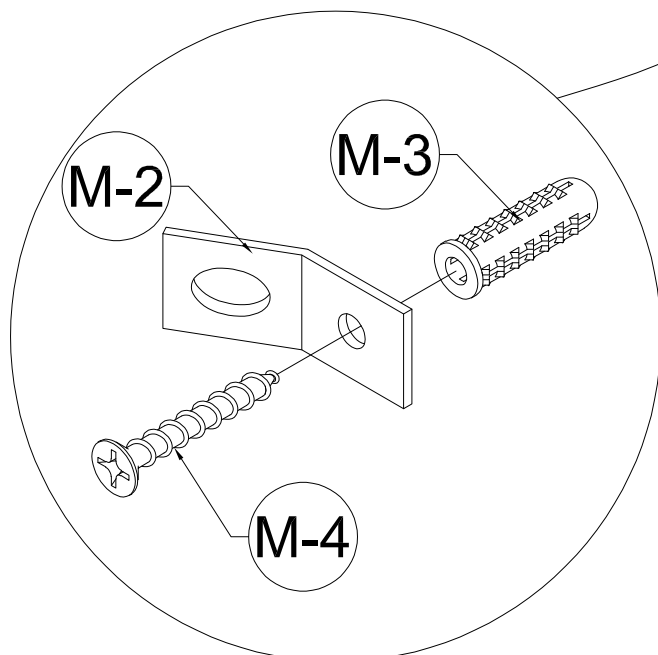
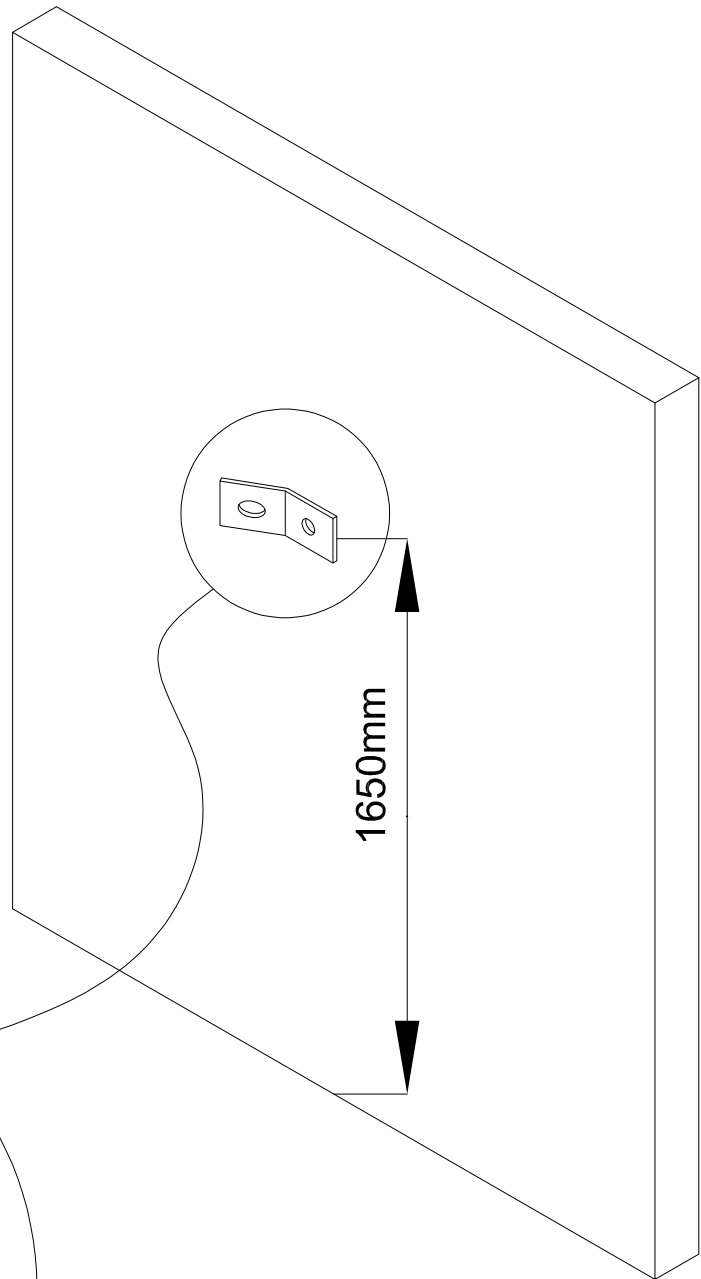

# STEP 22:

Following below illustration:

M-1



2pcs

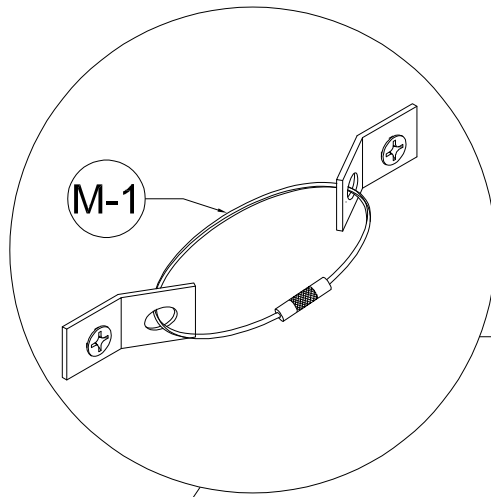

M-1

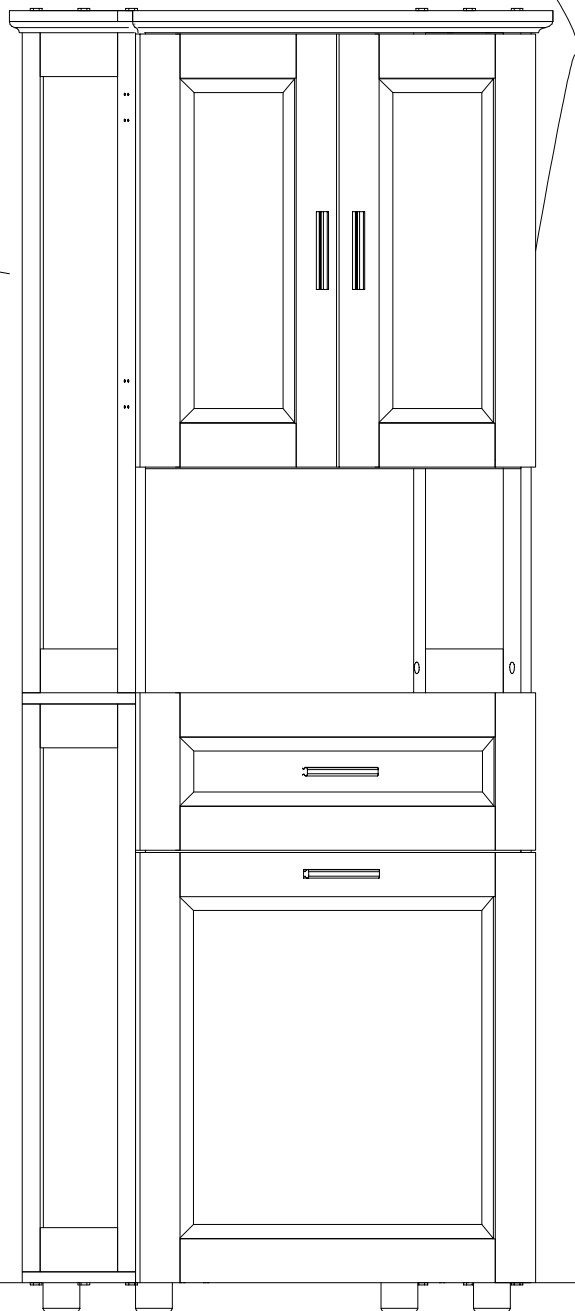

# FINISH

