

# ASSEMBLY GUIDE



**Important - Please read these instructions fully before starting assembly**



**SAFETY AND  
CARE ADVICE**



**NO POWER TOOLS**

**SAFETY AND CARE ADVICE**

- Check you have all the components and tools listed.
- Remove all fittings from the plastic bags and separate them into their groups.
- We do not recommend the use of power drills/drivers for inserting screws, as this could damage the unit. Only use hand screwdrivers and Allen keys.
- Keep children and animals away from the work area, small parts could cause choking if swallowed.
- Make sure you have enough space to layout the parts before starting.
- Assemble the item as close to its final position (in the same room) as possible.
- Do not overtighten the nuts to avoid causing damage to the threads.
- Only clean using a damp cloth and mild detergent, do not use bleach or abrasive cleaners.
- From time to time check that there are no loose screws on this unit
- This product should not be discarded with household waste. Take to your local authority waste disposal centre

## IMPORTANT INFORMATION



30 MINUTE  
BUILD



ONE  
PERSON



MAXIMUM  
CAPACITY  
130Kg

PLEASE CHECK CAREFULLY AND MAKE SURE YOU HAVE ALL FITTINGS AND TOOLS LISTED BELOW BEFORE YOU START.

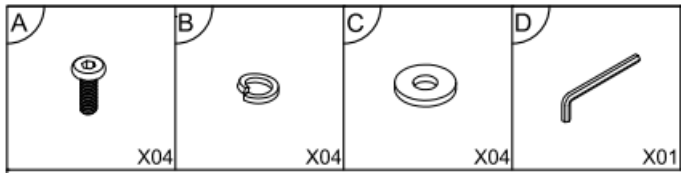

**NOTE:** The quantities above are the correct amount to complete the assembly. In some cases more fittings may be supplied than are required.

## STEP 1

Use a clean, flat, soft surface to avoid any bumps or scratches.

Place seat base upside down - you may find it helpful to use the corner of a table or desk. Attach the leg frame. Align the pre-drilled holes and connect using 1x washer [C] + spring washer [B] + bolt [A] per hole - 4 in total. Tighten with Allen key [D].

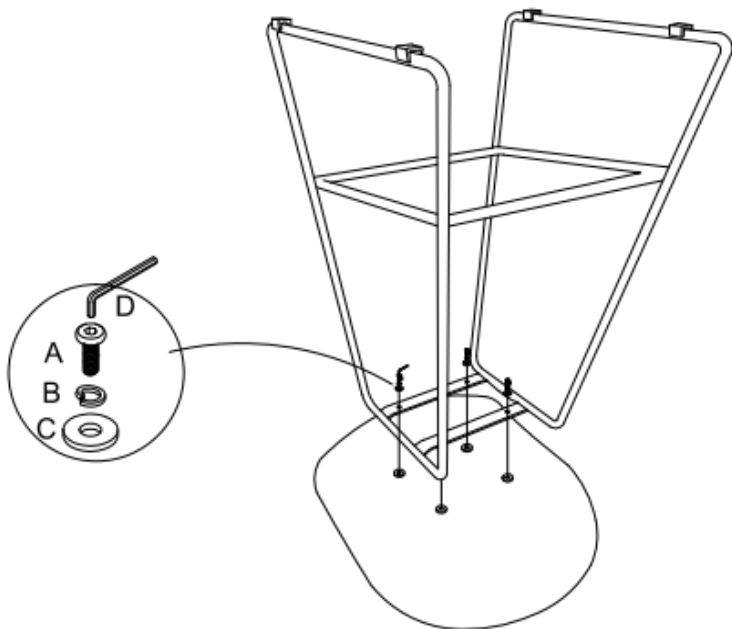

## STEP 2

Turn the stool over so it rests on its legs. Check stability. Your stool is now ready to use!

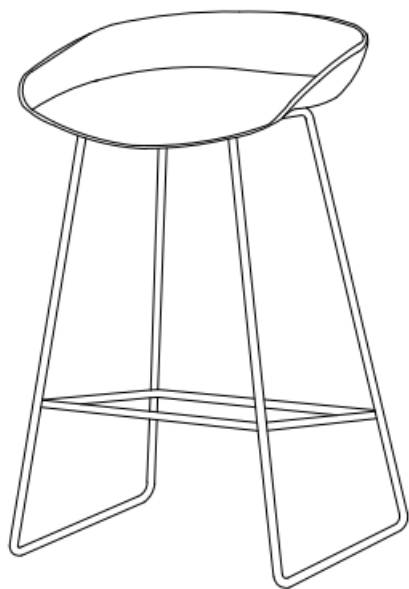



## OUR 2 YEAR\* GUARANTEE

our products come with a 2 year guarantee  
to give you peace of mind shopping

\*excludes some garden furniture items  
which have a 1 year guarantee



## WHAT THE GUARANTEE COVERS

---



### PRE-INSERTED FIXINGS

e.g. lose metal threads



### FAULTY JOINTS

e.g. legs bending



### EXTERNAL FIXING FAULTS

e.g. bonding/glue



### STRUCTURAL INTEGRITY

e.g. the frame of the  
product