



X 2

Outdoor Storage Shed

Model: CC70

NO.:



HELP CENTER

Have questions about this product? Contact us, and we'll assist you!

● Customer Support Email:

support.us@soforoom.com

* Upon receiving your email, we'll respond within **48** working hours.

HILFEZENTRUM

Haben Sie Fragen zu diesem Produkt? Kontaktieren Sie uns, wir helfen Ihnen weiter!

● E-Mail des Kundensupports: support.us@soforoom.com

* Nach Erhalt Ihrer E-Mail antworten wir innerhalb von **48** Arbeitsstunden.

CENTRE D'AIDE

Vous avez des questions sur ce produit? Contactez-nous et nous vous aiderons!

● E-mail du service client : support.us@soforoom.com

* Dès réception de votre email, nous vous répondrons dans les **48** heures ouvrées.

CENTRO ASSISTENZA

Hai domande su questo prodotto? Contattaci e ti aiuteremo!

● E-mail dell'assistenza clienti: support.us@soforoom.com

* Dopo aver ricevuto la tua email, ti risponderemo entro **48** ore lavorative.

CENTRO DE AYUDA

¿Tienes preguntas sobre tu producto? Ponte en contacto con nosotros y te ayudaremos.

● Correo electrónico de atención al cliente: support.us@soforoom.com

*Al recibir tu correo electrónico, te responderemos en un plazo de **48** horas laborables.

FAQ

Q1: What should I do if the product I received is damaged or incorrect?

A1: If you've received a damaged, incorrect, or incomplete product, please reach out to our Customer Support Center at support.us@soforoom.com. Include your order number and photos.

Q2: What should I do if I encounter problems during installation?

A2: If you encounter any installation issues, please email to support.us@soforoom.com, attach a detailed description of the problem, we will provide you for professional technical support.

Q3: How do I apply a return?

A3: You can initiate a return within 30 days of purchase. Email us at support.us@soforoom.com with your order number and the reason for return. We'll guide you through the process.

Note:

- Please contact us before returning the product to avoid any complications.
- Ensure the product is returned in its original packaging with all accessories included.

FAQ

F1: Wenn ich ein beschädigtes, falsches oder unvollständiges Produkt erhalten habe, was soll ich tun?

A1: Wenn Sie ein beschädigtes, falsches oder unvollständiges Produkt erhalten haben, wenden Sie sich bitte an unser Kundensupport-Center unter support.us@soforoom.com. Geben Sie Ihre Bestellnummer und Fotos an.

F2: Was soll ich tun, wenn während der Installation Probleme auftreten?

A2: Wenn bei der Installation Probleme auftreten, senden Sie bitte eine E-Mail an support.us@soforoom.com und fügen Sie eine detaillierte Beschreibung des Problems bei. Wir bieten Ihnen dann professionellen technischen Support.

F3: Wie beantrage ich eine Rücksendung?

A3: Innerhalb von 30 Tagen nach dem Kauf können Sie eine Rückgabe veranlassen. Senden Sie uns eine E-Mail an support.us@soforoom.com mit Ihrer Bestellnummer und dem Grund der Rücksendung. Wir begleiten Sie durch den Prozess.

Notiz:

- Bitte kontaktieren Sie uns vor der Rücksendung des Produkts, um Komplikationen zu vermeiden.
- Stellen Sie sicher, dass das Produkt in der Originalverpackung mit sämtlichem Zubehör zurückgegeben wird.

FAQ

Q1 : Que dois-je faire si le produit que j'ai reçu est endommagé ou incorrect ?

A1 : Si vous avez reçu un produit endommagé, incorrect ou incomplet, veuillez contacter notre Centre de support client à support.us@soforoom.com. Incluez votre numéro de commande et des photos.

Q2 : Que dois-je faire si je rencontre des problèmes lors de l'installation ?

A2 : Si vous rencontrez des problèmes d'installation, veuillez envoyer un e-mail à support.us@soforoom.com. Joindre une description détaillée du problème, nous vous fournirons une assistance technique professionnelle.

Q3 : Comment puis-je appliquer un retour ?

A3 : Vous pouvez lancer un retour dans les 30 jours suivant l'achat. Envoyez-nous un e-mail à support.us@soforoom.com avec votre numéro de commande et le motif du retour. Nous vous guiderons tout au long du processus.

Note:

- Veuillez nous contacter avant de retourner le produit pour éviter toute complication.
- Assurez-vous que le produit est retourné dans son emballage d'origine avec tous les accessoires inclus.

FAQ

Q1: Cosa devo fare se il prodotto che ho ricevuto è danneggiato o errato?

R1: Se hai ricevuto un prodotto danneggiato, errato o incompleto, contatta il nostro Centro di assistenza clienti all'indirizzo support.us@soforoom.com. Includi il numero dell'ordine e le foto.

Q2: Cosa devo fare se riscontro problemi durante l'installazione?

R2: Se riscontri problemi di installazione, invia un'e-mail a support.us@soforoom.com. allega una descrizione dettagliata del problema, ti forniremo supporto tecnico professionale.

Q3: Come posso applicare un reso?

R3: Puoi avviare un reso entro 30 giorni dall'acquisto. Inviaci un'e-mail a support.us@soforoom.com con il numero dell'ordine e il motivo della restituzione. Ti guideremo attraverso il processo.

Nota:

- Vi preghiamo di contattarci prima di restituire il prodotto per evitare complicazioni.
- Assicurarsi che il prodotto venga restituito nella sua confezione originale con tutti gli accessori inclusi.

PREGUNTAS FRECUENTES

P1: ¿Qué debo hacer si el producto que he recibido está dañado o es incorrecto?

R1: Si has recibido un producto dañado, incorrecto o incompleto, ponte en contacto con nuestro Centro de Atención al Cliente en **support.us@soforoom.com**. Incluye tu número de pedido y fotos que documenten el problema para que podamos ayudarte con la devolución o el cambio.

P2: ¿Qué debo hacer si encuentro problemas durante la instalación?

R2: Si tienes algún problema durante la instalación, por favor envía un correo electrónico a **support.us@soforoom.com**, adjuntando una descripción detallada del problema.

Te proporcionaremos soporte técnico profesional.

P3: ¿Cómo puedo solicitar una devolución?

R3: Puede iniciar una devolución en los 30 días siguientes a la compra. Envíenos un correo electrónico a **support.us@soforoom.com** con su número de pedido y el motivo de la devolución. Te guiaremos a través del proceso.

Nota:

- Póngase en contacto con nosotros antes de devolver el producto para evitar complicaciones.
- Asegúrate de devolver el producto en su embalaje original y con todos los accesorios incluidos.

Product Guide and Maintenance Instructions

EN

Thank you for purchasing our product! To ensure a smooth installation and a great user experience, we recommend that you carefully read the following guide and instructions before getting started.

Assembly Instructions

- Before starting assembly, sort and organize all parts and accessories. Check for any damaged or missing items. If you notice any issues, please contact us immediately.
- Choose a spacious, flat, and well-lit area to ensure safe and easy assembly.
- Wear gloves to protect your hands from sharp edges. Avoid assembling during strong winds, heavy rain, or storms.
- Refer to the provided diagrams for guidance. Align screws with pre-drilled holes and tighten them only after ensuring all parts are correctly positioned. For larger structures, we recommend having two or more people assist.
- Tighten screws and bolts carefully to avoid over-tightening. If any parts are damaged, contact us immediately.

Safety Warnings

- Keep small parts and tools out of reach of children during assembly.
- Do not sit, stand, or climb on the product. Ensure children do not play on or around the product.
- Avoid assembling or using the product in extreme weather conditions (e.g., strong winds, heavy rain, or storms).

Care and Maintenance

- Regular Inspections: Periodically check and tighten all fasteners (screws, bolts, etc.) to maintain stability.
- Cleaning: Clean regularly to prevent the buildup of dust, debris, or moisture.
- Weatherproofing: Apply weatherproof treatments (e.g., sealants or UV protectants) to extend the product's lifespan.
- Ventilation: Ensure proper ventilation to prevent moisture buildup, which can lead to mold or rust.
- Material Care: Clean with mild soap and water. Avoid using abrasive tools.
- Pest Control: Regularly inspect for pests (e.g., rodents or insects) and take preventive measures to keep them out.

By following these guidelines, you can enjoy a safe and pleasant experience with our product. Thank you for choosing us!

Produktleitfaden und Pflegehinweise

DE

Vielen Dank, dass Sie sich für unser Produkt entschieden haben! Damit die Montage reibungslos verläuft und Sie ein angenehmes Nutzungserlebnis haben, empfehlen wir, die folgenden Anweisungen und Hinweise vor Beginn sorgfältig zu lesen.

Montageanleitung

- Bevor Sie mit der Montage beginnen, sortieren und organisieren Sie alle Teile und Zubehörteile. Prüfen Sie auf beschädigte oder fehlende Komponenten. Falls Sie Probleme feststellen, kontaktieren Sie uns bitte umgehend.
- Wählen Sie einen geräumigen, ebenen und gut beleuchteten Bereich, um eine sichere und einfache Montage zu gewährleisten.
- Tragen Sie Handschuhe, um Ihre Hände vor scharfen Kanten zu schützen. Vermeiden Sie die Montage bei starkem Wind, starkem Regen oder Stürmen.
- Nutzen Sie die mitgelieferten Diagramme als Orientierung. Richten Sie die Schrauben an den vorgebohrten Löchern aus und ziehen Sie sie erst fest, nachdem alle Teile korrekt positioniert sind. Bei größeren Strukturen empfehlen wir, dass zwei oder mehr Personen beim Aufbau helfen.
- Ziehen Sie Schrauben und Bolzen vorsichtig fest, um ein Überdrehen zu vermeiden. Falls Teile beschädigt sind, kontaktieren Sie uns bitte sofort.

Sicherheitswarnungen

- Halten Sie während der Montage kleine Teile und Werkzeuge außerhalb der Reichweite von Kindern.
- Nicht auf das Produkt setzen, stehen oder klettern. Achten Sie darauf, dass Kinder nicht auf oder in der Nähe des Produkts spielen.
- Vermeiden Sie die Montage oder Nutzung des Produkts unter extremen Wetterbedingungen (z. B. starker Wind, starker Regen oder Stürme).

Pflege und Wartung

- Regelmäßige Inspektionen: Überprüfen und ziehen Sie regelmäßig alle Befestigungen (Schrauben, Bolzen usw.) nach, um die Stabilität zu gewährleisten.
- Reinigung: Reinigen Sie das Produkt regelmäßig, um die Ansammlung von Staub, Schmutz oder Feuchtigkeit zu verhindern.
- Witterungsschutz: Wenden Sie wetterfeste Schutzmaßnahmen an (z. B. Versiegelungen oder UV-Schutz), um die Lebensdauer des Produkts zu verlängern.
- Belüftung: Sorgen Sie für eine gute Belüftung, um Feuchtigkeitsansammlungen zu vermeiden, die zu Schimmel oder Rost führen können.
- Materialpflege: Reinigen Sie das Produkt mit mildem Seifenwasser. Verwenden Sie keine scheuernden Werkzeuge.
- Schädlingschutz: Untersuchen Sie das Produkt regelmäßig auf Schädlinge (z. B. Nagetiere oder Insekten) und ergreifen Sie vorbeugende Maßnahmen, um sie fernzuhalten.

Guida al Prodotto e Istruzioni per la Manutenzione

IT

Grazie per aver acquistato il nostro prodotto! Per garantire un'installazione senza intoppi e un'esperienza d'uso ottimale, ti consigliamo di leggere attentamente questa guida prima di iniziare.

Istruzioni di Montaggio

- Preparazione dei componenti: Prima di iniziare il montaggio, ordina e organizza tutte le parti e gli accessori. Verifica la presenza di eventuali danni ● componenti mancanti. In caso di problemi, contattaci immediatamente.
- Area di lavoro adeguata: Scegli un'area spaziosa, pianeggiante e ben illuminata per garantire un montaggio sicuro e agevole.
- Protezione personale: Indossa guanti per proteggere le mani dai bordi taglienti. Evita di assemblare il prodotto durante condizioni meteorologiche avverse (vento forte, pioggia intensa o tempeste).
- Consulta i diagrammi: Segui i diagrammi forniti per guidarti. Allinea le viti con i fori preforati e serrale solo dopo aver assicurato il corretto posizionamento di tutte le parti. Per strutture di grandi dimensioni, ti consigliamo di farti assistere da due o più persone.
- Attenzione al serraggio: Serra viti e bulloni con attenzione per evitare un eccessivo serraggio. In caso di parti danneggiate, contattaci subito.

Avvertenze di Sicurezza

● Sicurezza dei bambini:

Durante il montaggio, tieni piccoli componenti e strumenti fuori dalla portata dei bambini.

● Utilizzo corretto: Non sederti, non salire e non arrampicarti sul prodotto. Assicurati che i bambini non giochino sul prodotto o nelle sue vicinanze.

● Condizioni meteorologiche: Evita di assemblare o utilizzare il prodotto in condizioni estreme (es. vento forte, pioggia intensa o tempeste).

Cura e Manutenzione

● Ispezioni periodiche: Controlla e serra regolarmente tutti i fissaggi (viti, bulloni, ecc.) per mantenere la stabilità.

● Pulizia: Pulisci regolarmente il prodotto per evitare accumuli di polvere, detriti o umidità.

● Protezione dagli agenti atmosferici: Applica trattamenti impermeabilizzanti (es. sigillanti o protezioni UV) per prolungare la durata del prodotto.

● Ventilazione: Assicura una corretta ventilazione per prevenire ristagni di umidità, che potrebbero causare muffe o ruggine.

● Cura dei materiali: Utilizza acqua e sapone neutro per la pulizia. Evita strumenti abrasivi.

● Controllo parassiti: Ispeziona periodicamente la presenza di parassiti (es. roditori o insetti) e adotta misure preventive per tenerli lontani.

Seguendo queste indicazioni, potrai goderti il prodotto in totale sicurezza e comfort. Grazie per averci

Guide du Produit et Instructions d'Entretien

FR

Merci d'avoir acheté notre produit ! Pour une installation facile et une expérience utilisateur optimale, veuillez lire attentivement les consignes et instructions suivantes avant de commencer.

Instructions de Montage

- **Vérification des Pièces :** Avant de commencer l'assemblage, vérifiez que toutes les pièces et accessoires sont présents et en bon état. En cas de pièce manquante ou endommagée, contactez-nous immédiatement pour obtenir de l'aide.
- **Sécurité Avant Tout :** Nous vous recommandons de porter des gants pour éviter les coupures dues aux bords tranchants des panneaux pendant l'assemblage.
- **Espace de Travail :** Assemblez le produit dans un espace dégagé et suffisamment grand. Ne marchez pas sur les panneaux afin d'éviter tout risque de fissure ou de déformation.
- **Suivez les Schémas :** Référez-vous aux schémas fournis pour faciliter l'assemblage. Alignez d'abord toutes les vis avec les trous pré-perçés correspondants, puis serrez-les une par une une fois en place.
- **Attention au Serrage :** Lors du vissage, veillez à ne pas trop forcer. Si vous constatez un problème sur une pièce, contactez-nous immédiatement.

Consignes de Sécurité

- **Sécurité des Enfants :**

Ce produit ne convient pas aux enfants de moins de 3 ans. Pendant l'assemblage, gardez les petites pièces hors de leur portée. La surveillance d'un adulte est requise lorsque les enfants utilisent ce produit.

Limitations d'Utilisation

- **Surface Stable :**

Placez toujours le produit sur une surface plane et stable. Ne vous asseyez pas et ne montez pas dessus. Les enfants ne doivent pas grimper ni jouer sur le produit, car cela pourrait provoquer un basculement et entraîner des blessures graves.

Utilisation du Produit

- **Vérifications Finales :**

Après l'assemblage, assurez-vous que toutes les vis sont bien serrées et que le produit est stable avant de l'utiliser.

- **Usage Intérieur Uniquement :**

Ce produit est conçu uniquement pour une utilisation en intérieur. Nous ne sommes pas responsables des dommages causés par une utilisation inappropriée ou des modifications du produit.

Entretien du Produit

- **Conditions Environnementales :**

Évitez l'exposition directe au soleil, à la pluie ou à l'humidité afin de prévenir toute déformation, décoloration ou fissure. De plus, éloignez le produit des objets tranchants et des substances corrosives pour préserver sa surface.

Guía del Producto e Instrucciones de Cuidado

ES

¡Gracias por adquirir nuestro producto! Para garantizar una instalación sencilla y una excelente experiencia de uso, le recomendamos leer atentamente las siguientes instrucciones antes de comenzar.

Instrucciones de Montaje

- **Verificar las Piezas:** Antes de iniciar la instalación, revise todas las piezas y accesorios para asegurarse de que no haya daños ni faltantes. Si detecta algún problema, contáctenos de inmediato para recibir asistencia.
- **Seguridad Primero:** Para evitar cortes con los bordes afilados de los paneles durante el ensamblaje, recomendamos usar guantes.
- **Espacio de Trabajo Adecuado:** Ensamble el producto en un área amplia y despejada. Evite pisar los paneles para prevenir grietas o deformaciones.
- **Uso de los Diagramas:** Le sugerimos seguir los diagramas proporcionados para facilitar el proceso de montaje. Alinee todos los tornillos con los orificios pre-perforados correspondientes y, una vez que todo esté en su lugar, apriete cada tornillo uno por uno.
- **Cuidado con la Fuerza Aplicada:** Al apretar los tornillos, tenga cuidado con la cantidad de fuerza utilizada. Si encuentra alguna pieza dañada, contáctenos de inmediato.

Advertencias de Seguridad

- **Seguridad Infantil:**
Este producto no es apto para niños menores de 3 años. Durante el montaje, mantenga las piezas pequeñas fuera del alcance de los niños. Se recomienda la supervisión de un adulto cuando los niños utilicen el producto.

Limitaciones de Uso

- **Superficie Estable:**
Asegúrese de colocar el producto sobre una superficie plana. No se siente ni se pare sobre él. Los niños no deben trepar ni jugar en el producto, ya que esto podría provocar accidentes graves si se vuelca.

Uso del Producto

- **Verificación Final:**
Después del montaje, asegúrese de que todos los tornillos estén bien apretados y que el producto sea estable antes de usarlo.

- **Solo para Uso en Interiores:**

Este producto está diseñado exclusivamente para uso en interiores. No nos hacemos responsables de los daños causados por un uso inadecuado o modificaciones del producto.

Cuidado del Producto

- **Condiciones Ambientales:**

SITE PREPARATION | PRÉPARATION DU SITE | PREPARACIÓN DEL LUGAR | VORBEREITUNG DES AUFSTELLUNGORTES | VOORBEREIDING VAN HET TERREIN | PREPARAZIONE DEL LUOGO DI ASSEMBLAGGIO | PREPARAÇÃO DO LOCAL

Level the ground surface | Nivelez la surface du sol | Nivele la superficie del suelo | Ebenen Sie die Bodenoberfläche | Maak de bodem vlak | Livellare la superficie del terreno | Nivele a superfície do solo

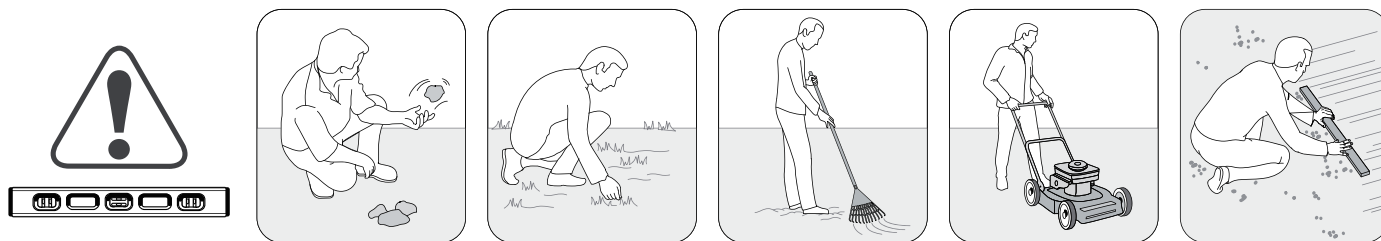

Recommendation: Construct a wooden or concrete base as a foundation | Recommandation: fabriquez une base en bois ou en béton en guise de fondation | Recomendación: construya una base de madera o de cemento a modo de cimiento | Empfehlung: Bauen Sie als Fundament eine Grundfläche aus Holz oder Beton | Aanbeveling: maak een houten of betonnen ondergrond als fundering | Raccomandazione: Costruire una base di legno o di cemento come fondamenta | Recomendação: Construa uma base de madeira ou de cimento como fundação

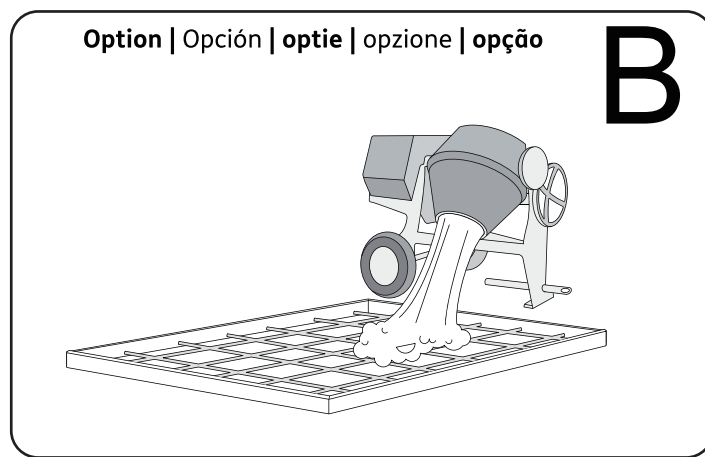
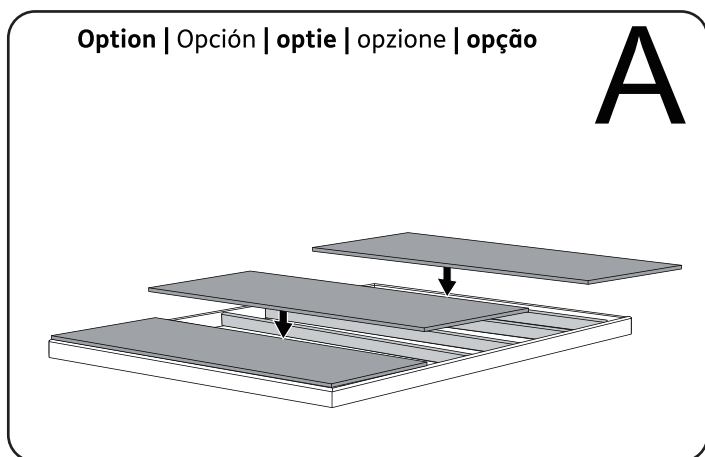

External floor measurements are: | Les mesures externes de la étage sont: | Las medidas del suelo externo son: | Die Außen-Bodenmaße betragen: | De afmetingen van de externe vloer zijn: | Le dimensioni esterne del pavimento sono: | As medidas externas do chão são:



BEFORE STARTING ASSEMBLY | AVANT DE COMMENCER LE MONTAGE | ANTES DE EMPEZAR EL ARMADO | VOR MONTAGEBEGINN | VOORDAT U BEGINT TE MONTEREN | PRIMA DI INIZIARE L'ASSEMBLAGGIO | ANTES DE INICIAR A MONTAGEM

Read the care and safety guidelines at the end of this manual | Check to ensure that there are no missing or damaged parts BEFORE starting or arranging assembly | Remove all parts from the package(s) and spread them out on a clean work surface | Review all assembly instructions | Assemble all the parts according to the directions in this manual. Do not skip any steps.

Lisez les instructions de précaution et de sécurité à la fin de ce manuel | Assurez-vous qu'il n'y a pas de pièces manquantes ou endommagées AVANT de commencer ou d'organiser l'assemblage | Retirez toutes les pièces du/des paquet(s) et étalez-les sur une surface de travail propre | Lisez toutes les instructions de montage | Assemblez toutes les pièces selon les instructions de ce manuel. Ne sautez aucune étape.

Lea las instrucciones de precauciones y seguridad que están al final de este manual | Asegúrese de que no faltan piezas ni están dañadas ANTES de comenzar o disponer el montaje | Saque todas las piezas del paquete o paquetes y póngalas sobre una superficie de trabajo limpia | Revise todas las instrucciones de montaje | Monte todas las piezas según las instrucciones de este manual. No se saltee ningún paso.

Lesen Sie die Sicherheitsrichtlinien am Ende des Benutzerhandbuchs durch | Prüfen Sie bitte VOR dem Zusammenbau, dass keine Teile beschädigt sind oder fehlen | Nehmen Sie alle Teile aus der Verpackung und breiten Sie sie auf einer sauberen Arbeitsfläche aus | Gehen Sie noch einmal die komplette Aufbauanleitung durch | Bauen Sie alle Teile entsprechend der Anleitung in diesem Handbuch zusammen. Lassen Sie dabei keinen Arbeitsschritt aus.

Lees de richtlijnen voor zorg en veiligheid achterin deze handleiding | Controleer dat er geen onderdelen mankeren, of beschadigd zijn, VOORDAT u met de montage begint | Haal alle onderdelen uit het pakket (of uit de pakketten) en leg ze opeen schoon werkoppervlak | Bekijk alle montagehandleidingen | Monteer alle onderdelen volgens de aanwijzingen van deze handleiding. Sla geen stappen over.

Leggere le linee guida di assistenza e sicurezza alla fine di questo manuale | Assicurarsi che non ci siano parti mancanti o danneggiate PRIMA di iniziare l'assemblaggio | Estrarre tutti i componenti dall'imbollo e posizionarli su una superficie di lavoro pulita | Consultare tutte le istruzioni di montaggio | Assemblare tutti i componenti secondo le istruzioni contenute nel manuale. Non saltare nessuna fase.

Leia as diretrizes de cuidados e segurança que constam da parte final deste manual | Verifique para se assegurar de que não há peças em falta ou danificadas ANTES de começar a preparar a montagem | Retire todas as peças da embalagem e espalhe-as numa superfície de trabalho limpa | Reveja todas as instruções de montagem | Monte todas as peças de acordo com as instruções do manual. Não salte quaisquer passos.

REQUIRED TOOLS | OUTILS EXIGÉS | HERRAMIENTAS NECESARIAS | BENÖTIGTE WERKZEUGE | BENODIGD GEREEDSCHAP | ATTREZZATURA OCCORRENTE | FERRAMENTAS NECESSÁRIAS

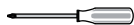

SPATULA | SPATULE | ESPÁTULA | SPACHTEL | SPATEL | SPATOLA | ESPÁTULA

- Use spatula (part “SG8”) for easier insertion of panel into profile.
- Utilisez la spatule (partie “SG8”) pour une meilleure insertion du panneau dans le profil.
- Utilice una espátula (pieza “SG8”) para una mejor inserción del panel en el perfil.
- Benutzen Sie den Spachtel (Bezeichnung “SG8”), um die Platten leichter in die Nut einführen zu können.
- Gebruik spatel (onderdeel SG8) voor het gemakkelijk invoeren van het paneel in het profiel.
- Utilizzare la spatola (parte SG8) per inserire il pannello più facilmente nel profilo.
- Utilize uma espátula (peça “SG8”) para facilitar a inserção do painel no perfil.

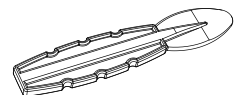

SG8x2



ASSEMBLY REQUIRES TWO PEOPLE | LE MONTAGE DOIT ÊTRE EFFECTUÉ PAR DEUX PERSONNES | SE NECESITAN DOS PERSONAS PARA ARMARLO | ZWEI PERSONEN ZUR MONTAGE NOTWENDIG | MONTAGE VEREIST TWEE PERSONEN | L'ASSEMBLAGGIO RICHIEDE DUE PERSONE | A MONTAGEM EXIGE DUAS PESSOAS

Parts

CW4-3 x1



CW4-1 x1

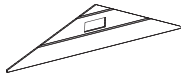

CW3L x1

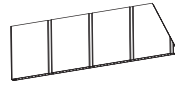

CR1-2 x1



CW2-2 x2

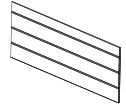

CF1-2 x1

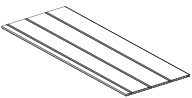

CW3R x1

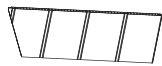

CR1-1 x2

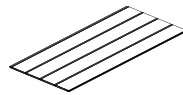

CR1-3 x1

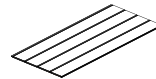

CW1-2 x1

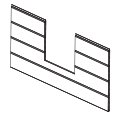

CW1-1 x3

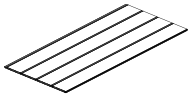

CW2-1 x4

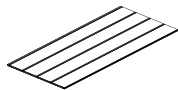

CF1-1 x2

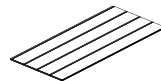

CW3-1 x4



CW1-3 x1

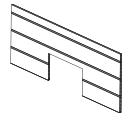

CW1-4 x1

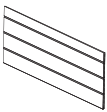

CD1-1 x1

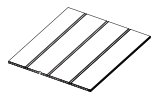

CD1-2 x1

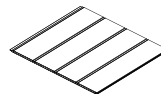

CD1-3 x1

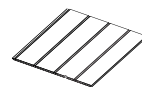

CD1-4 x1

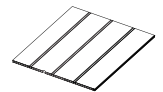

CD1-5 x1

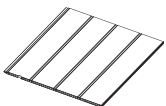

CD1-6 x1



SG10 x1



SG101 x1

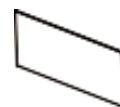

SG102 x1

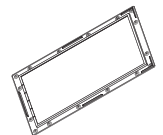

Parts

CA4 x2

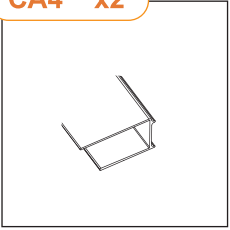

CS1 x2

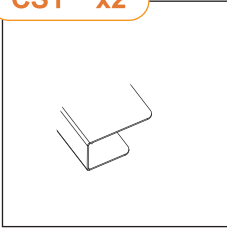

CP1 x1

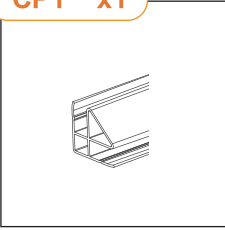

CP2 x2

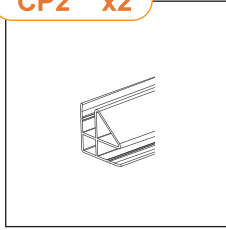

CP3 x2

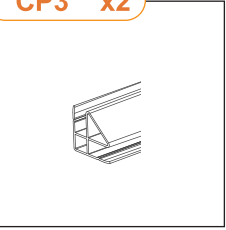

CP5 x4

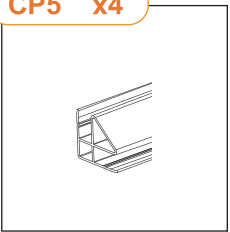

CP4 x1

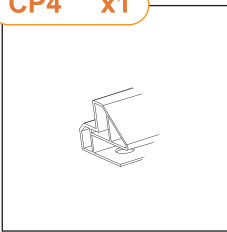

CP6 x2

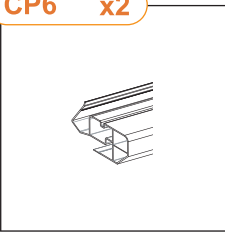

CP7 x4

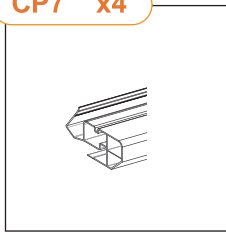

CA1R x1

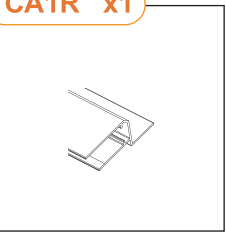

CA1L x1

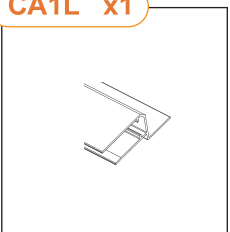

CA3 x1

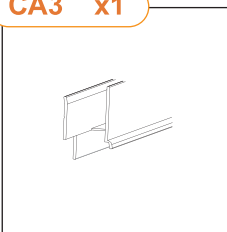

CA2 x1

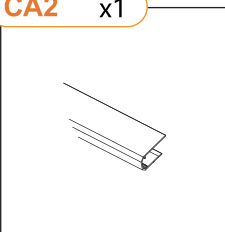

CA2R x1

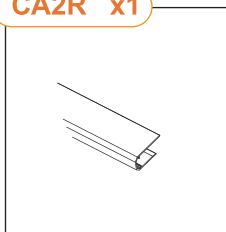

CA2L x1

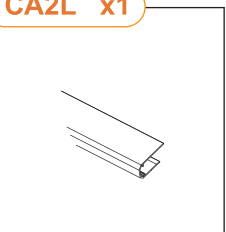

CPA1 x1

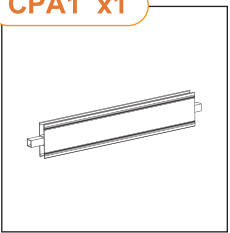

CPA2 x1

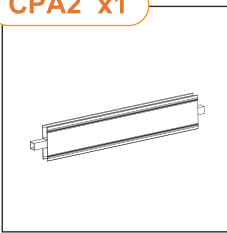

CA1 x1

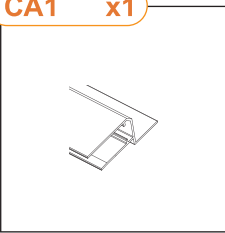

SG2 x4

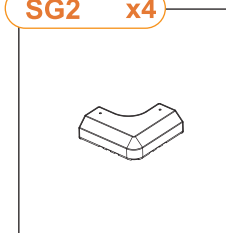

SG7-2 x1

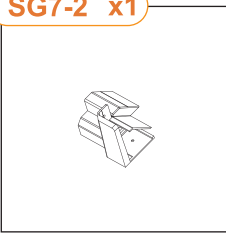

SG7-1 x1

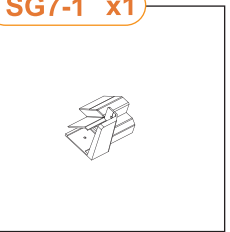

SG8 x2

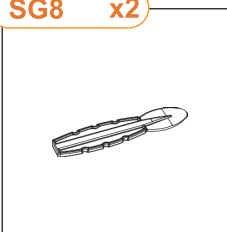

SG9 x5



SG1 x2

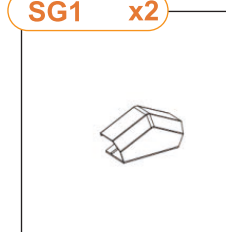

BY x2

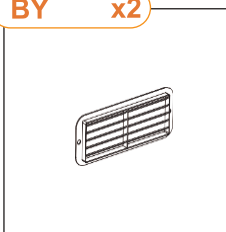

SG14 x4

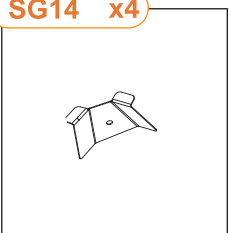

SG13 x2

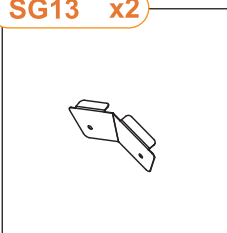

SG6 x4



SG12 x2

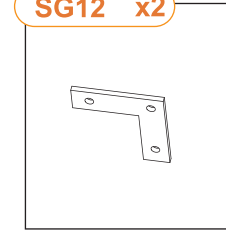

Parts

LOCK x1

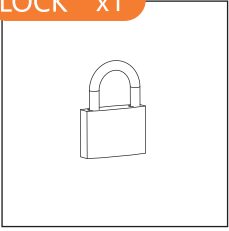

Drill x1



DC x2

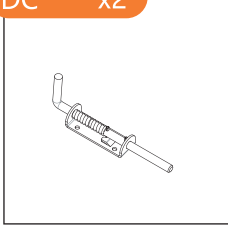

MO1 x4

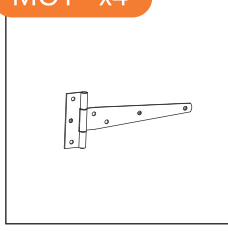

M03-6L x1

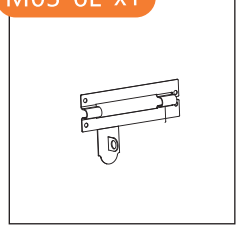

M03-7 x1

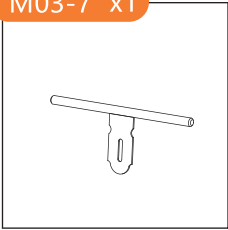

MO4 x1

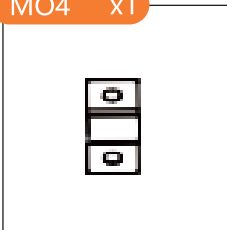

Z410 x84+4



Z420 x105+5

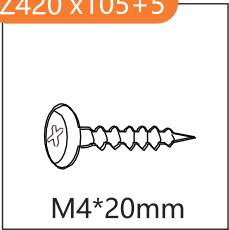

Z425 x4+1

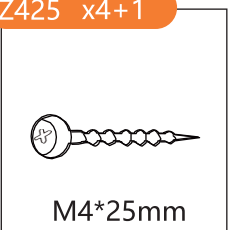

ZW413 x22+2



PARTS SCHEMATIC

ROOF PARTS

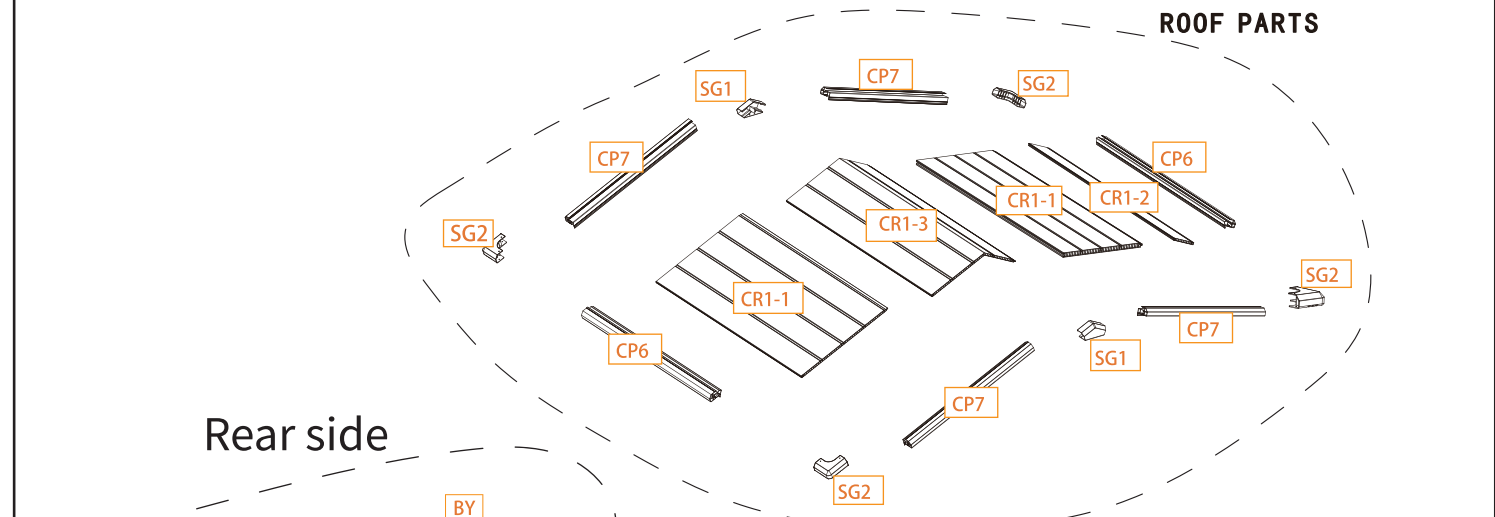

Rear side

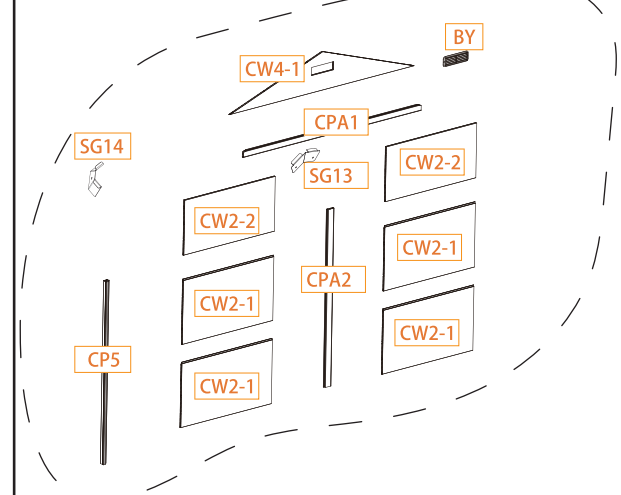

Right

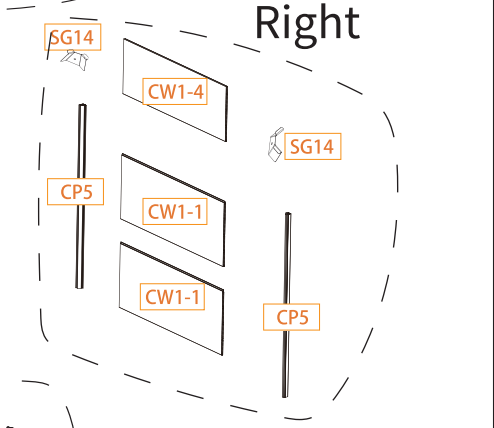

Front

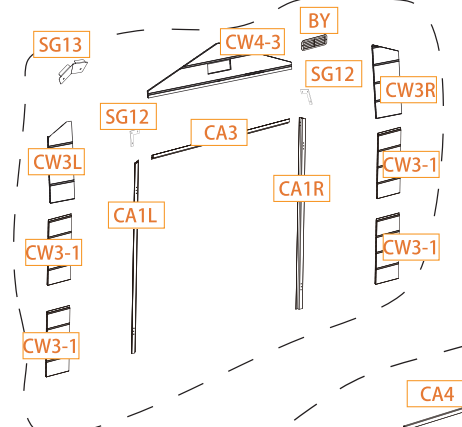

Left

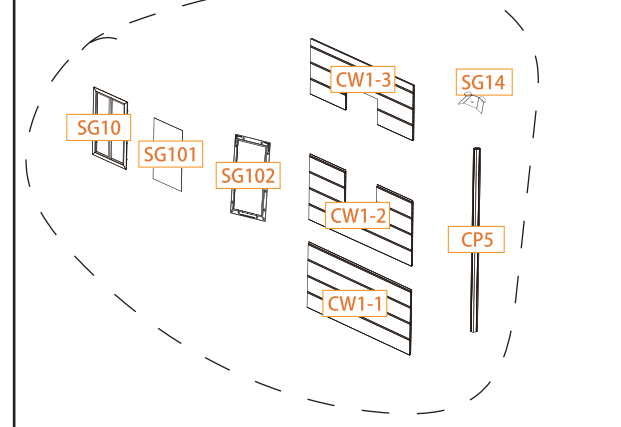

DOOR PARTS

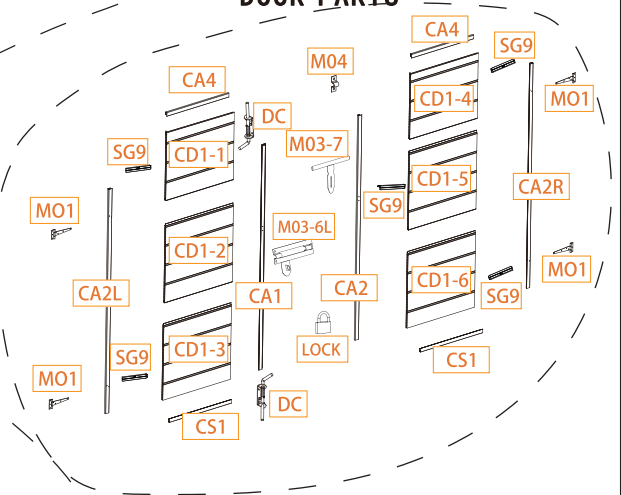

FLOOR PARTS

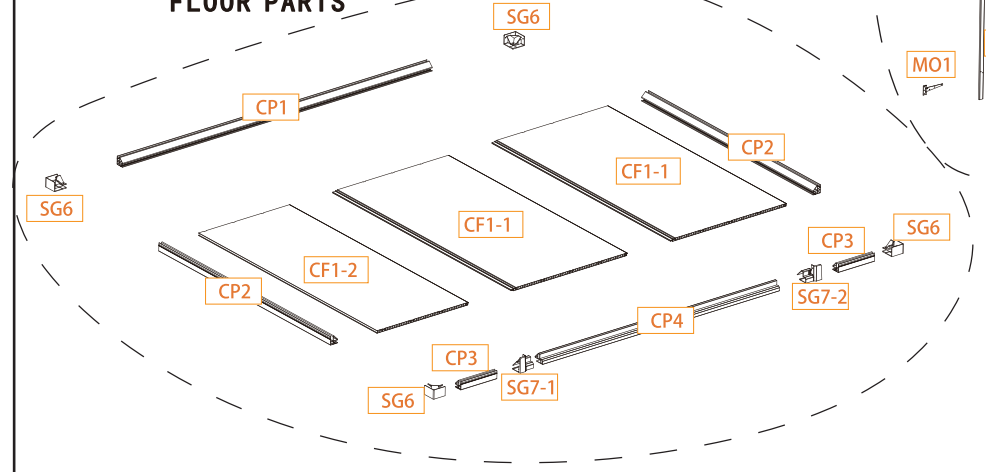

FLOOR ASSEMBLY



● Use spatula (part "SG8") for easier insertion of panel into profile



Note: The crease line of the floor must be underneath

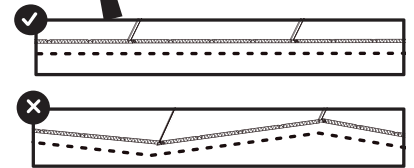
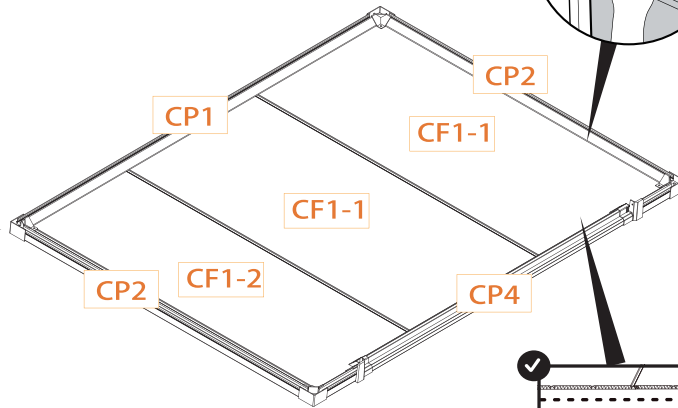
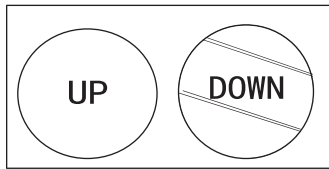

Step 1

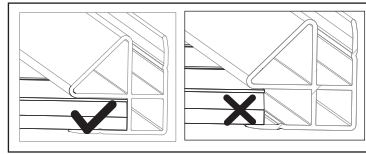

● Fully fit the panel inside the profile

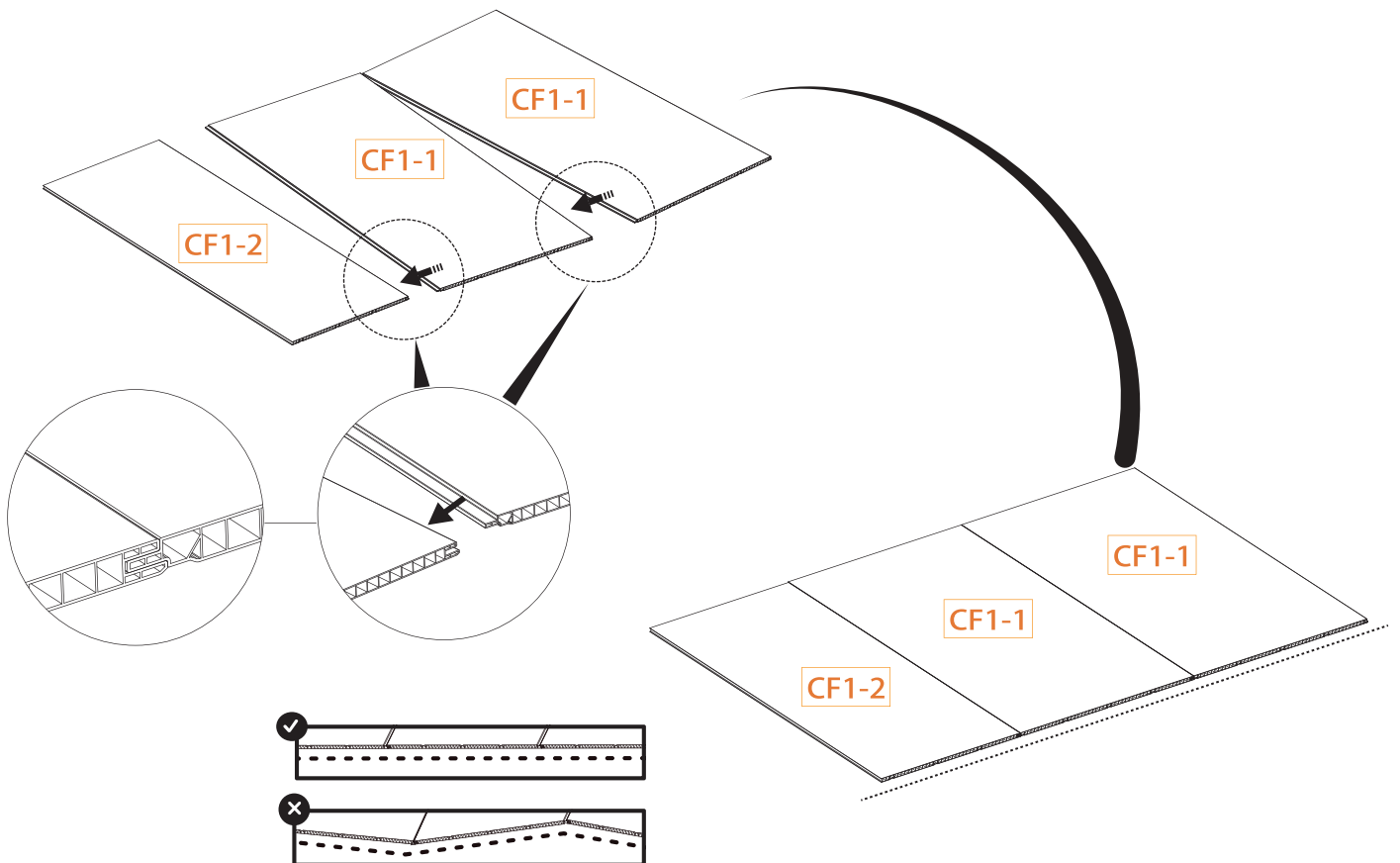
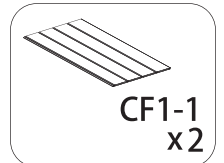
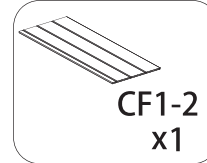

Step 2

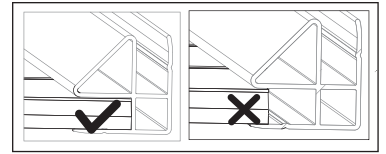
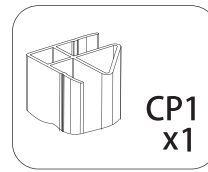
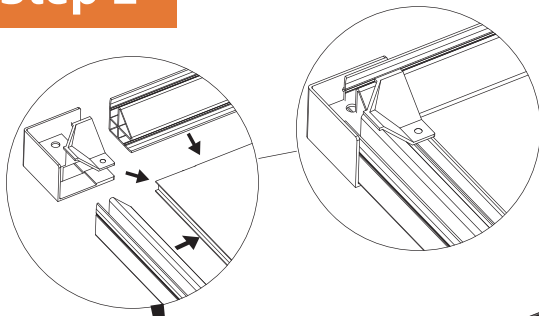

● Fully fit the panel inside the profile

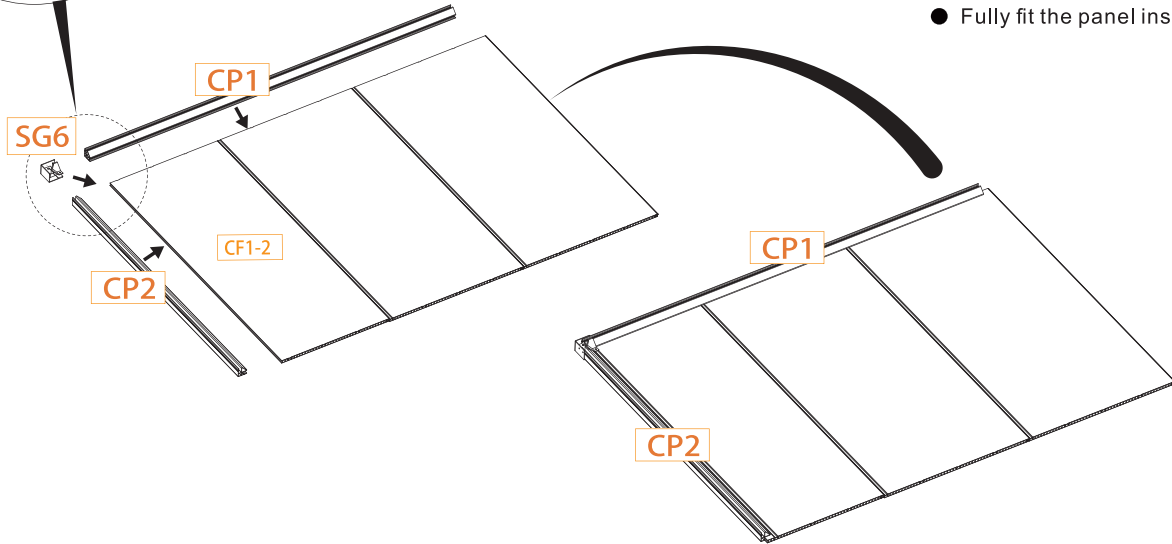

Step 3

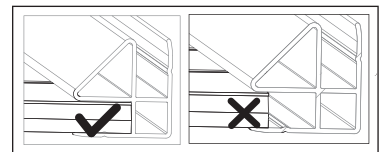
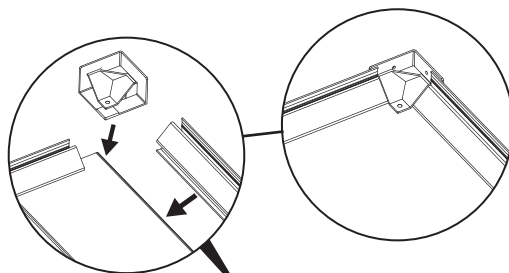

● Fully fit the panel inside the profile

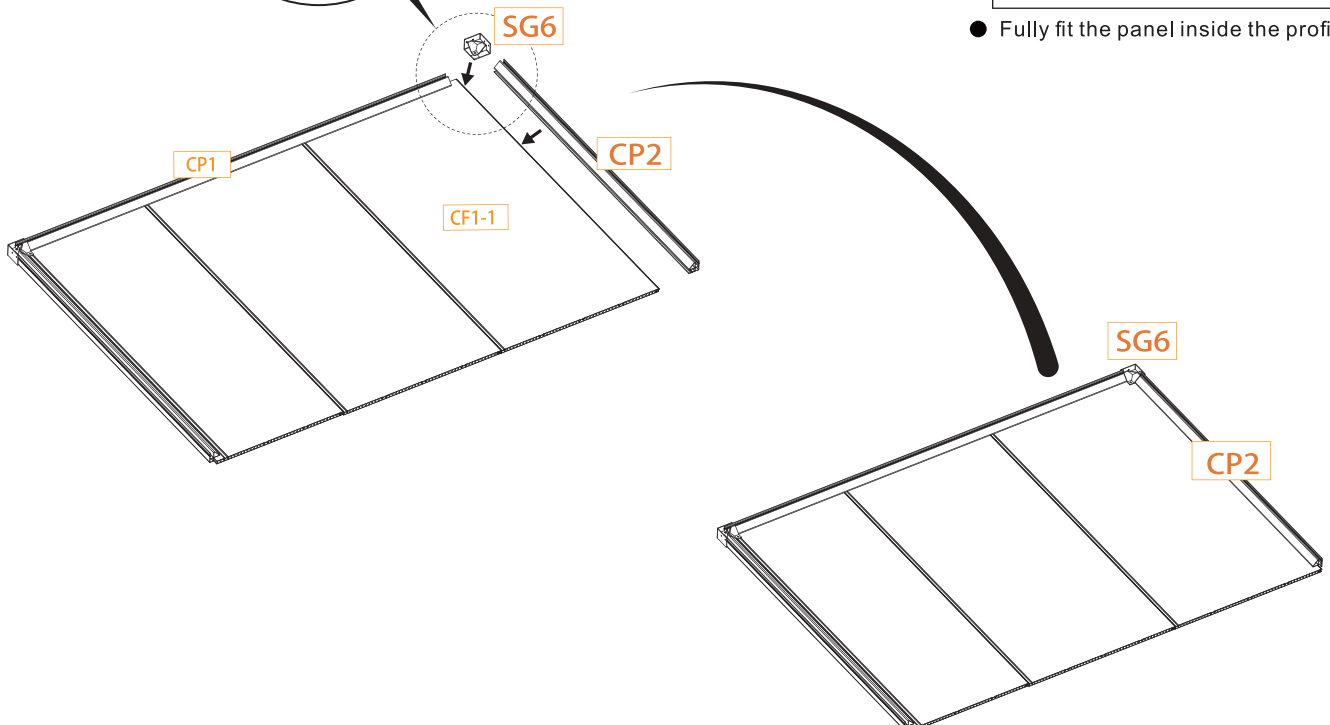

Step 4

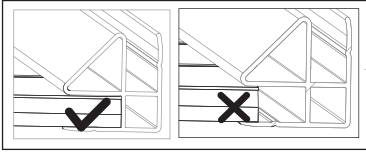
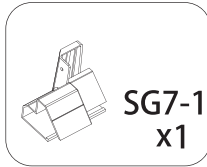
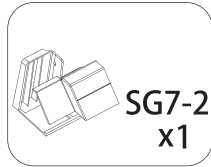

- Fully fit the panel inside the profile

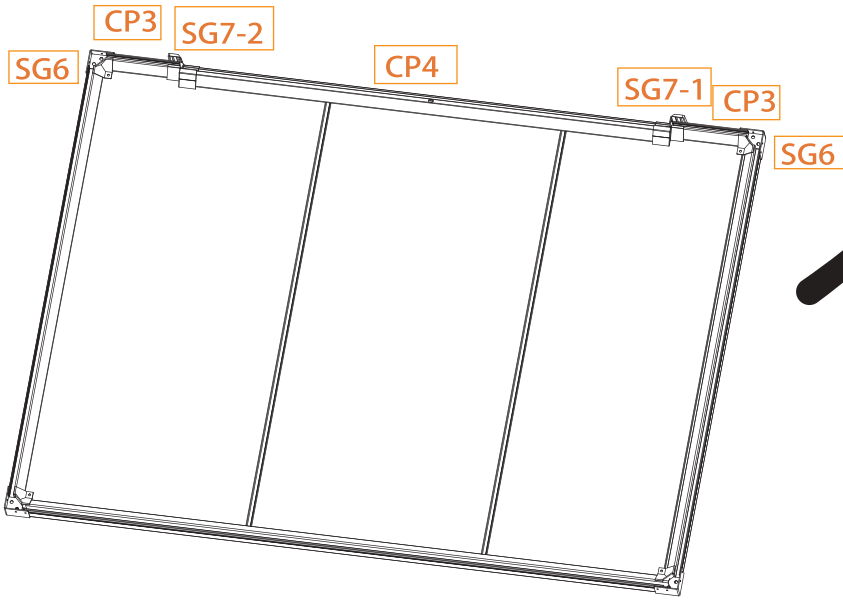
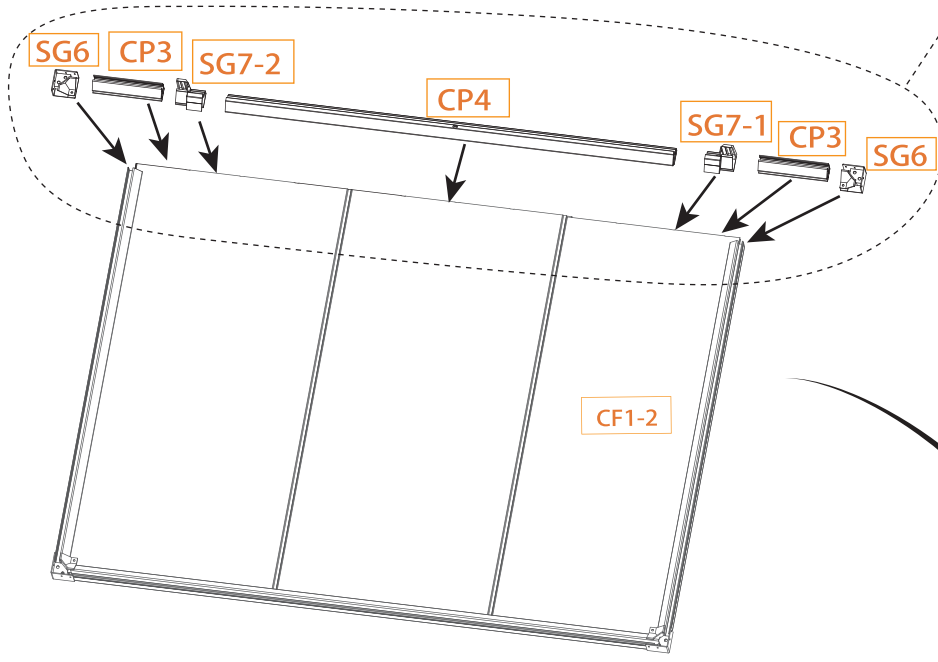
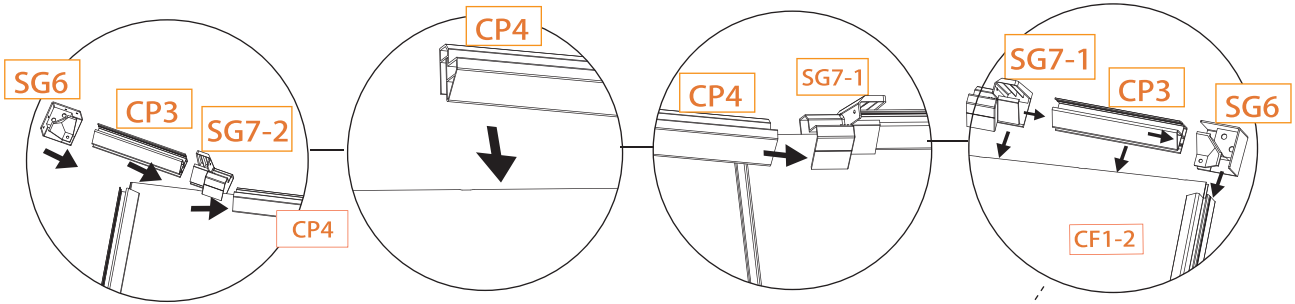

Step 5

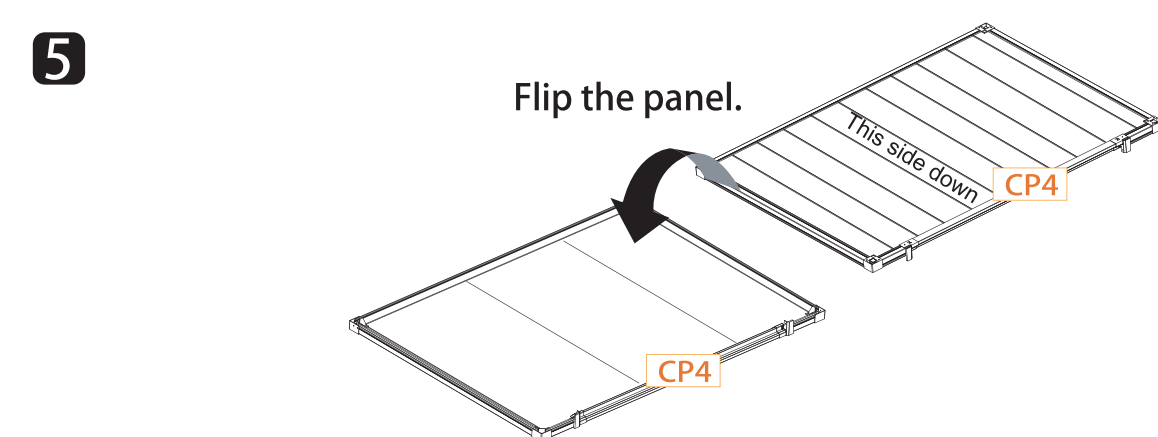
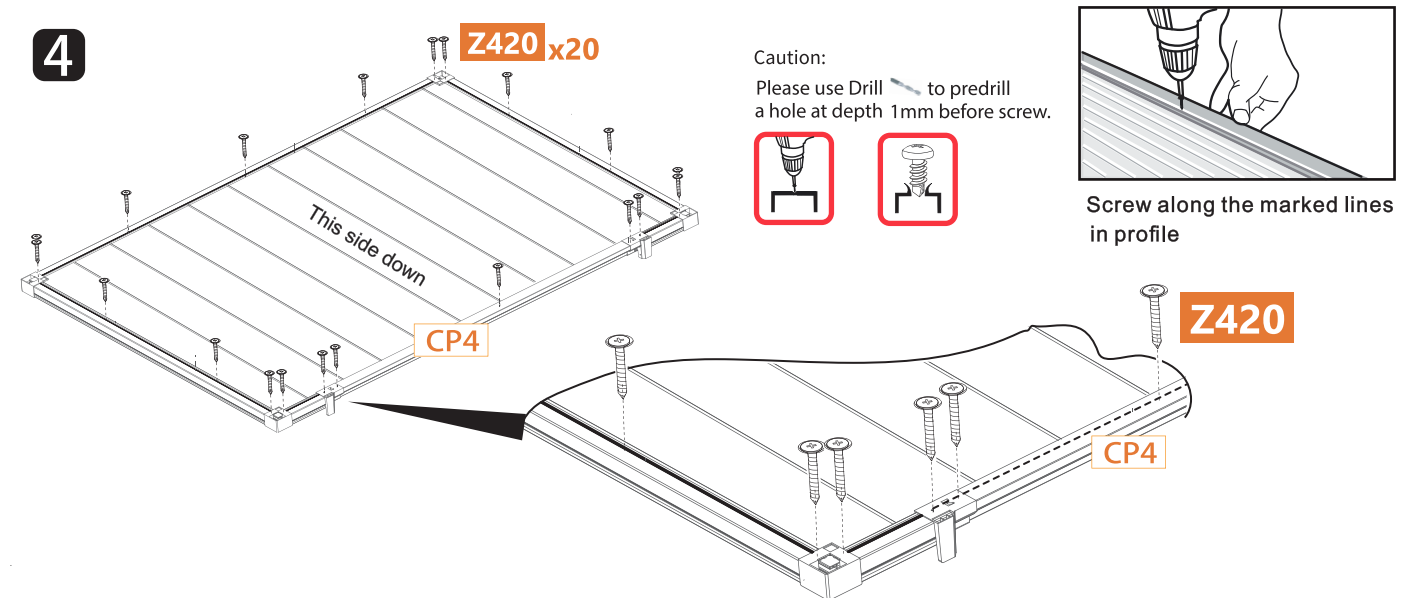
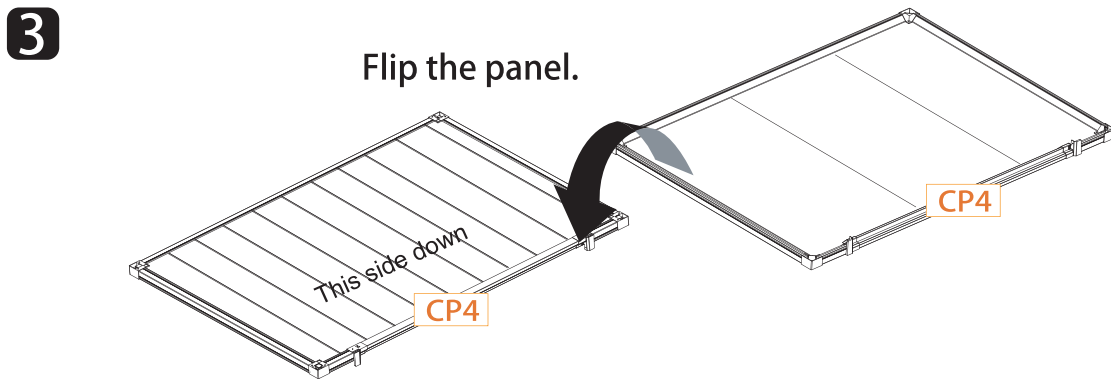
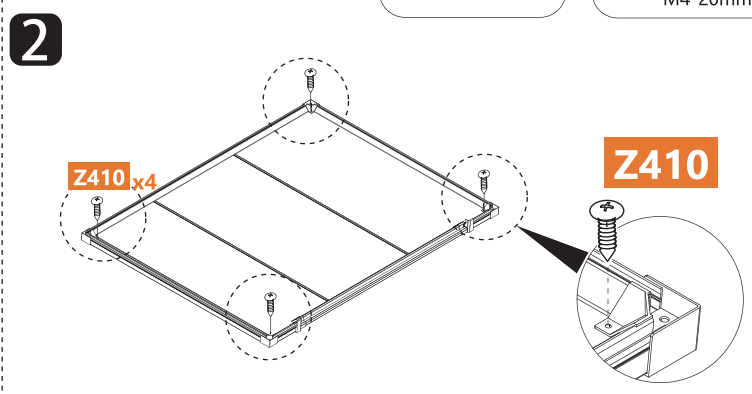
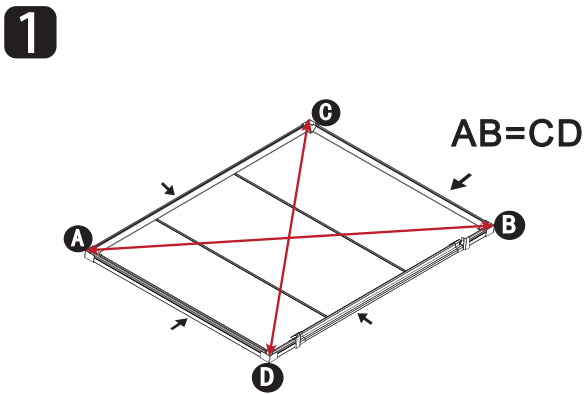

WALL ASSEMBLY

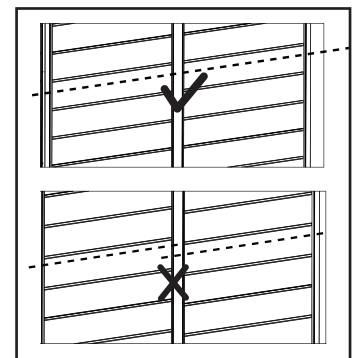
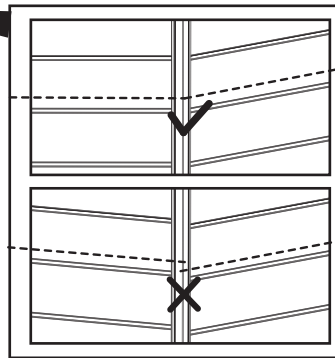
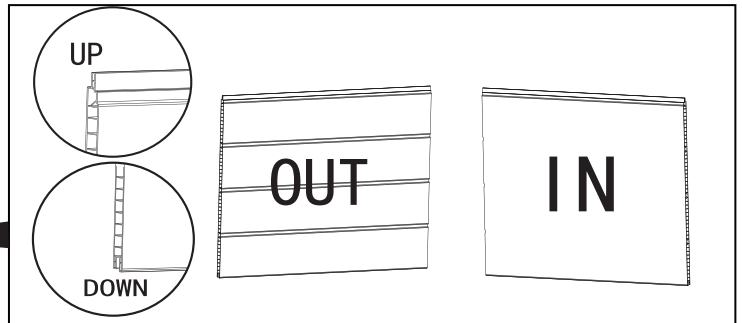
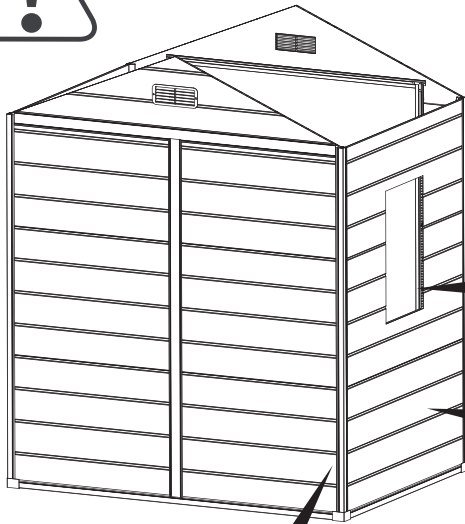

Step 6

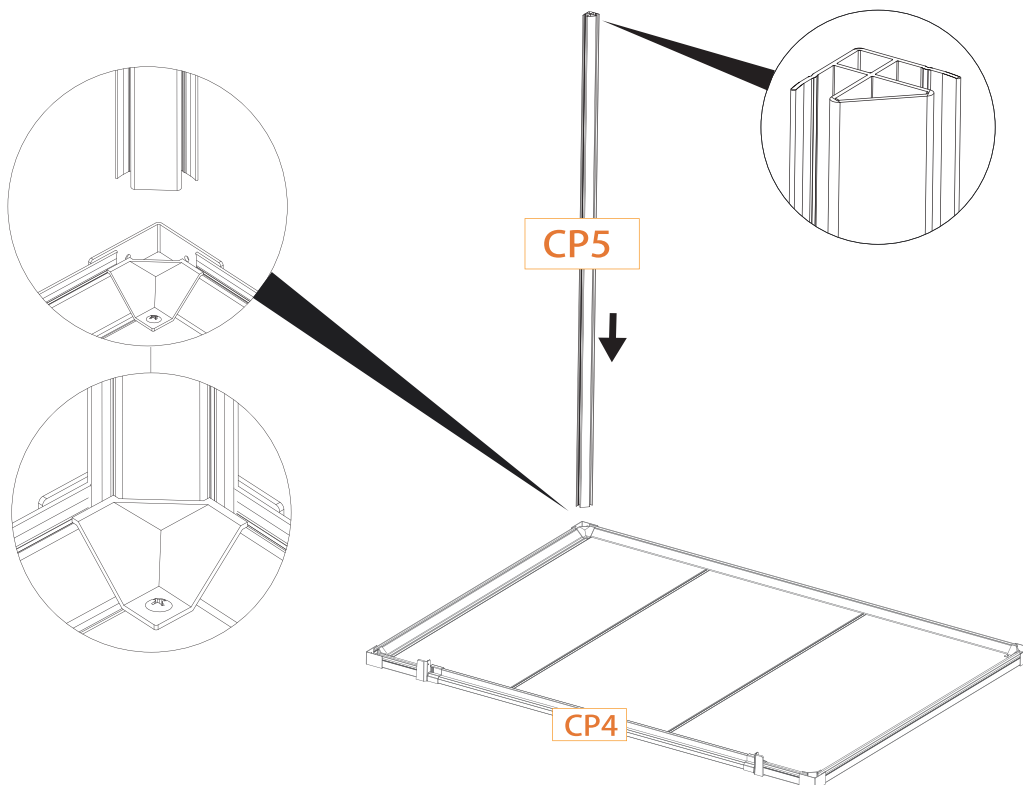
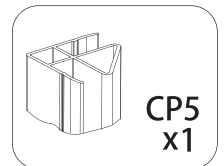

Step 7

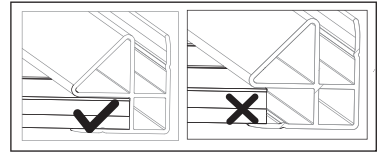
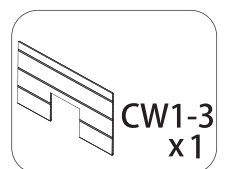
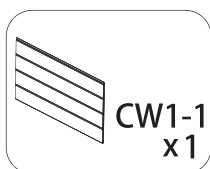
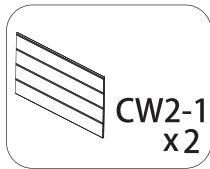
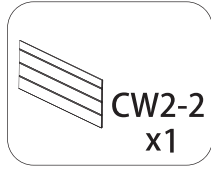

● Fully fit the panel inside the profile

1

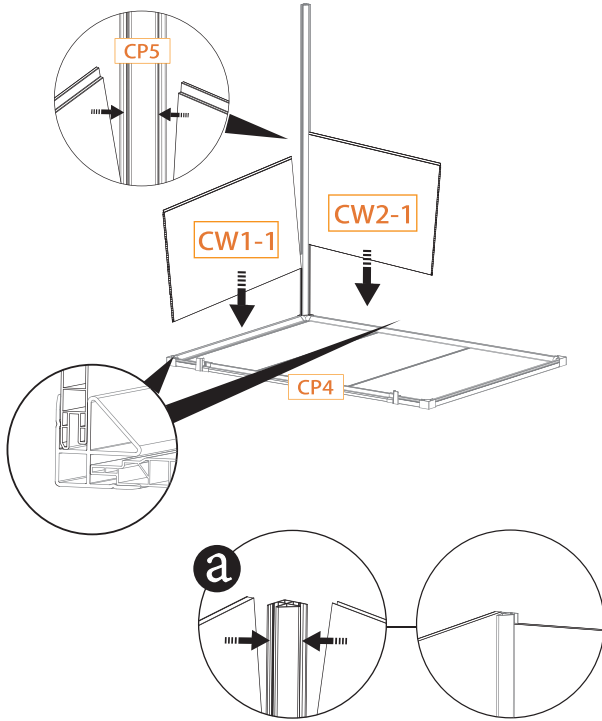

2

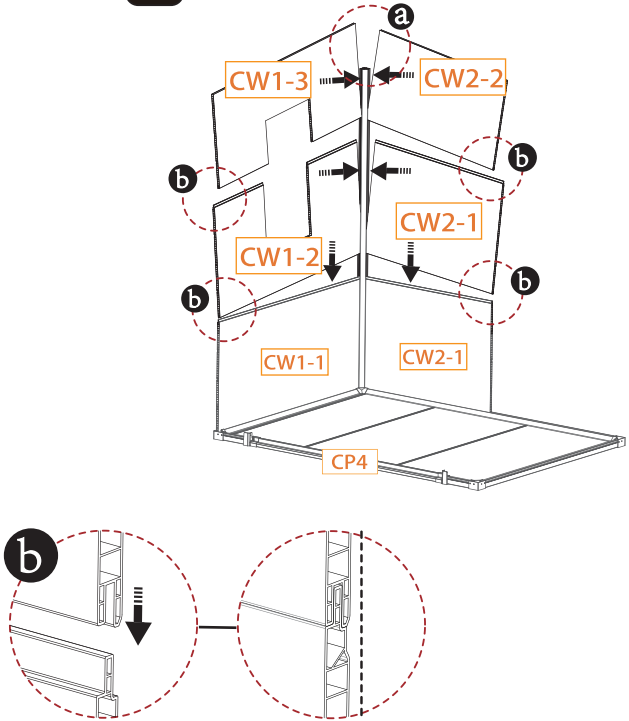

Step 8

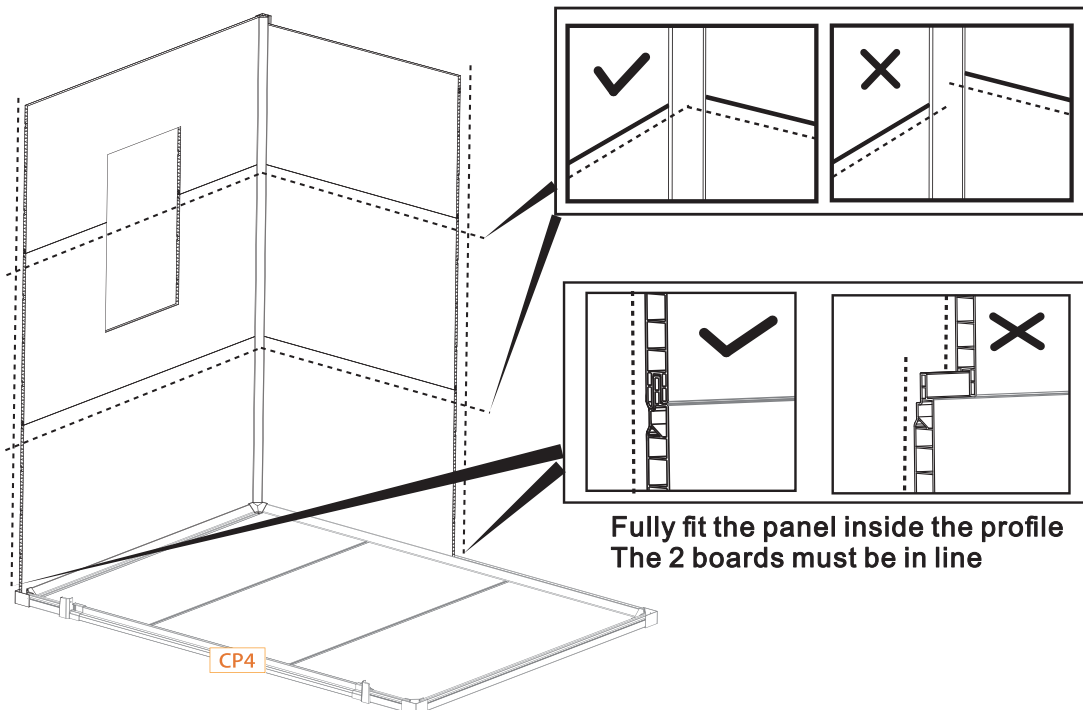

Fully fit the panel inside the profile
The 2 boards must be in line

Step 9

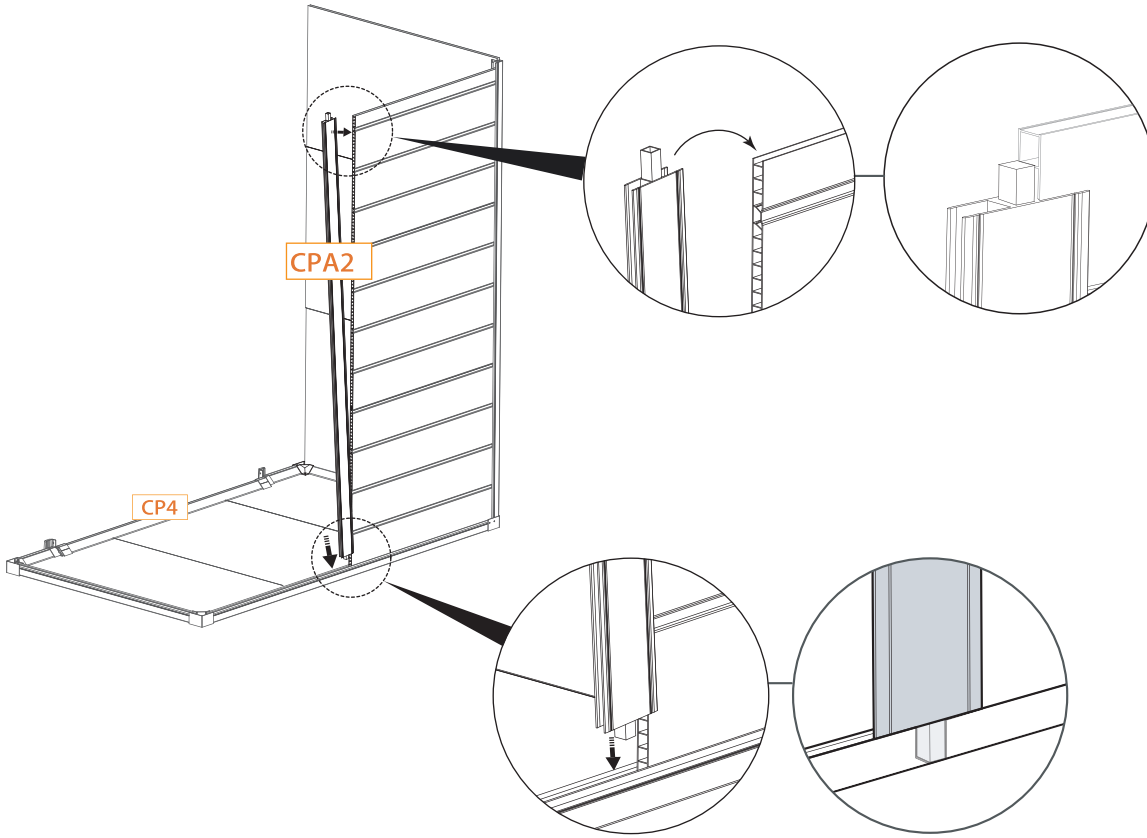
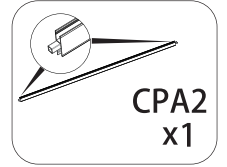

Step 10

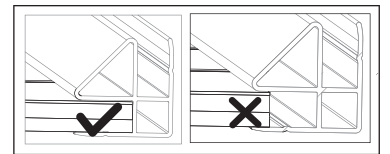
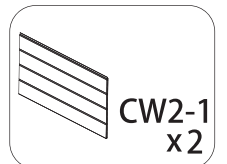
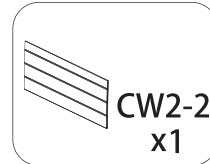
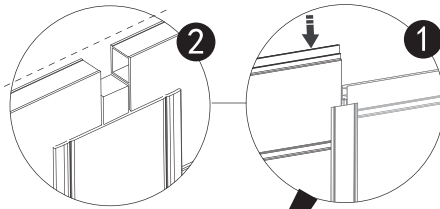

- Fully fit the panel inside the profile

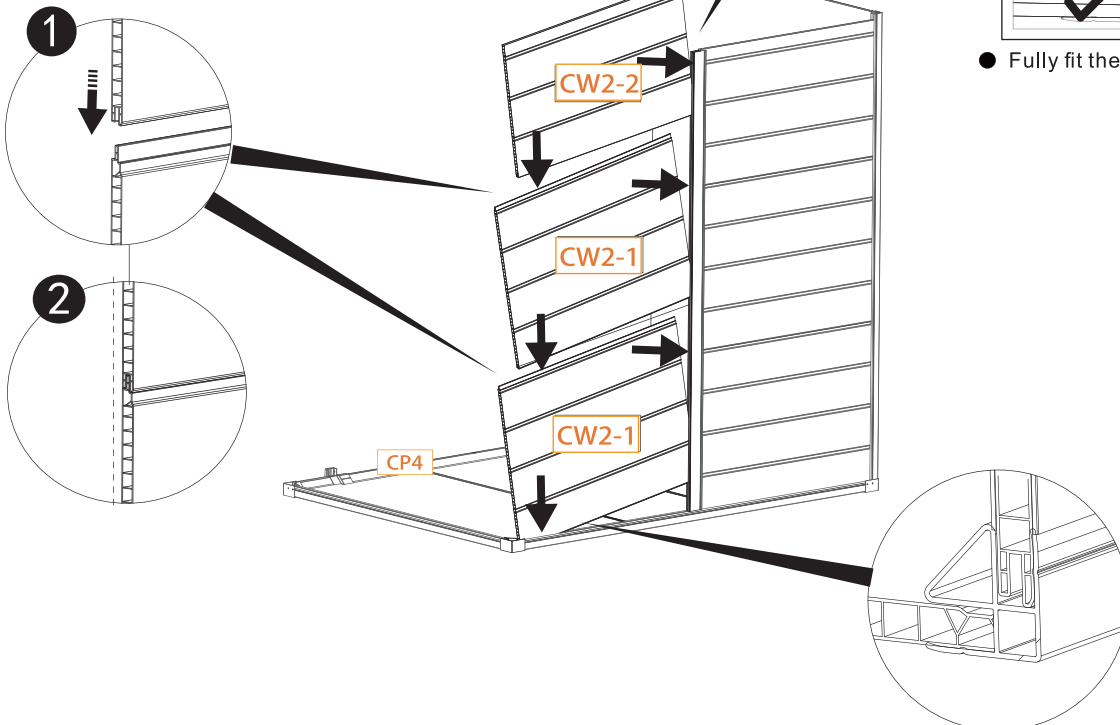

Step 11

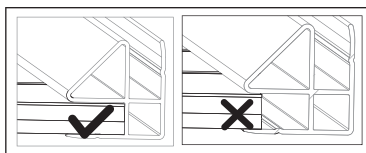

- Fully fit the panel inside the profile

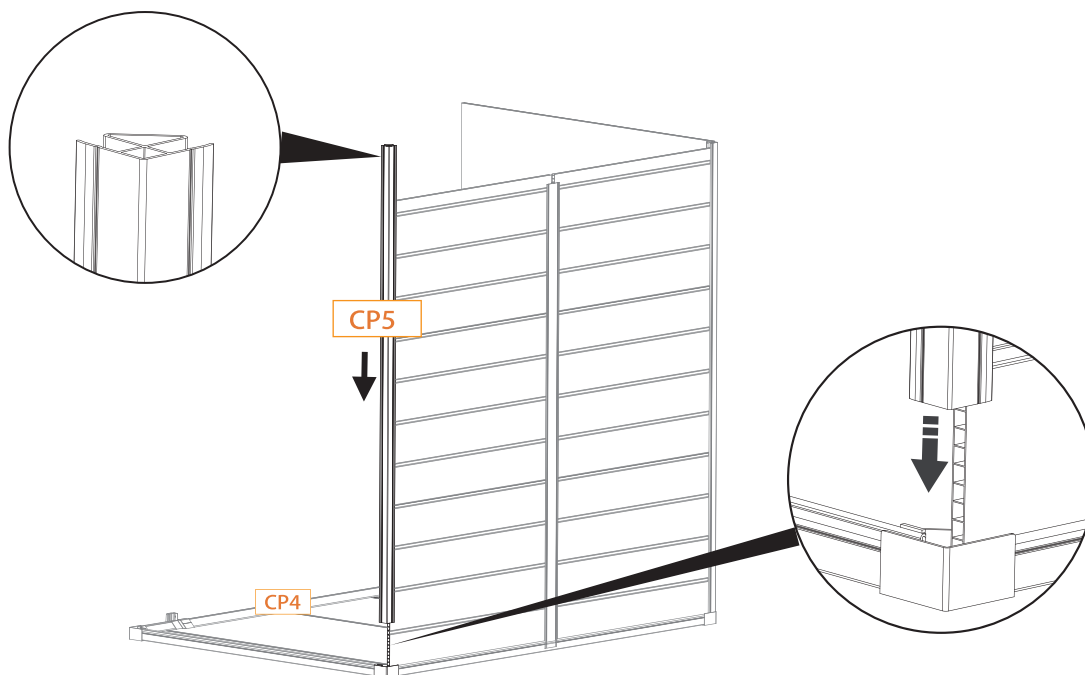

Step 12

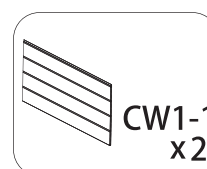
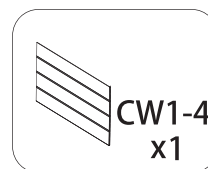
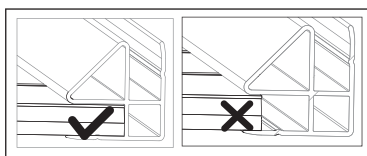

- Fully fit the panel inside the profile

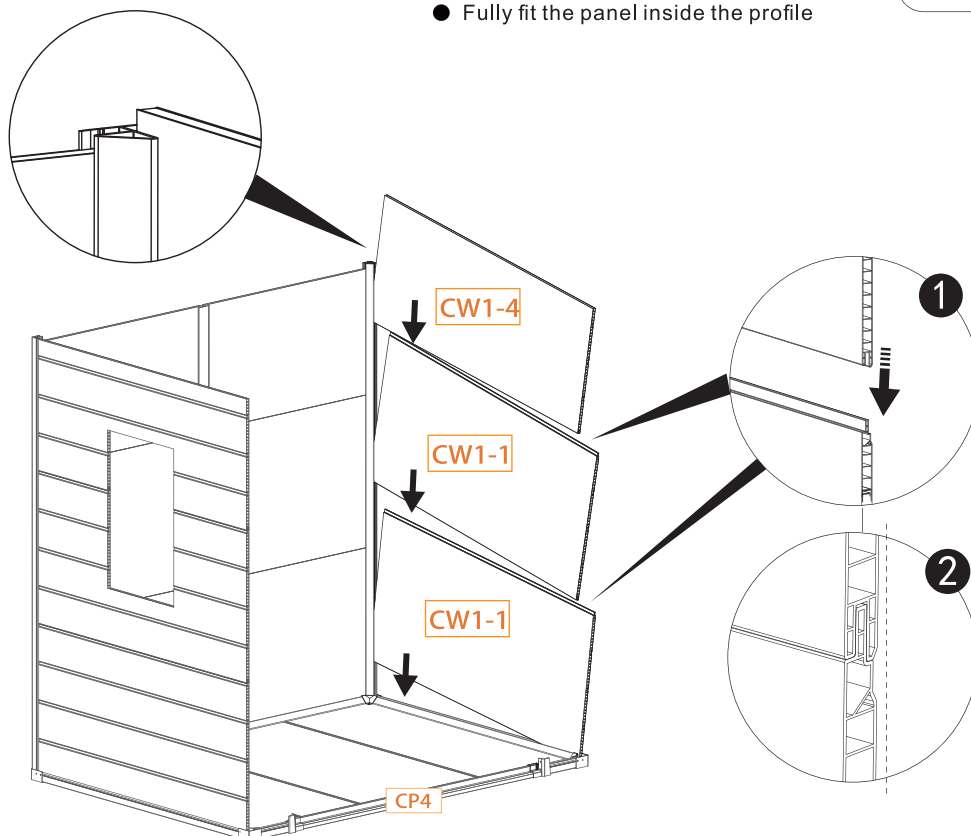

Step 13

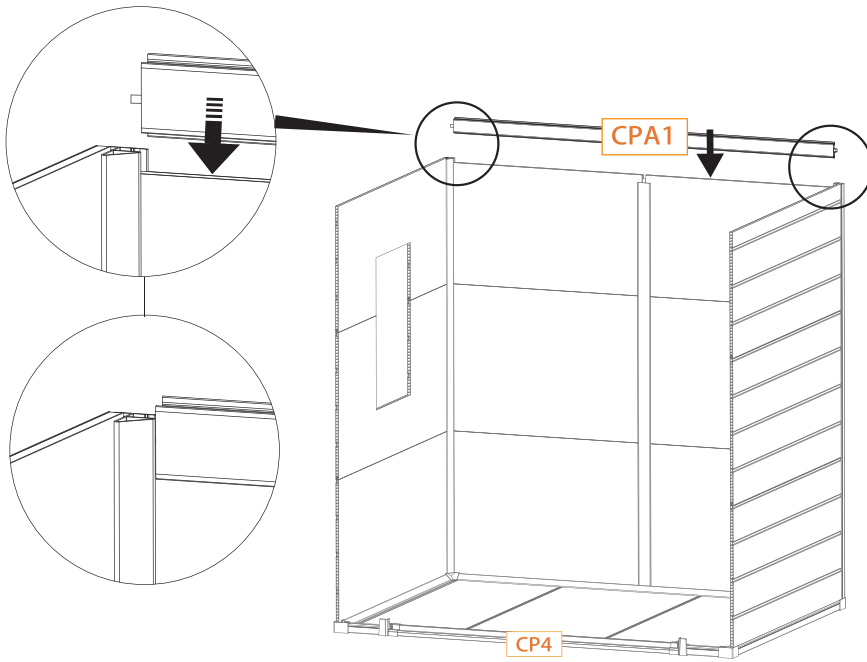
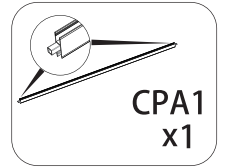

Step 14

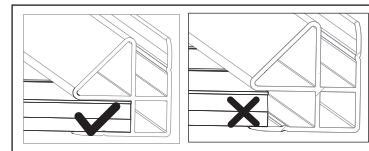

● Fully fit the panel inside the profile

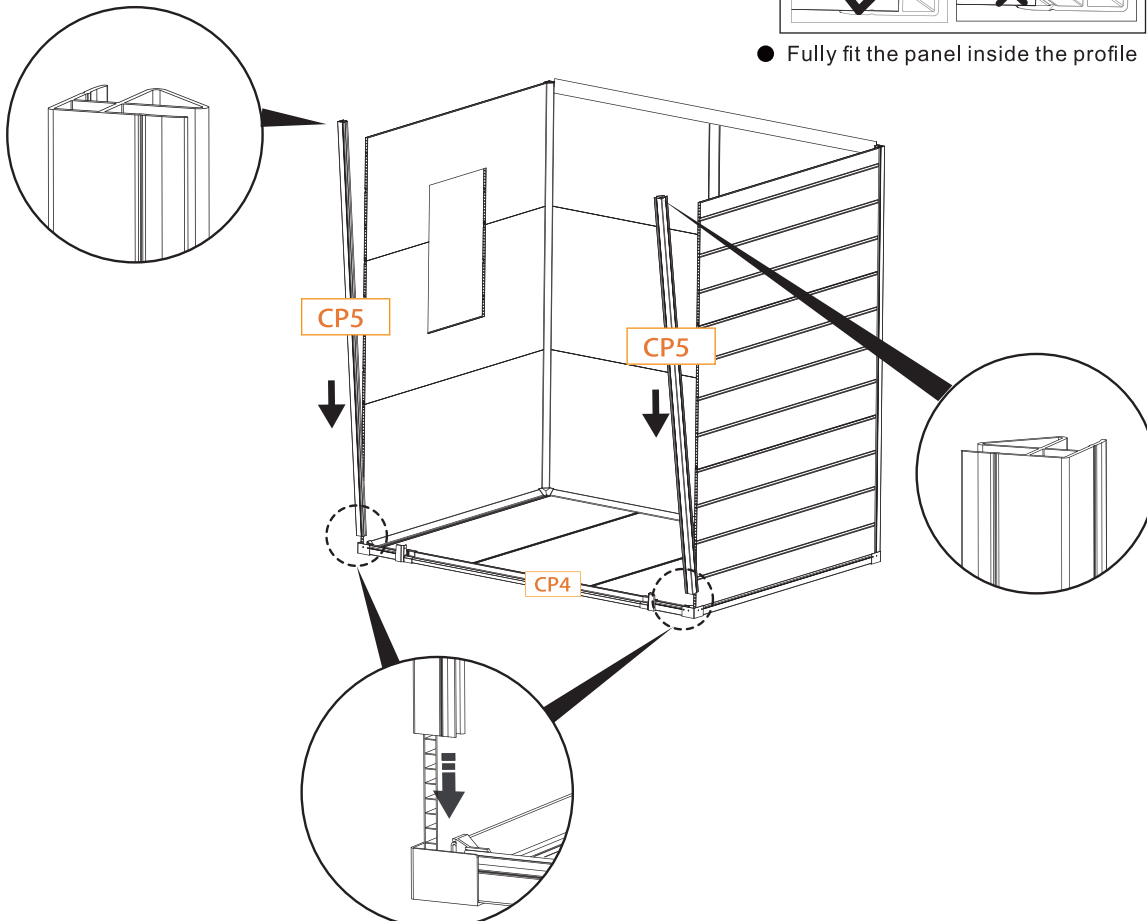

Step 15

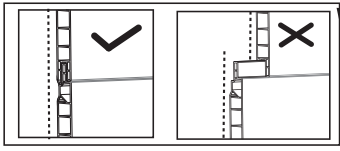
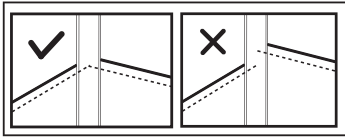

Fully fit the panel inside the profile
The 2 boards must be in line

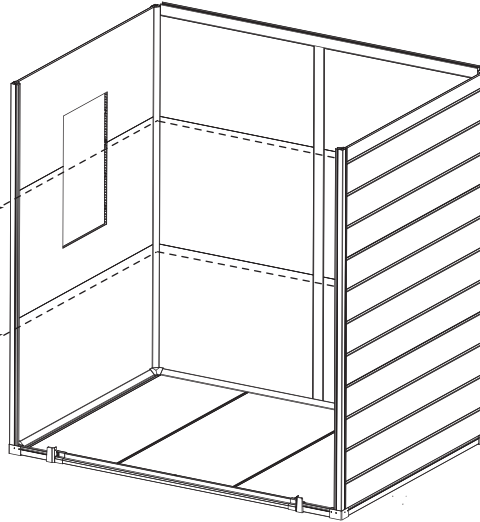

● AB=CD

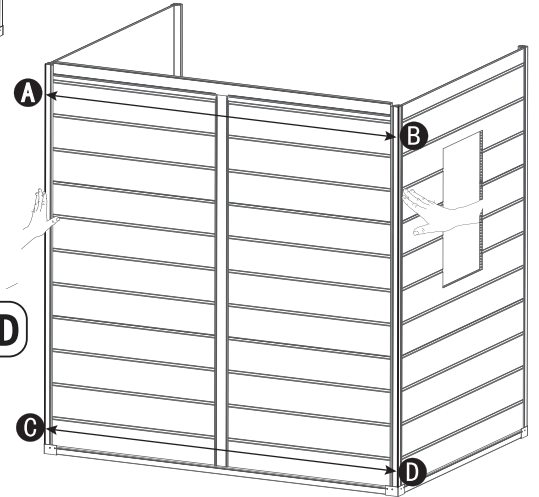

Step 16

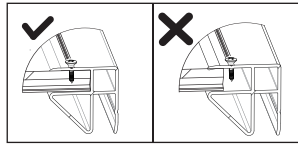

Screw along the marked lines in profile

Caution:
Please use Drill to predrill
a hole at depth 1mm before screw.

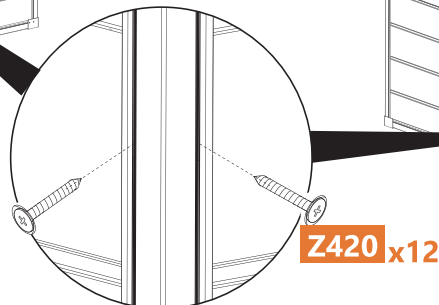
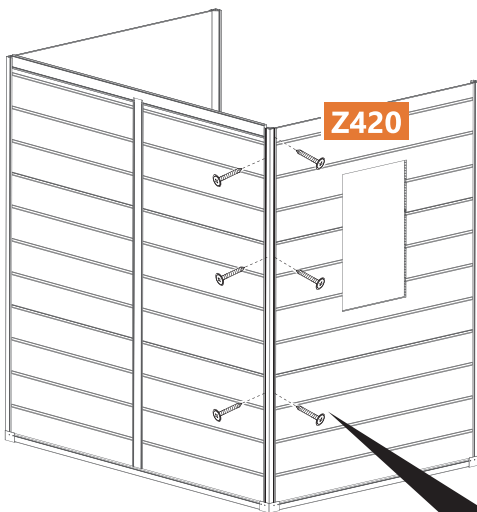
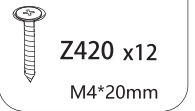

Step 17

Attention to the location of the screws: they need to be locked on the iron pipe that corresponds to the inside of the plastic profile.

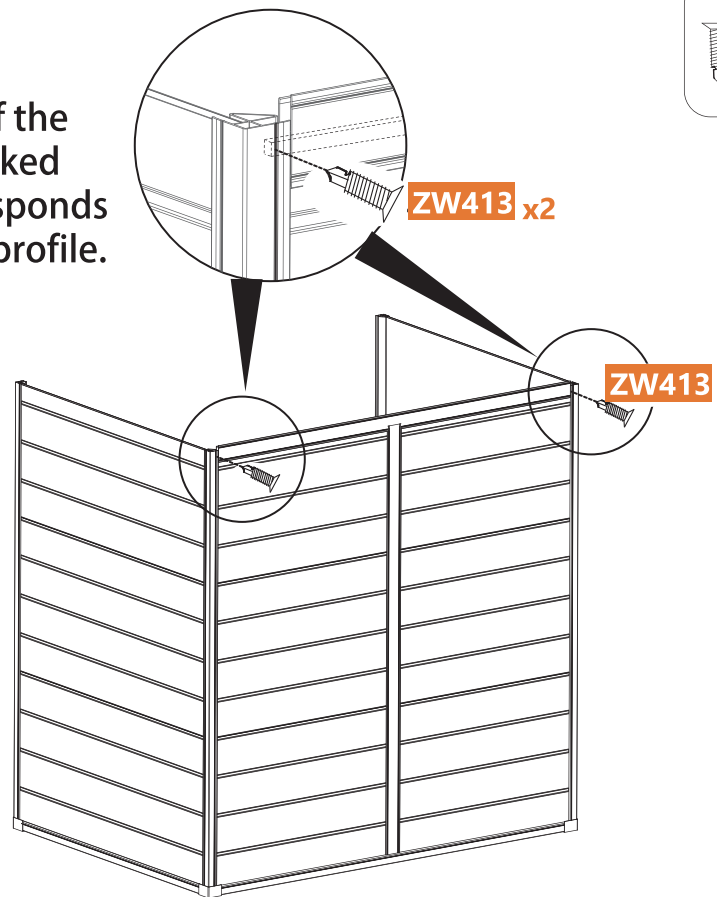

Step 18

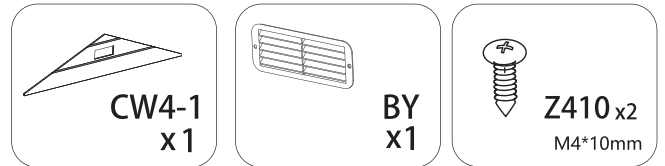

1

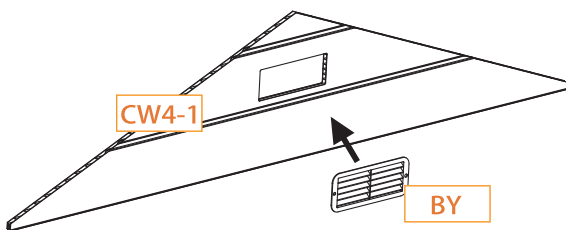

2

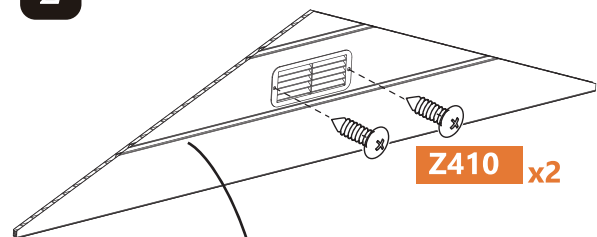

3

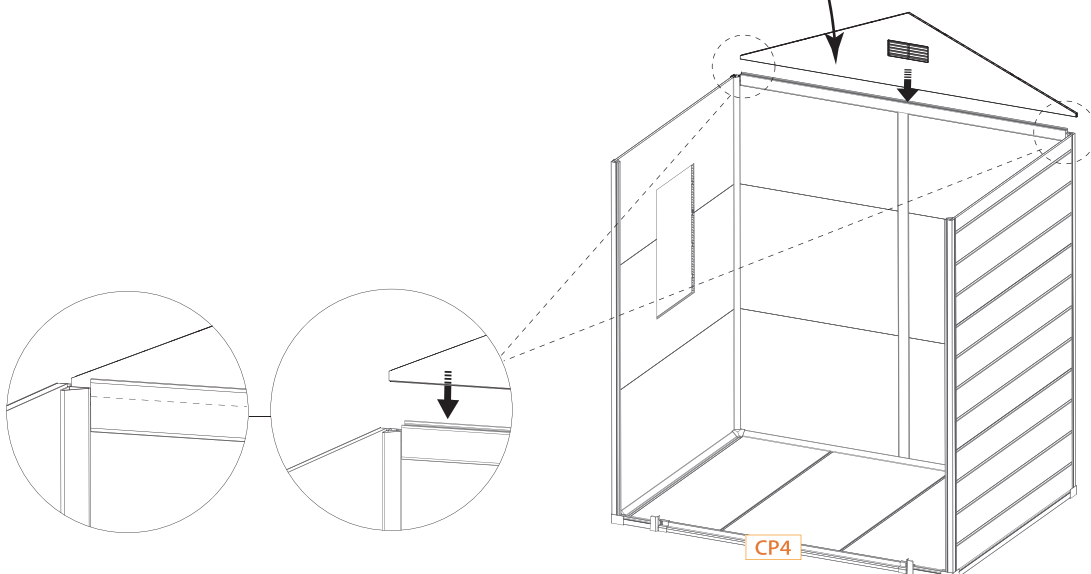

Step 19

Screw along the marked lines in profiles

Caution:
Please use Drill to predrill
a hole at depth 1mm before screw.

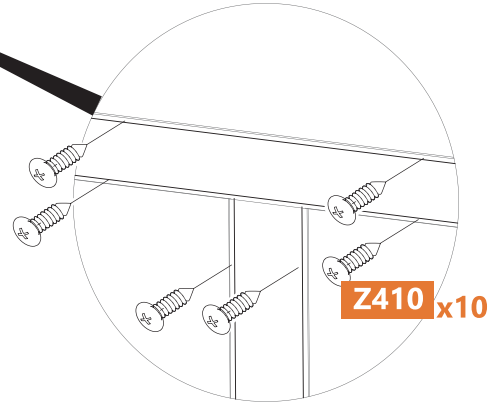
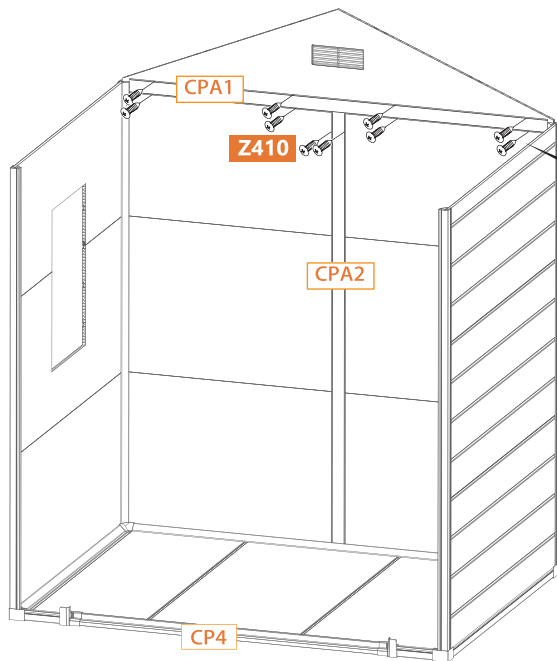
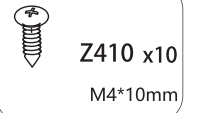

Step 20

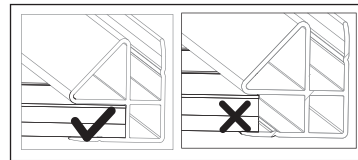

● Fully fit the panel inside the profile

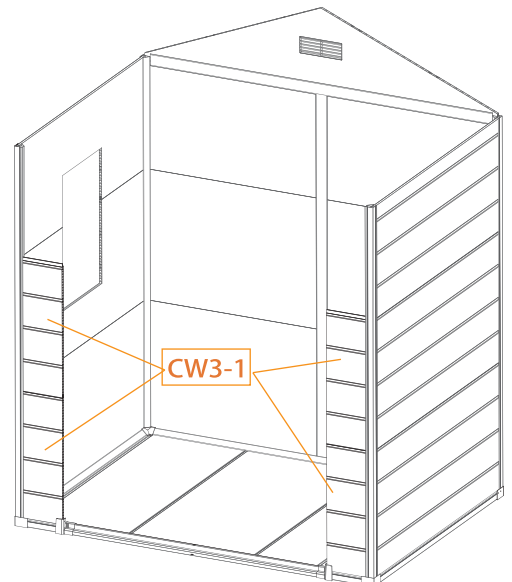
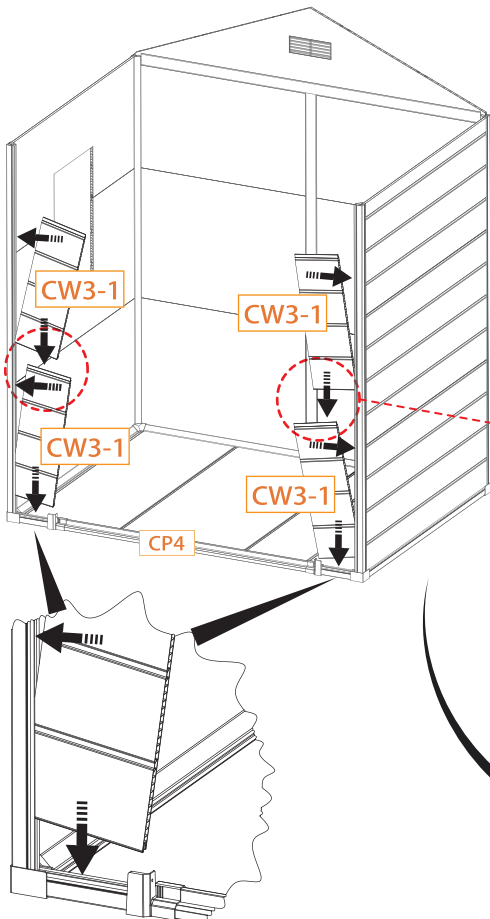
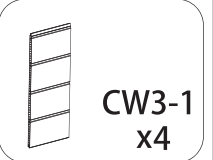

Step 21

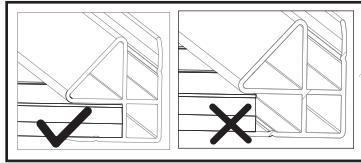

- Fully fit the panel inside the profile

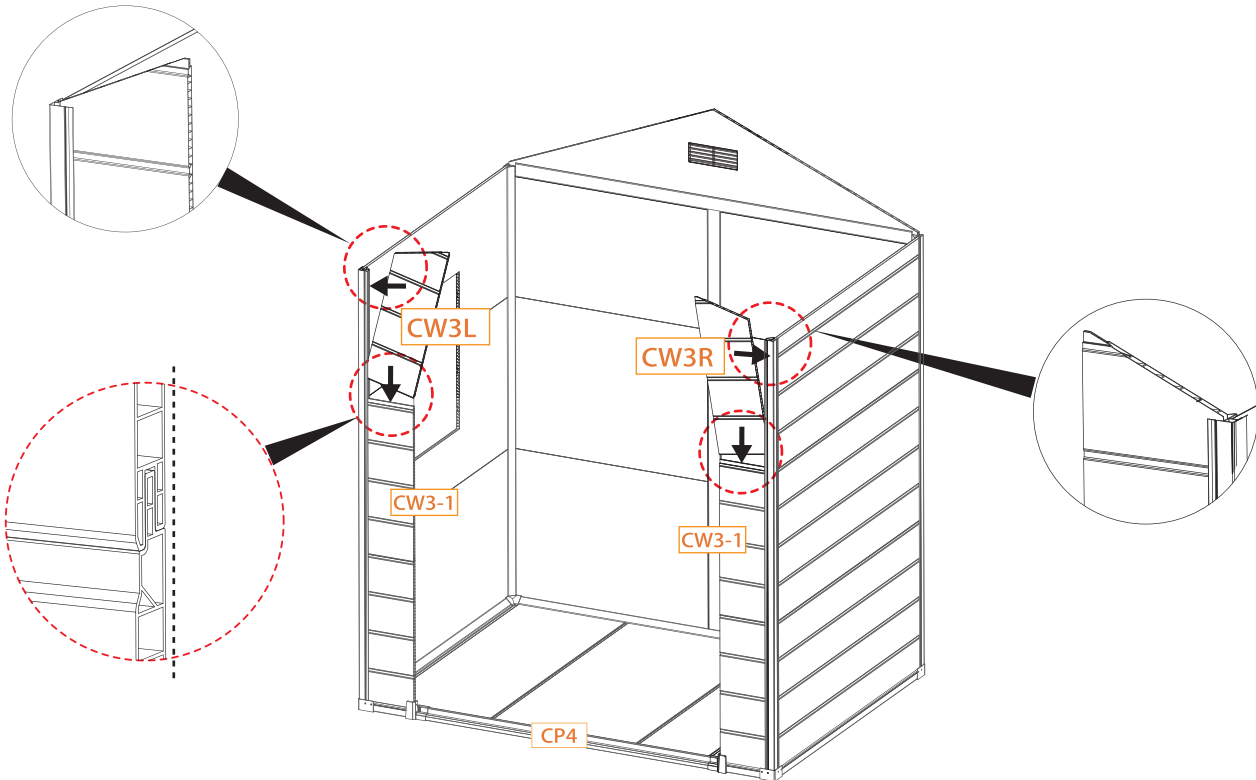
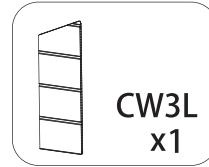

Step 22

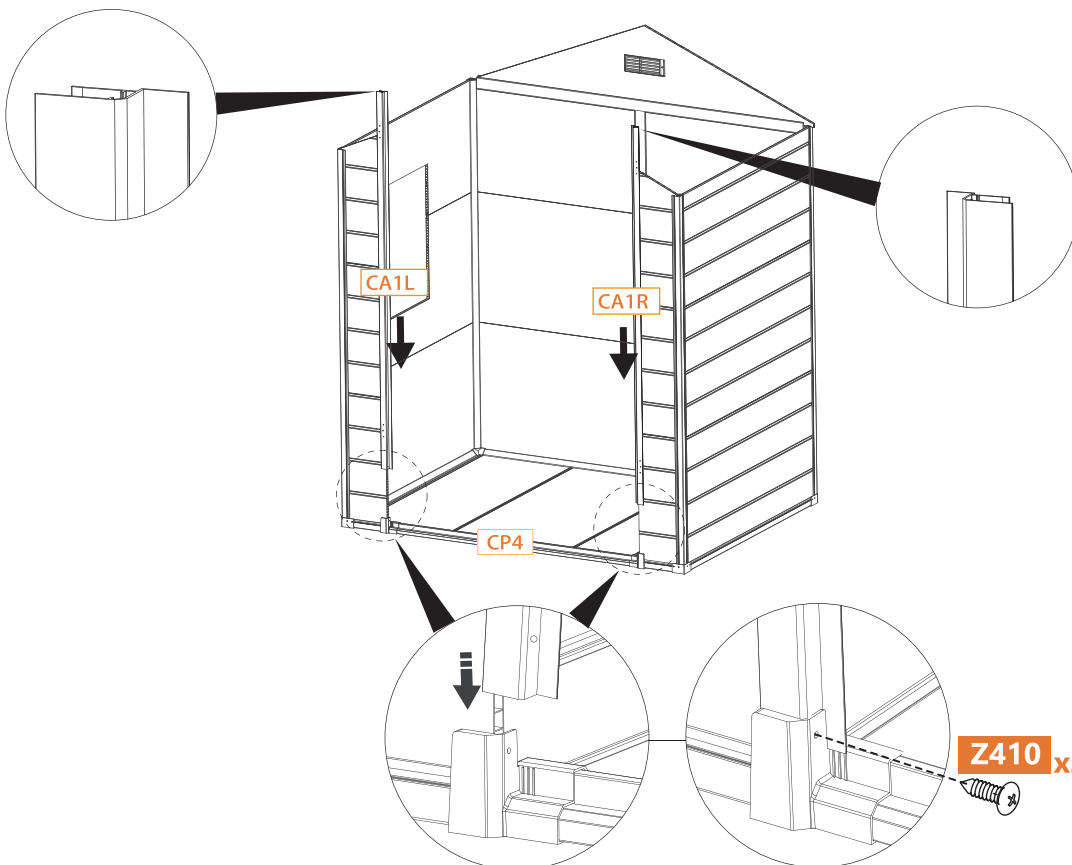
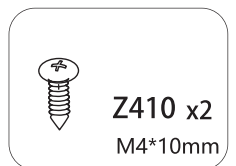

Step 23

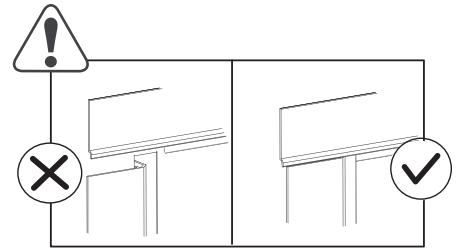
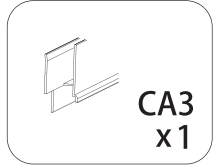
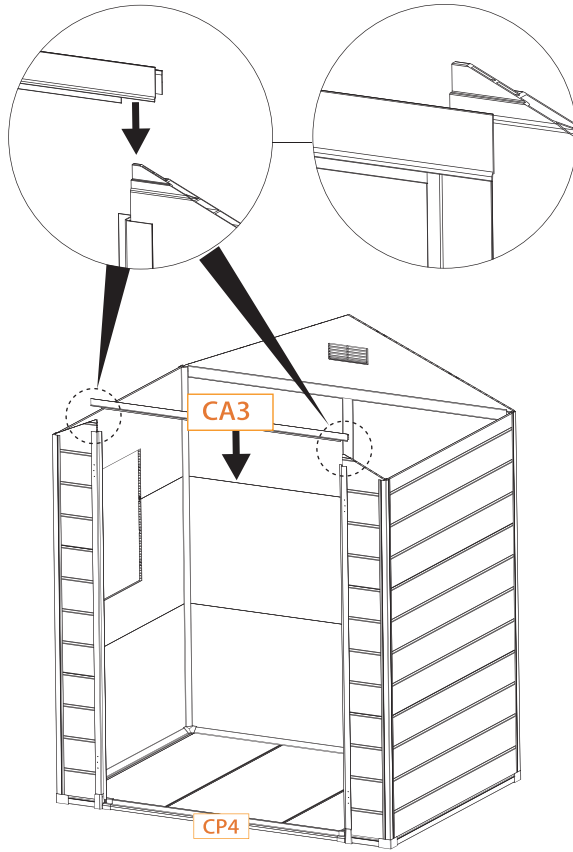

Step 24

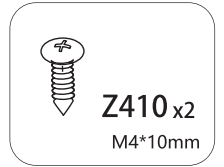
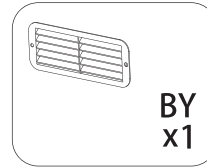
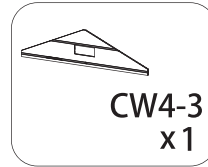

1

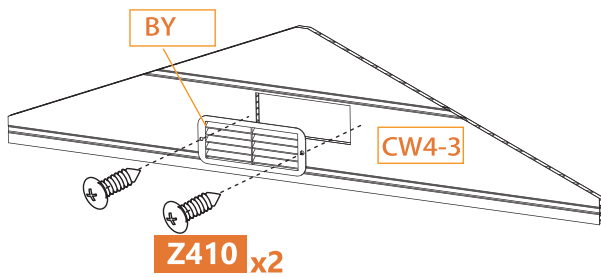

2

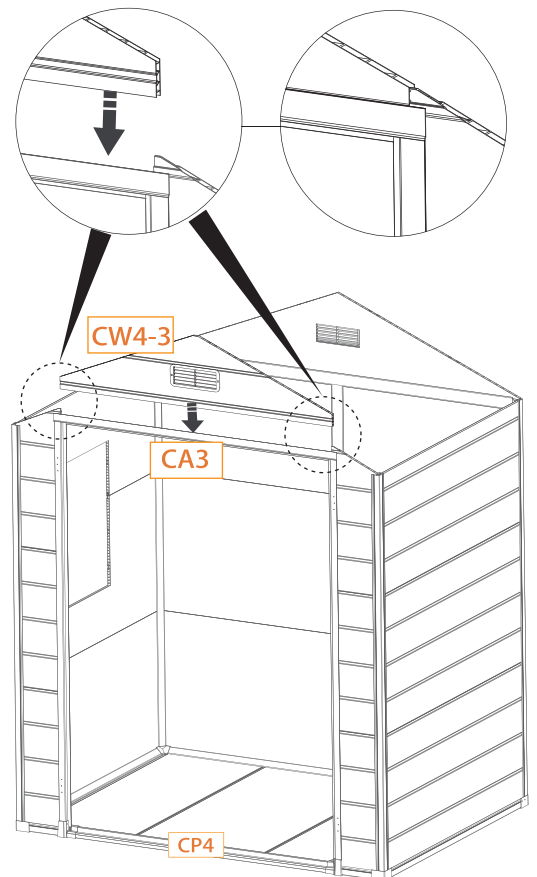

Step 25

AB=CD

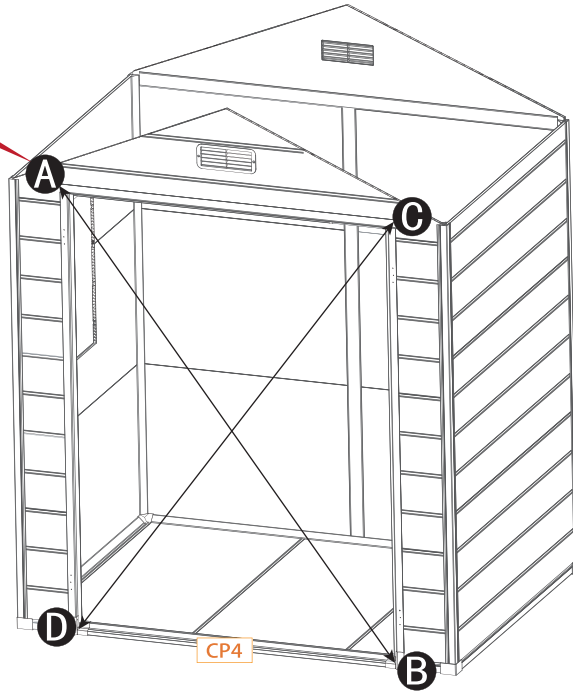

Step 26



● fixation after aligning

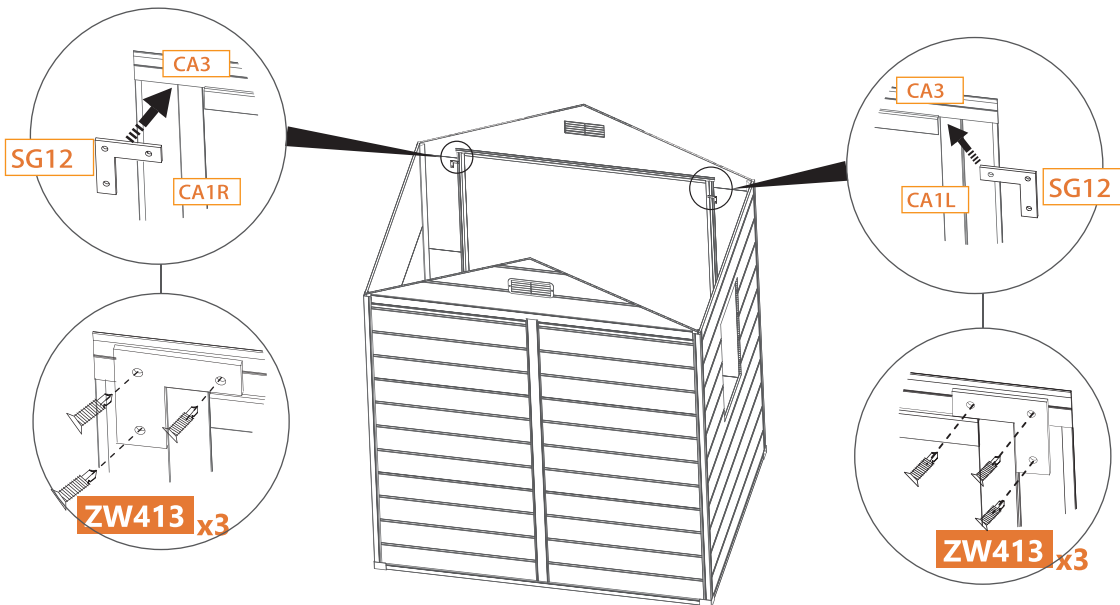
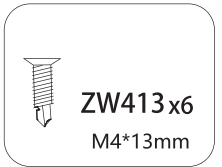
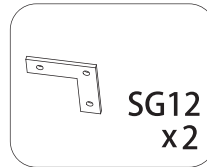
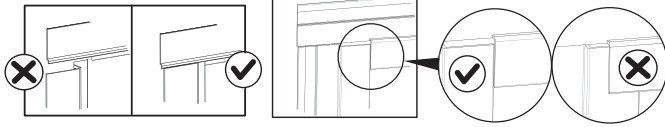

Step 27

Caution:

Please use Drill  to predrill a hole at depth 1mm before screw.



Screw when the boards are in position

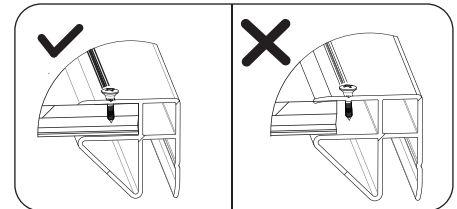
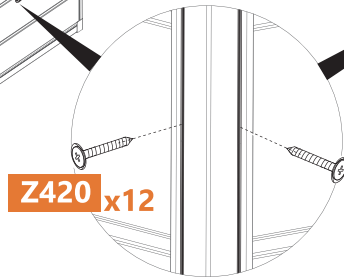
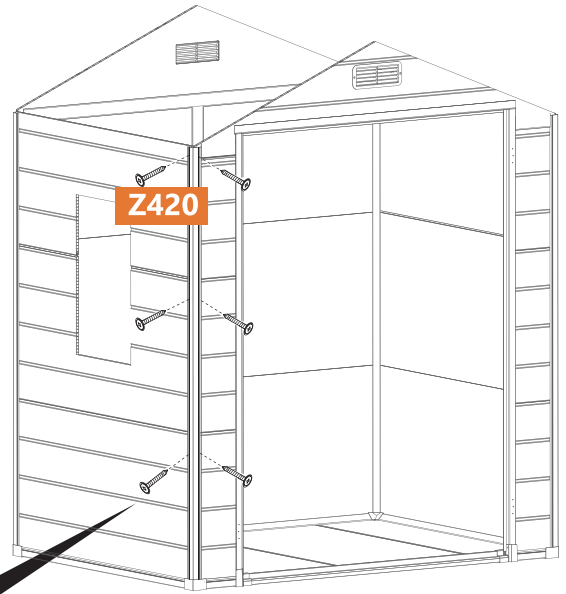

Fully fit the panel inside the profile
Screw along the marked lines in profiles

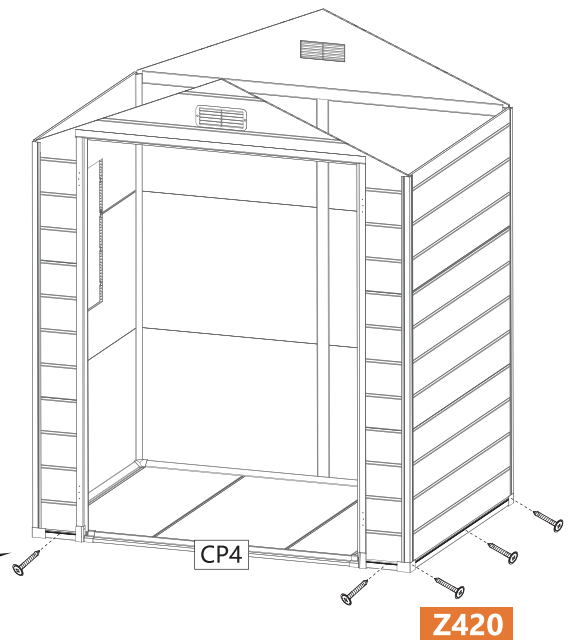
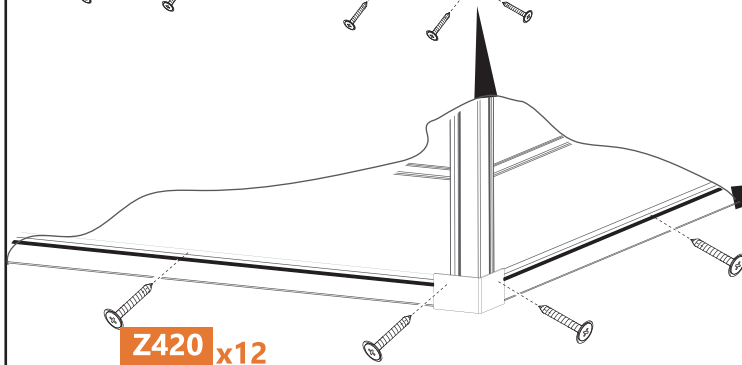
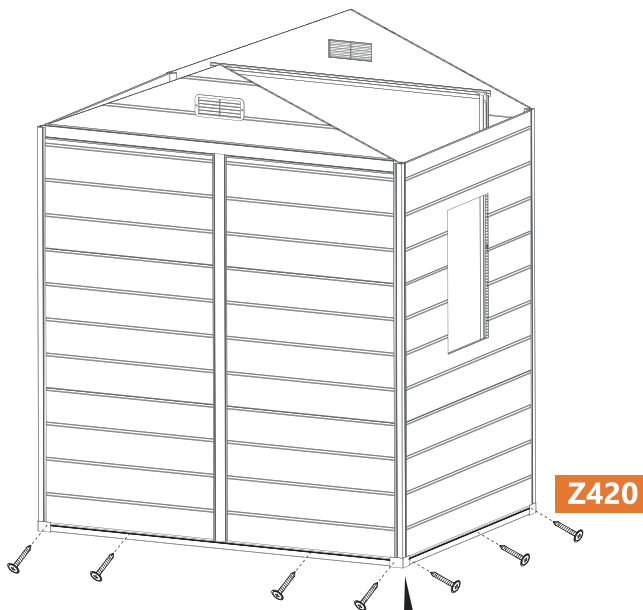

ROOF PARTS

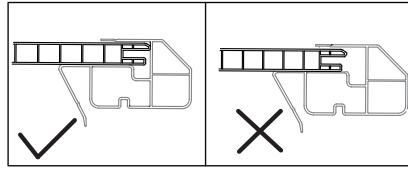

Fully fit the panel inside the profile

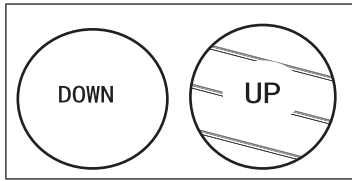
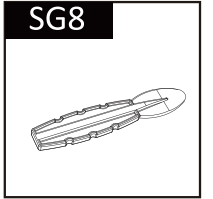
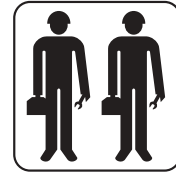

The stripes should be upwards

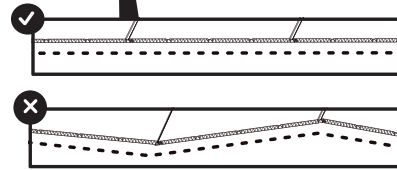
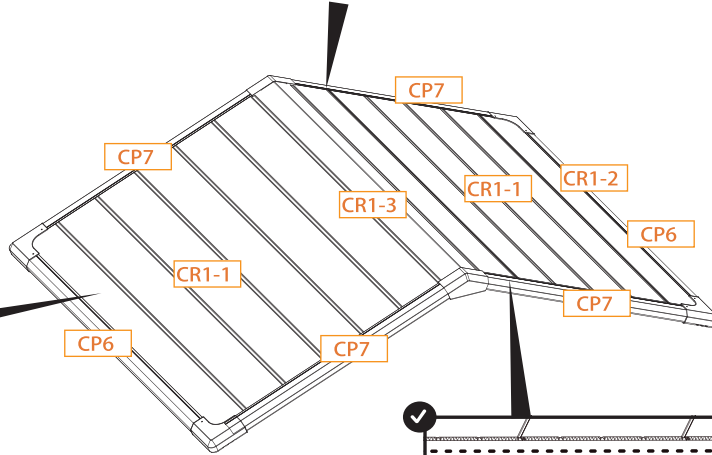

Step 28

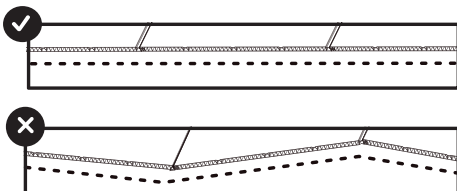
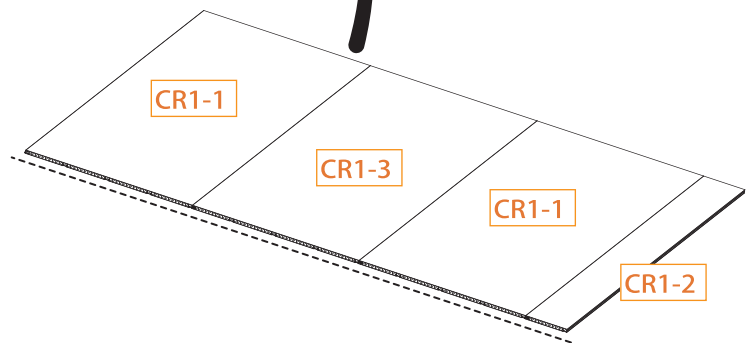
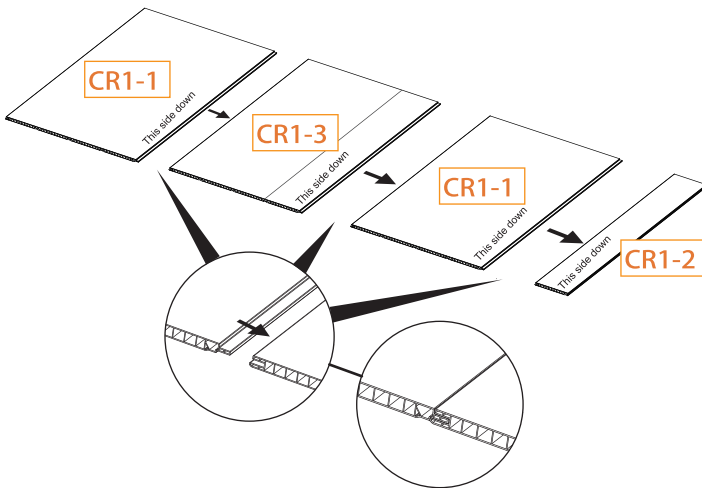
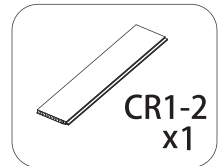
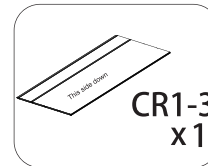
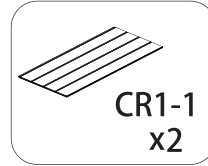

Step 29

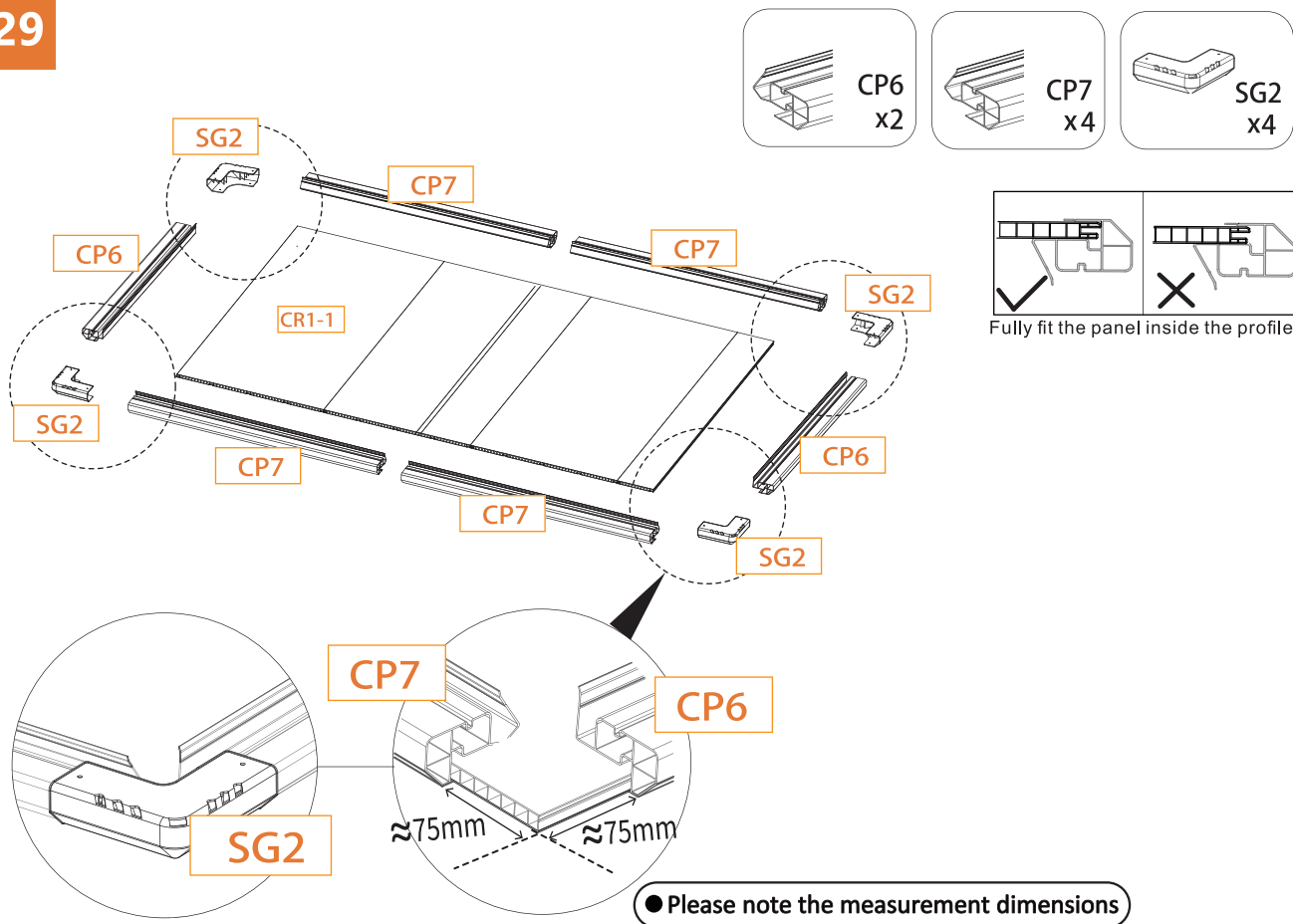

Step 30

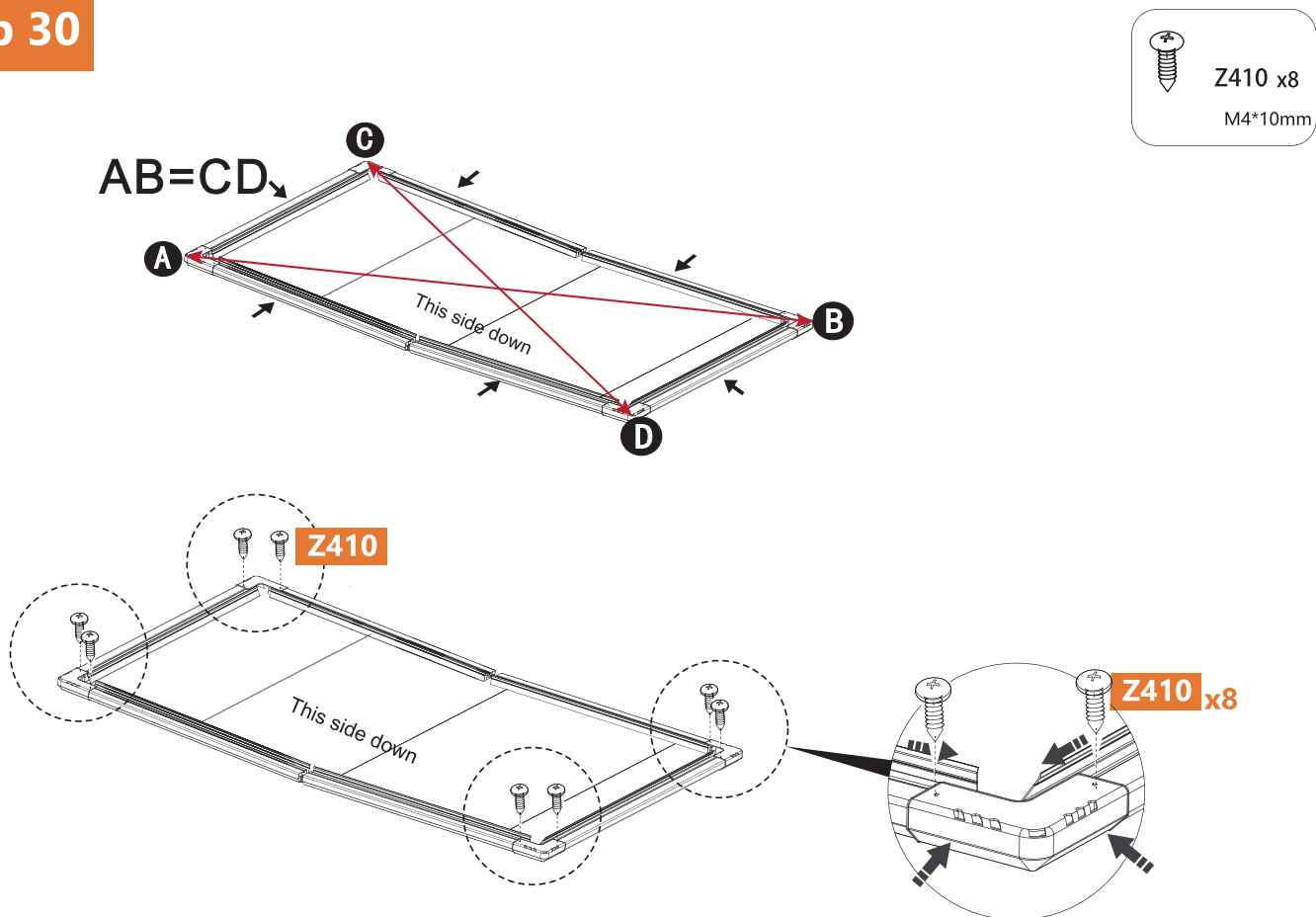

Step 31



Turn the roof boards over

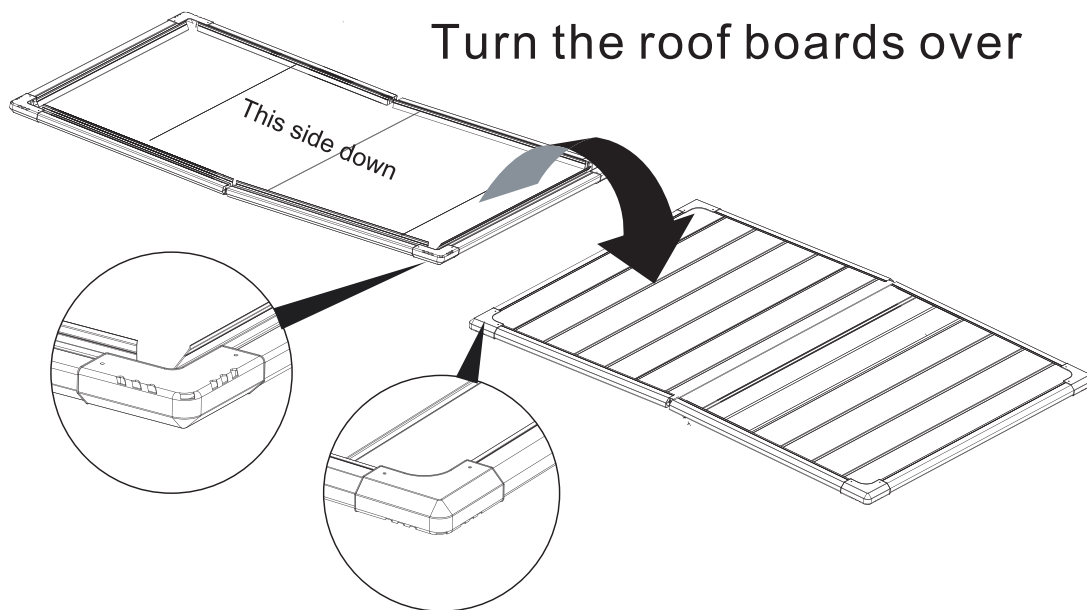

Step 32

Caution:

Please use Drill  to predrill a hole at depth 1mm before screw.

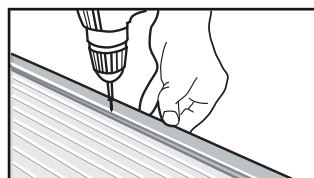

Screw along the marked lines in profile



Z420 x20
M4*20mm

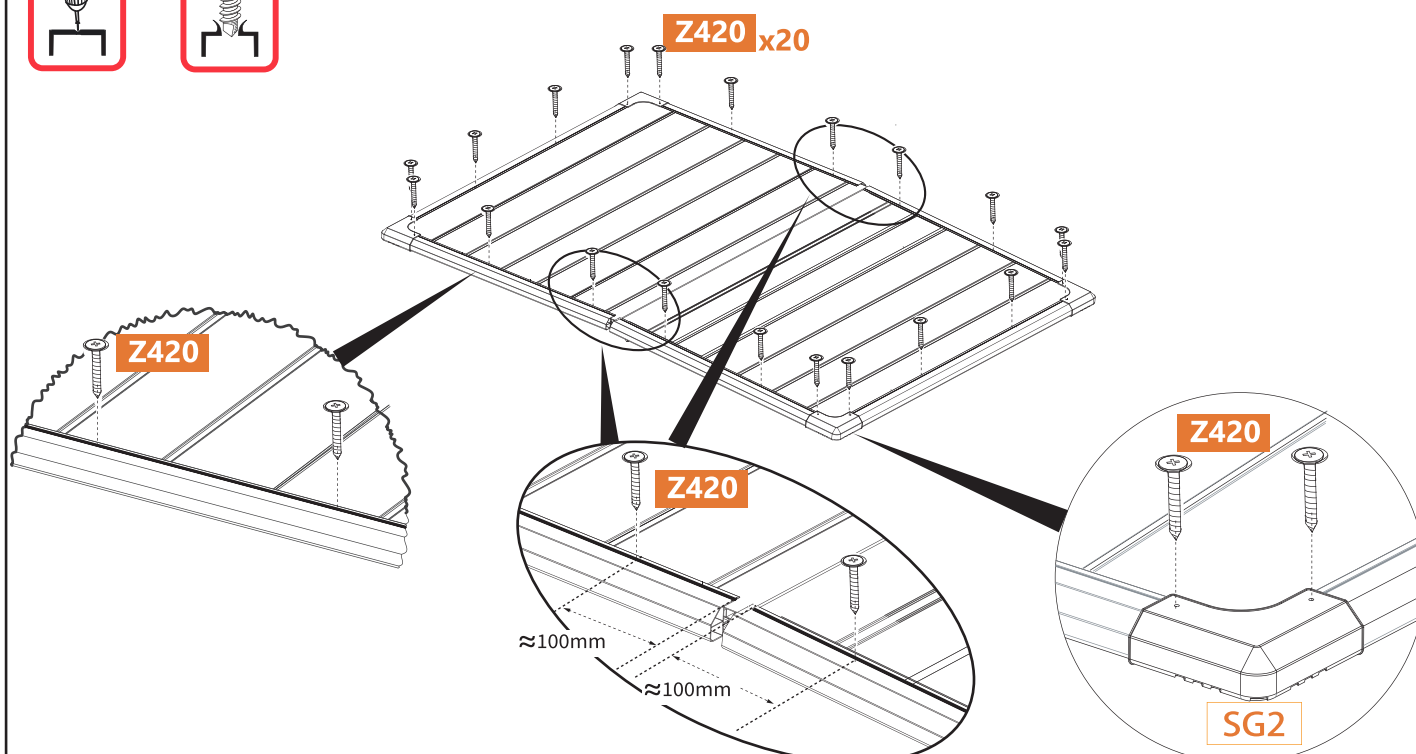

- The distance from the profile edge to the first screw is about 100mm.

Step 33

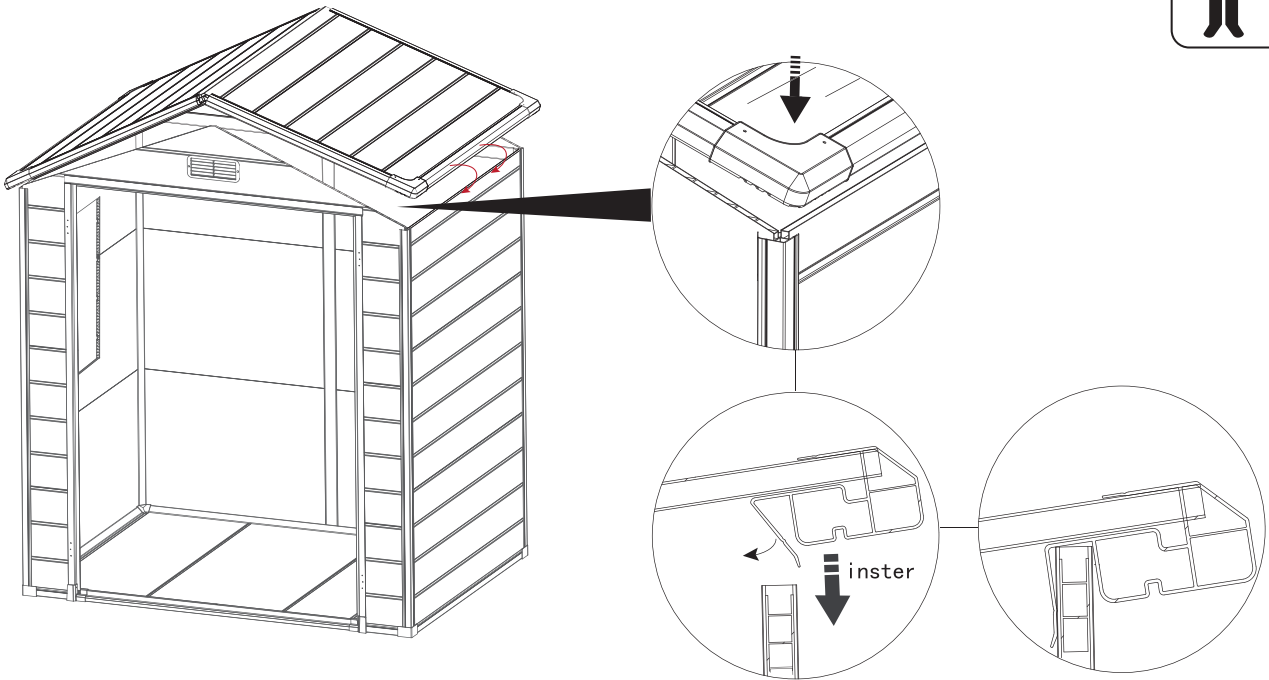

Fully fit the panel inside the profile

Step 34

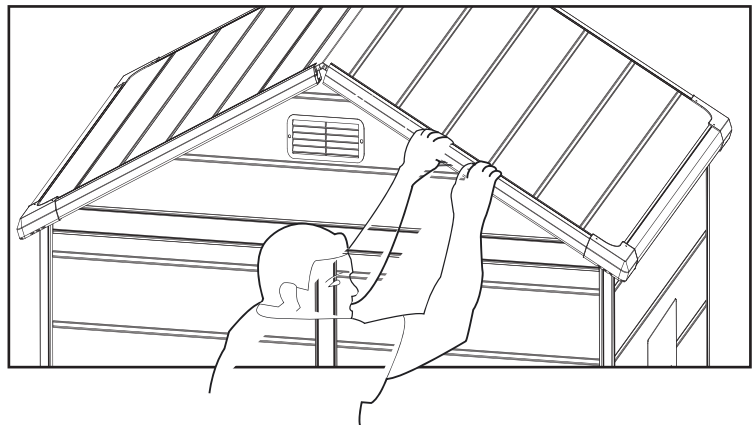
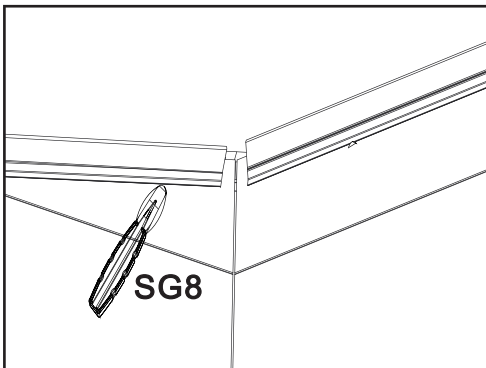

Fully fit the panels inside the profiles of roof

SG8 x2

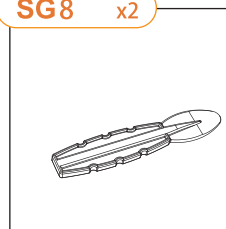

Step 35

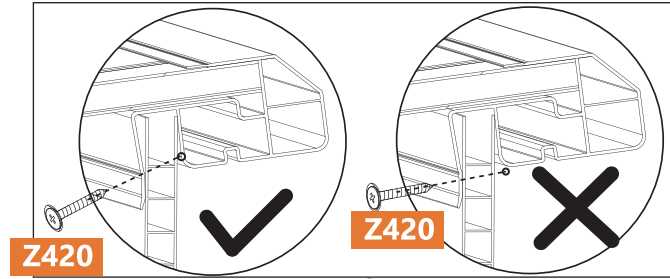
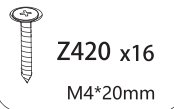

Caution:

Please use Drill  to predrill a hole at depth 1mm before screw.

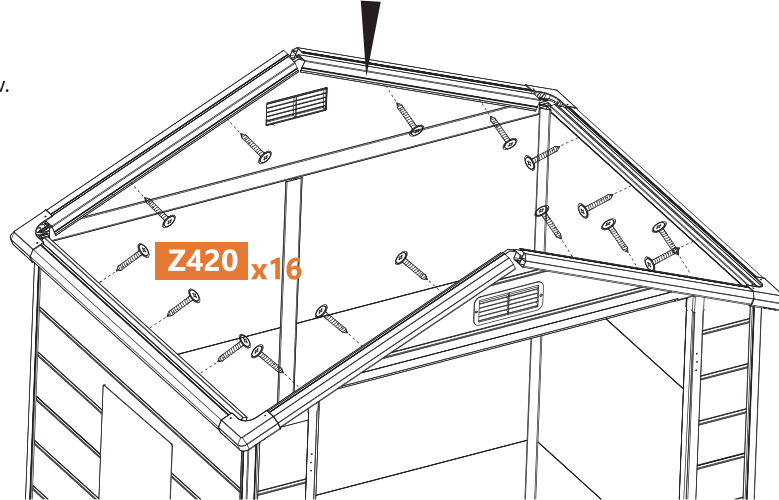

Step 36

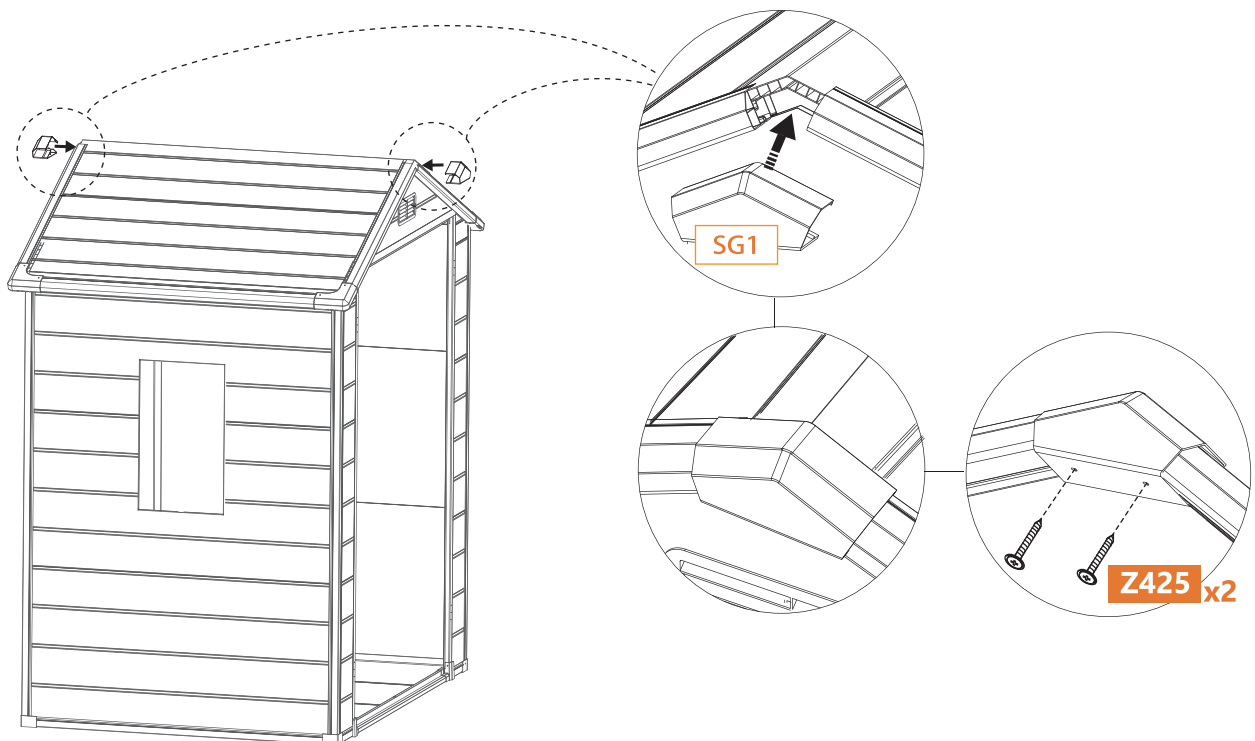

Step 37 Window section

SG10 x1 SG101 x1 SG102 x1 Z410 x16 M4*10mm

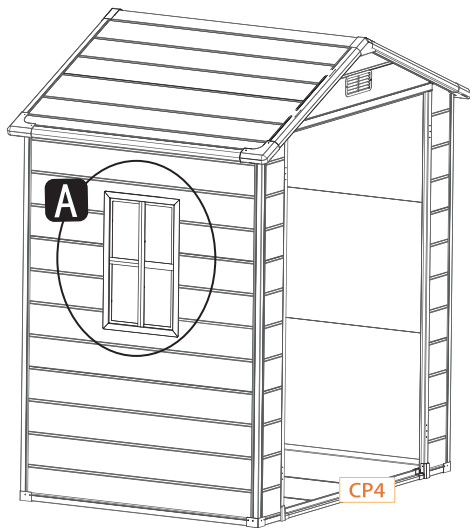

A-1

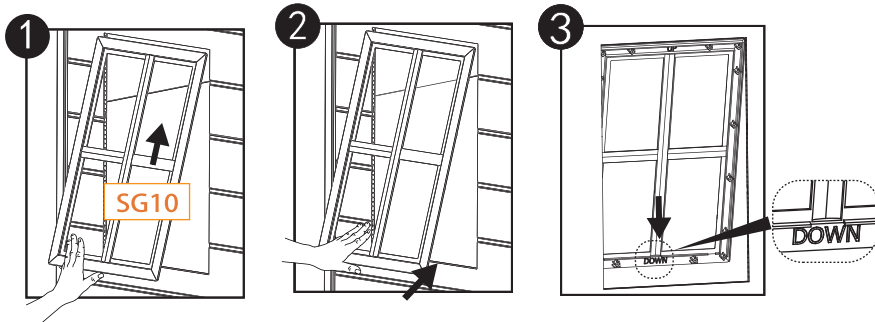

A-2

- Remove the film before fixing SG101
- Two persons are needed for this step, to press SG101 from outside and inside.

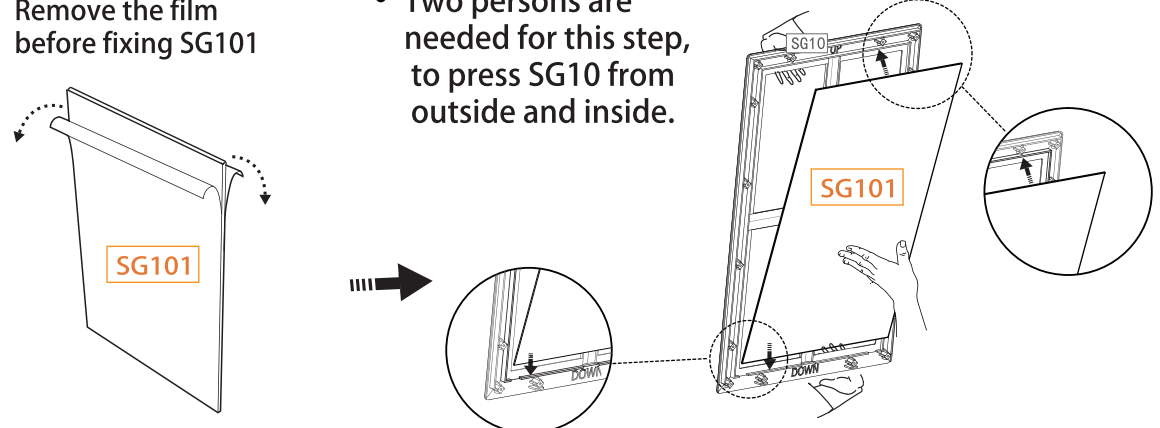

A-3

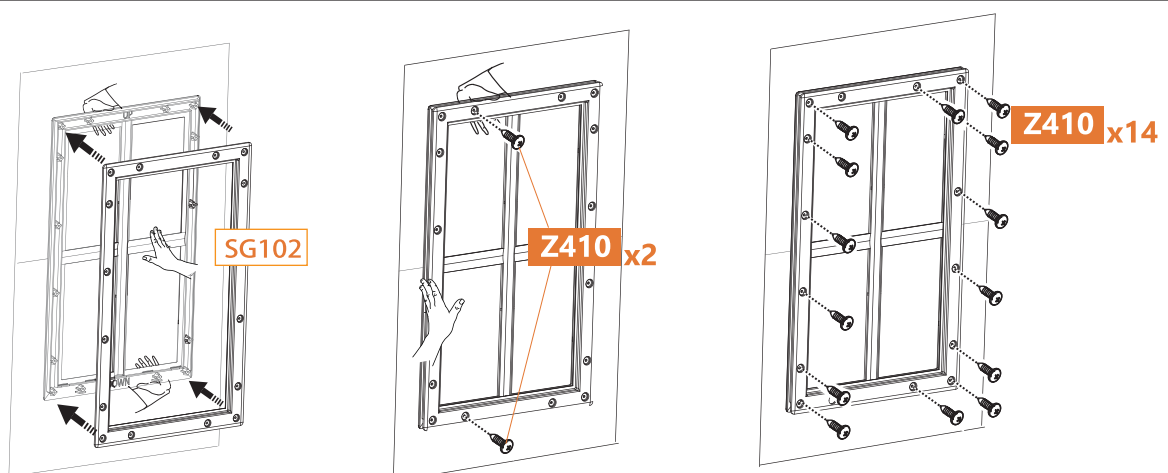

DOOR SECTION



Door mount this is above

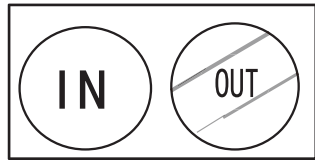
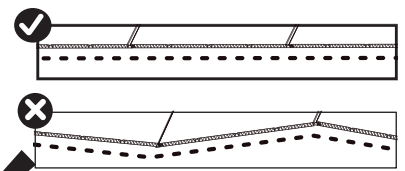
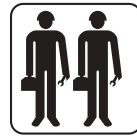

The stripes should be outside

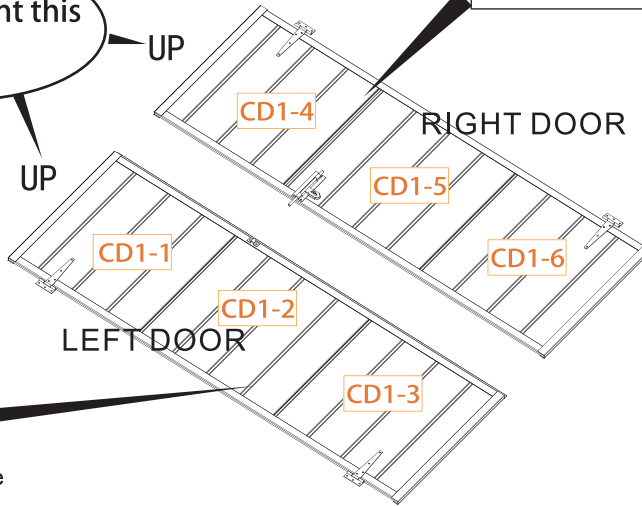

Step 38

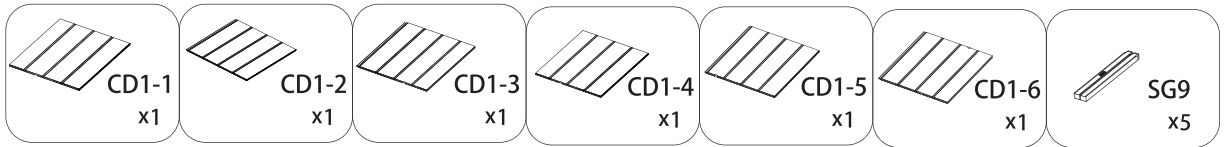

1

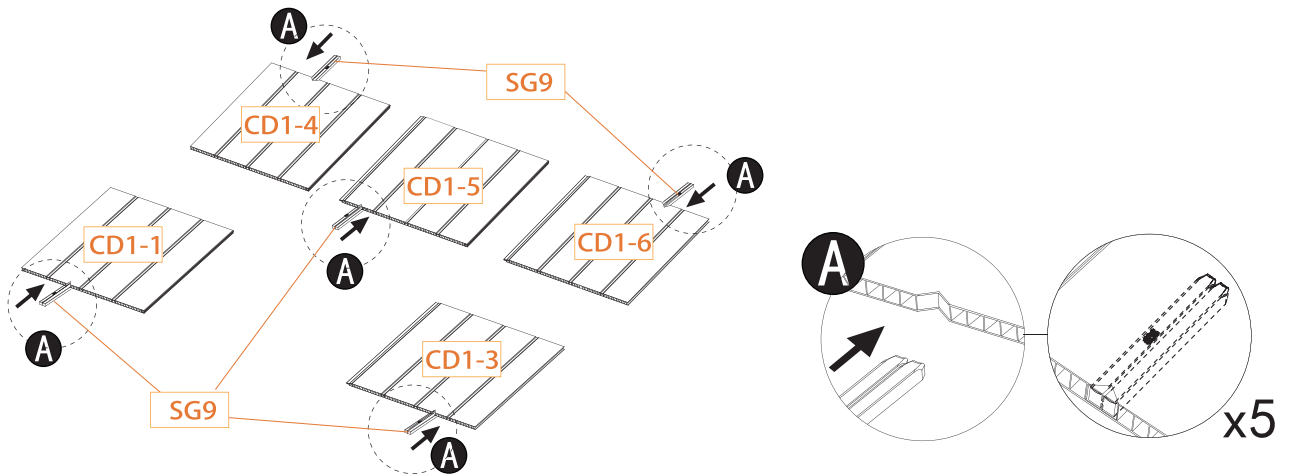

2

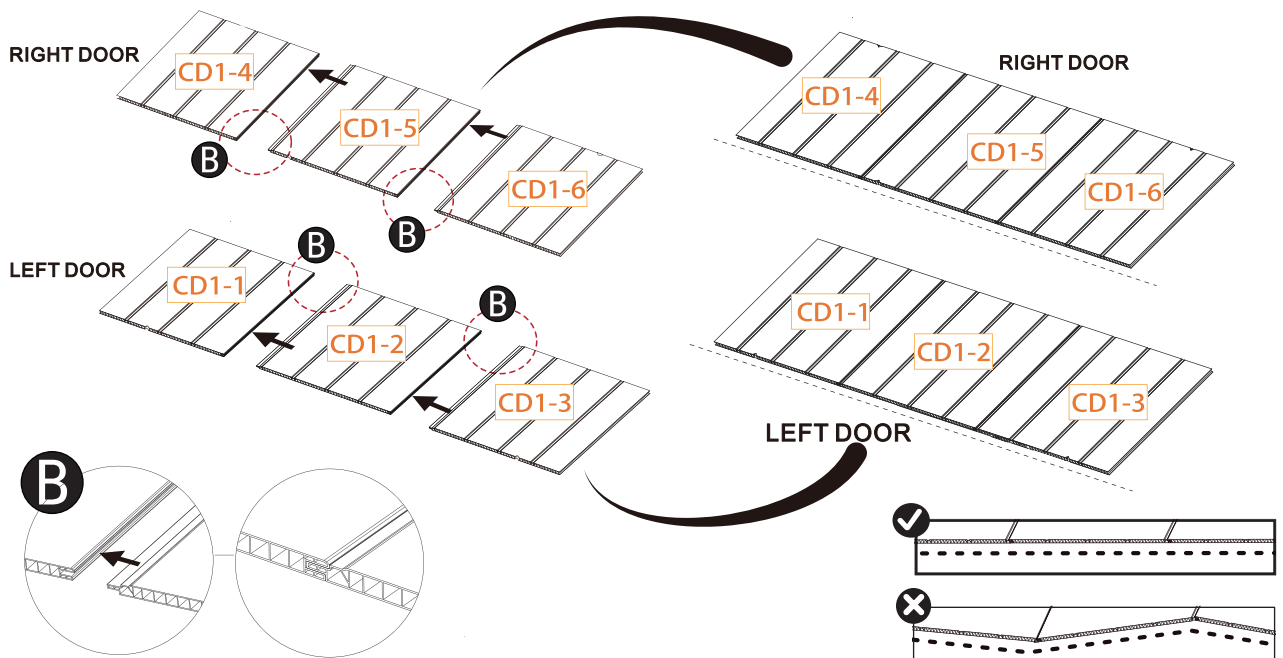

Step 39

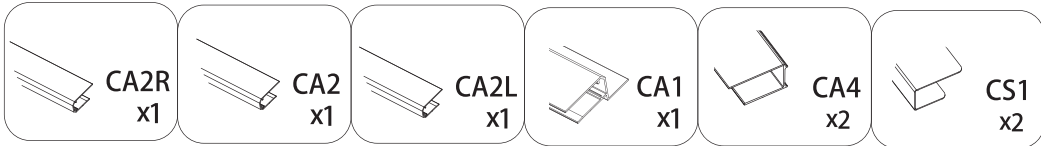

1

LEFT DOOR

RIGHT DOOR

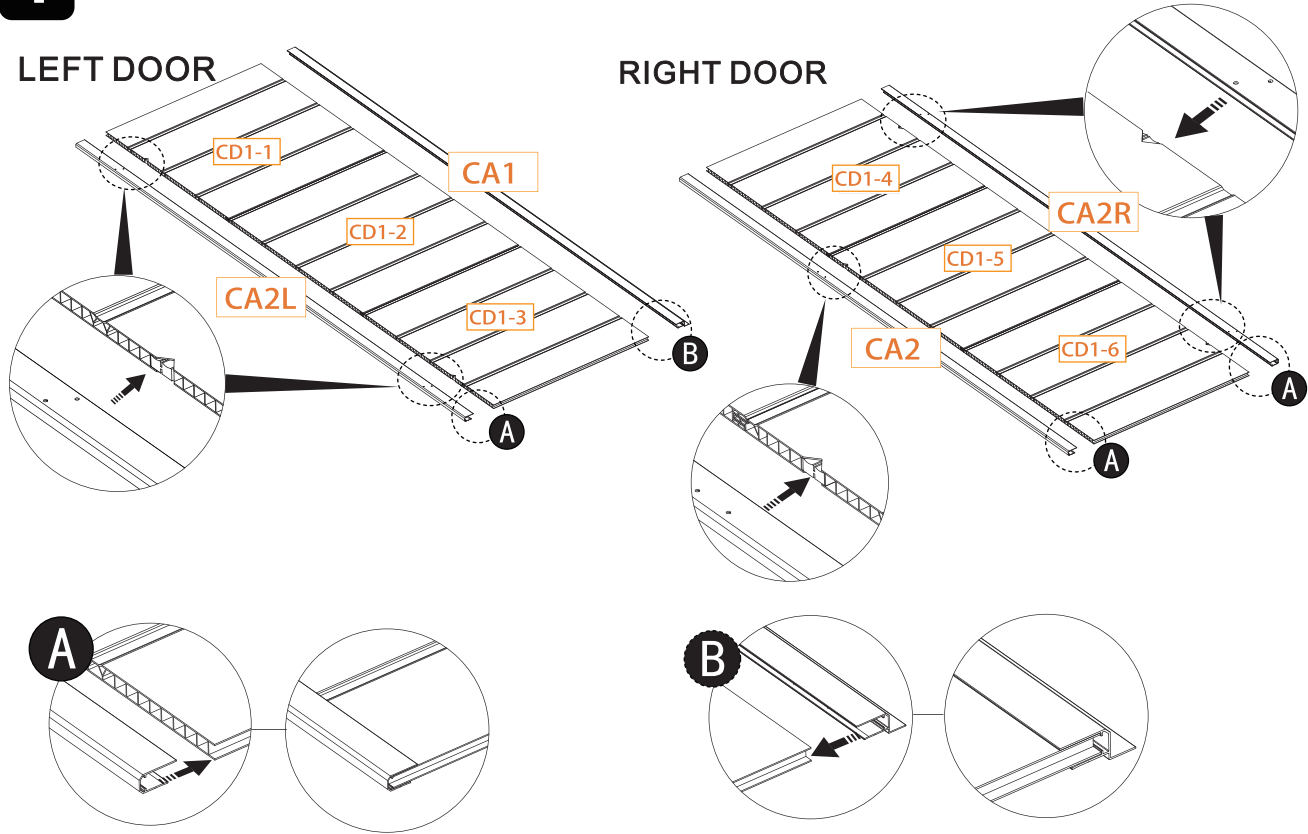

2

LEFT DOOR

RIGHT DOOR

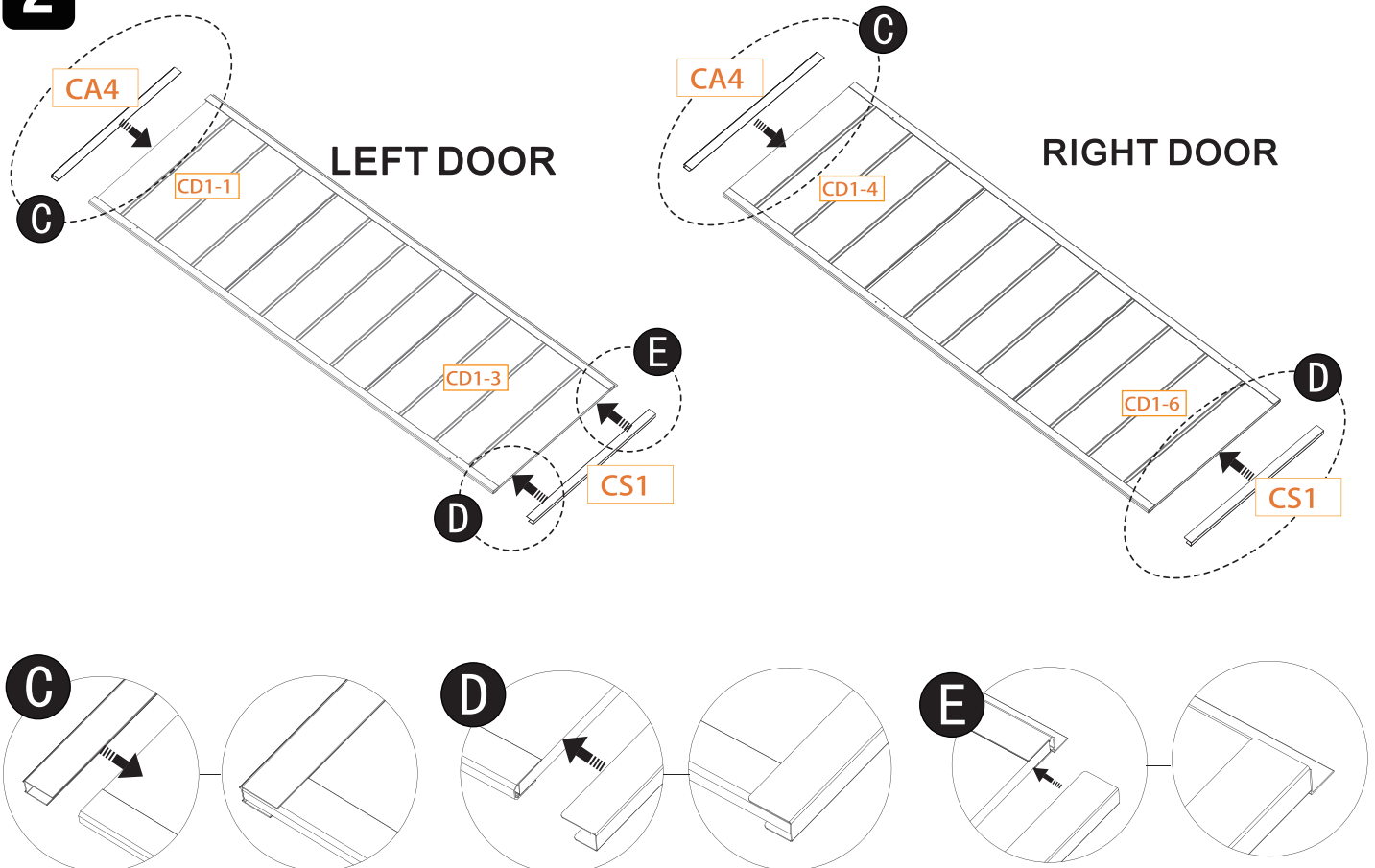

Step 40

Turn the doors over

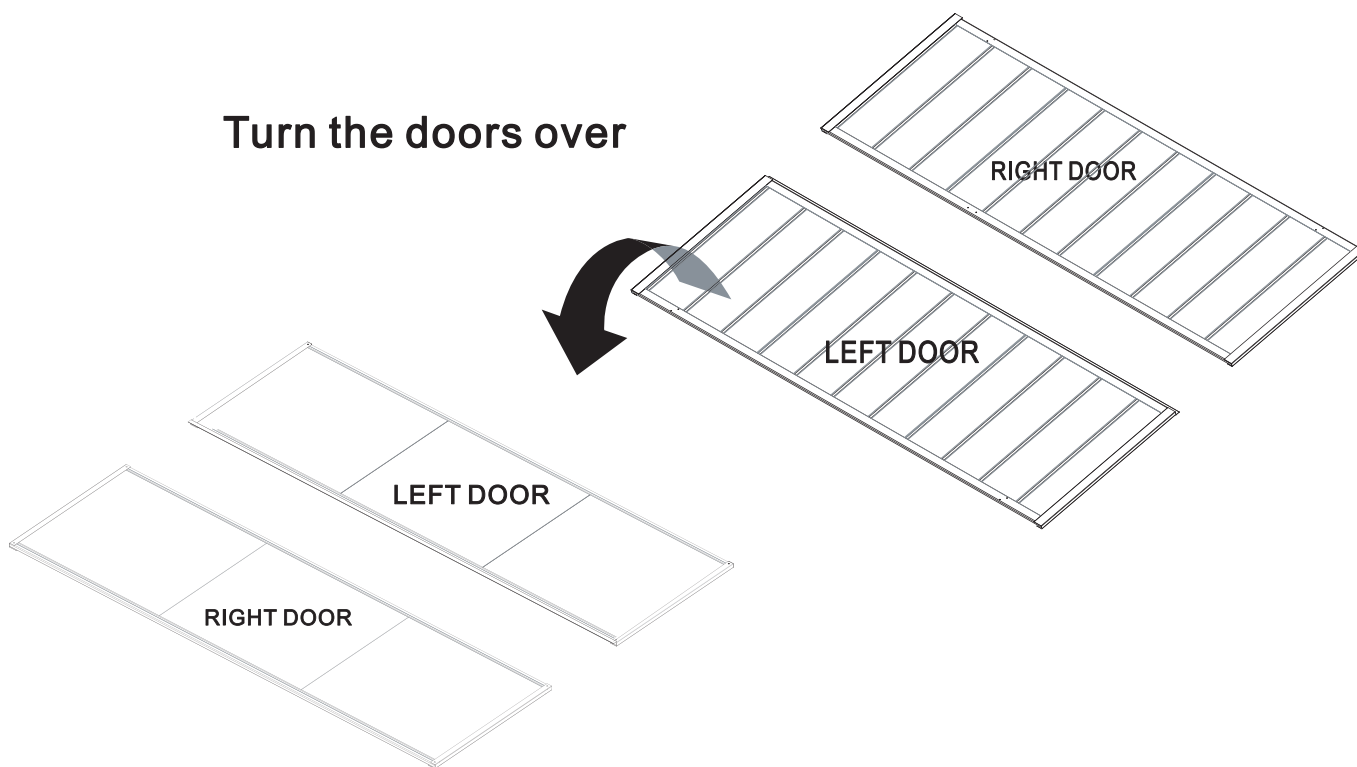

Step 41

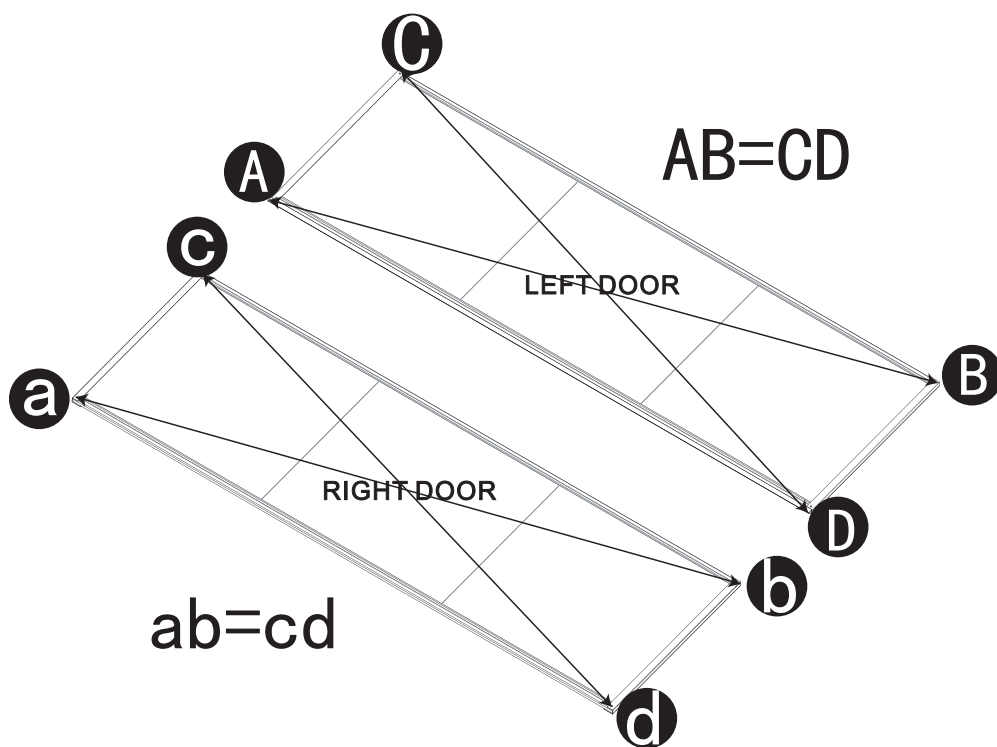

Step 42

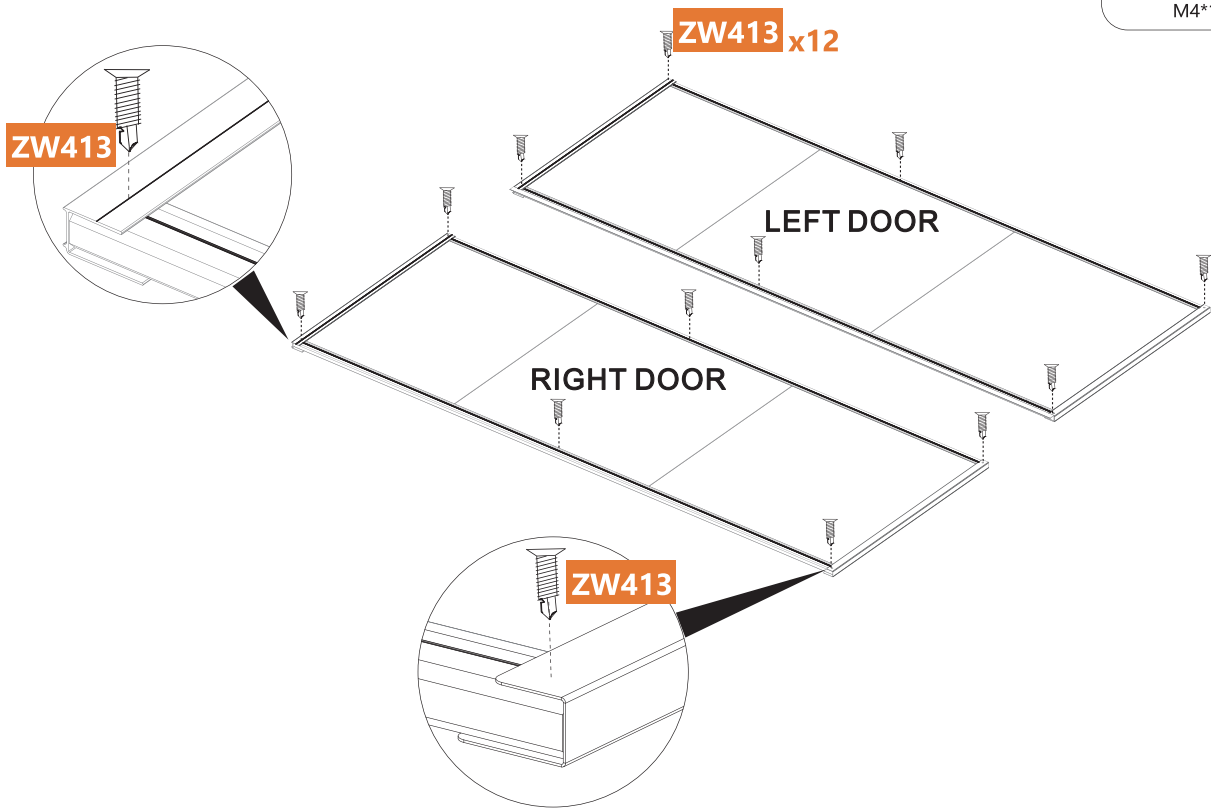
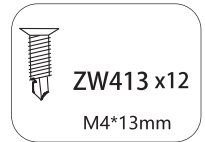

Step 43

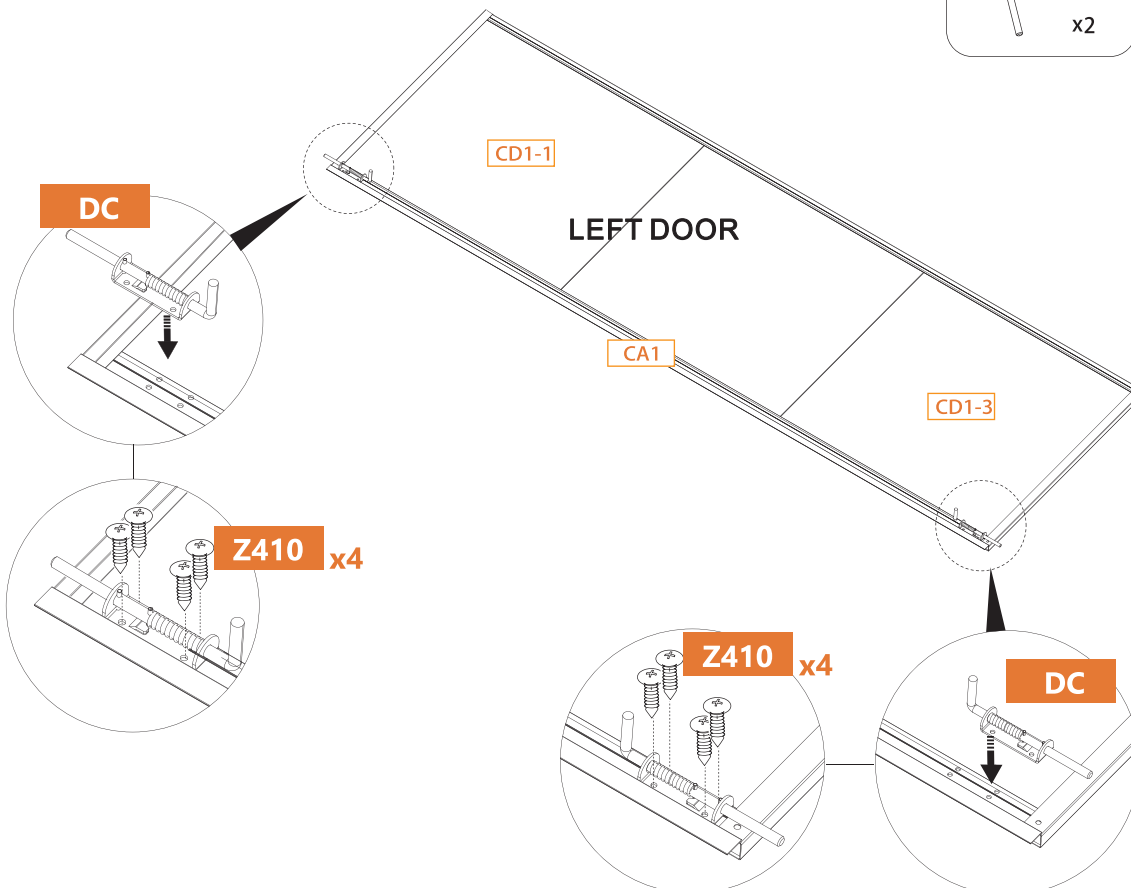
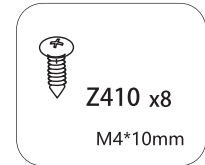
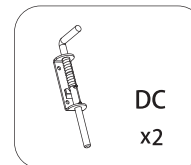

Step 44

Turn the doors over

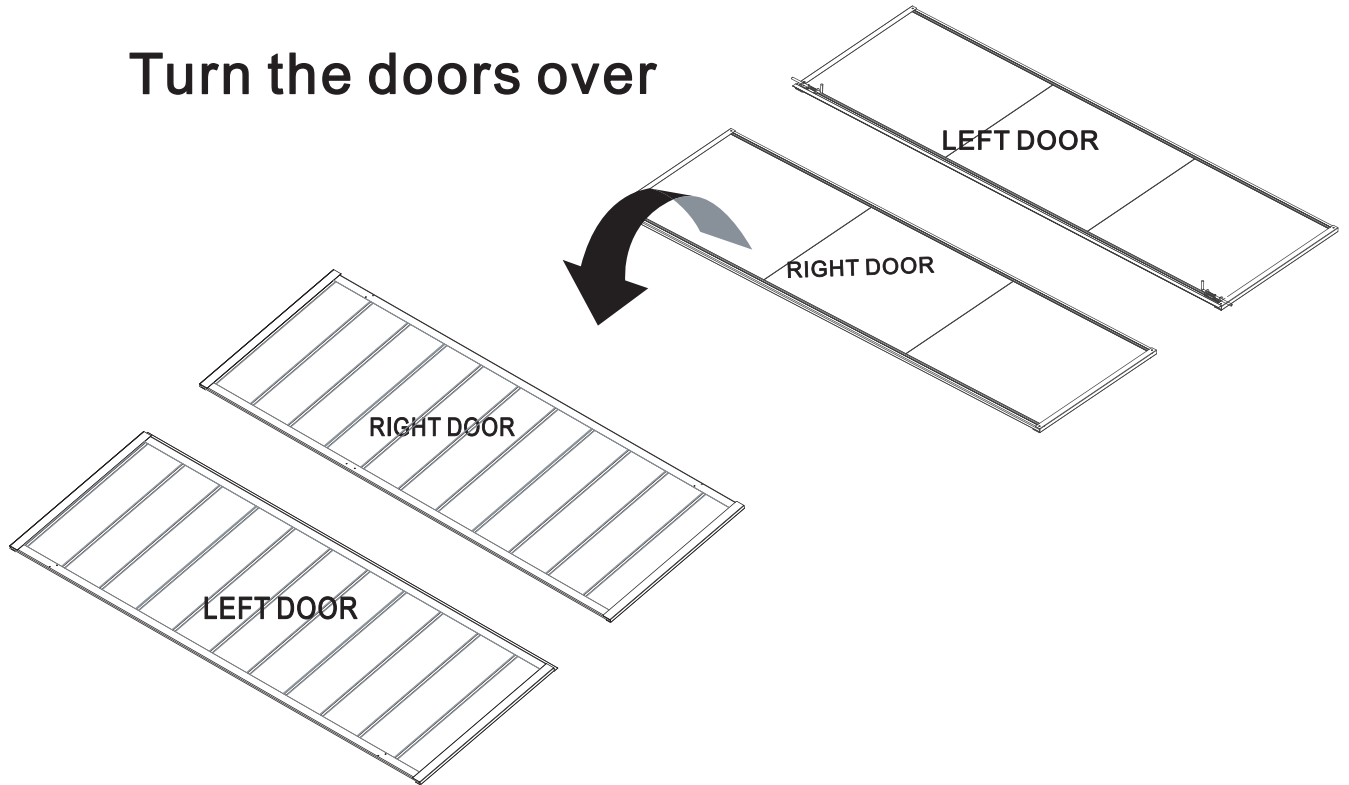

Step 45

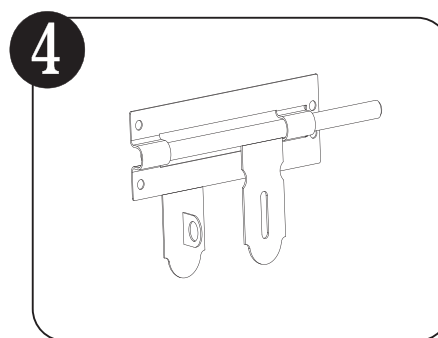
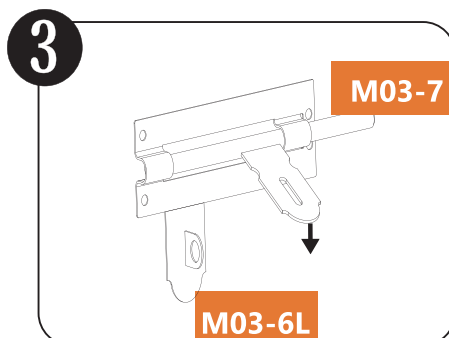
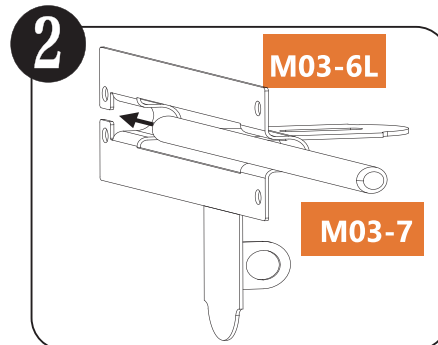
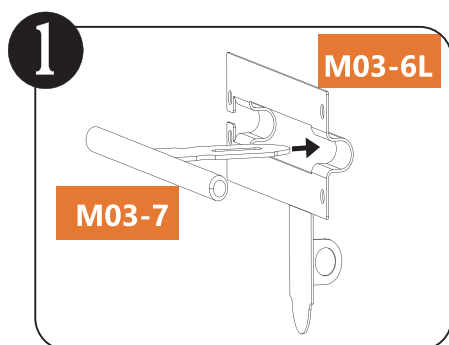
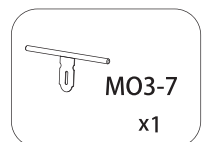
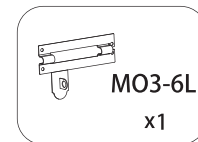

Step 46

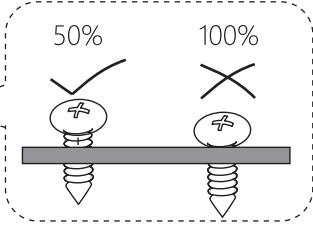
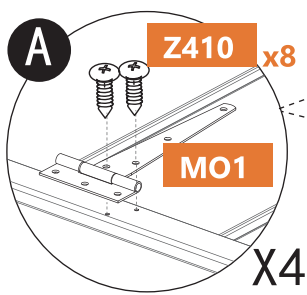
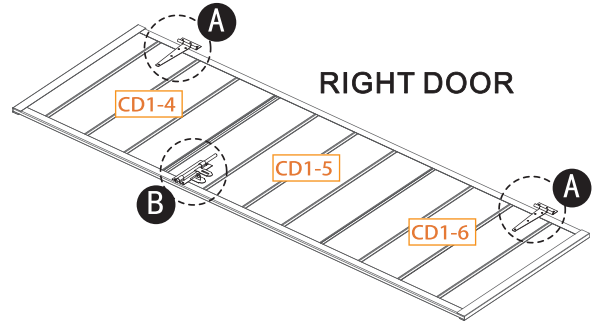
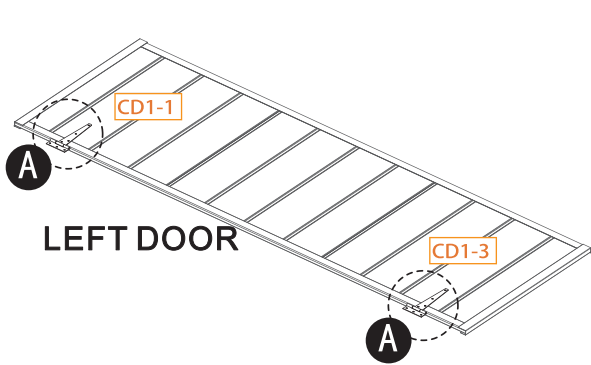
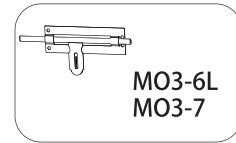
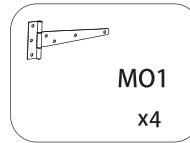
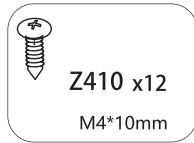

Don't fasten the screws in this step, to adjust the positions of doors

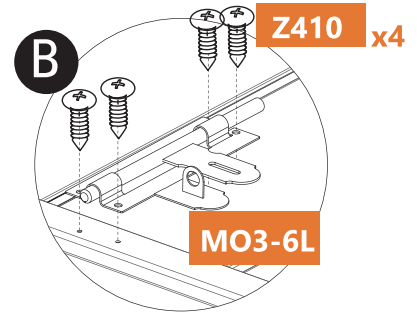

Step 47

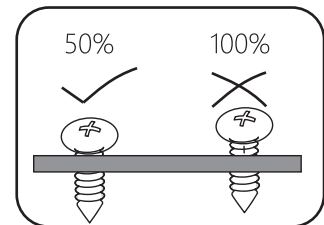
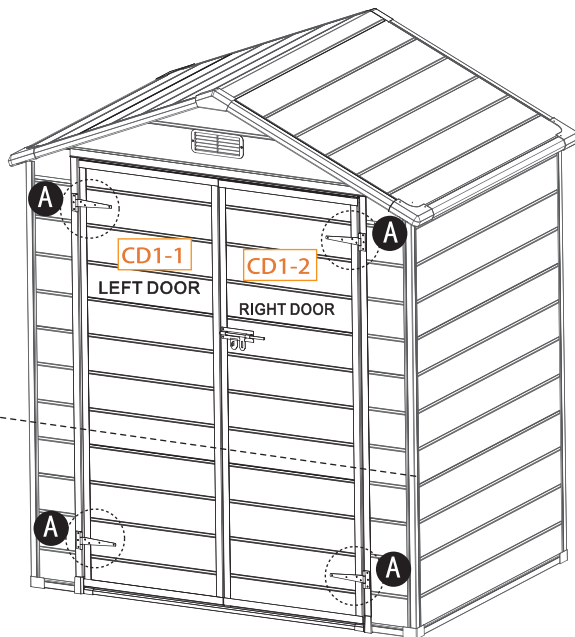
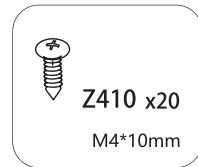
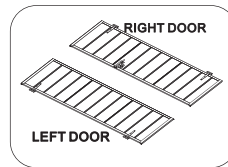

Nail the door after place adjustment and fasten all the screws

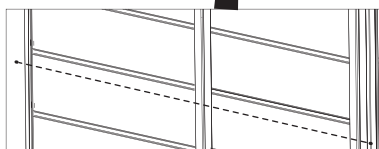

The joints of both left and right door should be in line

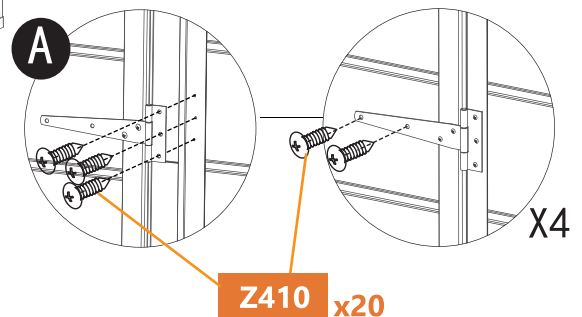

Step 48

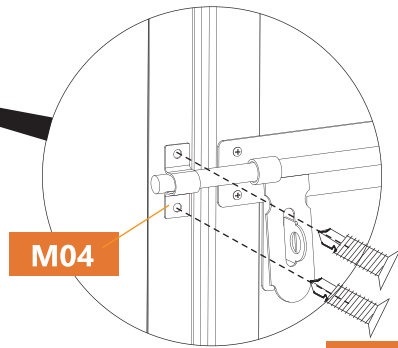
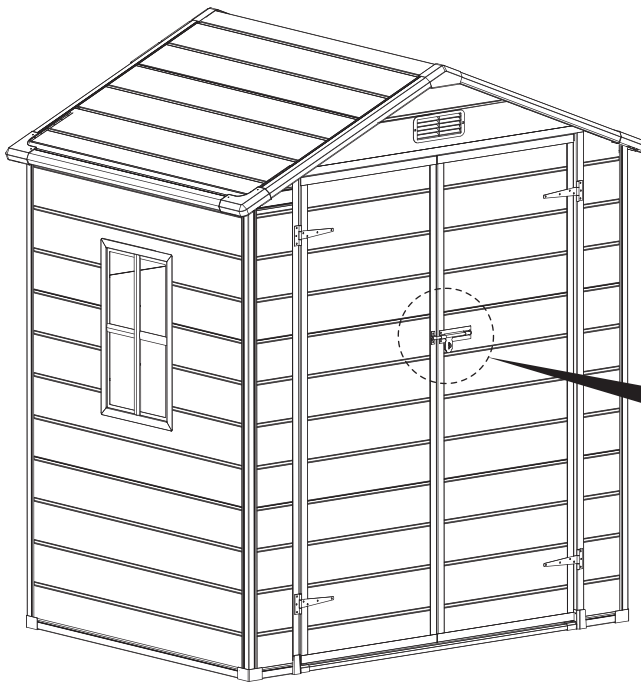
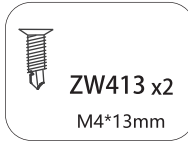

ZW413 x2

Step 49

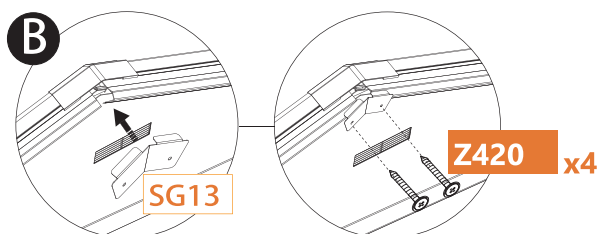
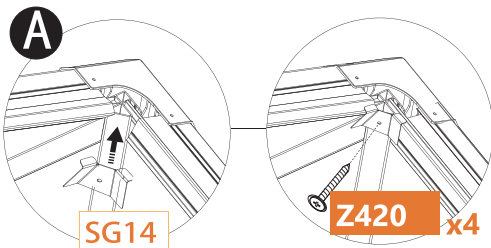
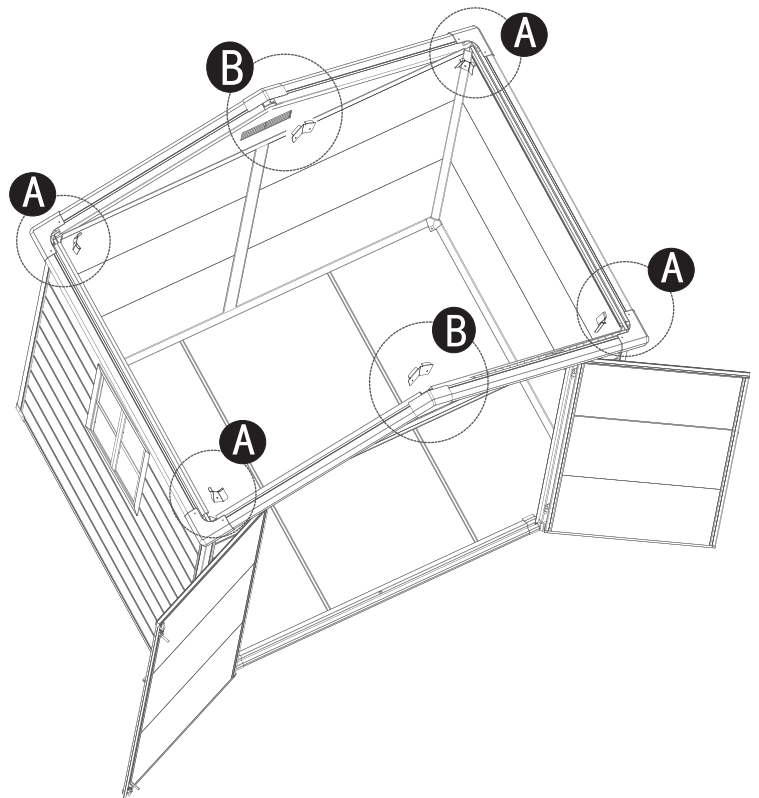
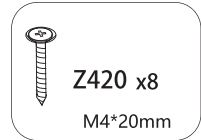

Step 50

