

ASSEMBLY INSTRUCTIONS

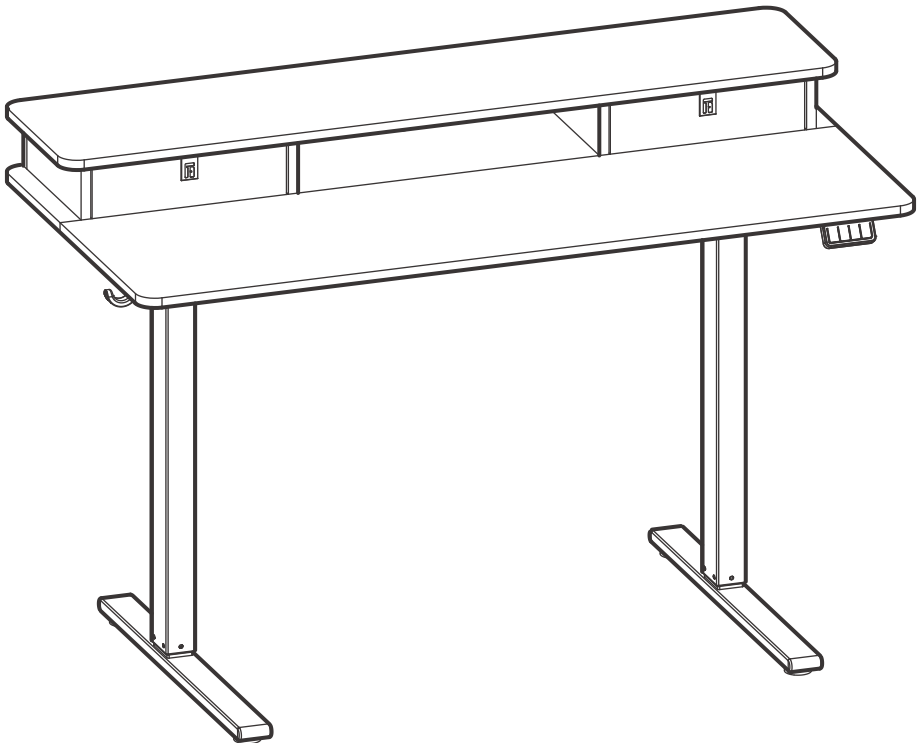

English

Caution

- Keep children and animals away from the desk during use. Ensure the desktop is not touching any walls.
- Remove obstacles taller than 20"/51cm from underneath the desk.
- Operate only in a working environment temperature of 32°F-104°F/0°C-40°C.
- Keep product away from corrosive gases, liquids and dusty objects.
- Keep hands, feet and other body parts in a safe position during operation. Anti-collision is not automatically enabled during all resets.
- The company does not bear any warranty or liability for damage and human injury caused by any abnormal or un-intended operation of the equipment.
- It is necessary to perform a manual reset after the initial installation or power cycling the equipment.

Español

Precaución

- Mantenga a los niños y animales alejados del escritorio durante su uso. Asegúrese de que el escritorio no toca ninguna pared.
- Retire aquellos obstáculos con una altura superior a 20"/51cm de debajo del escritorio.
- Opérela únicamente en una temperatura del entorno de trabajo de 32°F-104°F/0°C-40°C.
- Mantenga el producto alejado de gases corrosivos, líquidos y objetos con polvo.
- Mantenga las manos, pies y otras partes del cuerpo en una posición segura durante el funcionamiento. No se habilita la anticollisión de forma automática tras los reinicios.
- La empresa no ofrece ninguna garantía no asume ninguna responsabilidad por cualquier daño o lesión humana provocada por un funcionamiento anormal o no previsto del equipo.
- Es necesario realizar un reinicio manual tras la instalación inicial o el ciclo de encendido.

Italiano

Attenzione

- Tenere i bambini e gli animali lontani dalla scrivania durante l'uso. Assicurarsi che il piano non tocchi alcuna parete.
- Rimuovere gli ostacoli più alti di 20"/51cm da sotto la scrivania.
- Operare solo in un ambiente di lavoro con una temperatura di 32°F-104°F/0°C-40°C.
- Tenere il prodotto lontano da gas e liquidi corrosivi e oggetti polverosi.
- Tenere mani, piedi e altre parti del corpo in posizione di sicurezza durante il funzionamento. L'anti-collisione non è automaticamente attivata dopo il ripristino.
- La società non si assume alcuna garanzia o responsabilità per danni e lesioni umane causati da un funzionamento anormale o non previsto dell'apparecchiatura.
- È necessario eseguire un ripristino manuale dopo l'installazione iniziale o il ciclo di alimentazione.

Deutsch

Vorsicht

- Halten Sie Kinder und Tiere während der Benutzung vom Tisch fern. Achten Sie darauf, dass die Tischplatte keine Wände berührt.
- Entfernen Sie Hindernisse, die höher als 20"/51cm Zoll sind, von der Unterseite des Tisches.
- Betreiben Sie das Gerät nur in einer Arbeitsumgebung mit einer Temperatur von 32°F-104°F/0°C-40°C.
- Halten Sie das Produkt von ätzenden Gasen, Flüssigkeiten und staubigen Gegenständen fern.
- Halten Sie Hände, Füße und andere Körperteile während des Betriebs in einer sicheren Position. Der Antikollisionsschutz wird nach den Zurücksetzen nicht automatisch aktiviert.
- Das Unternehmen übernimmt keine Garantie oder Haftung für Schäden und Verletzungen, die durch einen abnormalen oder unbeabsichtigten Betrieb des Geräts verursacht werden.
- Nach der Erstinstallation oder dem Ersteinhalten der Stromversorgung muss eine manuelle Rückstellung vorgenommen werden.

Français

Attention

- Pendant l'utilisation, gardez les enfants et les animaux à l'écart du bureau. Veillez à ce que le bureau ne touche aucun mur.
- Éliminez les obstacles de plus de 20"/51cm pouces de hauteur sous le bureau.
- N'utilisez le produit que dans un environnement de travail dont la température est comprise entre 32°F-104°F/0°C-40°C.
- Éloignez le produit de toute source de gaz corrosifs, de liquides et d'objets poussièreux.
- Gardez les mains, les pieds et les autres parties du corps dans une position sûre lorsque vous utilisez l'appareil. L'anticollision n'est pas automatiquement activée après les réinitialisations.
- Aucune garantie ou responsabilité n'est assumée par la société pour les dommages et les blessures humaines causés par un fonctionnement anormal ou non intentionnel de l'équipement.
- Une réinitialisation manuelle est indispensable après l'installation initiale ou un cycle d'alimentation.

日本語

注意

- 本製品を使用している時、子供や動物から遠ざけてください。デスクトップが壁に触れていないことを確認してください。
- 机の底から20インチ/51cmより高い障害物を取り除いてください。
- 32°F-104°F/0°C-40°Cの作動環境温度のみで動作する。
- 本製品を腐食性ガス、液体、ほこりの多い物体から遠ざけてください。
- 操作中に手、足、その他の体の部分を安全な位置に保ってください。アンチ衝突は、すべてのリセット中に自動的に有効にされていません。
- 機器の異常または非意図的な操作によって引き起こされた損傷と人身傷害に対していかなる保証または責任も負いません。
- 初回装着または機器通電後、手動リセットが必要です。



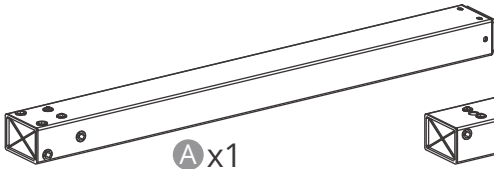

A x1

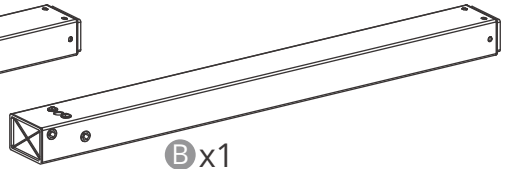

B x1

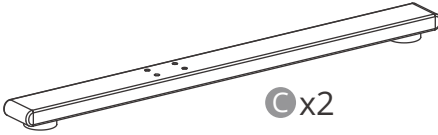

C x2

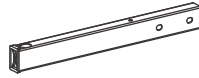

D x2



E x2

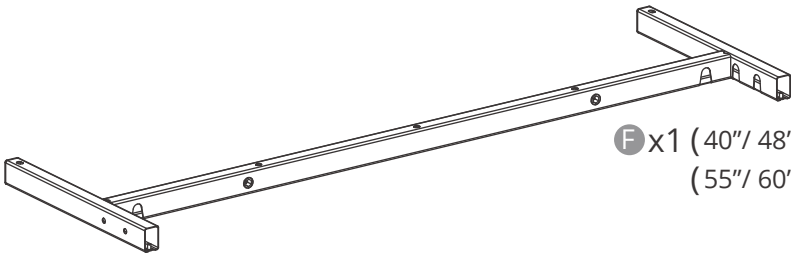

F x1 (40"/ 48": 935mm)
(55"/ 60": 1335mm)

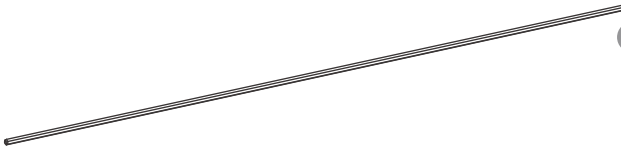

G x1 (40"/ 48": 885mm)
(55"/ 60": 1285mm)

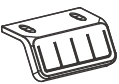

H x1



I x1

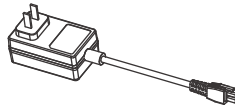

J x1

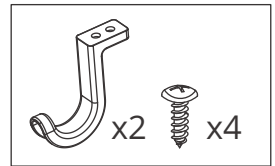

x2 x4

K

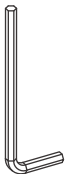

L x1



M x1

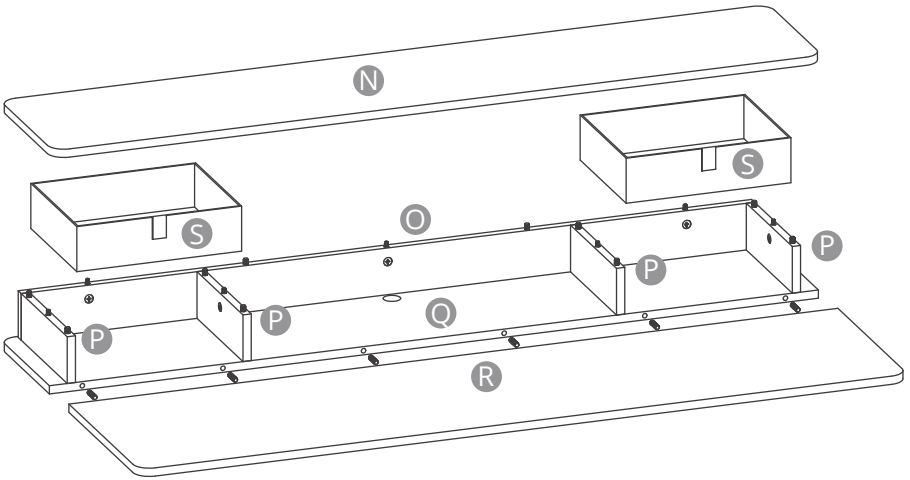

① x2 (40"
100cm)
x3 (48"
120cm)
x4 (55"/60"
140cm/152cm)



② x21 (40"
100cm)
x22 (48"/55"
120cm/140cm)
x23 (60"
152cm)



③ x15 (40"
100cm)
x17 (48"
120cm)
x20 (55"/60"
140cm/152cm)



④ x4

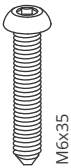

⑤ x14

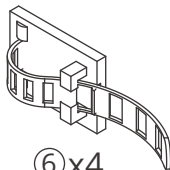

⑥ x4

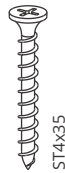

⑦ x11



⑧ x7



⑨ x7

Pre-installation Guide

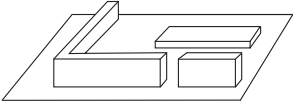

Assemble on a foam
to prevent scratch

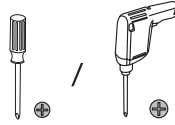

Phillips screwdriver or drill required
(not provided)

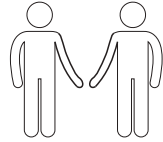

Get a friend for help

1

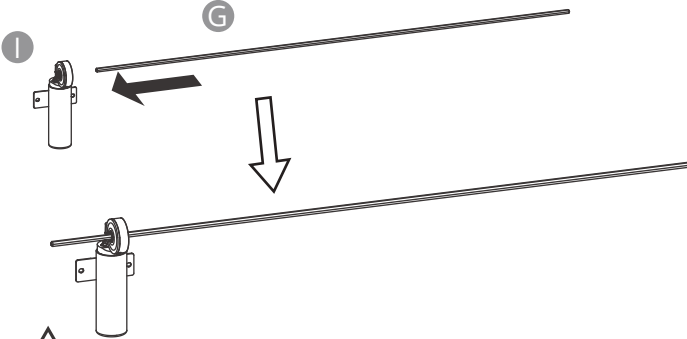

2



Please use a box to assist when installing the frame to achieve balance during installation.

Verwenden Sie eine Box, um beim Installieren des Rahmens eine Balance während der Installation zu erreichen.

Utilisez une boîte pour aider lors de l'installation du cadre afin d'obtenir un équilibre pendant l'installation.



Pay attention to the direction of motor installation.

Achten Sie auf die Richtung der Motorinstallation.

Faites attention à la direction de l'installation du moteur.

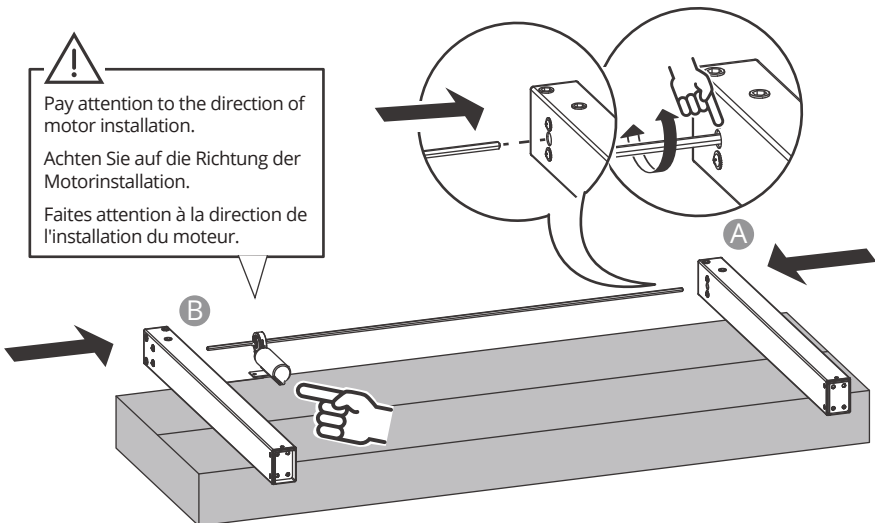

3

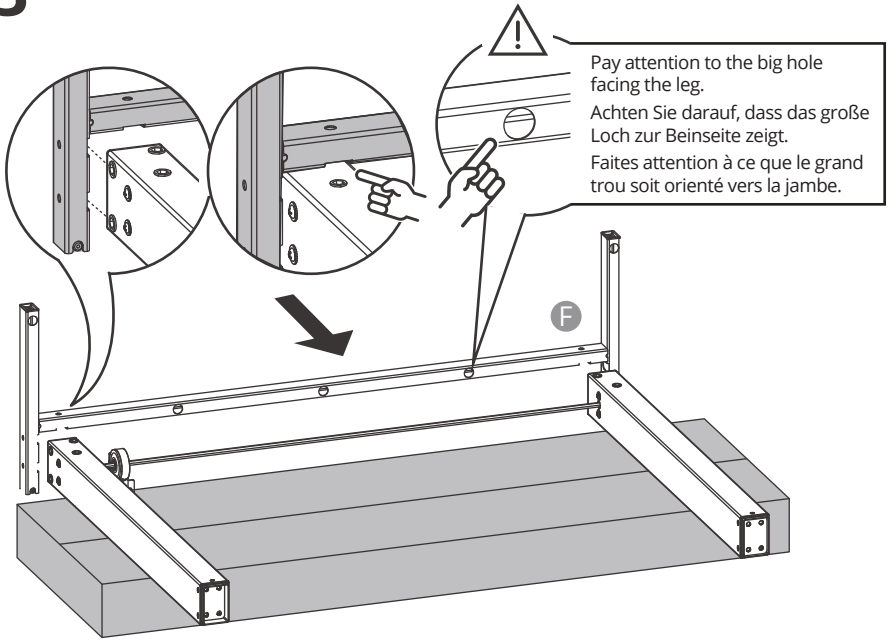

4

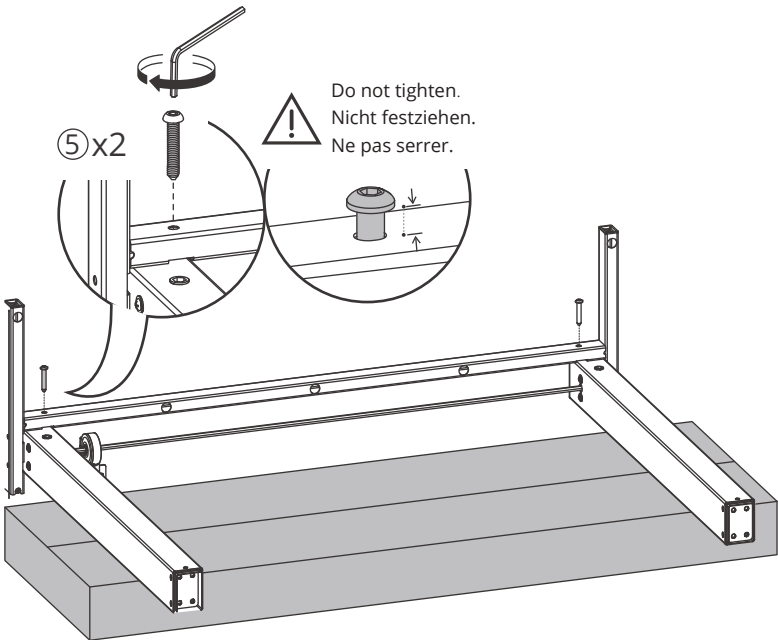

5

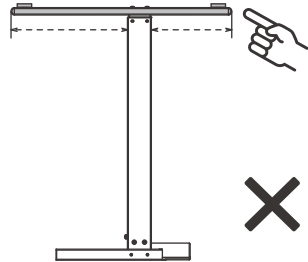
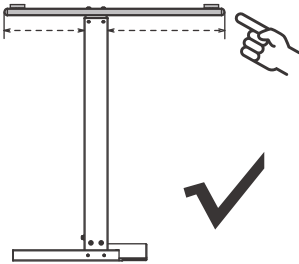
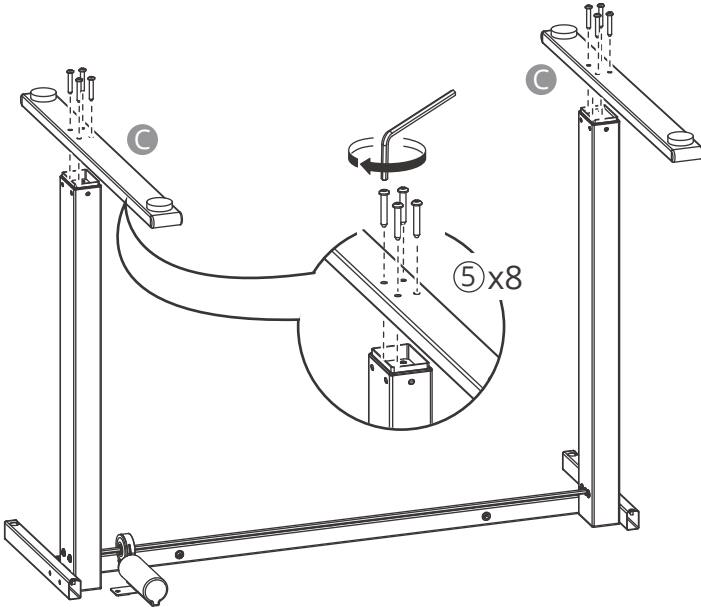

6

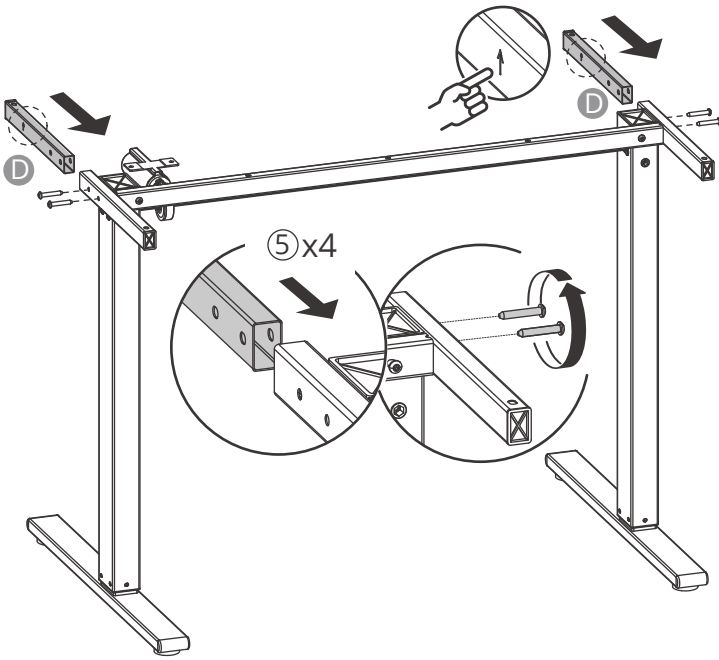

7

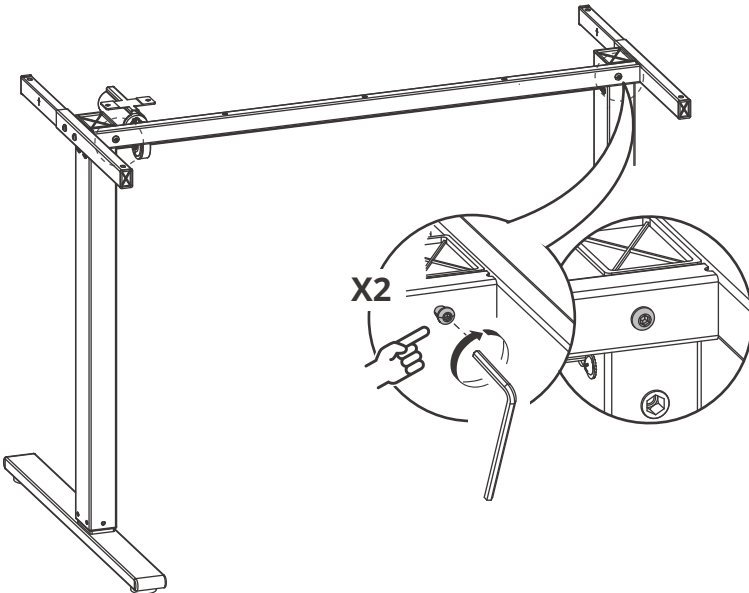

8

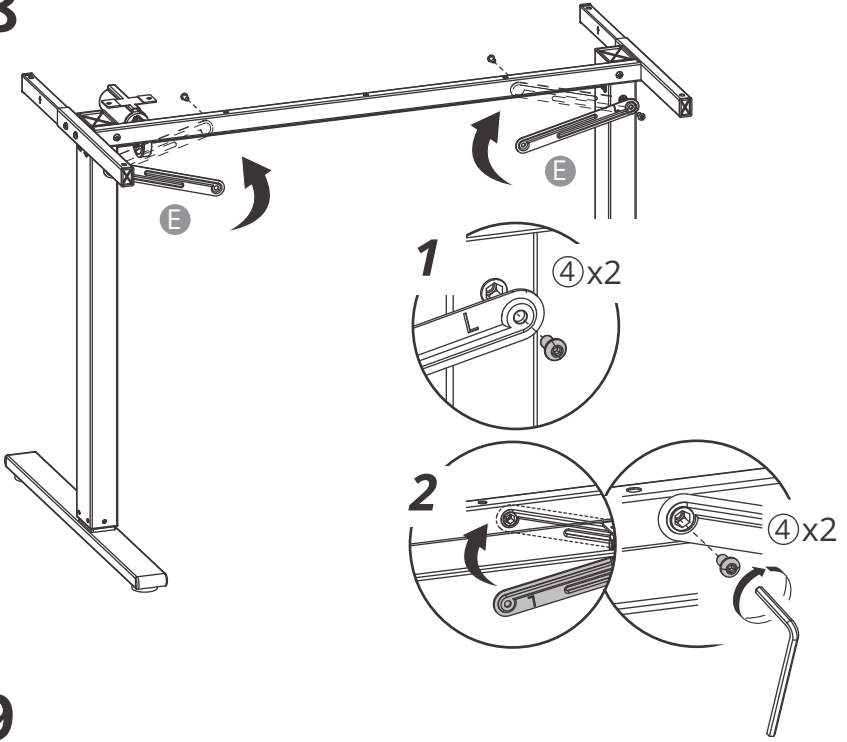

9

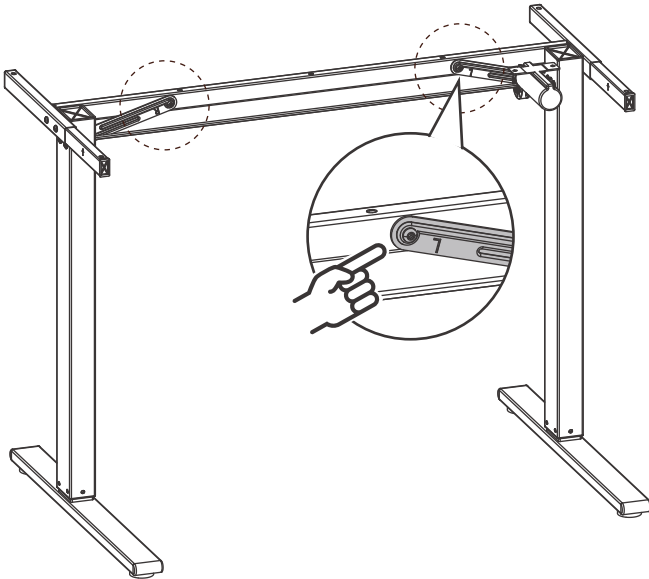

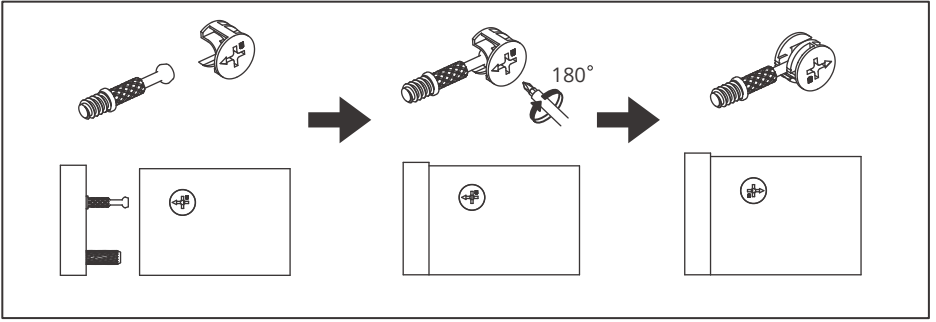

10

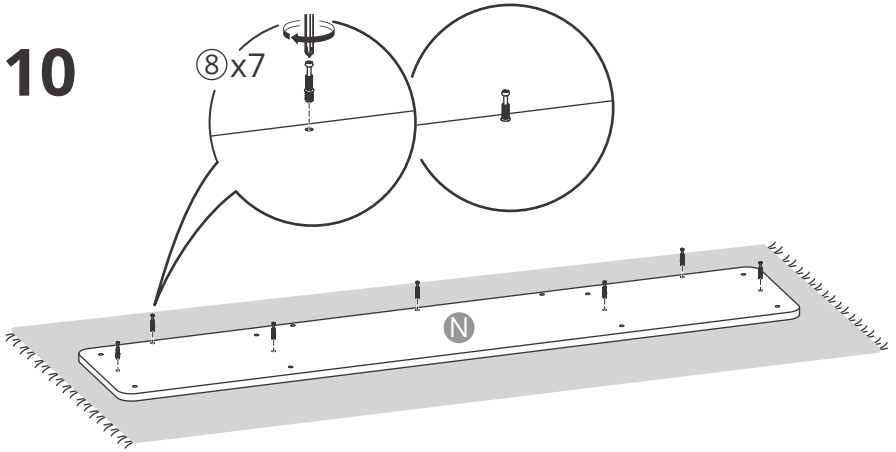

11

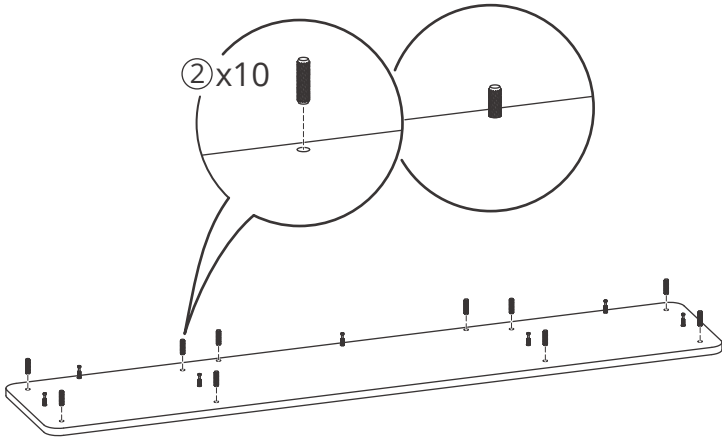

12

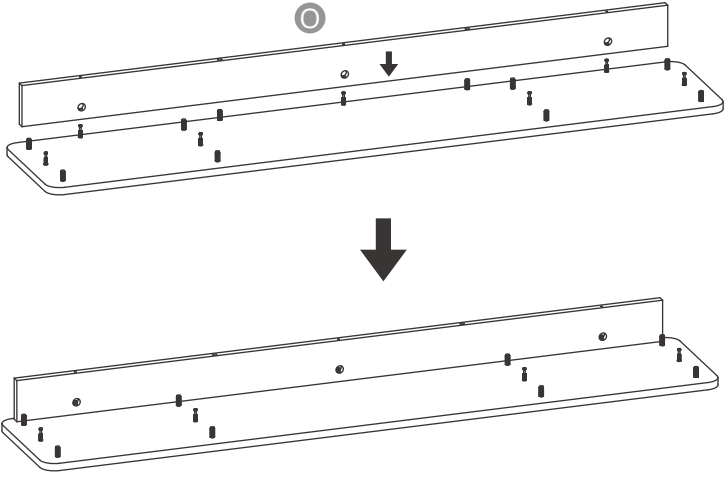

13

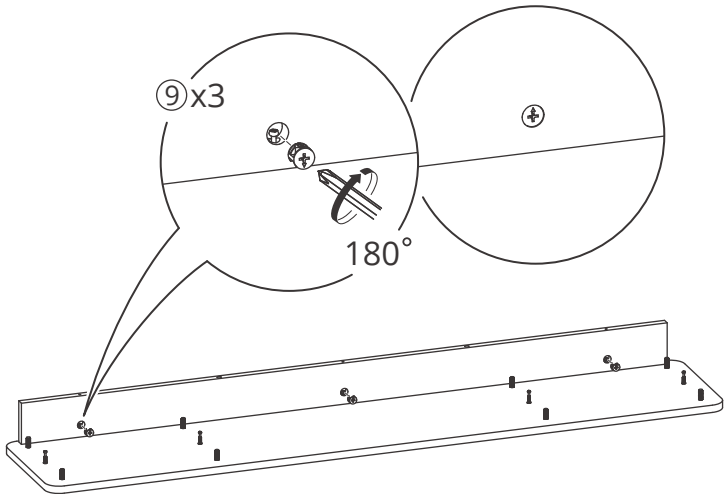

14

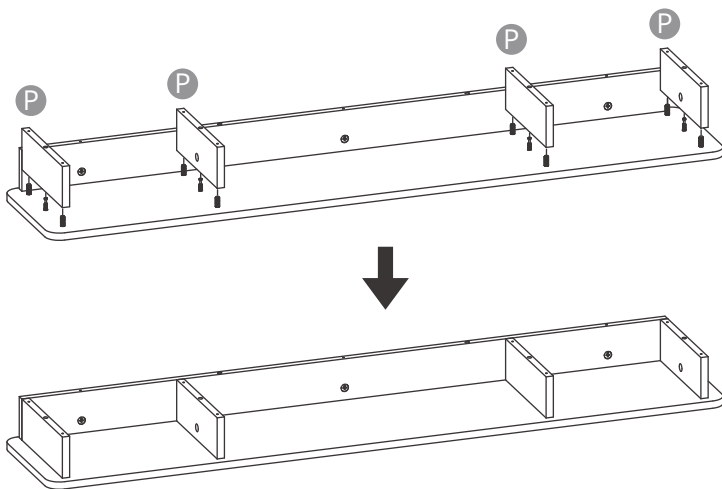

15

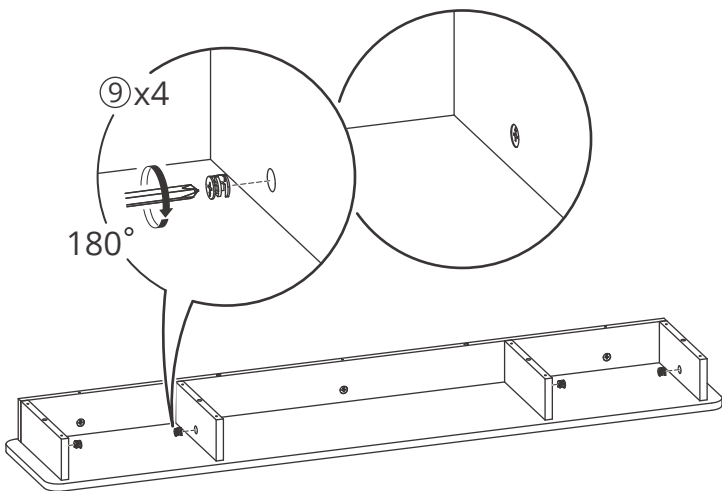

16

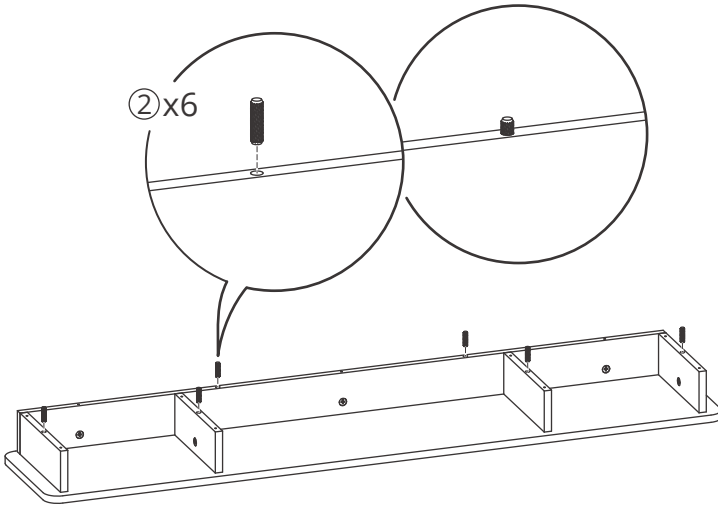

17

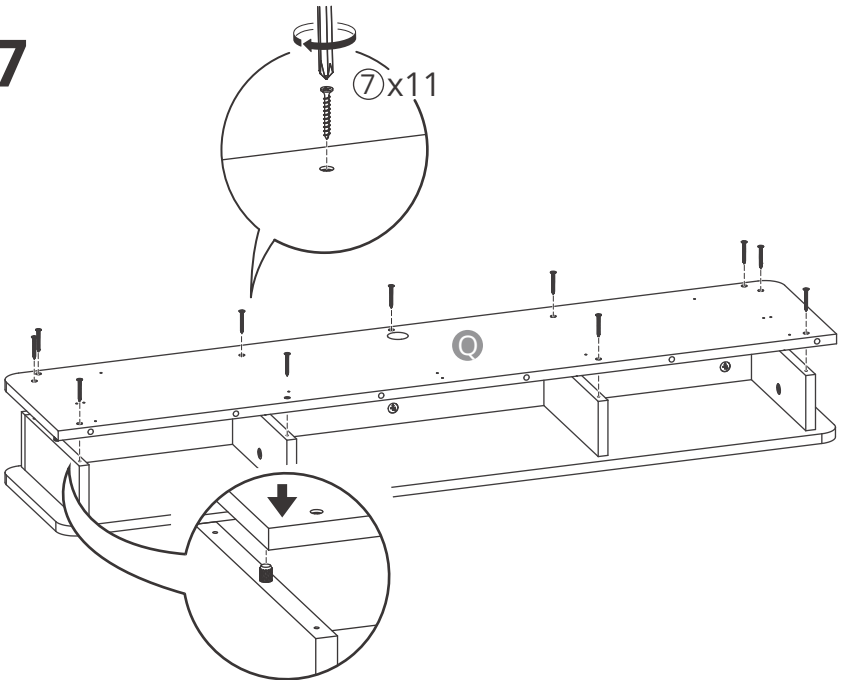

40"
(100cm)

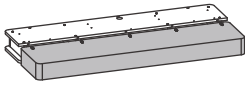

②x5

48"/55"
(120cm/140cm)

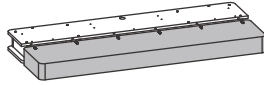

②x6

60"
(152cm)

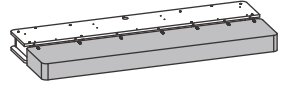

②x7

18

②x6

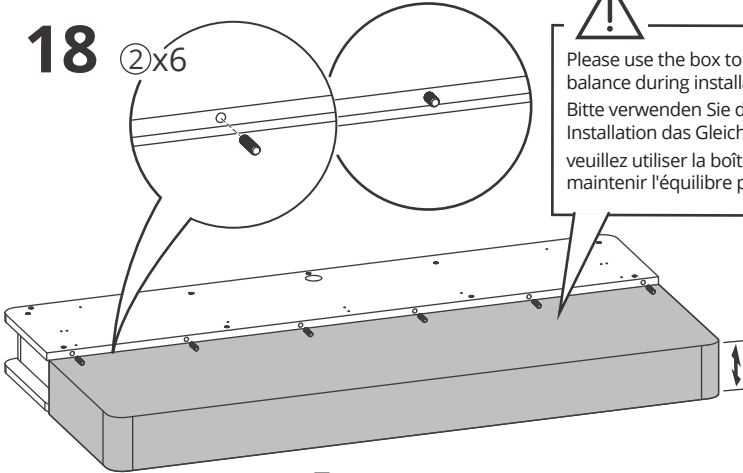

!
Please use the box to help maintain balance during installation.
Bitte verwenden Sie die Box, um bei der Installation das Gleichgewicht zu halten.
veuillez utiliser la boîte pour aider à maintenir l'équilibre pendant l'installation.

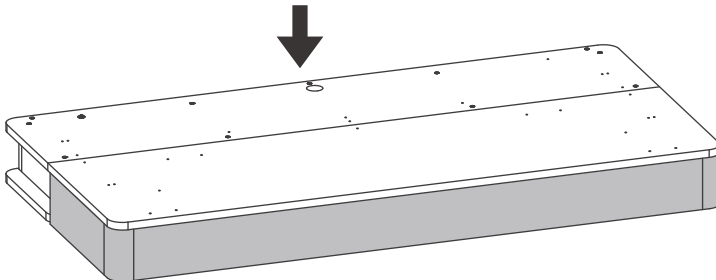
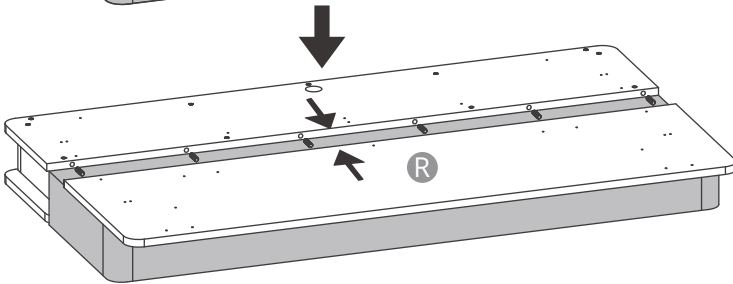

40"
(100cm)

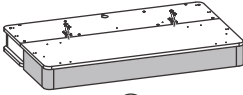

①x2
③x4

48"
(120cm)

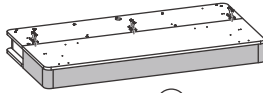

①x3
③x6

55" / 60"
(140cm/152cm)

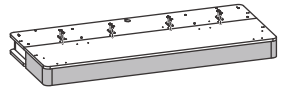

①x4
③x8

19

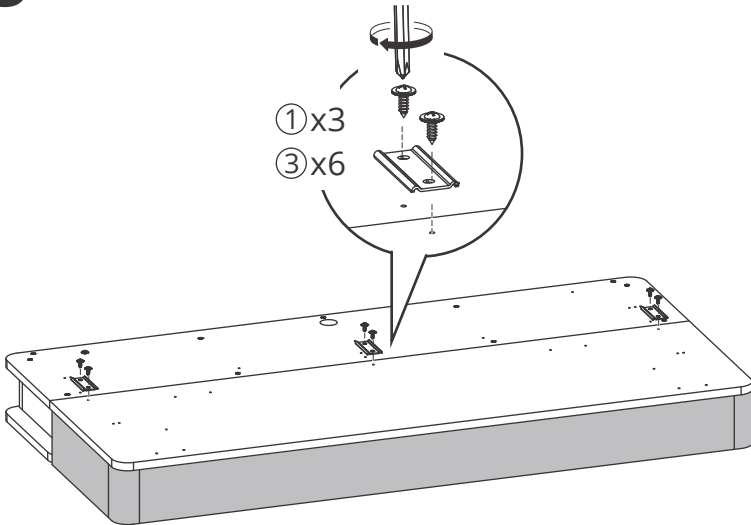

20

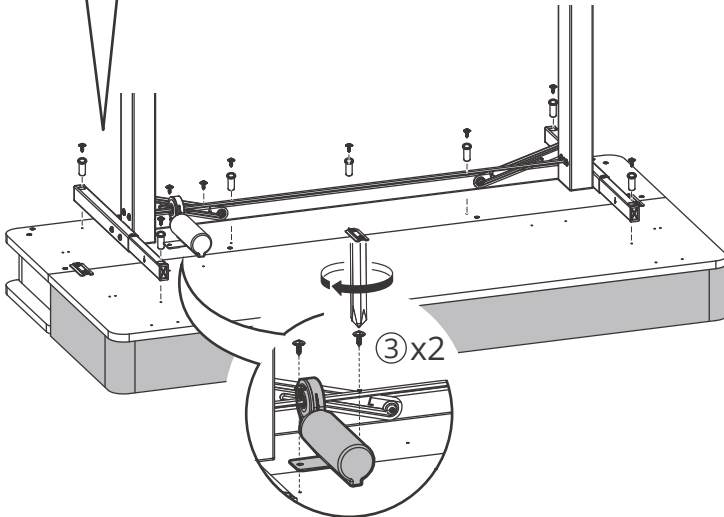
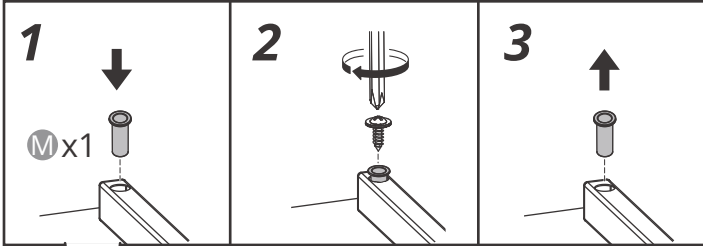
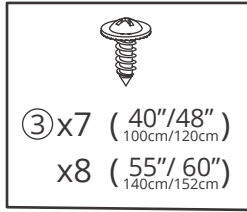

21

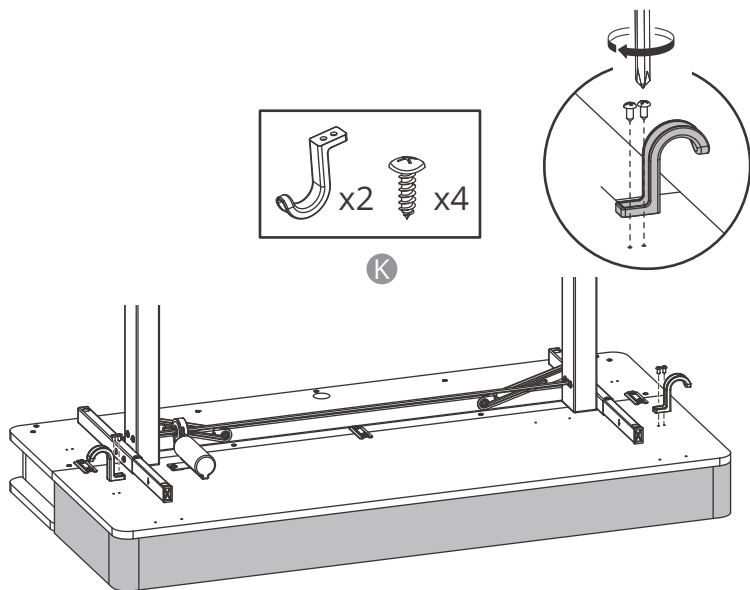

22

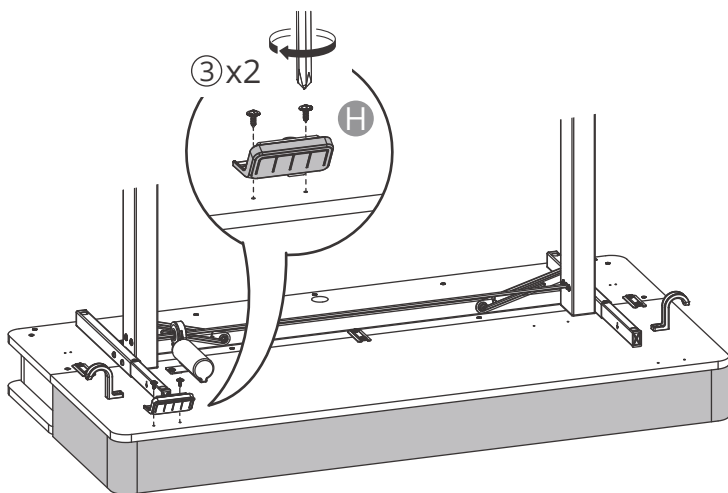

23

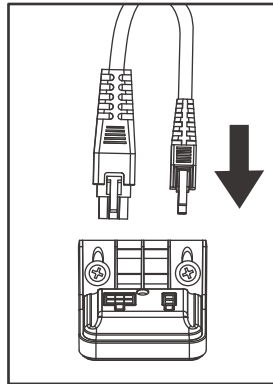
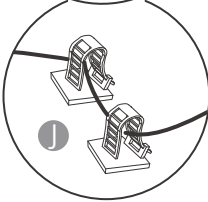
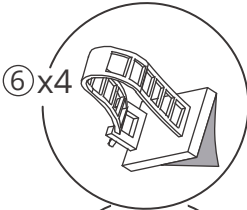
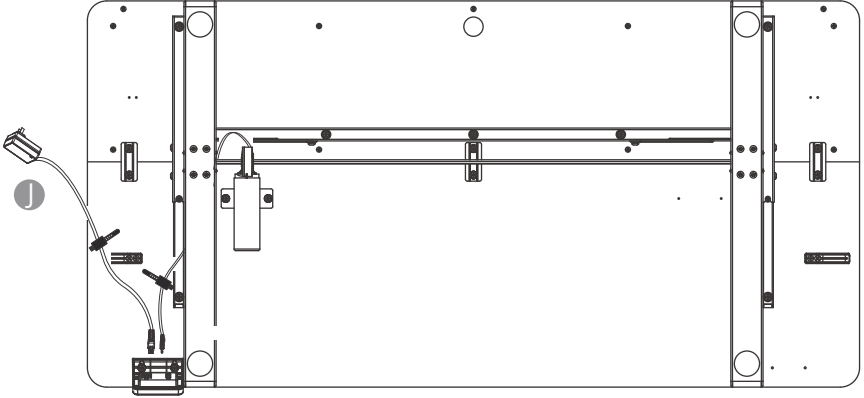

24

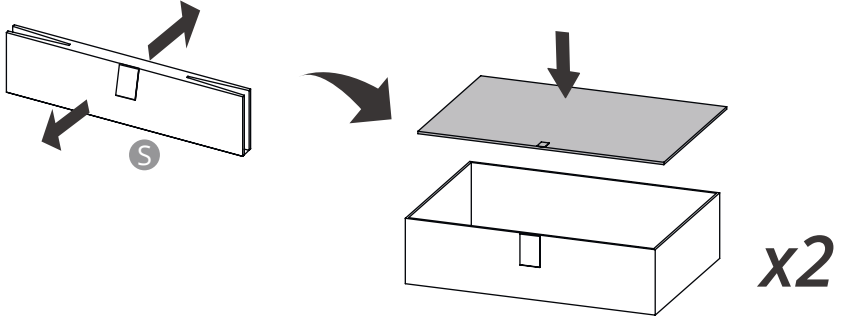

25

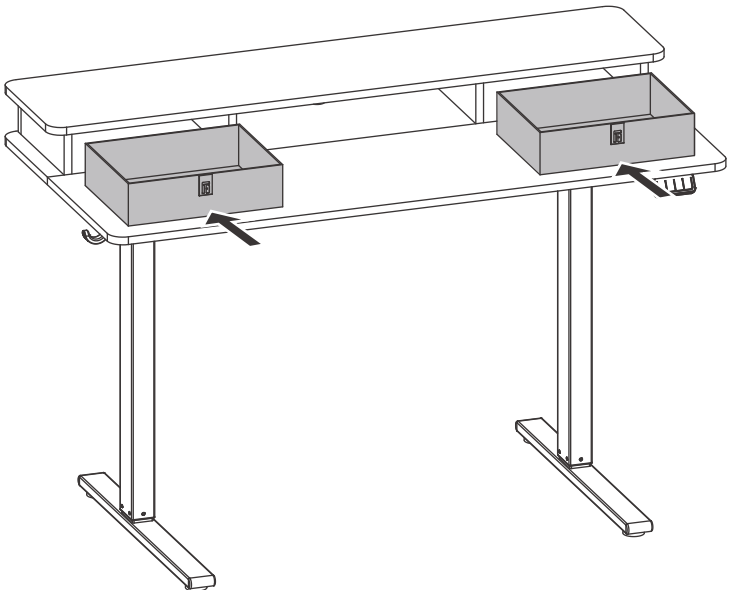

26

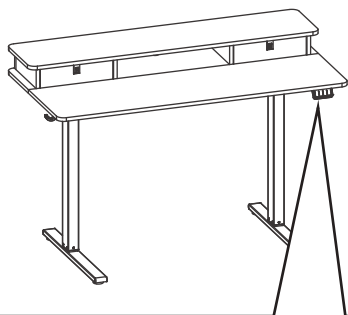

Reset

Please reset it first after installing the table. Press and hold the " ^ " and " v " button simultaneously for 5 seconds.

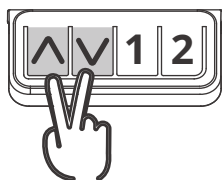

Zurücksetzen

Bitte setzen Sie es zuerst zurück, nachdem Sie den Tisch installiert haben. Drücken und halten Sie die Taste " ^ " und die Taste " v " gleichzeitig für 5 Sekunden.

Réinitialiser

Veuillez le réinitialiser d'abord après avoir installé la table. Appuyez et maintenez enfoncés les boutons " ^ " et " v " simultanément pendant 5 secondes.

Controller Instruction



English 20

Deutsch 20

Español 21

Français 21

Italiano 22

日本語 22