

# ASSEMBLY INSTRUCTIONS

## FULL BED







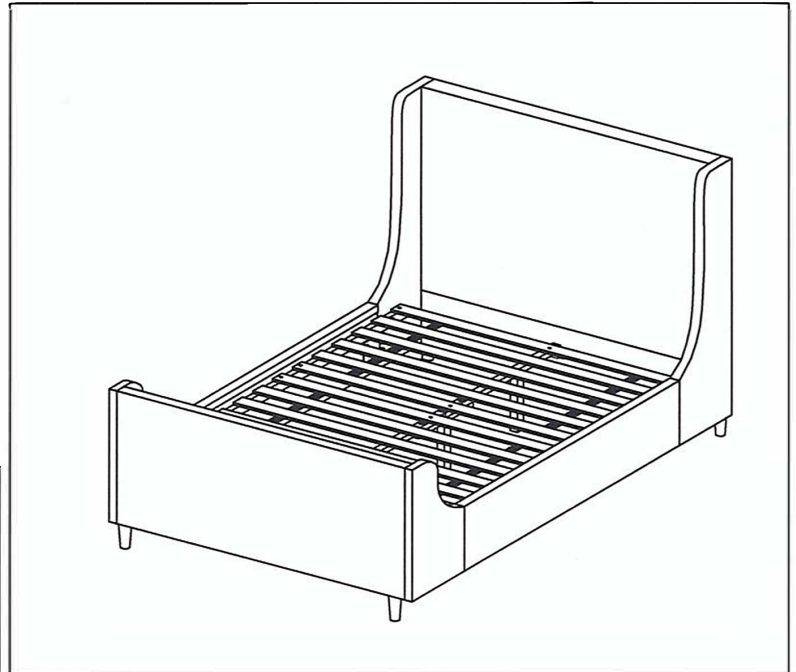

THANK YOU FOR PURCHASING THIS QUALITY PRODUCT. READ THESE INSTRUCTIONS CAREFULLY. SEE PARTS LIST AND HARDWARE LIST FOR GUIDANCE, BE SURE ALL PARTS ARE PRESENT PRIOR TO ASSEMBLY.

- CAUTIONS:
1. DO NOT FULLY TIGHTEN BOLTS UNTIL ALL BOLTS ARE IN PLACE AND READY FOR ASSEMBLY.
  2. DO NOT OVER TIGHTEN BOLTS TO AVOID CAUSING DAMAGE TO THE THREADS.
  3. KEEP ALL PARTS AND HARDWARE OUT TO REACH OF CHILDREN.

TOOLS NEEDED : SCREWDRIVER (NOT PROVIDED)

PARTS LIST		
ITEM	DESCRIPTION	QTY
A	HEADBOARD (1/3)	1 PC
B	HEADBOARD WING (L&R) (3/3)	2 PCS
C	FOOTBOARD (3/3)	1 PC
D	SIDE RAIL (2/3)	2 PCS
E	CENTER SUPPORT (3/3)	2 PCS
F	CENTER CROSS BAR (3/3)	1 PC
G	CENTER SUPPORT LEG (LONG) (3/3)	2 PCS
H	CENTER SUPPORT LEG (SHORT) (3/3)	1 PC
I	BED LEG (3/3)	4 PCS
J	SLATS (6 PCS) (3/3)	2 SET



HARDWARE LIST		
ITEM	DESCRIPTION	QTY
1	JCBB BOLT M8 x 16mm (3/3) 	8 PCS
2	JCBB BOLT M8 x 35mm (3/3) 	6 PCS
3	JCBB BOLT M8 x 45mm (3/3) 	6 PCS
4	JCBC BOLT M6 x 45mm (3/3) 	5 PCS
5	FLAT WASHER M8 x 18mm (3/3) 	20 PCS
6	SPRING WASHER M8 x 13mm (3/3) 	20 PCS
7	CSK SCREW M4 x 38mm (3/3) 	12 PCS
8	ALLEN KEY M4 (3/3) 	1 PC
9	ALLEN KEY M5 (3/3) 	1 PC

### STEP 1

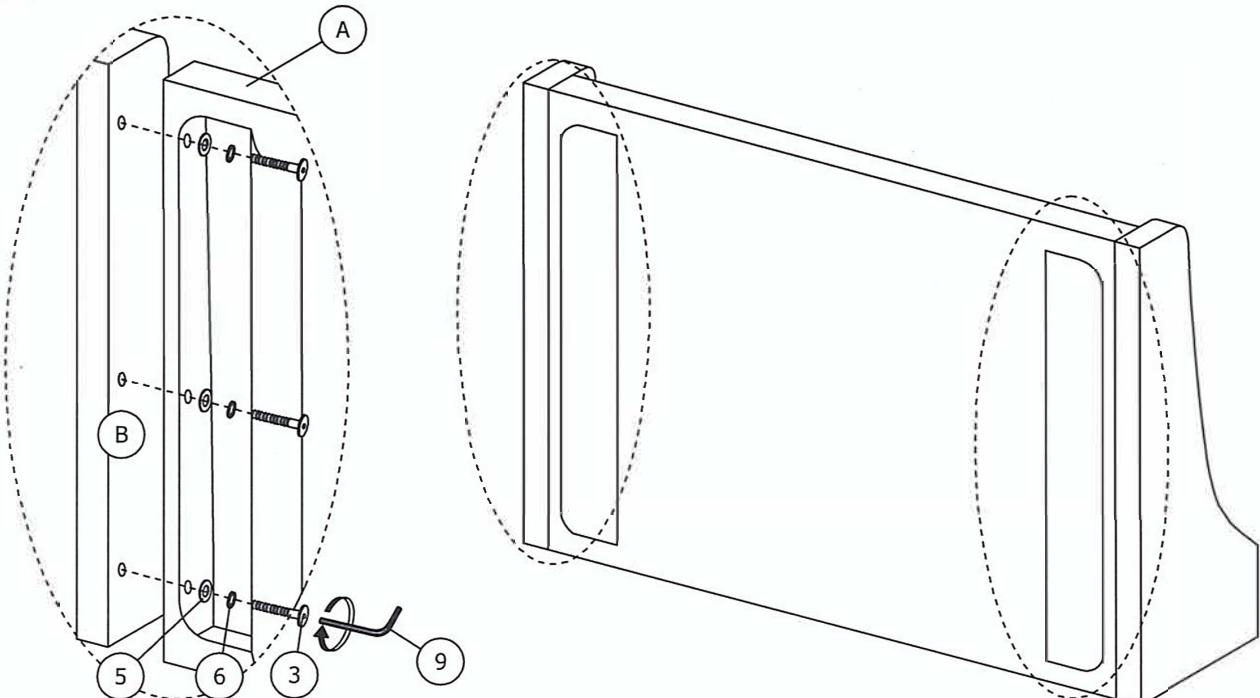

**STEP 2**

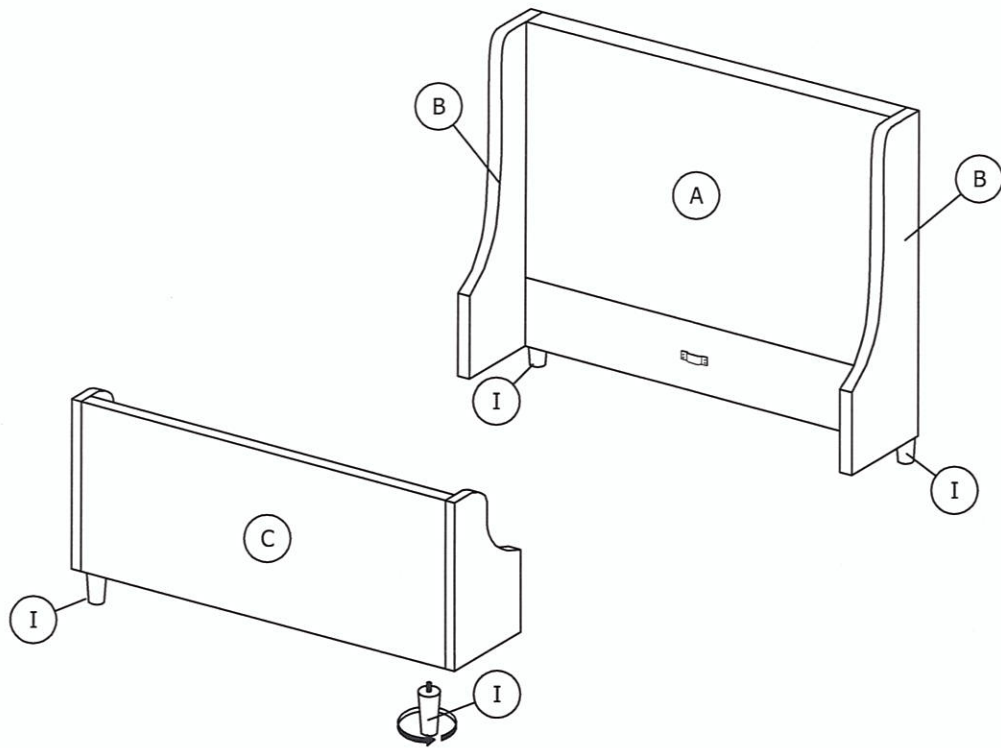

**STEP 3**

STEP A : DO NOT TIGHTEN THE BOLT(1).

STEP B : TIGHTEN THEM AFTER ASSEMBLY THE SIDE RAILS (D).

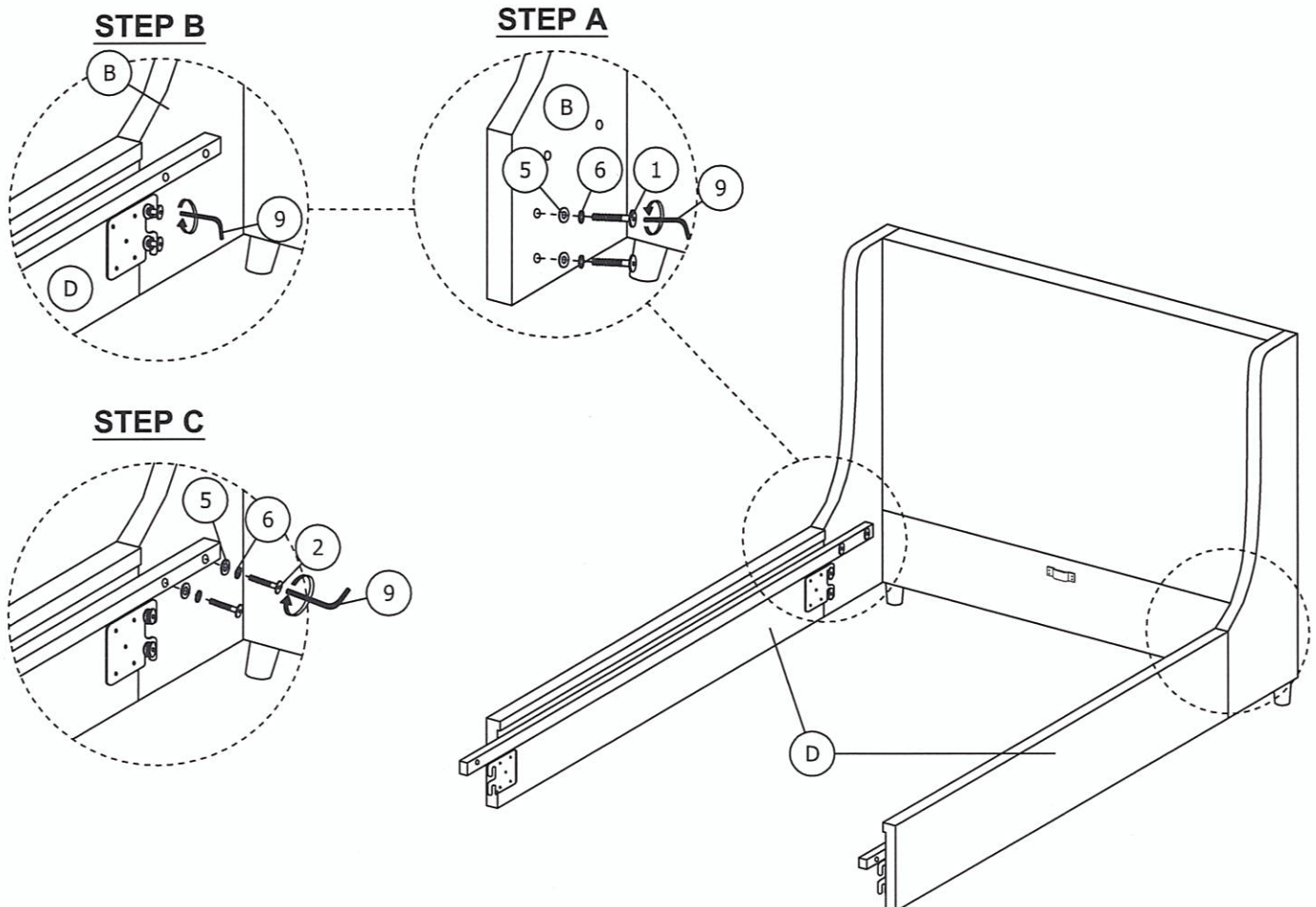

**STEP 4**

STEP A : DO NOT TIGHTEN THE BOLT(1).

STEP B : TIGHTEN THEM AFTER ASSEMBLY THE SIDE RAILS (D).

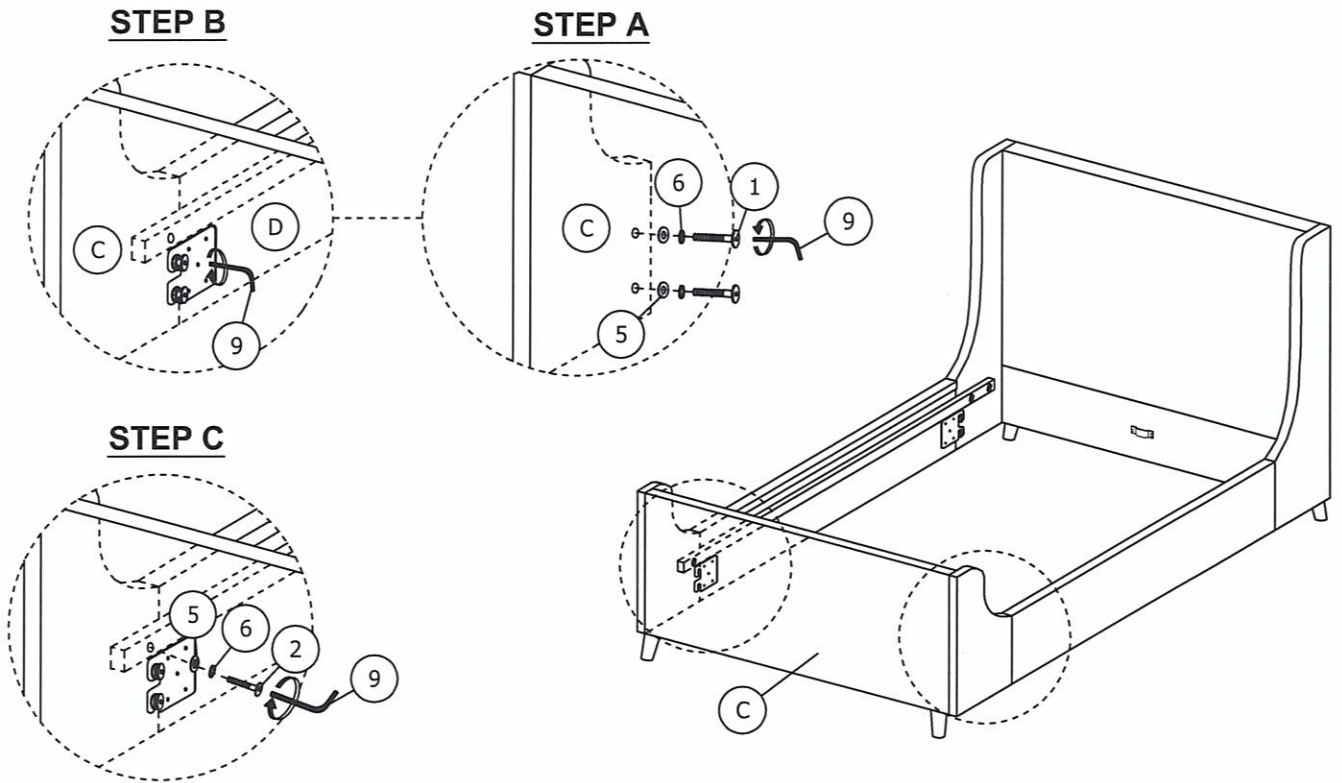

**STEP 5**

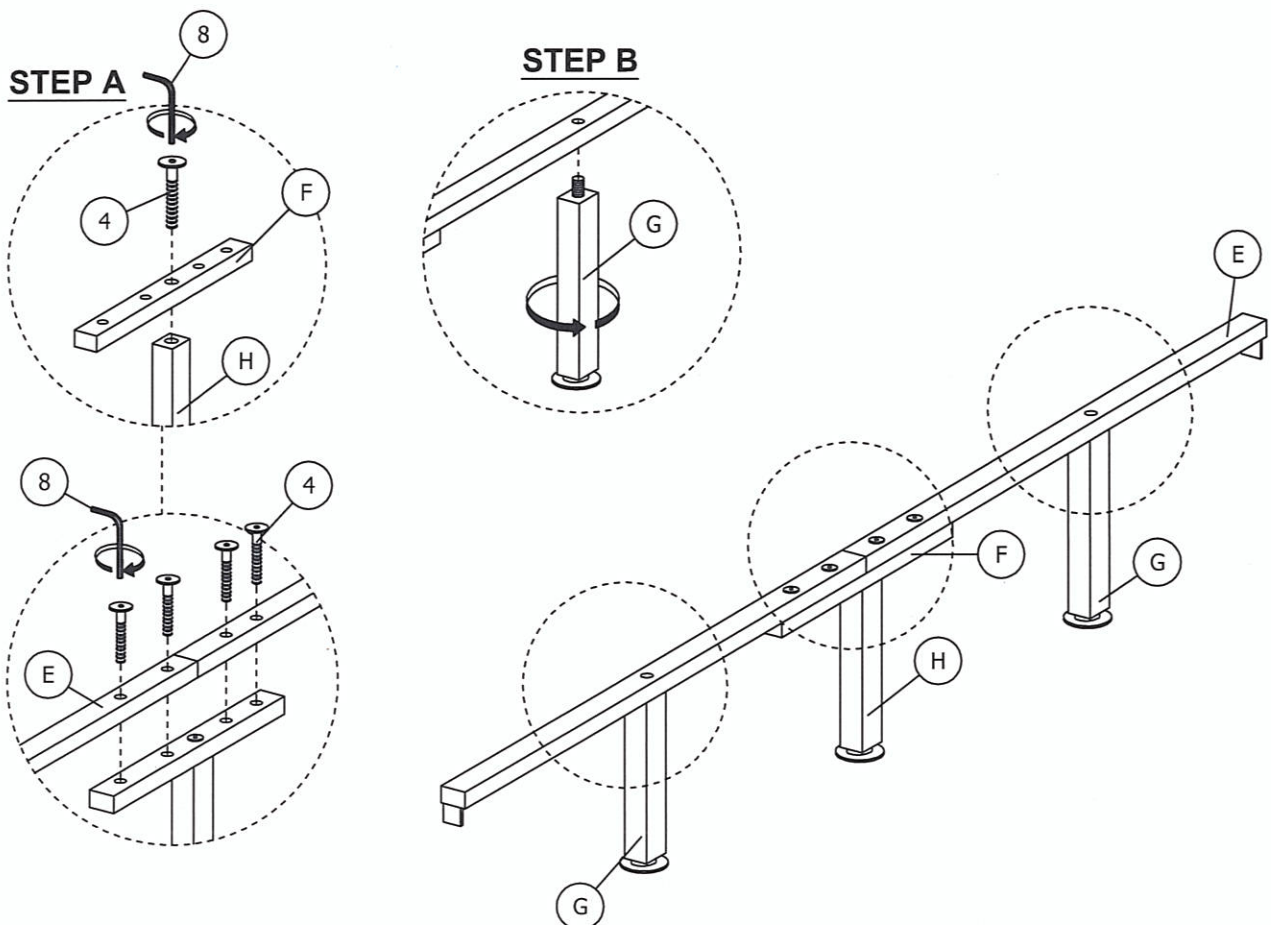

STEP 6

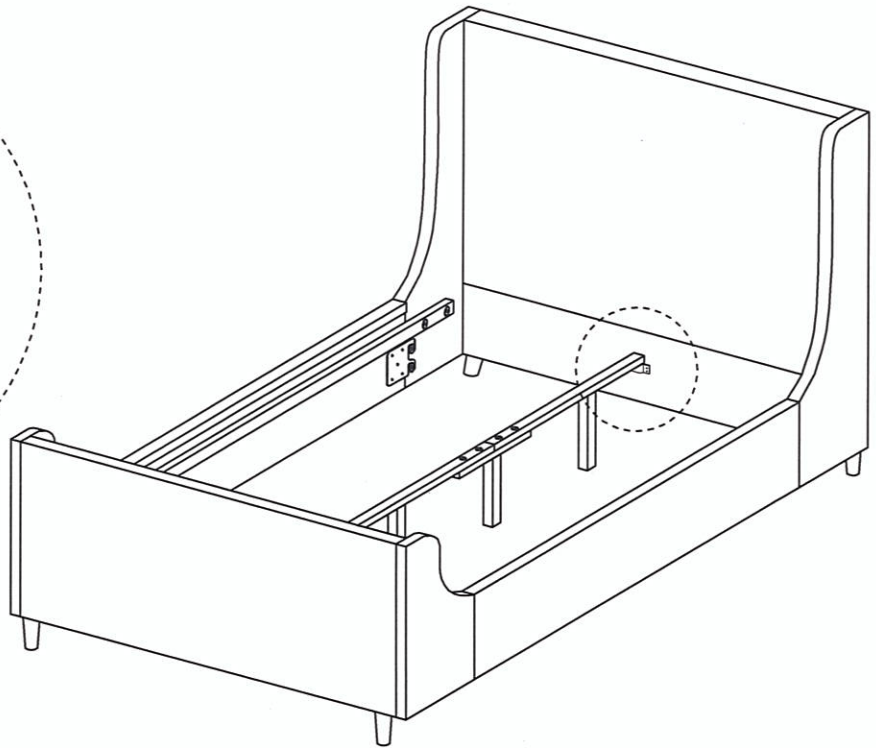
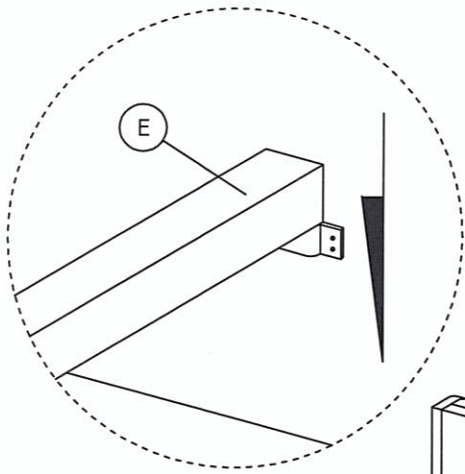

STEP 7

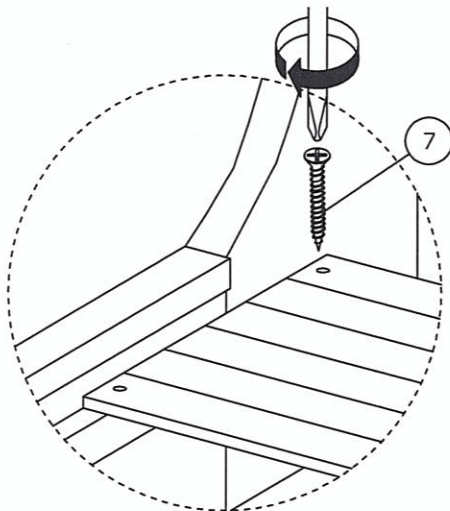

STEP FOR ASSEMBLY SLATS (J).

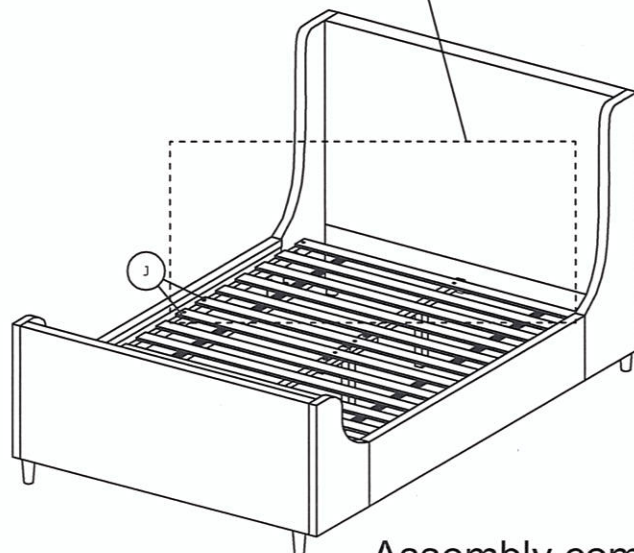
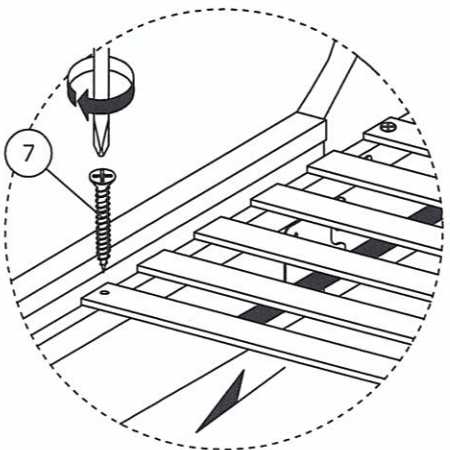
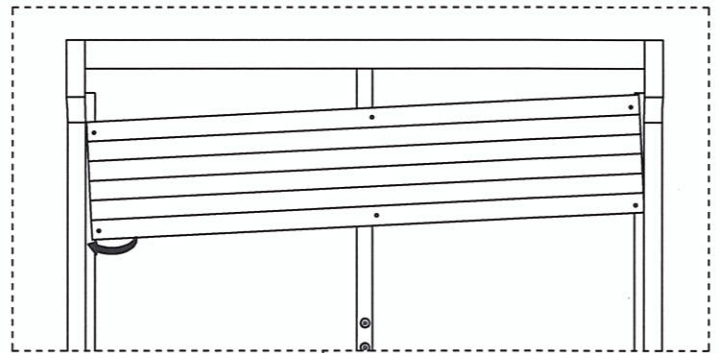

\* DO NOT DRAG BED AS SUPPORT LEGS MAY DISLODGE OR BREAK OFF.