

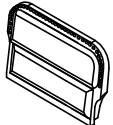









# ASSEMBLY INSTRUCTIONS

## CHAIR

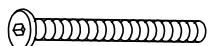
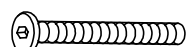
NO.	PARTS LIST	QTY	DESCRIPTION
A		1	BACK REST
B		1	LSF EAR
C		1	RSF EAR
D		1	SEAT
E	 60*55*68mm	2	BACK WOODEN LEGS
F	 ø110*105mm	2	FRONT WOODEN LEGS

NO.	HARDWARE LIST	QTY	DESCRIPTION
G	 M8*75MM	2	BOLT
H	 M8*60MM	2	BOLT
I	 M8	2	FLAT WASHER
J	 M8	2	SPRING WASHER
K	 M5*100*38MM	1	ALLEN KEY

# ASSEMBLY INSTRUCTIONS

## CHAIR

CAUTION: PLEASE READ ALL INSTRUCTIONS CAREFULLY BEFORE STARTING ASSEMBLY PROCESS. IT IS RECOMMENDED TO USE TWO PEOPLE WHEN ASSEMBLING AND REMOVING THE INSIDE BACKS TO AND FROM THE BASE OF THE FURNITURE.

STEP 1: Side LSF & RSF ears up to lock

STEP 2: Plug back into the seat base slot and lock tight with bolts and screw driver

STEP 3: Setup front and back legs

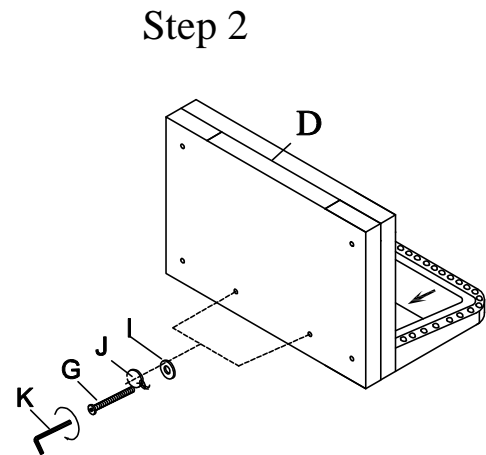
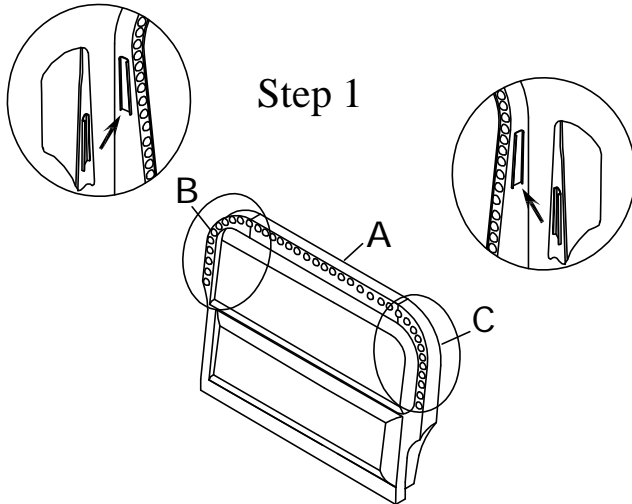

Step 3

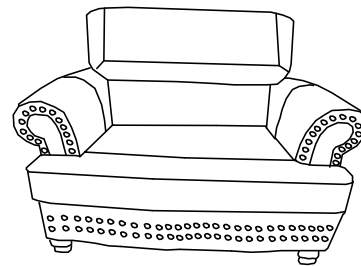
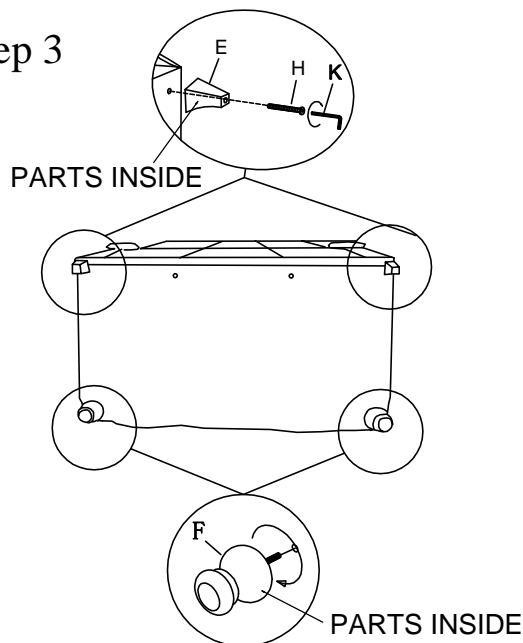

### CARE INSTRUCTION FOR LEATHER GEL FURNITURE

In order to maintain the original appearance of your leather gel furniture, please follow below simple care procedures .  
°Avoid exposing furniture directly to sunlight or heating and air conditioning outlets. Exposure to sunlight or heating and air conditioning outlets will fade/damage leather gel.  
°Wipe gently with a damp soft cloth to remove dust, dirt and any grime build up.