

**ASSEMBLY INSTRUCTION**

ADULT ASSEMBLY REQUIRED

**THE PRODUCT MAY RECOMMENDED  
ASSEMBLING BY MORE THAN ONE  
PERSON.**

**PLEASE ASK FOR ASSISTANCE AT YOUR  
CONVENIENCE BEFORE ASSEMBLING.**

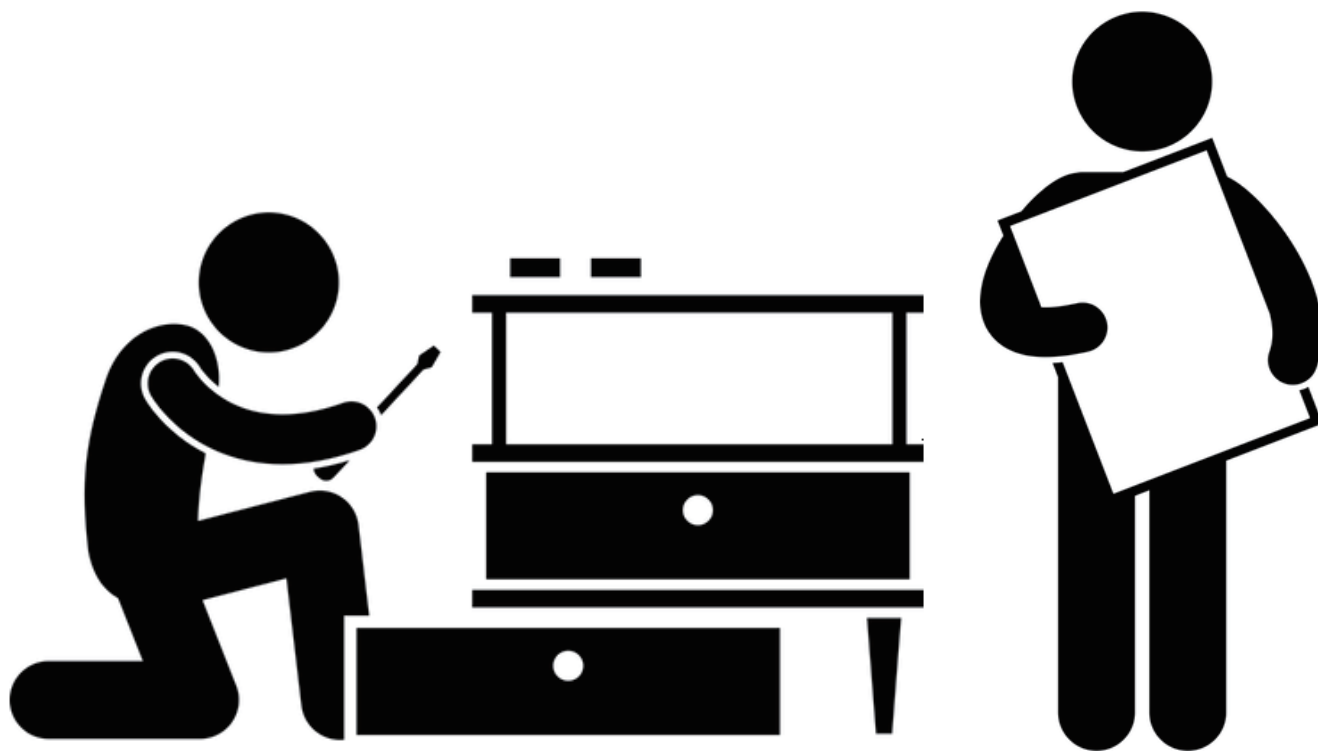

# Before You Start

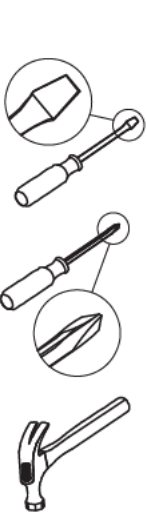

- Read through each step carefully and follow the proper order
- Separate and count all your parts and hardware
- Give yourself enough room for the assembly process
- Have the following tools: Flat Head Screwdriver, #2 Phillips Head Screwdriver and Hammer
- Caution: If using a power drill or power screwdriver for screwing, please be aware to slow down and stop when screw is tight. Failure to do so may result in stripping the screw.

# Cam Lock Fastening System

This Cam Lock Fastening System will be used throughout the assembly process.

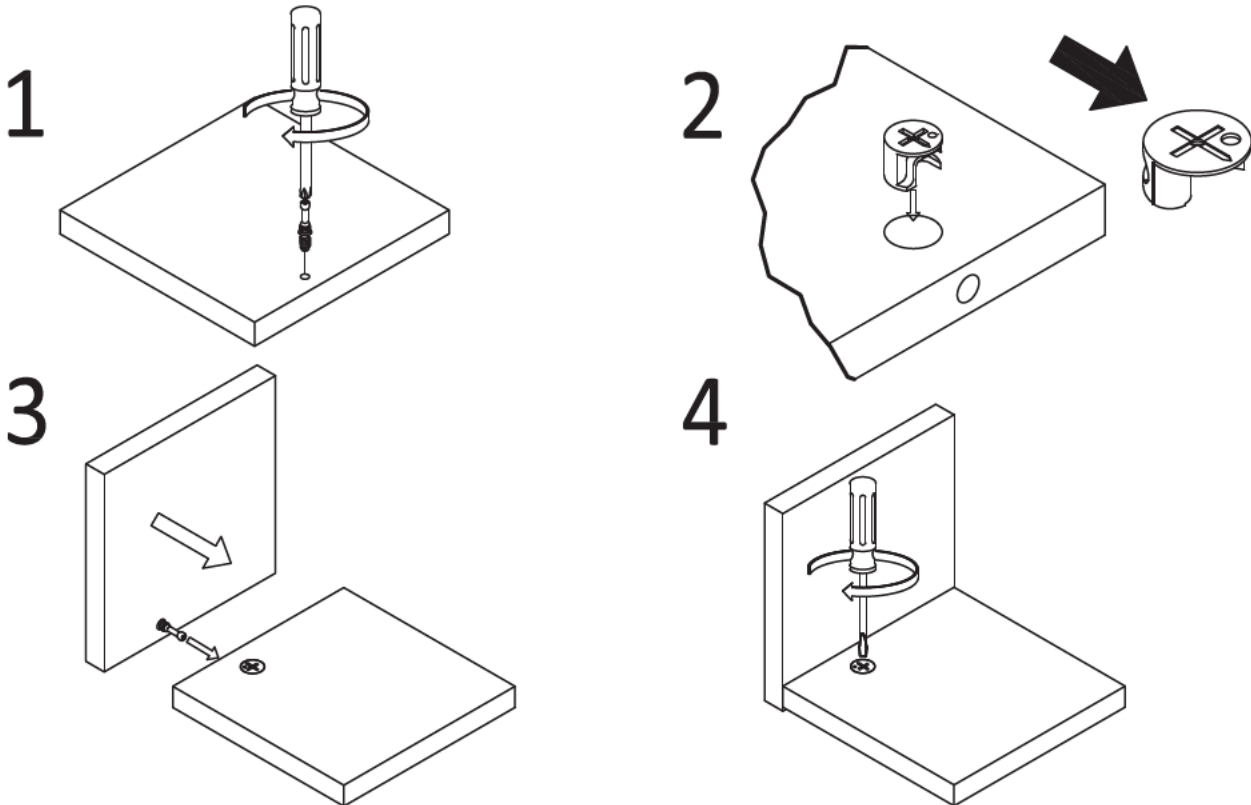

# Parts Identification

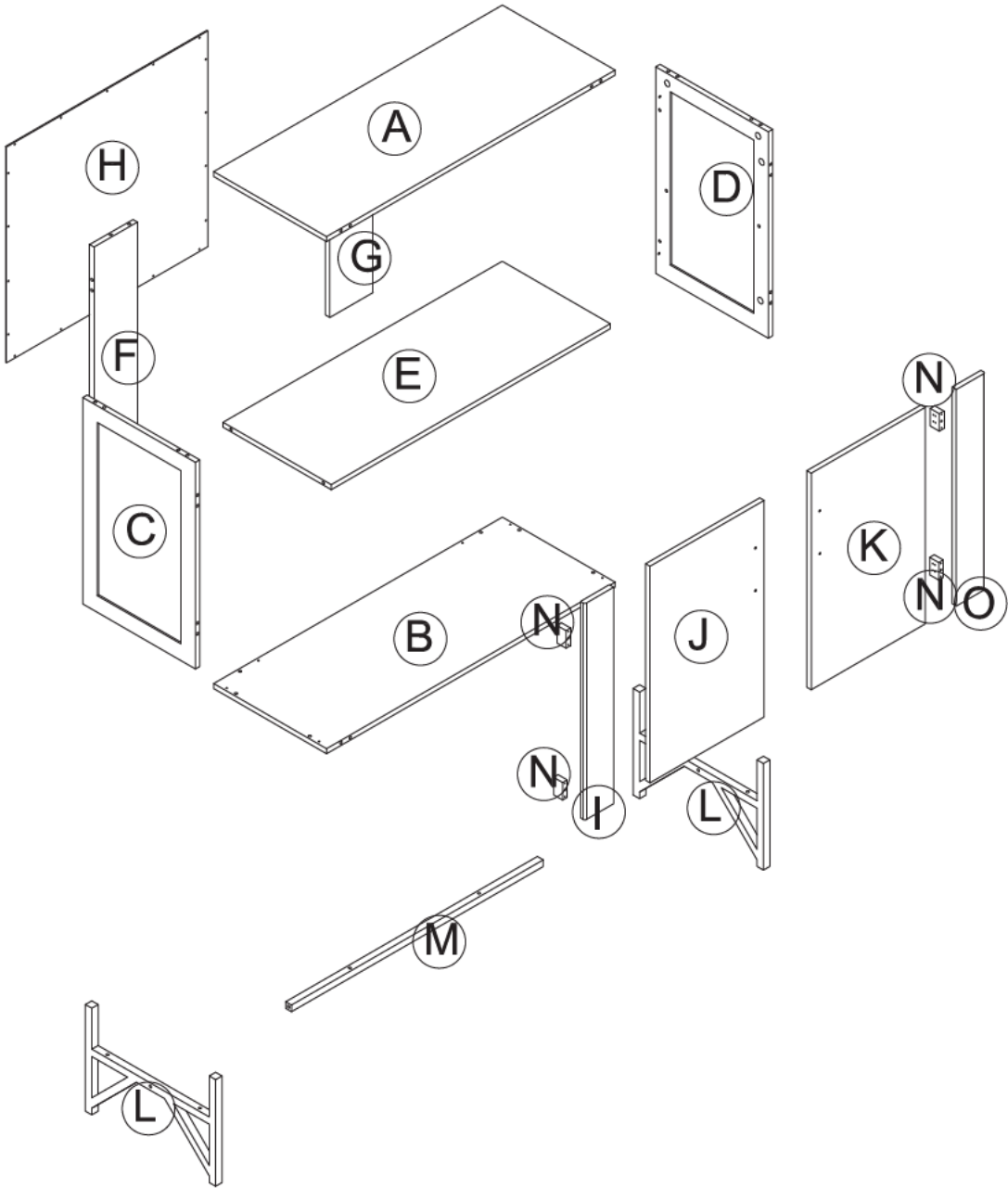

# Parts Identification

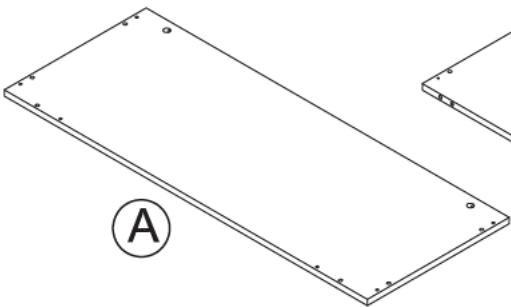

(A)

TOP

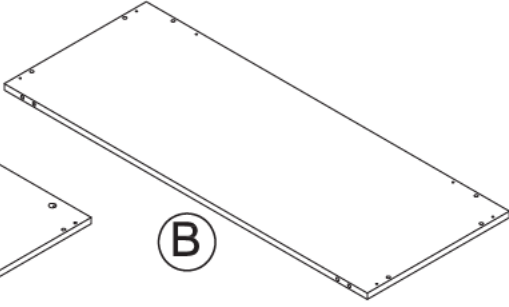

(B)

BOTTOM

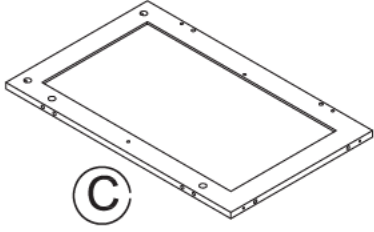

(C)

LEFT

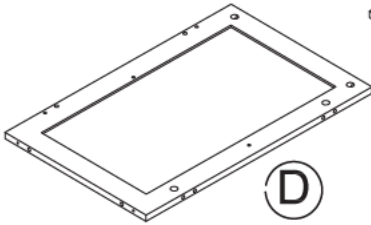

(D)

RIGHT

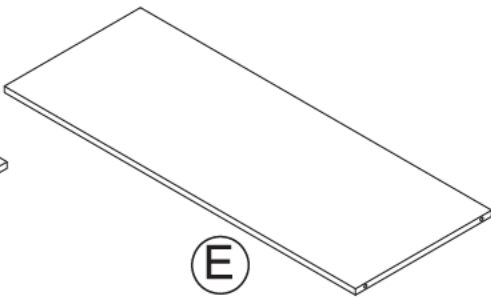

(E)

SHELF

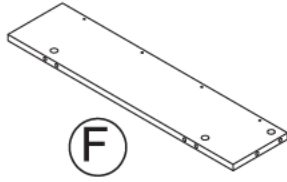

(F)

BACK LEFT DECOR

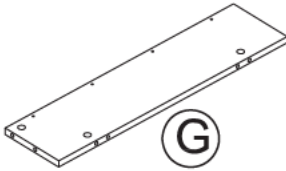

(G)

BACK RIGHT DECOR

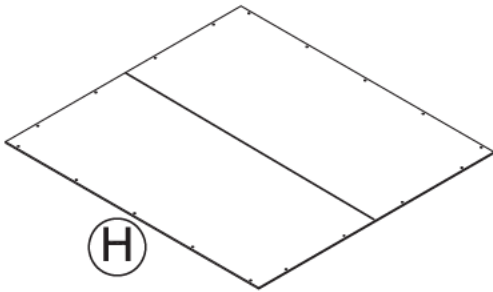

(H)

BACK PANEL

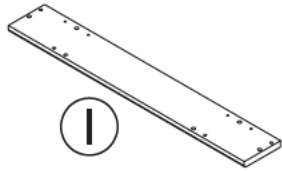

(I)

FRONT LEFT DECOR

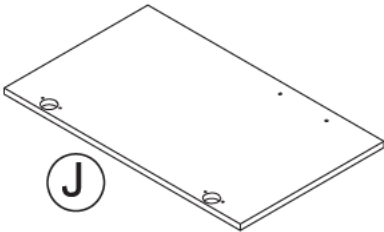

(J)

LEFT DOOR

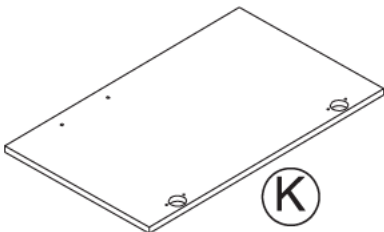

(K)

RIGHT DOOR

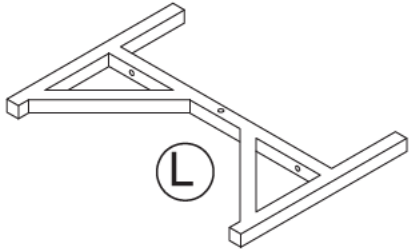

(L)

RIGHT AND LEFT END x 2

# Parts Identification

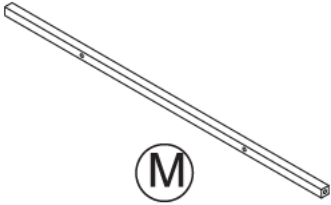

LOWER SUPPORT

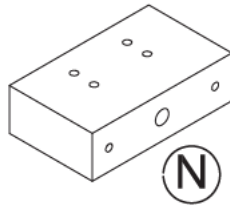

INNER SIDE SUPPORT x 4

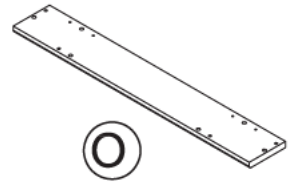

FRONT RIGHT DECOR

# Hardware Identification

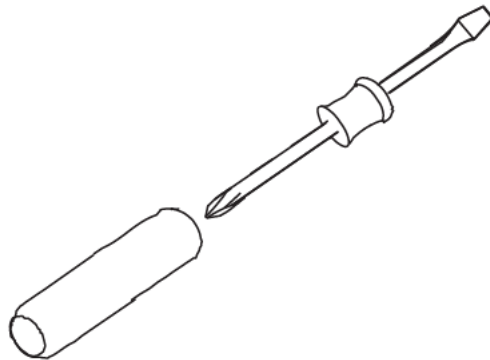

**DOUBLE-HEADED SCREWDRIVER:**  
THIS TOOL ALLOWS YOU TO USE DIFFERENT HEAD FOR DIFFERENT  
TYPE OF SCREWS BY SWITCH THE YELLOW HANDLE

# Hardware Identification

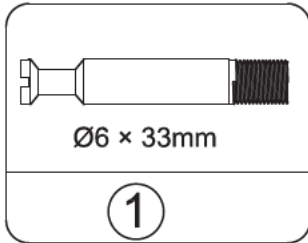

1

CAM BOLT  
QTY: 22+1 spare

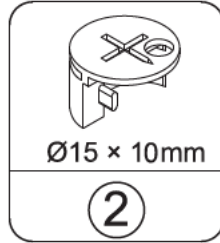

2

CAM LOCK  
QTY: 22+1 spare

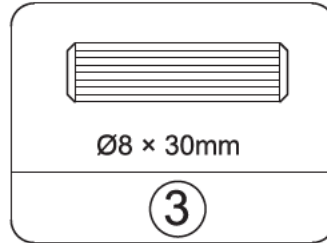

3

WOOD DOWEL  
QTY: 28+1 spare

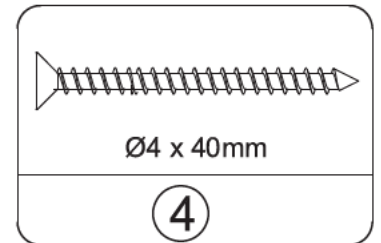

4

SCREW  
QTY: 6+1 spare

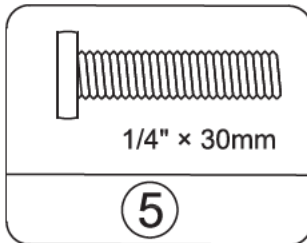

5

BOLT  
QTY: 6+1 spare

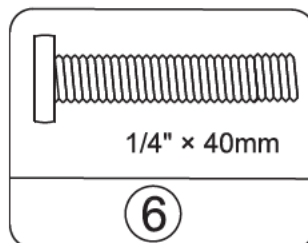

6

BOLT  
QTY: 10+1 spare

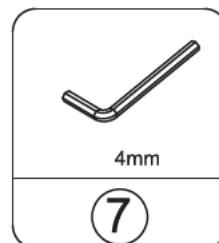

7

HEX KEY  
QTY: 1

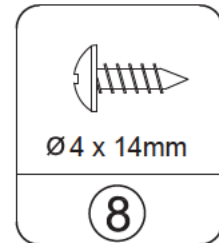

8

SCREW  
QTY: 18+1 spare

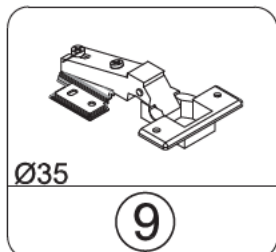

9

EUROPE HINGE  
QTY: 4

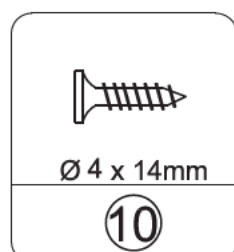

10

SCREW  
QTY: 24+1 spare

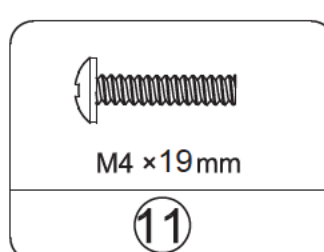

11

BOLT  
QTY: 4+1 spare

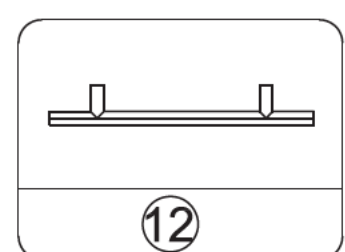

12

HANDLE  
QTY: 2

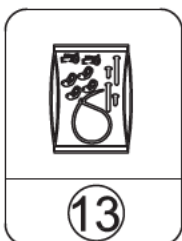

13

TIPPING RESTRAINT  
HARDWARE KIT  
QTY: 1

# Step 1

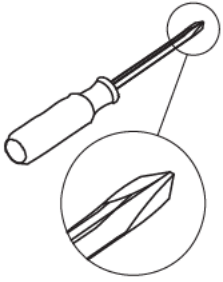

Assemble screws  
(part#1) vertically

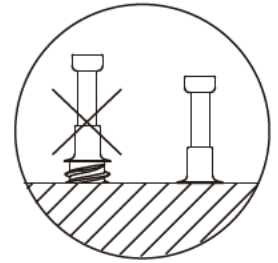

Make sure screws are  
lock up evenly on board

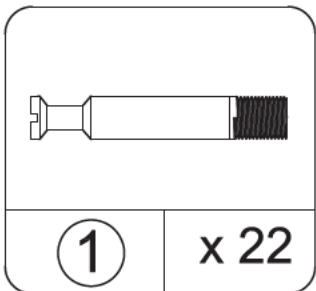
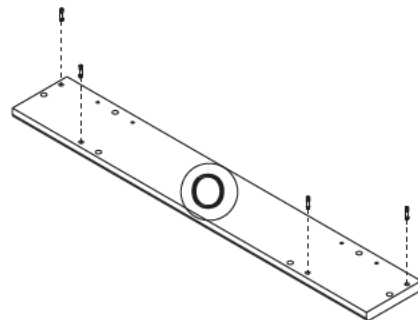
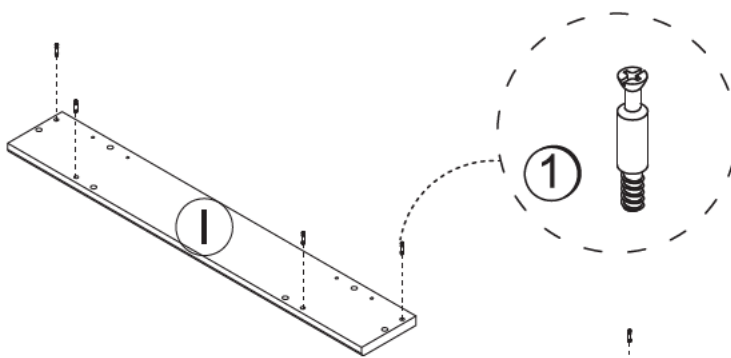
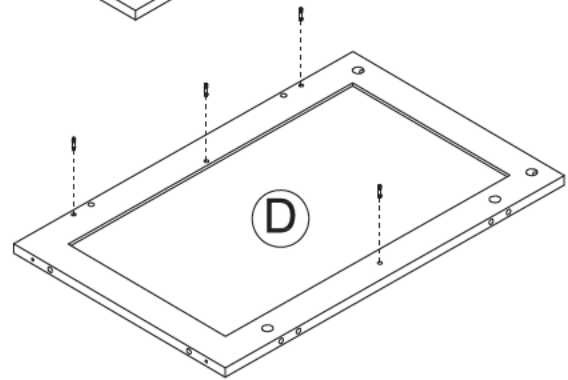
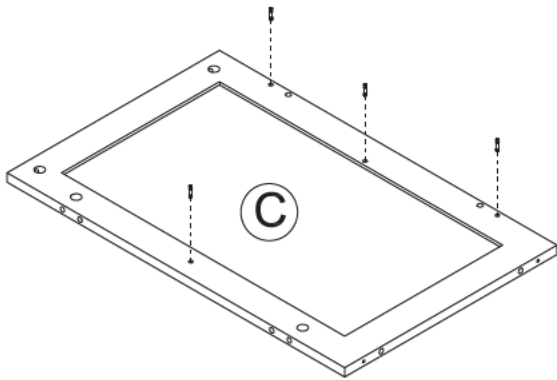
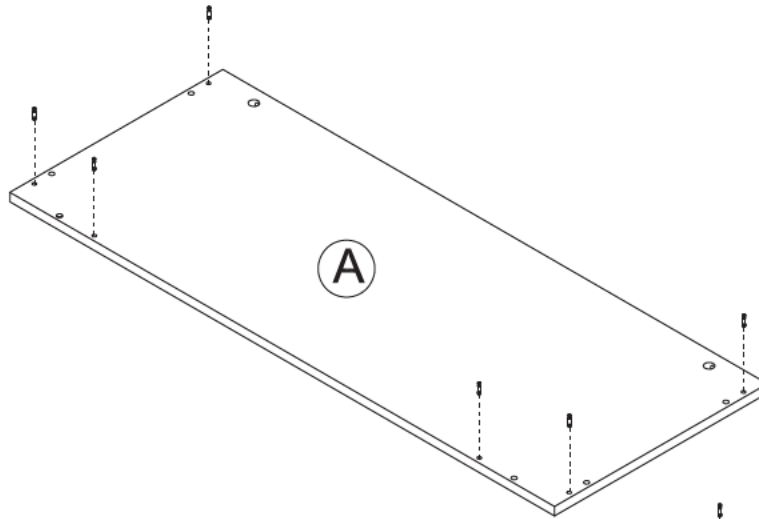

# Step 2

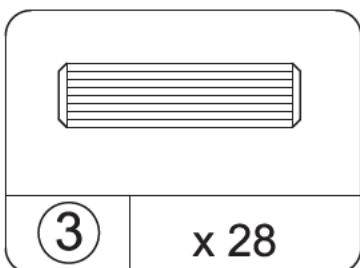
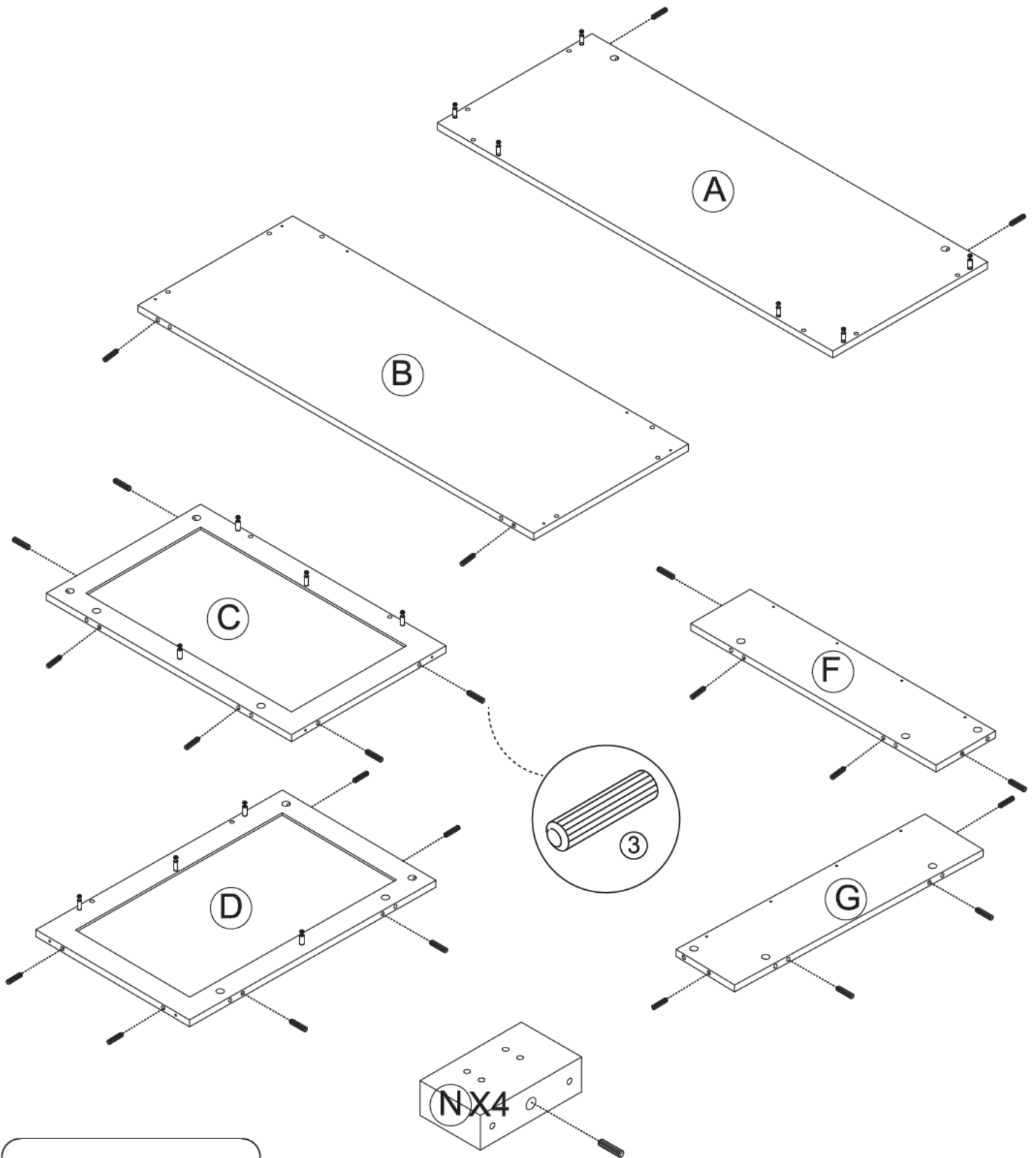

# Step 3

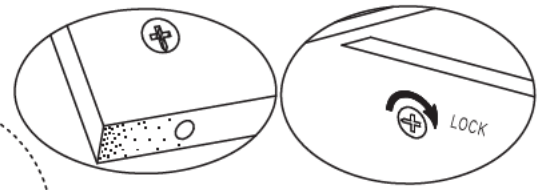
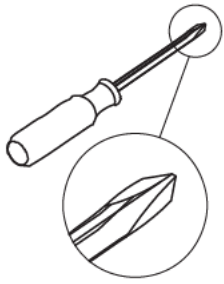

Proper orientation of CAM LOCK

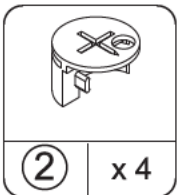
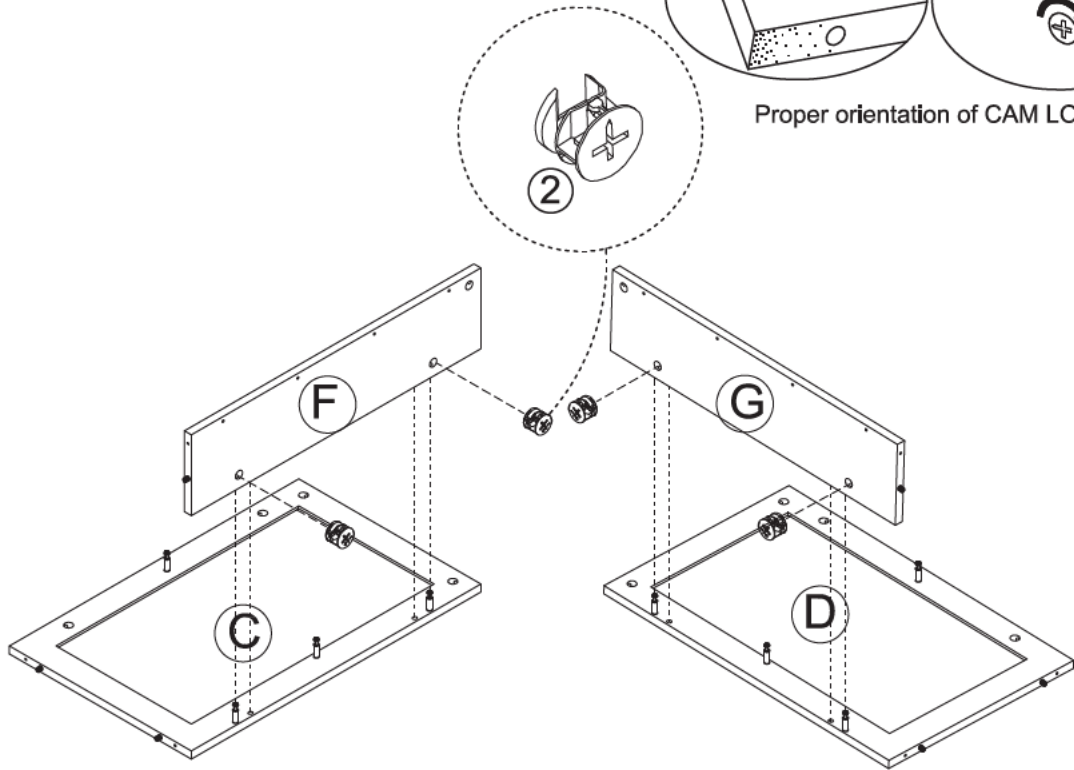

# Step 4

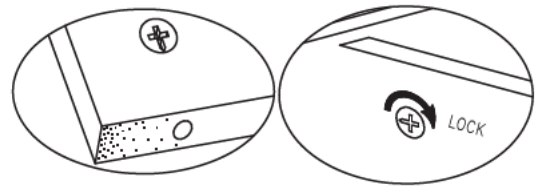
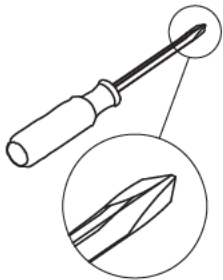

Proper orientation of CAM LOCK

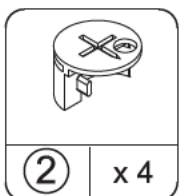
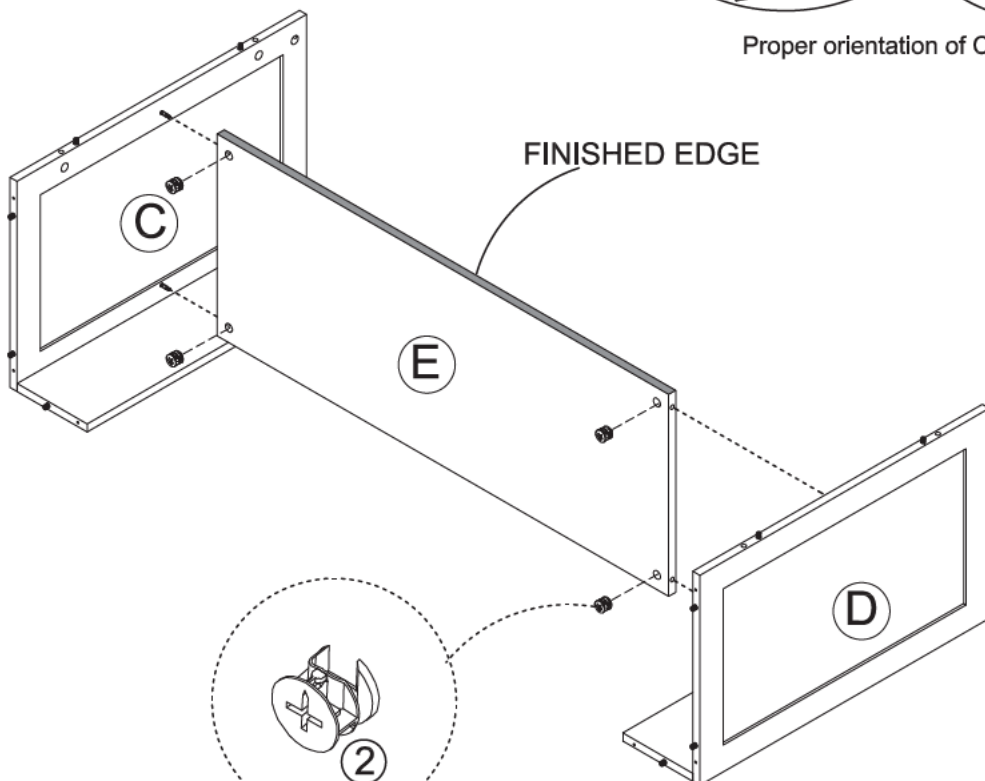

# Step 5

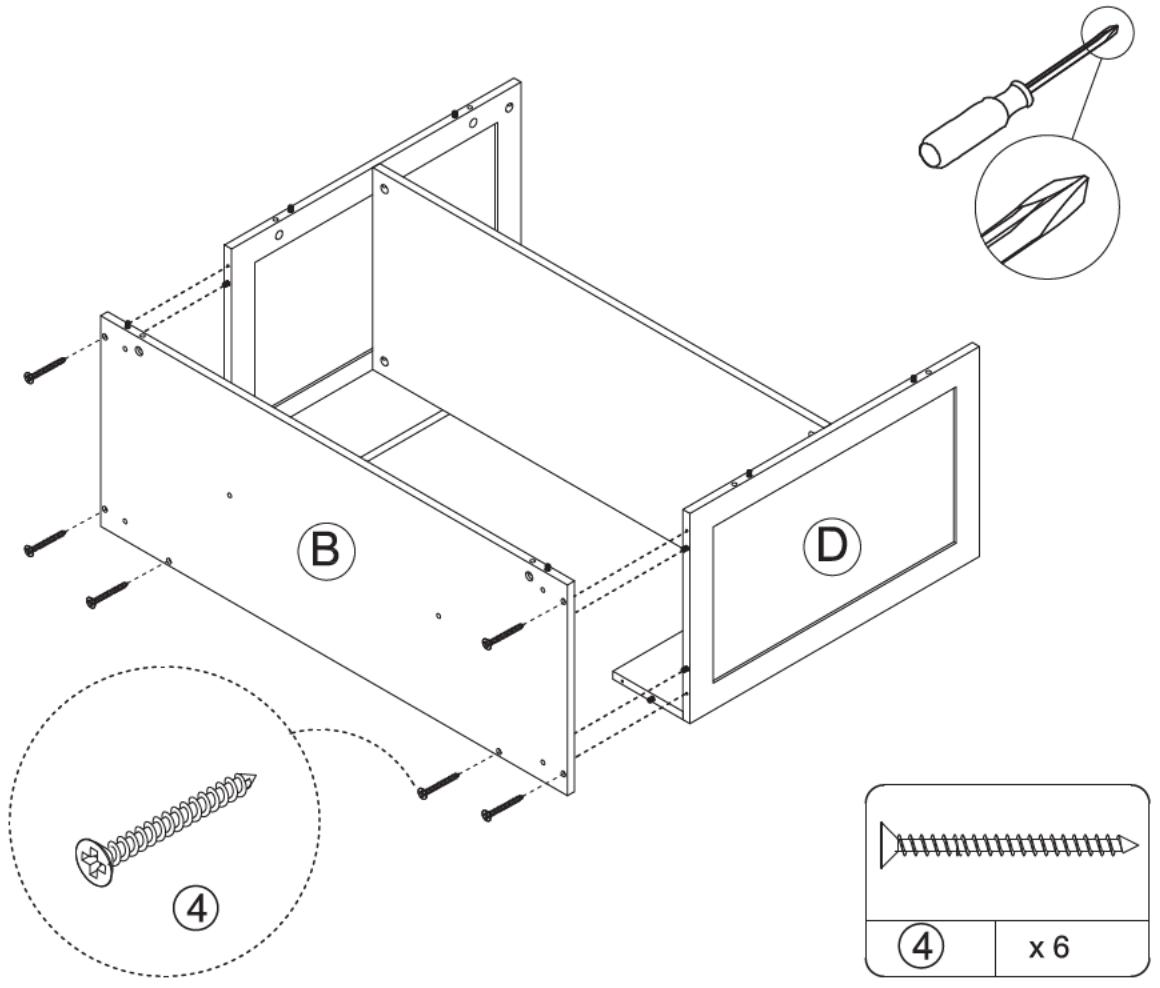

# Step 6

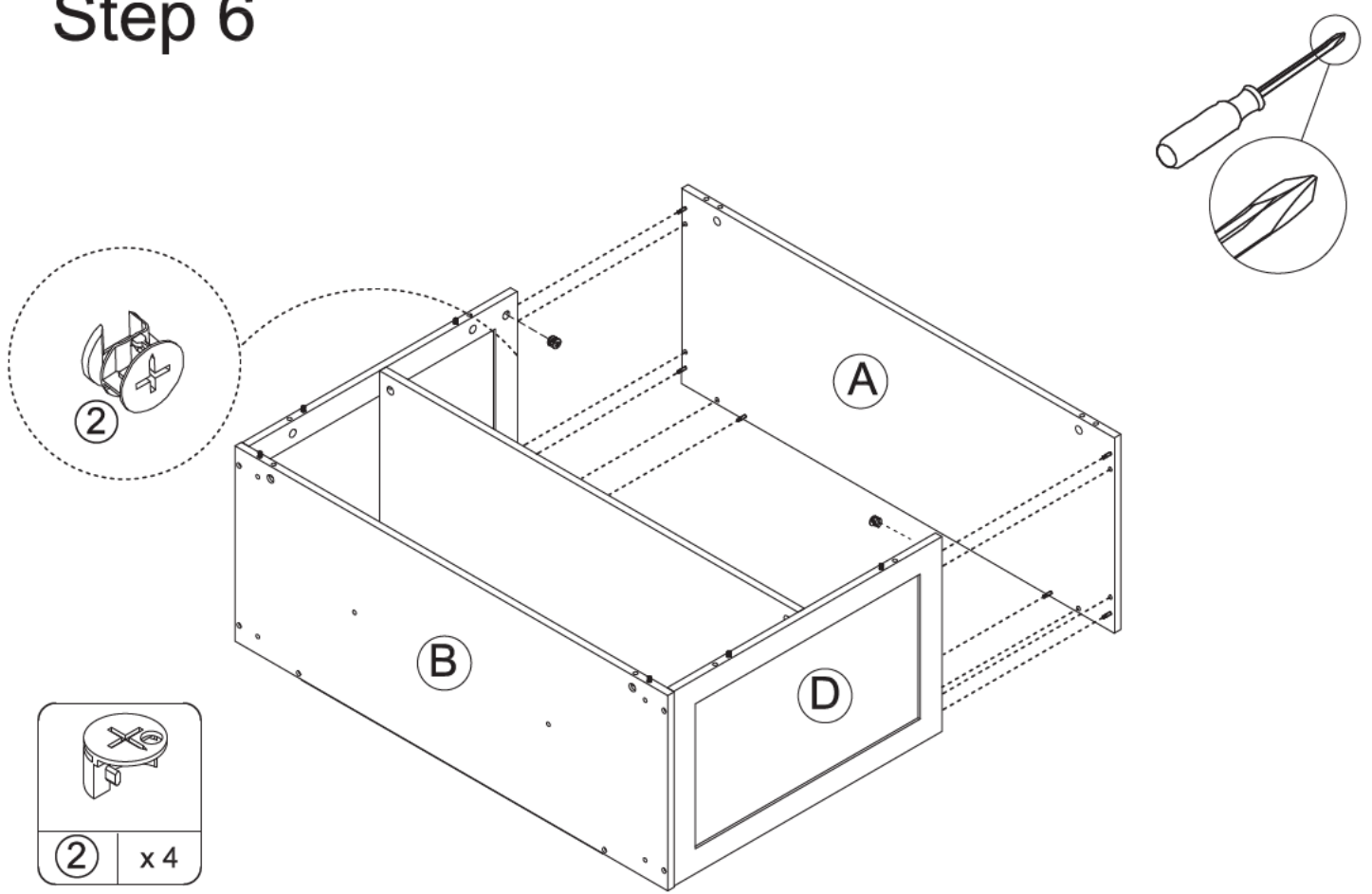

# Step 7

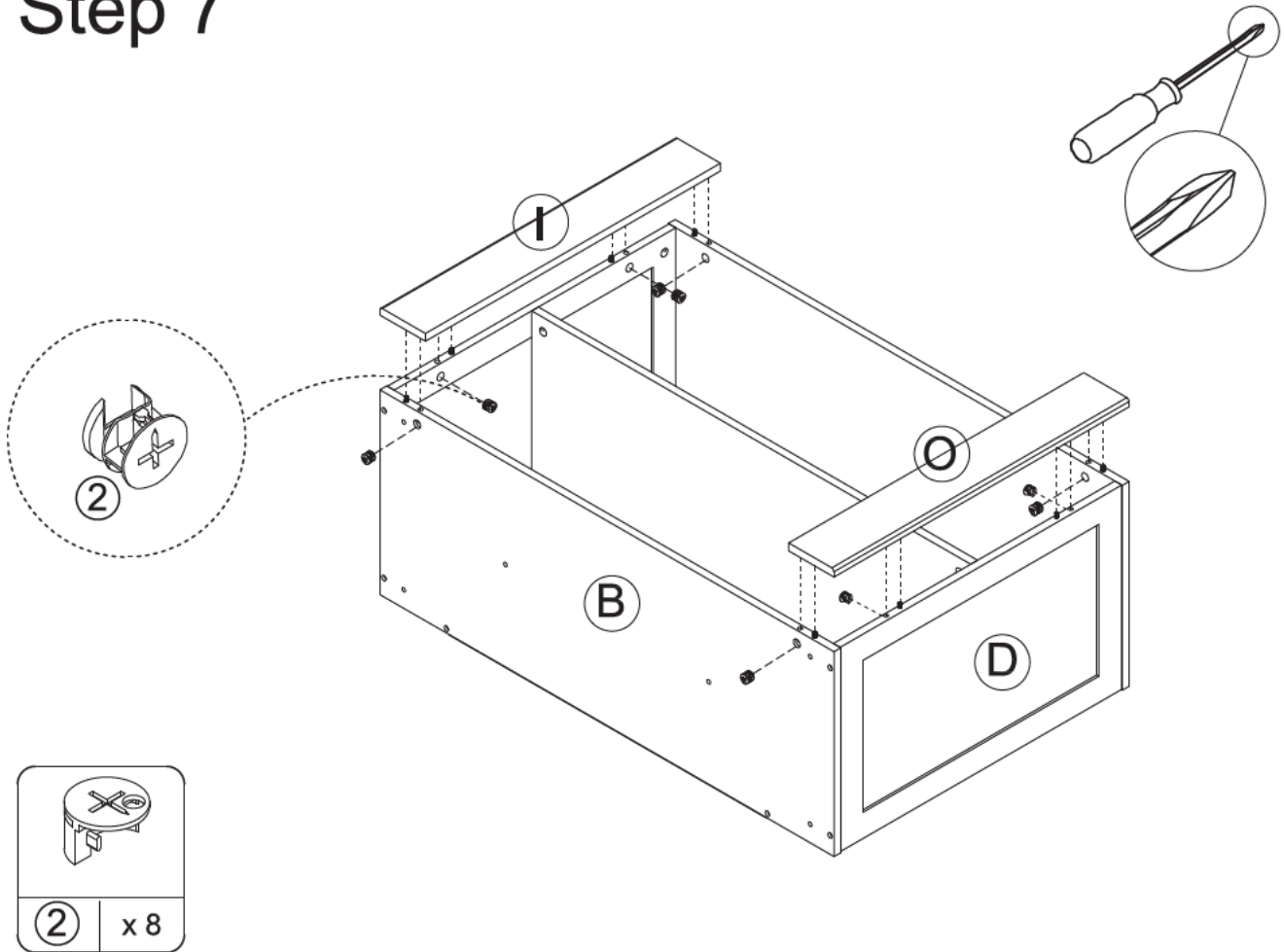

# Step 8

Do Not Screw Hardware Part 6 Tightly At This Step

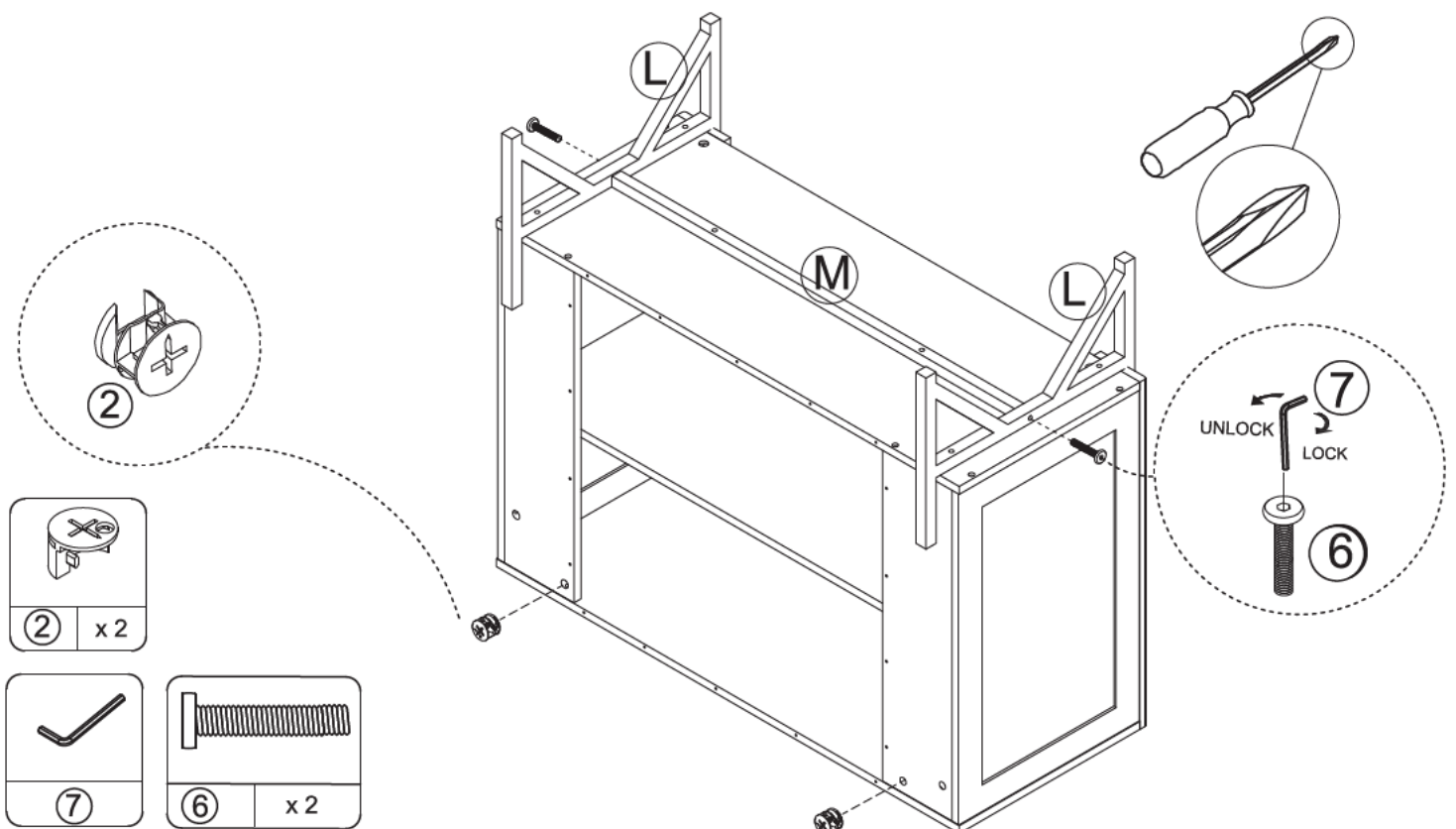

Parts 9

# Step 9

Please Lock All Screws Tightly At This Step

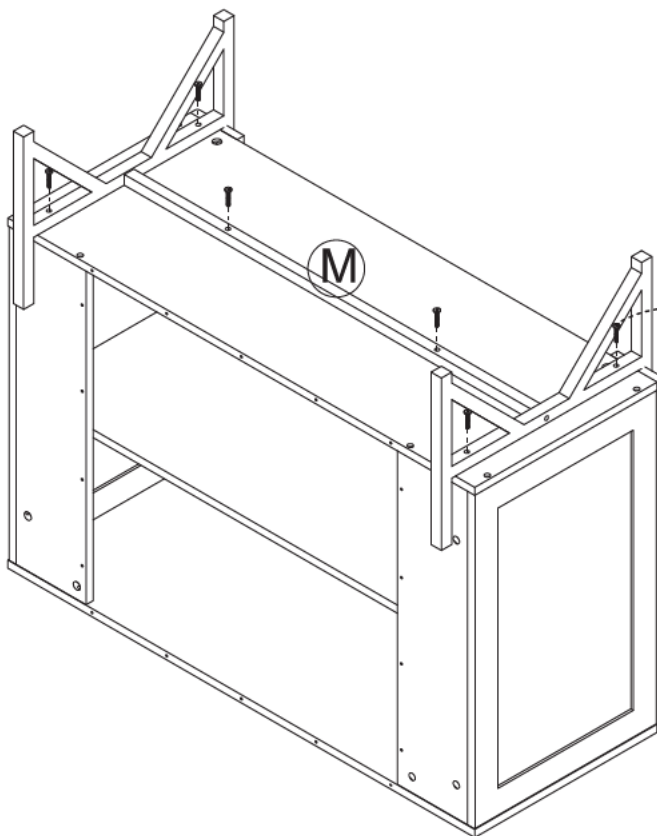
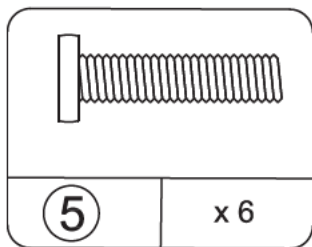
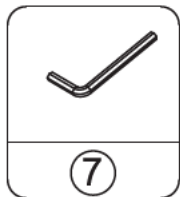

# Step 10

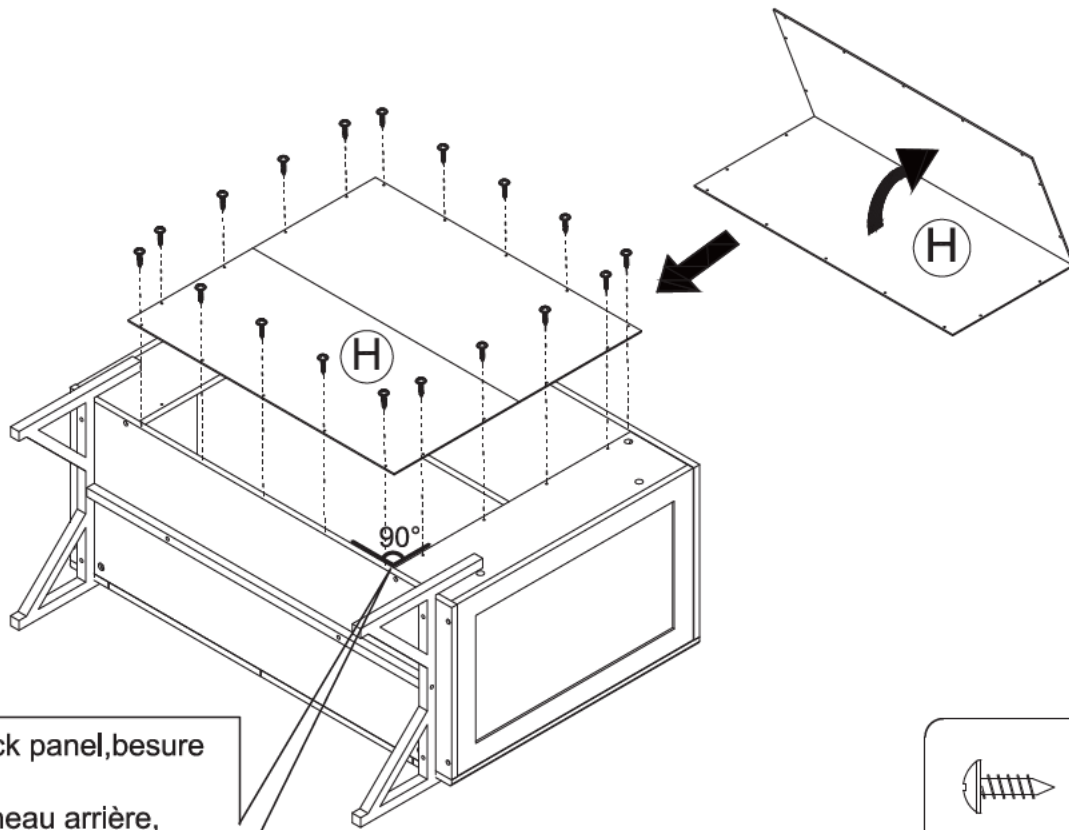
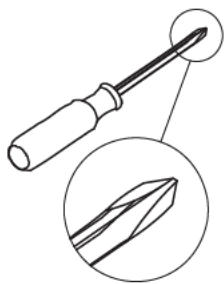

Before attaching the back panel, be sure that the unit is at 90°  
Avant d'attacher le panneau arrière, assurez-vous que l'unité est à 90°  
Antes de fijar el panel posterior, asegúrese de que la unidad esté a 90°

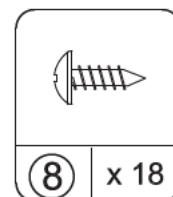

# Step 11

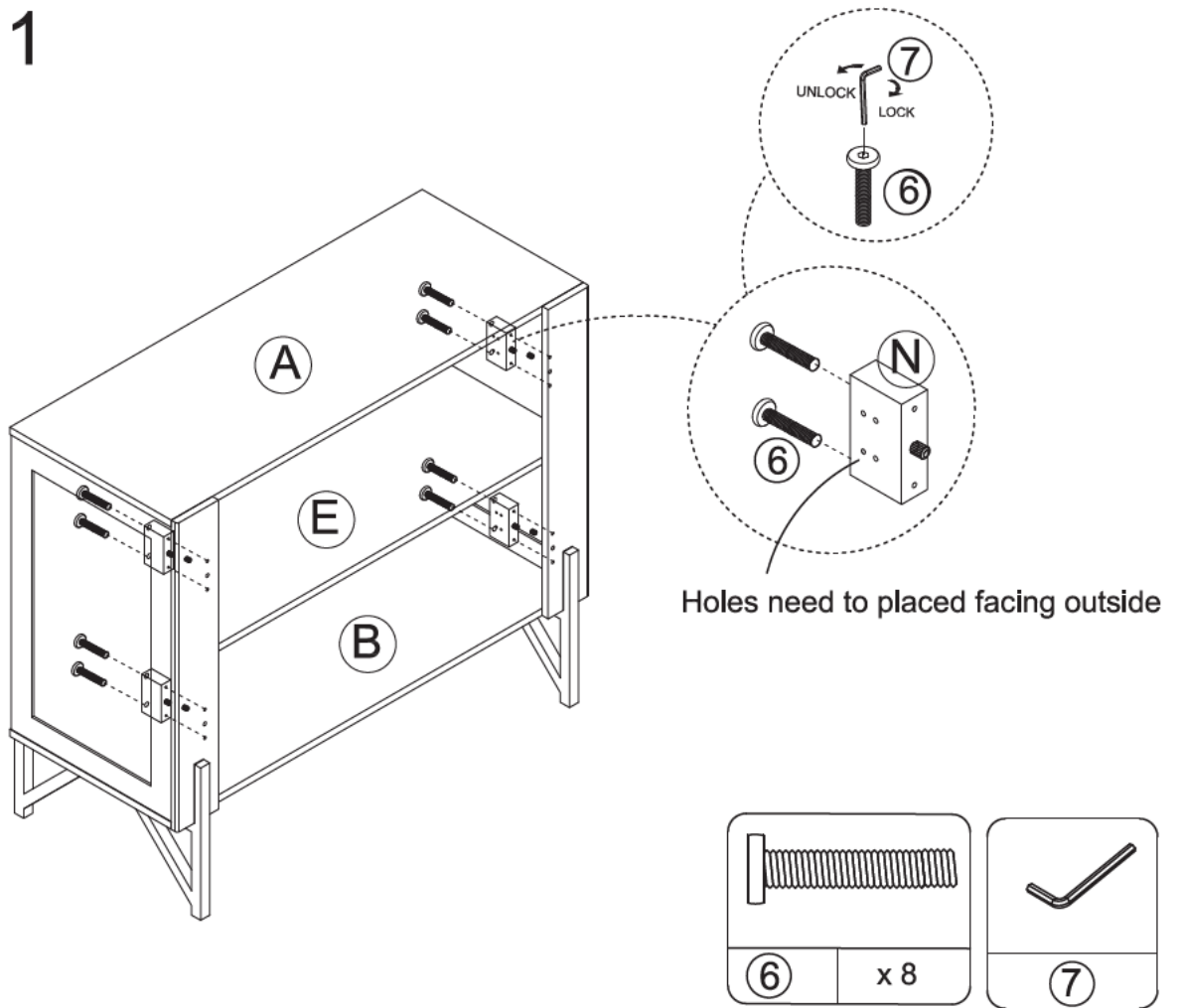

# Step 12

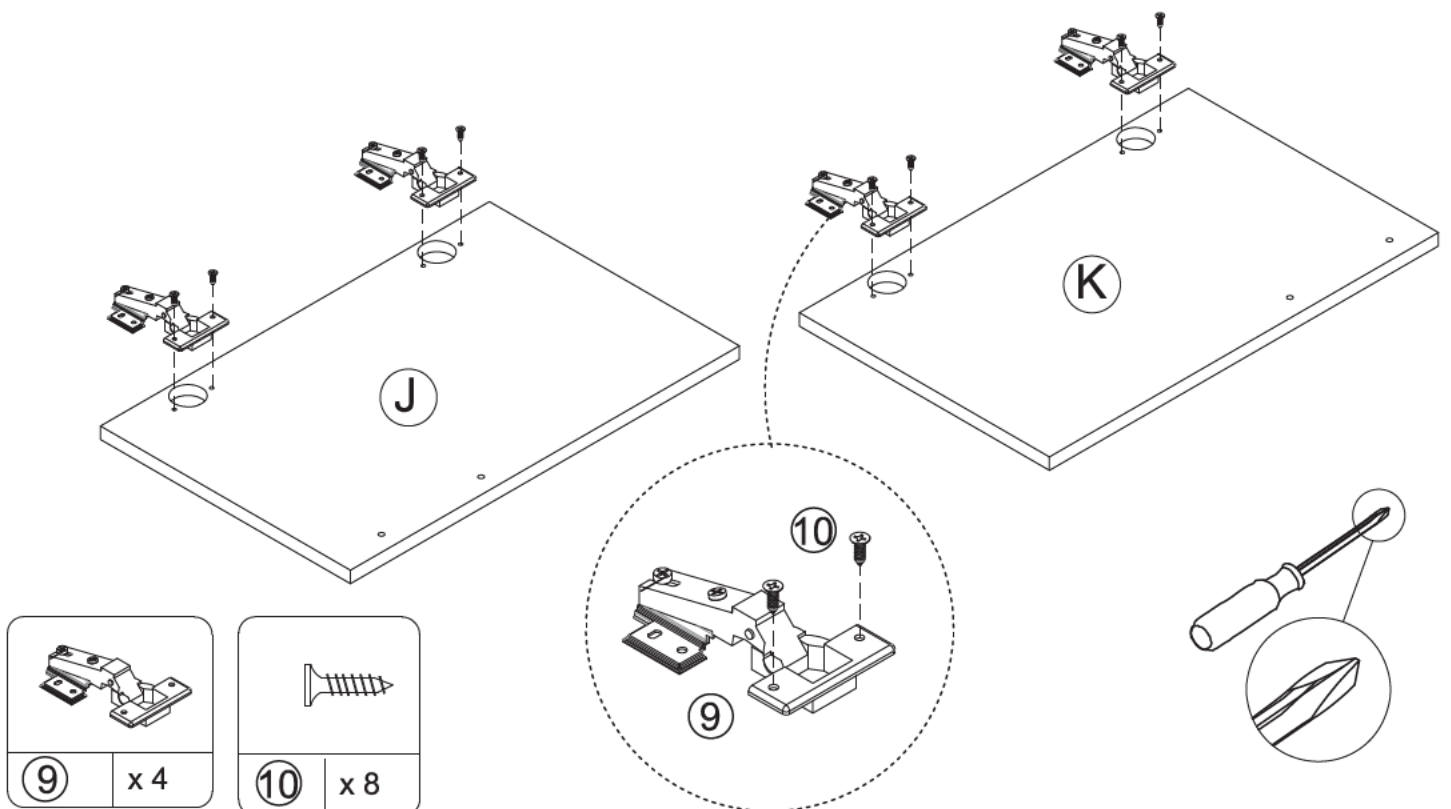

# Step 13

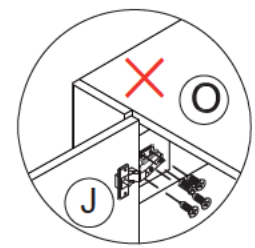
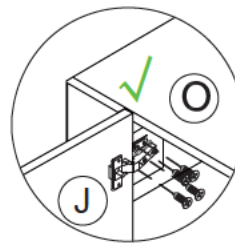
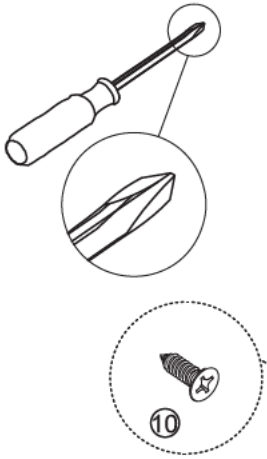

Make sure parts "J" and "O" are assembled aligning with parts "H" and "T"

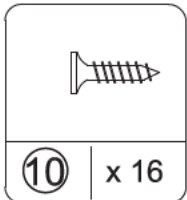
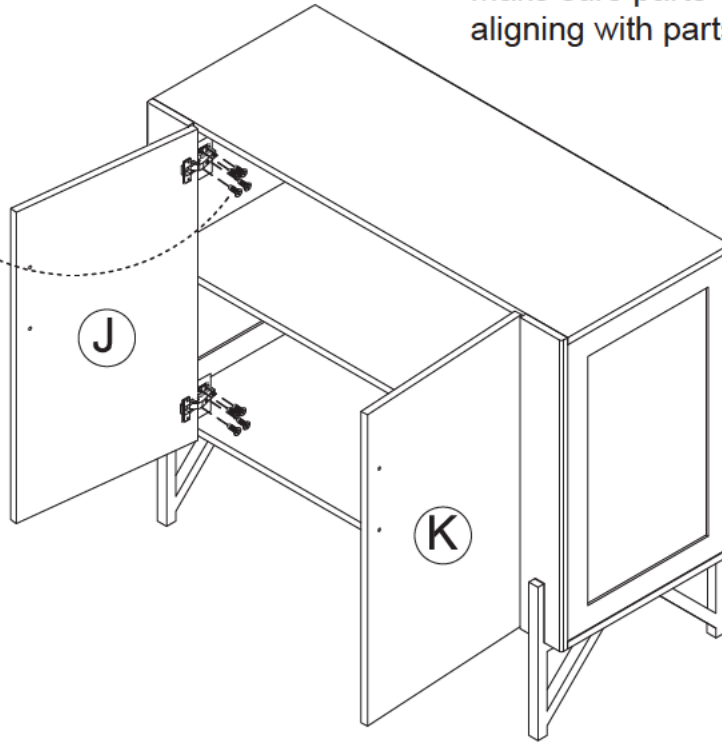

# Step 14

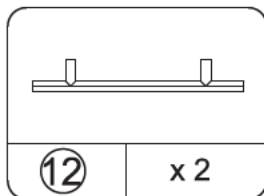
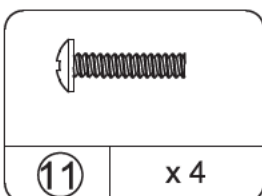
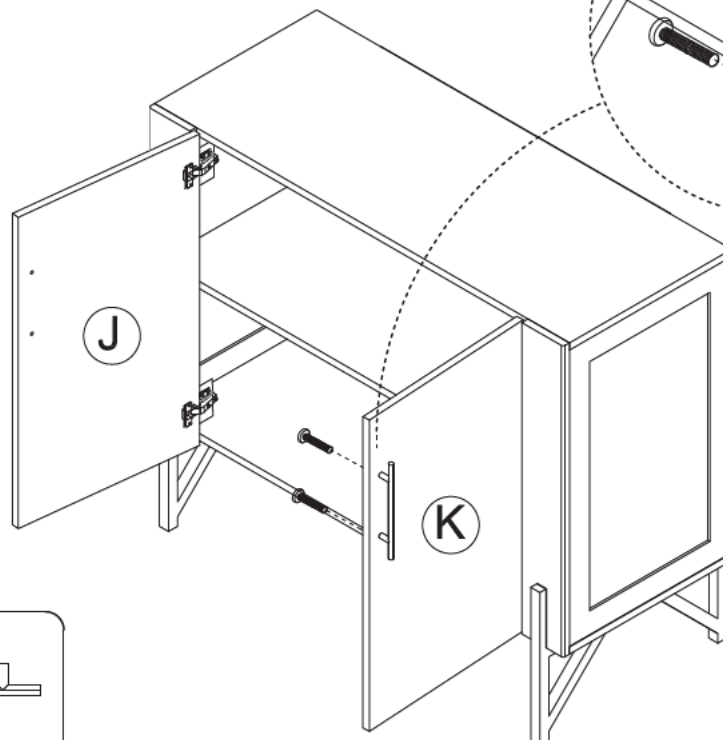
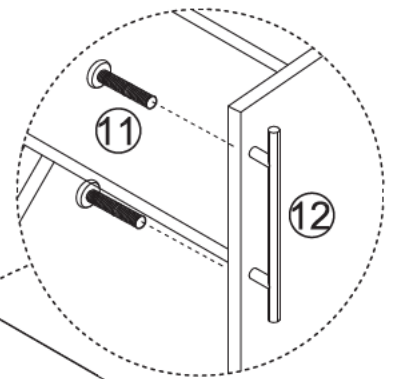

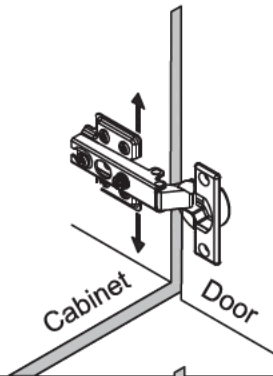
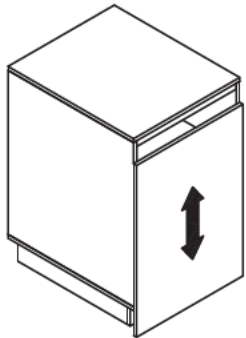
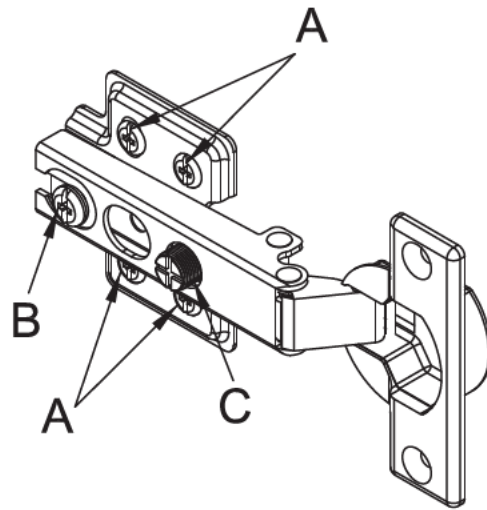

**To adjust the vertical height.**

Loosen the four screws "A" on both hinges. Two of them are usually in slotted holes which allows you to adjust up or down by a few mm. Then tighten back up.

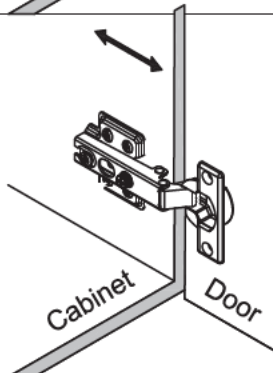
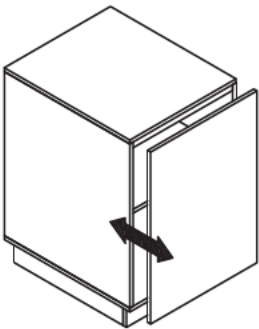

**To adjust depth.**



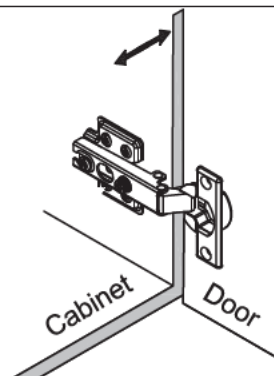
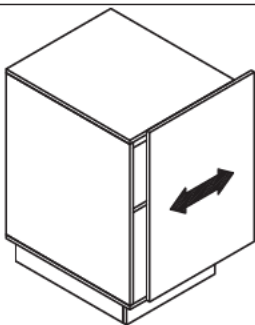

Loosen screw "B" and adjust door, if the door can not be adjusted, please loosen screw "C", then try again. Tighten screw "B" and "C".



**To adjust side ways.**

Turning the screw "C" on BOTH hinges on each door.

# Step 15

PART LIST	FIGURE	QUANTITY	DESCRIPTION
13.1		2PC	LONG SCREW (Dia.4mmX38mmL)
13.2		2PC	SHORT SCREW (Dia.4mmX19mmL)
13.3		4PC	METAL "L"BRACKET
13.4		2PC	PLASTIC ANCHOR
13.5		2PC	CABLE

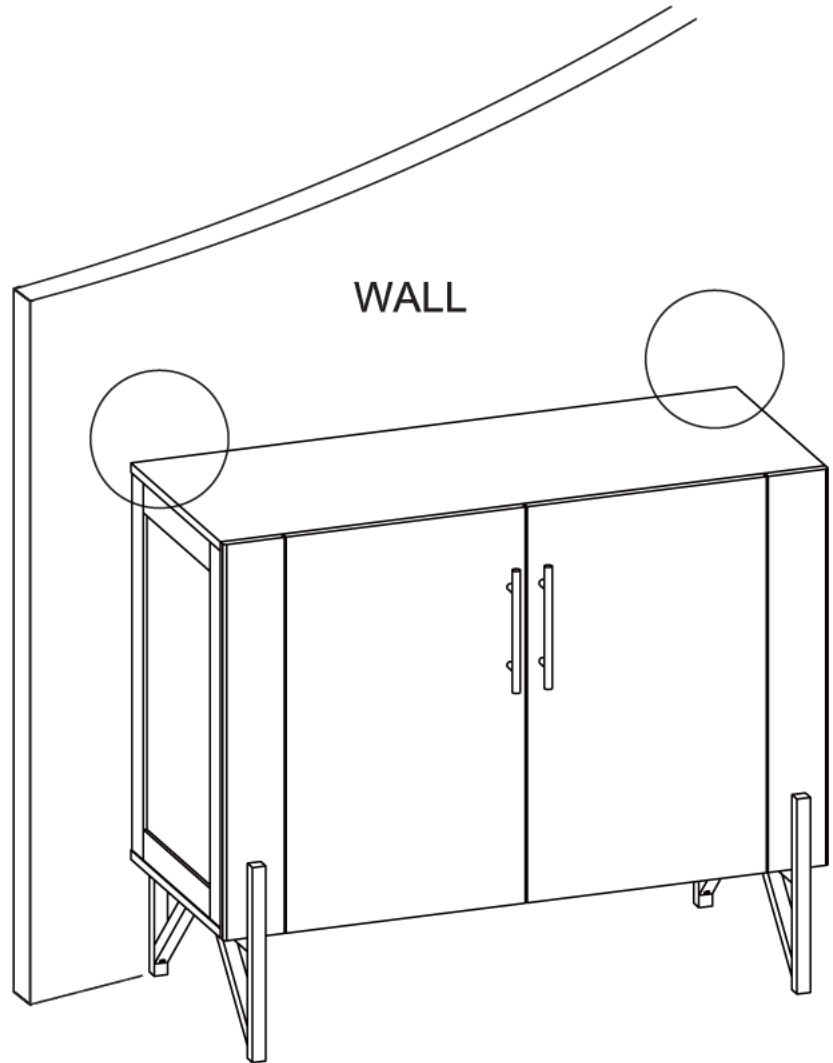
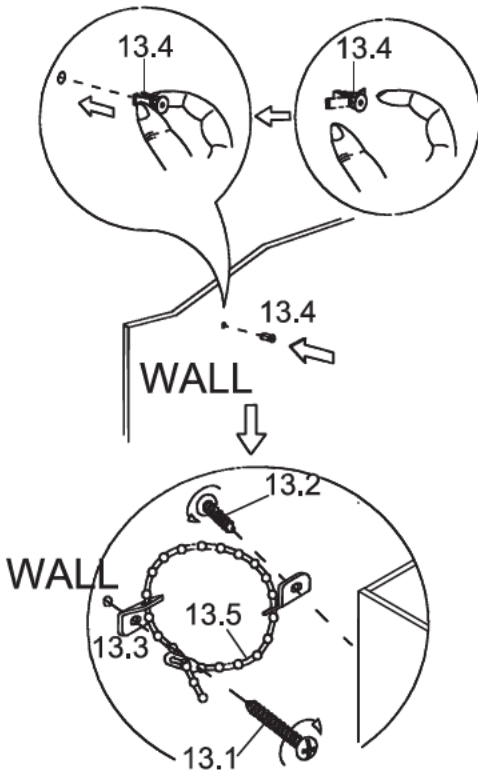
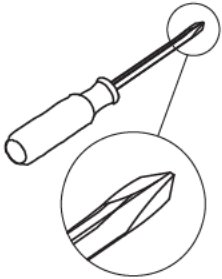
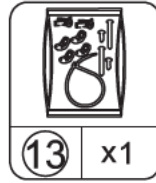

Follow the instructions printed on the plastic bag containing the tipping restraint hardware to attach the tip-over restraints to the unit and the wall.

**NOTE:**The tipping restraint hardware included is for drywall construction. It will be necessary to drill holes for the wall anchors. Depending upon your wall construction, different anchor hardware may be required. Please contact your local hardware store for assistance.

# Safety Maximum Loads

---

This unit has been designed to support the maximum loads shown. Exceeding these load limits could cause sagging, instability, product collapse, and/or serious injury.

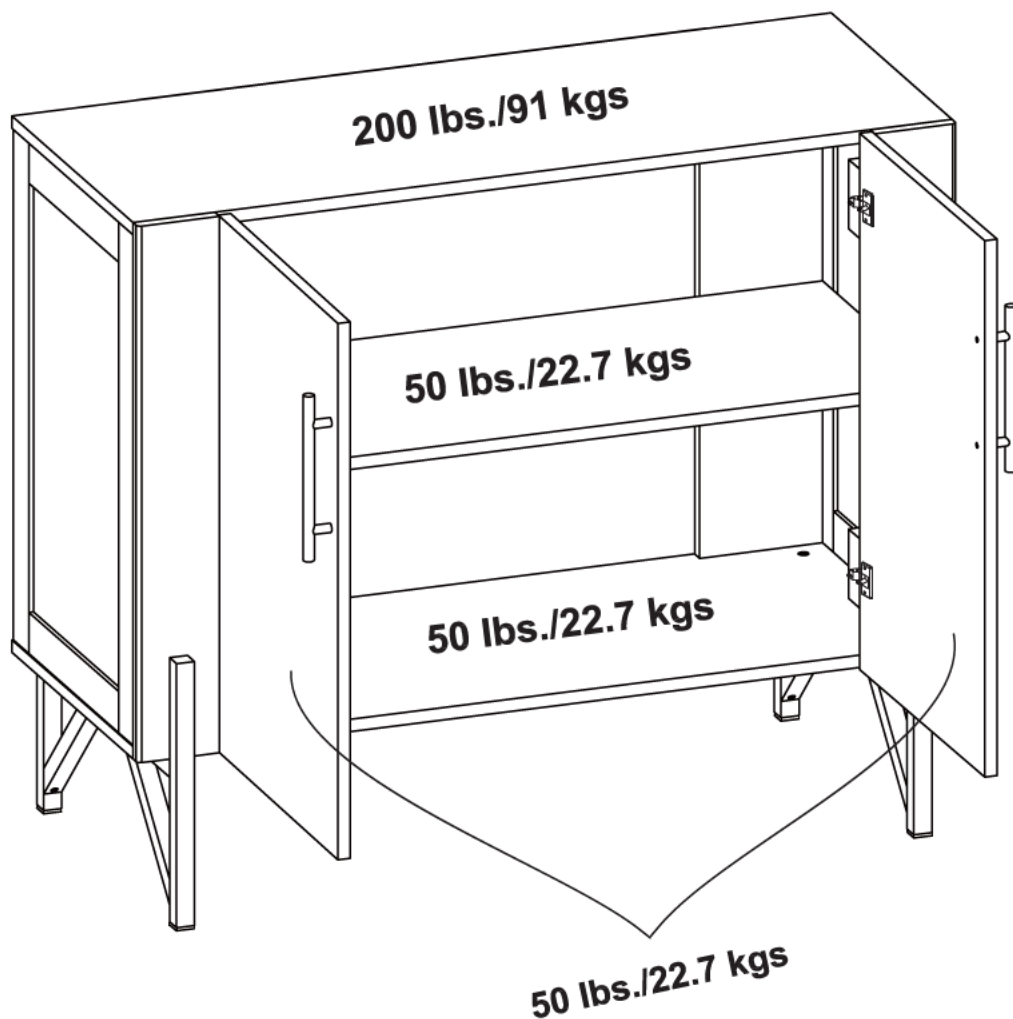

## **WARNING**

Please make sure that all objects are removed before moving the assembled unit. The unit must be team lifted, not dragged or pushed. Failure to do so could cause instability, product collapse, and/or serious injury.