

ASSEMBLY INSTRUCTIONS





TABLE,3-PACK ONLY

Read instructions carefully prior to assembly.





Thank you for purchasing this quality product. Check carefully for small parts which may come loose during shipment. Remove all components from pack and place top down on soft surface such as carpet or cloth to prevent scratching the finish. Identify and count all parts as specified below.

It is recommended to use two or more persons during the assembly process.

Hardware List For End Table

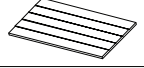
No.	Description	Sketch	Size	Q.ty
1	Allen Key		M4x58x23	1 pc
2	Allen Bolt		1/4 x 19mm	30 pcs
3	Spring Washer		1/4 x Ø12 x 1mm	30 pcs
4	Flat Washer		1/4 x Ø16 x 2mm	30 pcs

Parts List

No.	Description	Sketch	Q.ty
A	Cocktail Table top		1 pc
B	Cocktail Legs Frame		2 pcs
C	Cocktail Bottom Panel		1 pc
D	Cocktail Apron		2 pcs

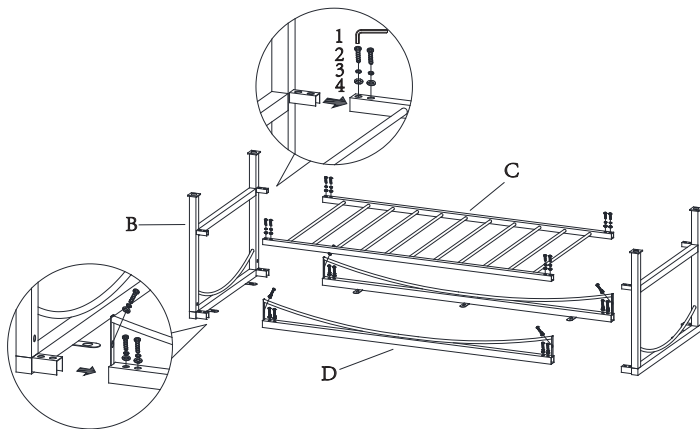

Step 1: Attach two Legs Frame(B) to the Apron(D) and Bottom Panel(C) by using Flat Washer(4), Spring Washer(3), Bolt(2) and Allen Key(1). DO NOT fully tighten the bolts.

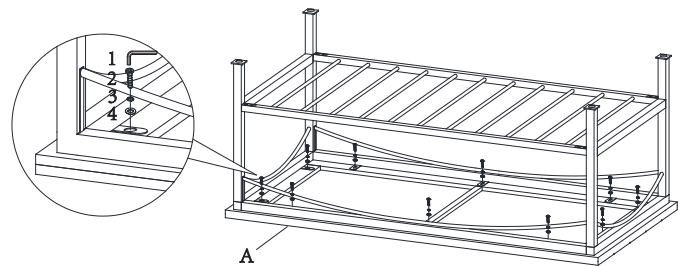

Step 2: Place Table Top(A) on a flat, soft surface such as a carpet or a cloth to prevent scratching the table finish. Attach the Metal group to the Table Top(A) by using Flat Washer(4), Spring Washer(3), Bolt(2) and Allen Key(1).

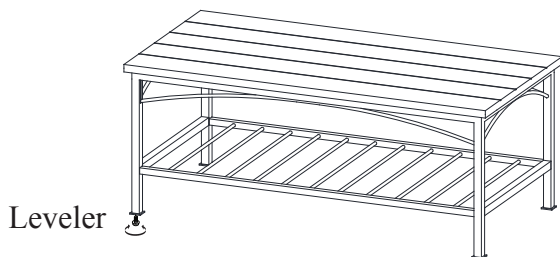

Step 3: Turn over the table and tighten all bolts carefully. Assembly is completed. If levelling is necessary, adjust the levelers turn clockwise or counter clockwise.

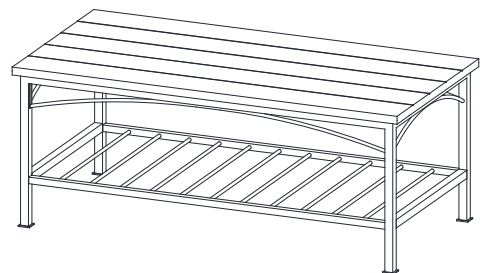

Step 4: Completed.

Cleaning instructions: Clean using soft cloth

ASSEMBLY INSTRUCTIONS





TABLE,3-PACK ONLY

Read instructions carefully prior to assembly.



Thank you for purchasing this quality product. Check carefully for small parts which may come loose during shipment. Remove all components from pack and place top down on soft surface such as carpet or cloth to prevent scratching the finish. Identify and count all parts as specified below.

It is recommended to use two or more persons during the assembly process.

Hardware List For End Table

No.	Description	Sketch	Size	Q.ty
1	Allen Key		M4x58x23	1 pc
2	Allen Bolt		1/4 x 19mm	28 pcs
3	Spring Washer		1/4 x Ø12 x 1mm	28 pcs
4	Flat Washer		1/4 x Ø16 x 2mm	28 pcs

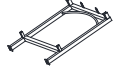
Parts List

No.	Description	Sketch	Q.ty
A	End Table top		1 pc
B	End Legs Frame		2 pcs
C	End Bottom Panel		1 pc
D	End Apron		2 pcs

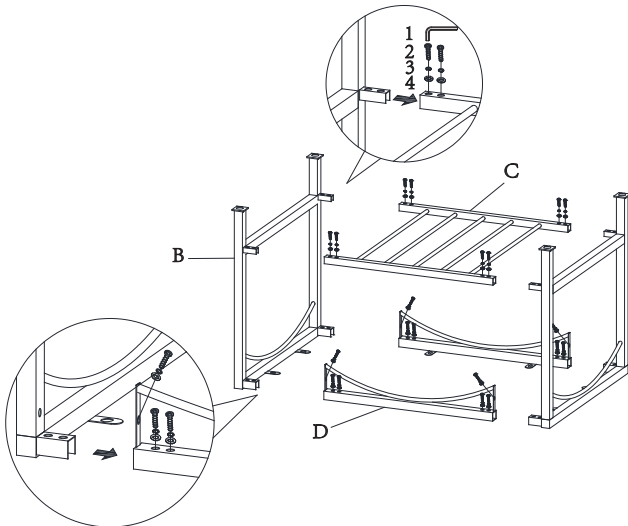

Step 1: Attach two Legs Frame(B) to the Apron(D) and Bottom Panel(C) by using Flat Washer(4), Spring Washer(3), Bolt(2) and Allen Key(1). DO NOT fully tighten the bolts.

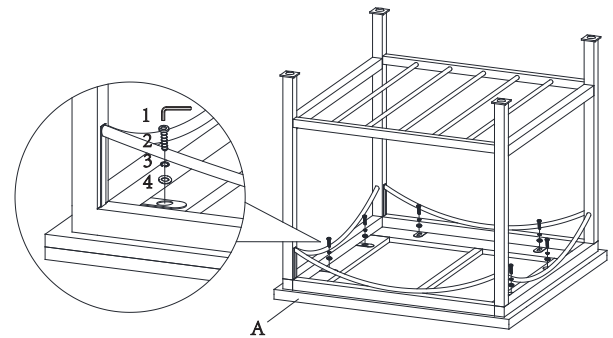

Step 2: Place Table Top(A) on a flat, soft surface such as a carpet or a cloth to prevent scratching the table finish. Attach the Metal group to the Table Top(A) by using Flat Washer(4), Spring Washer(3), Bolt(2) and Allen Key(1).

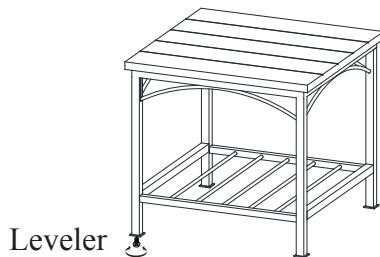

Step 3: Turn over the table and tighten all bolts carefully. Assembly is completed. If levelling is necessary, adjust the levelers turn clockwise or counter clockwise.

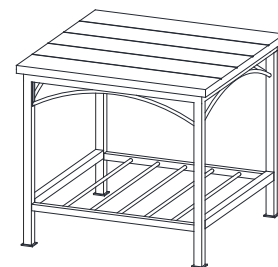

Step 4: Completed.

Cleaning instructions: Clean using soft cloth