

ROUND COFFEE TABLE

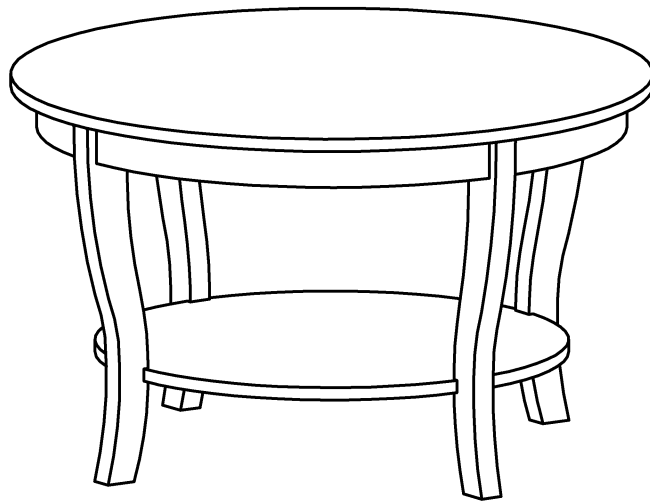





Assembly Instruction

We have designed our furniture with you, the customer in mind. Our clear, easy to follow step by step instructions will guide you through the project from start to finish. Feel confident that this will be a fun and rewarding project. The final product will be a quality piece of furniture that will go together smoothly and give years of enjoyment.

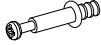
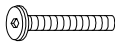
Please verify all parts are present before beginning assembly

Hardware List

			
Camlock (4 pcs)	Cambolt (4 pcs)	Allen Bolt (4 pcs)	Spring Washer (4 pcs)
			
Flat Washer (4 pcs)	Allen wrench (1 pc)		

Parts List

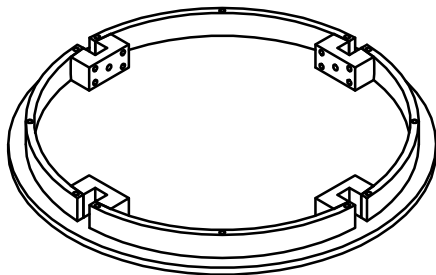

(1)- **Top** (1 pc)

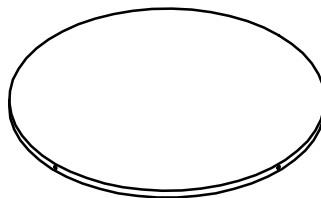

(2)- **Bottom Shelf** (1 pc)

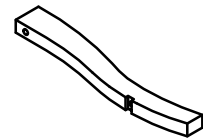

(3)- **Leg** (4pcs)

Assembling the unit with camblock

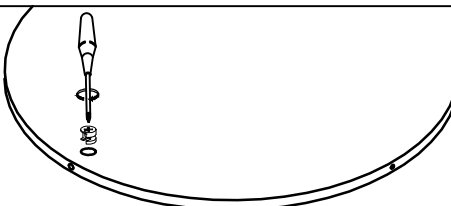

Insert camlock, arrow must face bolt hole

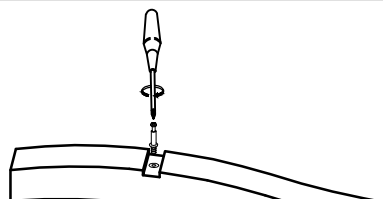

Gently screw cambolt into the threaded anchor

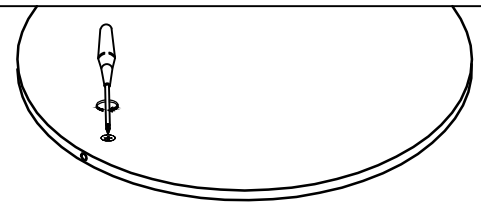

Gently screw the camlock wise into locked position.
Do not over tighten

Assemble unit on carpet or other soft surface

Step 1

1. Screw cambolts (B) into legs (3) . Make sure to do this with all 4 legs.

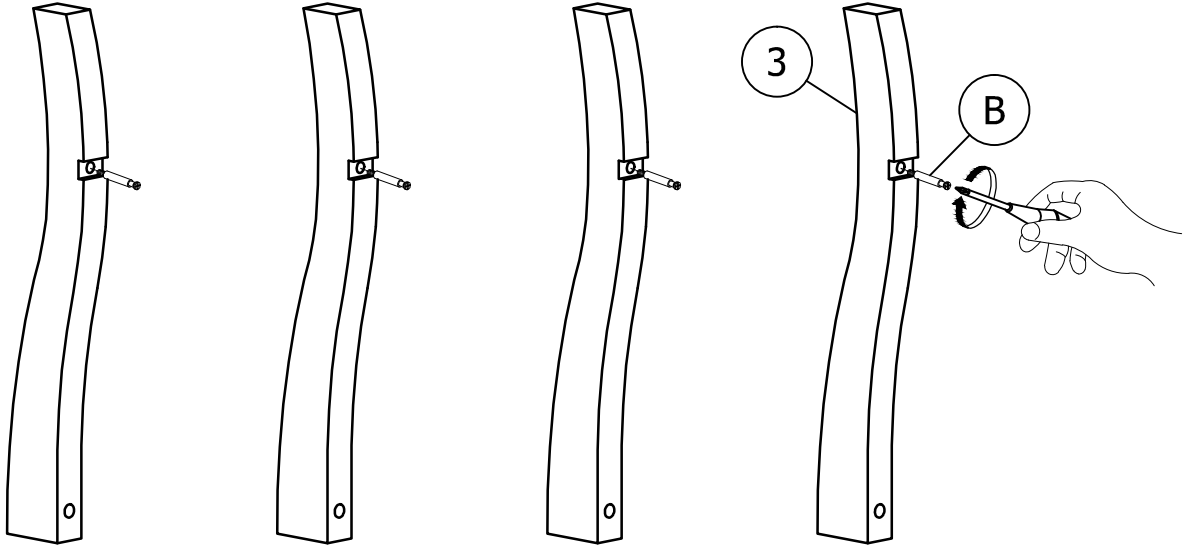

Step 2

1. Attach 2 Legs (3) to Top (1) using Allanbolt (C), Spring Washer (D), Flat washer (E) and Allen Wrench (F).
2. Do not fully tighten Allanbolts (C).

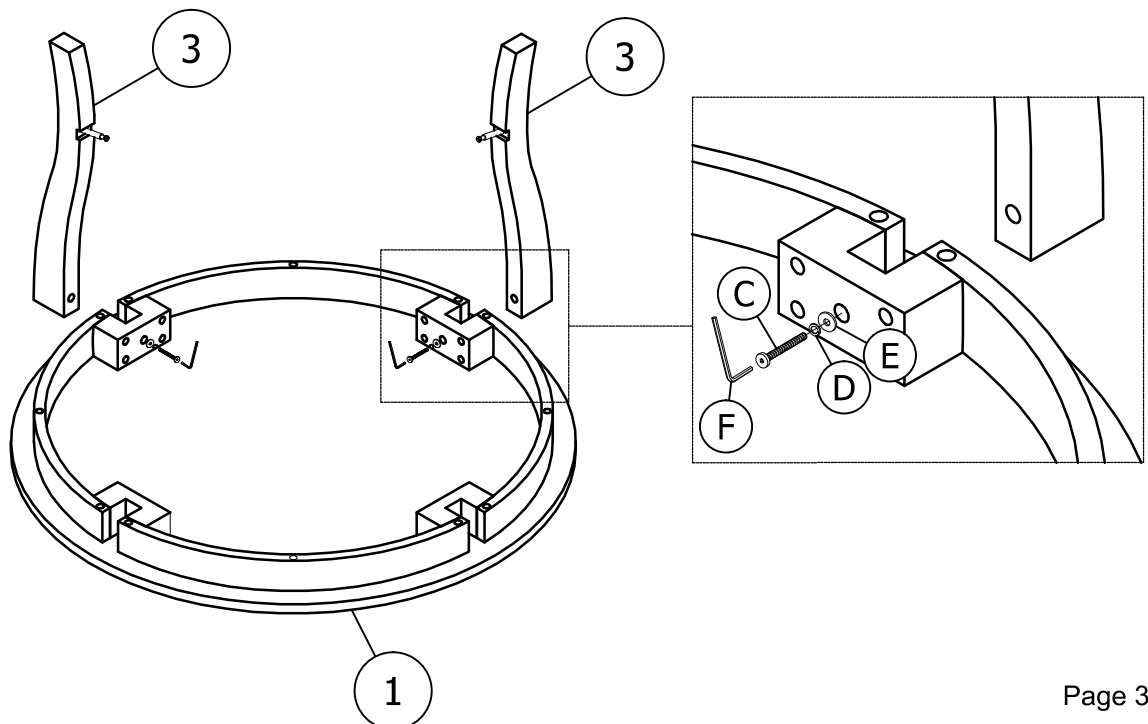

Assemble unit on carpet or other soft surface

Step 3

1. Insert Camlock (A) into Bottom Shelf (2) .
2. Insert Bottom Shelf (2) into groove of legs (3) as shown .
3. Gently tighten Camlocks .
4. Attach remaining legs to unit
5. Fully tighten all Allen Bolts .

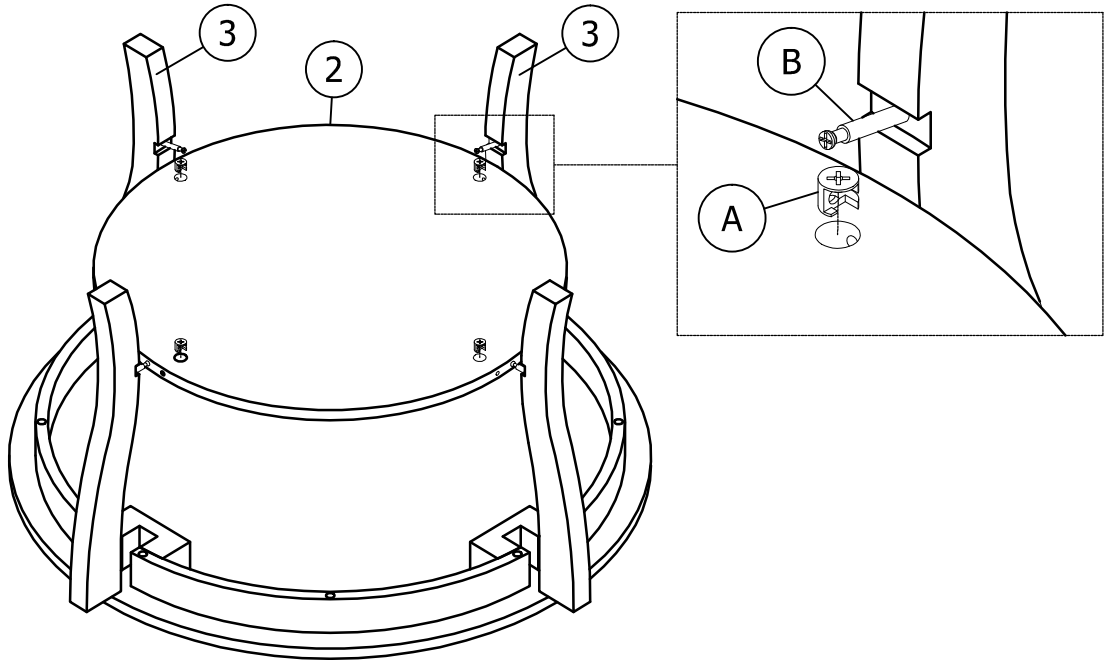

Step 4

1. Enjoy

