

# ASSEMBLY INSTRUCTIONS

## INSTRUCCIONES DE ENSAMBLE



Height: 29,52 in  
Width: 47,24 in  
Depth: 21,65 in

Alto: 75 cm  
Ancho: 120 cm  
Fondo: 55 cm



## IMPORTANT RECOMMENDATIONS

Do not paint the cabinet.

The cabinet **MUST** be used exclusively indoors, do not expose to direct sun.

Clean metallic hardware with a dry cloth.

Do **NOT** overload the cabinet (see suggested loads).

Do not hit or hammer the cabinet (just when indicated).

Clean with a slightly damp cloth, use gentle soaps.

Do not drag, lift and move between two people.

Avoid direct contact with water, fire or exposure to heat sources.

## RECOMENDACIONES IMPORTANTES

No pintar el mueble.

El mueble debe ser usado únicamente en interiores, no exponer al sol directo.

Limpiar los herrajes metálicos con un paño seco.

**NO** sobrecargar el mueble (ver las cargas sugeridas).

No golpear ni martillar el mueble (solo cuando se indique).

Limpiar con un paño ligeramente húmedo, usar jabones suaves.

No arrastre el mueble, levántelo entre dos personas.

Evite el contacto directo con el agua, el fuego o la exposición a fuentes de calor.



### WARNING

Never allow children to climb or manipulate the cabinet, furniture tip over can cause serious injuries or death.



### ADVERTENCIA

Nunca permita que los niños escalen o manipulen el mueble, la caída de este puede provocar lesiones graves o la muerte.

# INDEX

# ÍNDICE

Assembly Hardware .....	4	Herrajes para Armado.....	4
Assembly Parts .....	5	Piezas de Armado.....	5
Suggested Loads.....	6	Cargas Sugeridas.....	6
Assembly Recommendations.....	6	Recomendaciones de Ensamble.....	6
Assembly Steps .....	7-16	Pasos de Armado.....	7-16
Warranty.....	17	Garantía .....	17

## REQUIRED TOOLS\*

## HERRAMIENTAS NECESARIAS\*

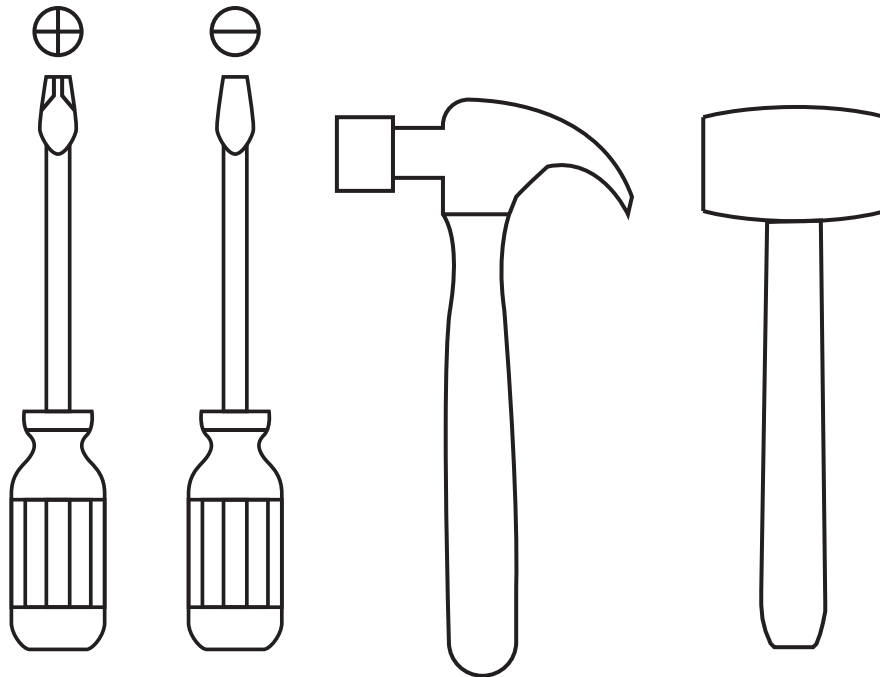

\*Not included, and not shown actual size.

\*No incluidas y no se muestran en tamaño real.

# ASSEMBLY HARDWARE

# HERRAJES PARA ARMADO

Please check that the hardware content is correct. If any item is missing, please call to our customer service line.

Compruebe que el contenido de los herrajes sea el correcto. En caso de que falte alguna pieza, por favor llame a nuestra línea de atención al cliente.

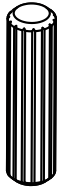

**x54**

Wood Dowel  
Tarugo



**x47**

Spreading Bolt  
Perno Minifix



**x47**

Minifix Cams  
Minifix



**x47**

Cover Caps  
Tapa Adhesiva  
Minifix

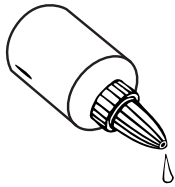

**x1**

Glue  
Pegante



**x24**

Sheet Screw  
Tornillo lamina  
9/16



**x12**

Drywall Screw  
Tornillo Ensamble  
2"



**x3**

Handle Screw  
Tornillo Manija



**x3**

Drawer Slide  
Riel Importado

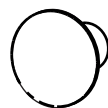

**x3**

Cabinet Knob  
Manija Botón



**x6**

Drywall Screw  
Tornillo Ensamble  
1" 1/4

Hardware items are NOT shown actual size.

Los herrajes no se muestran en el tamaño real.

# ASSEMBLY PARTS

# PIEZAS DE ARMADO

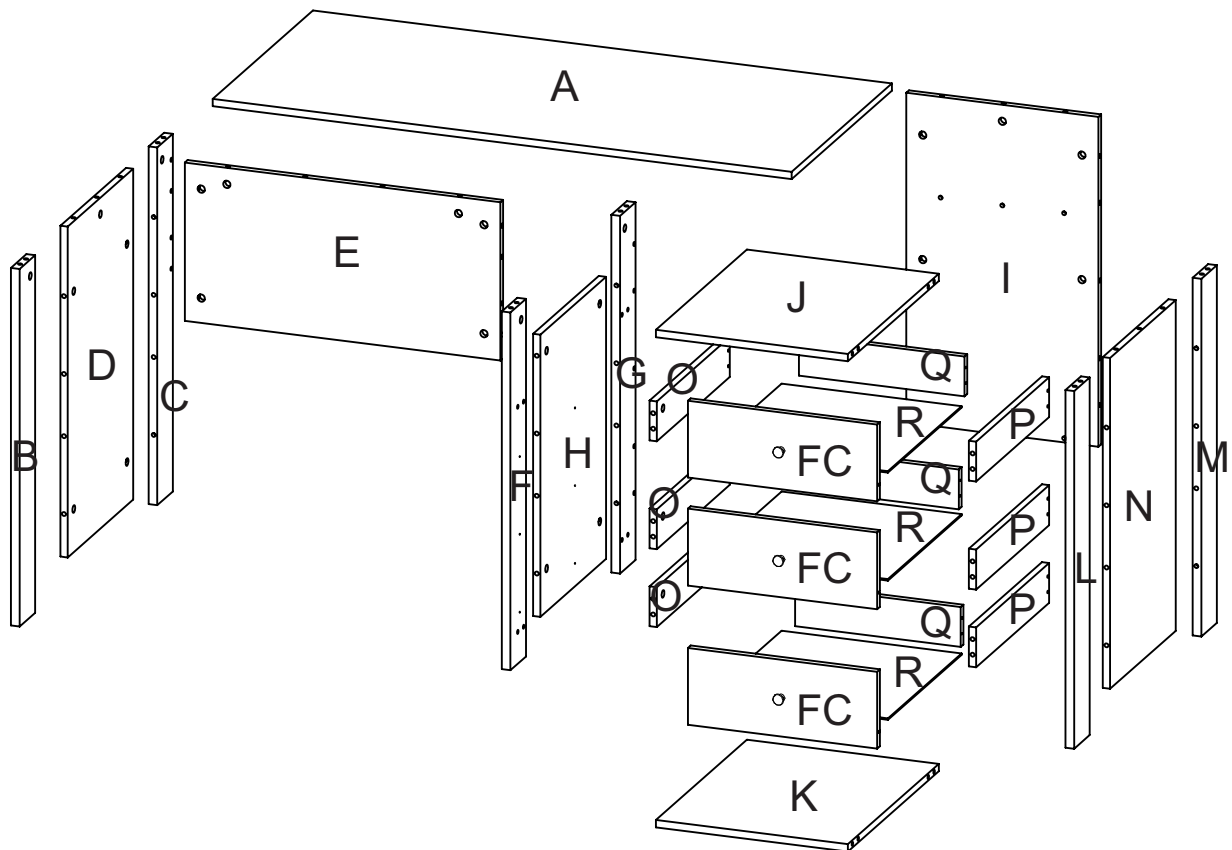

A - x1	F - x1	K - x1	O - x3
B - x1	G - x1	L - x1	P - x3
C - x1	H - x1	M - x1	Q - x3
D - x1	I - x1	N - x1	R - x3
E - x1	J - x1	FC - x3	

## MAX SUGGESTED LOADS

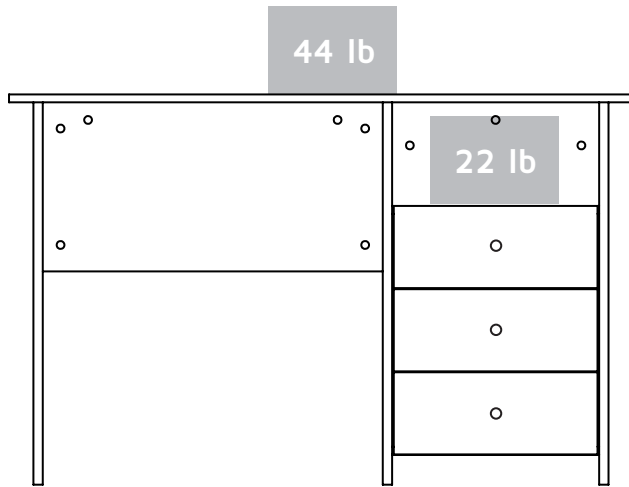

## CARGAS MÁXIMAS SUGERIDAS

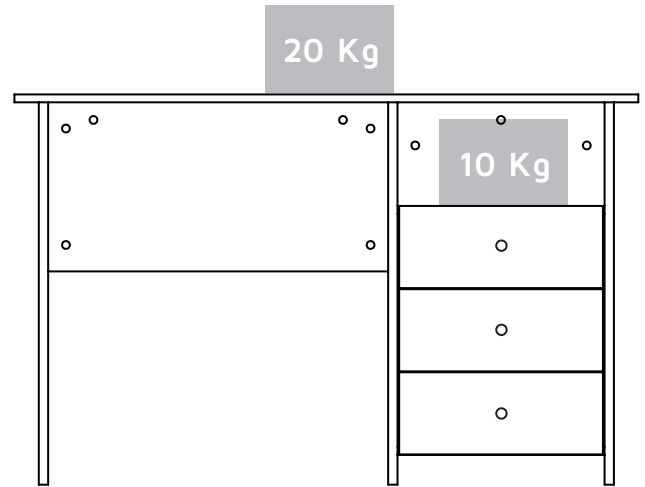

## ASSEMBLY RECOMMENDATIONS

Two people are recommended to assemble the product.

Assemble the cabinet on a flat, smooth surface, preferably on a carpeted floor or the carton box of the product.

Carefully read the assembly instructions and identify every wood and hardware part before start assembling the cabinet.

## RECOMENDACIONES DE ENSAMBLE

Ensamble el mueble entre dos personas.

Ensamble el mueble sobre una superficie plana y lisa, preferiblemente sobre un tapete o el cartón de la caja

Lea cuidadosamente las instrucciones e identifique todas las piezas y herrajes antes de empezar a armar el mueble.

1

SE RECOMIENDA ARMAR EL MUEBLE SOBRE LA CAJA O SOBRE UNA SUPERFICIE LISA, PARA NO RAYARLO / IT IS RECOMMENDED TO ASSEMBLE THE PRODUCT ON THE BOX OR ON A PLANE SURFACE FOR NOT SCRATCH IT.

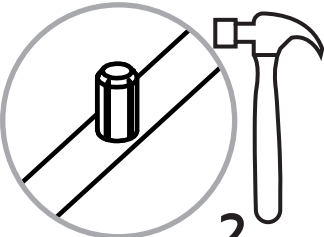
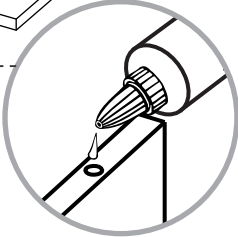
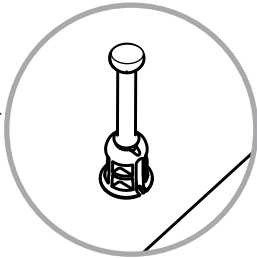
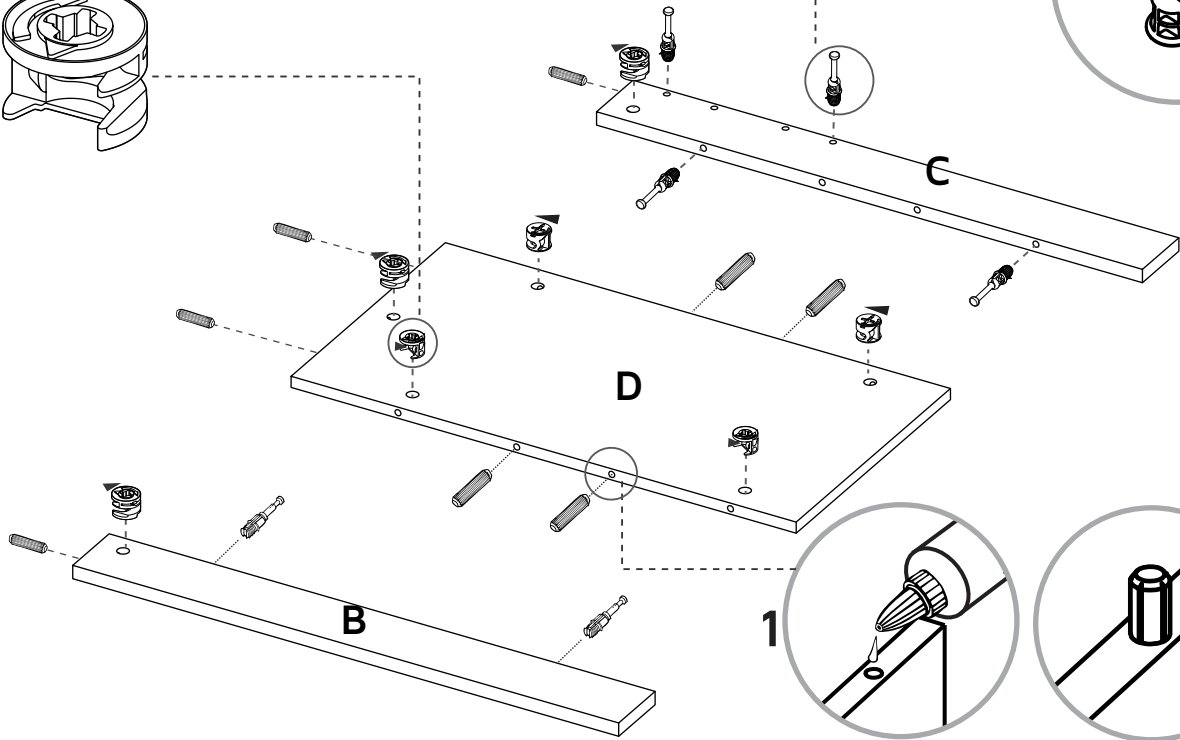
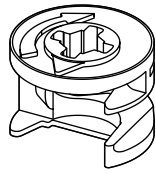

2

Aplice una gota de pegamento y golpee suavemente la pieza para ajustar el ensamble. Repita esto en todos los ensambles  
Gently hit the pieces with a rubber hammer to adjust the joint. Repeat this in the following steps.

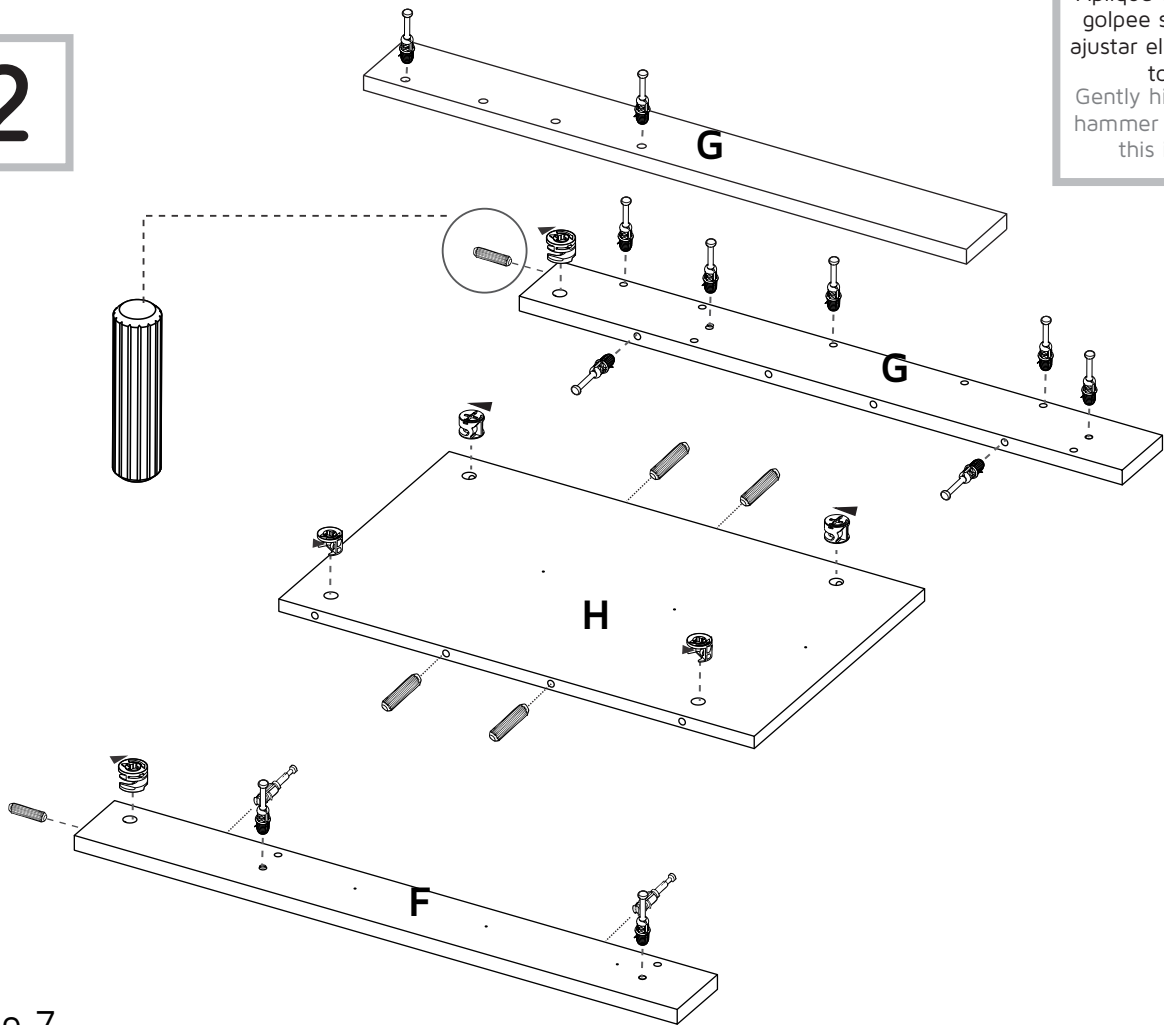

3

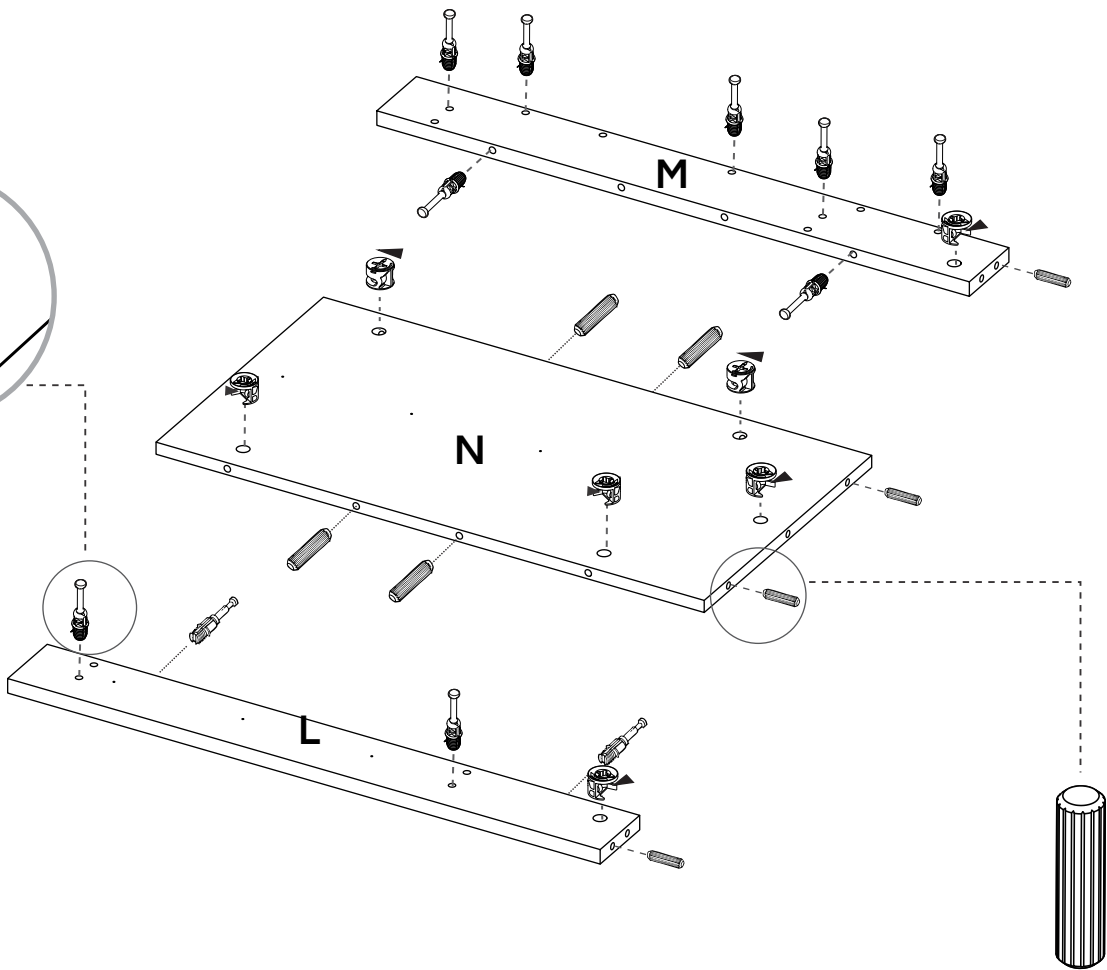
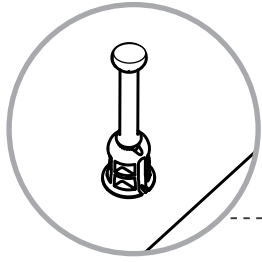

4

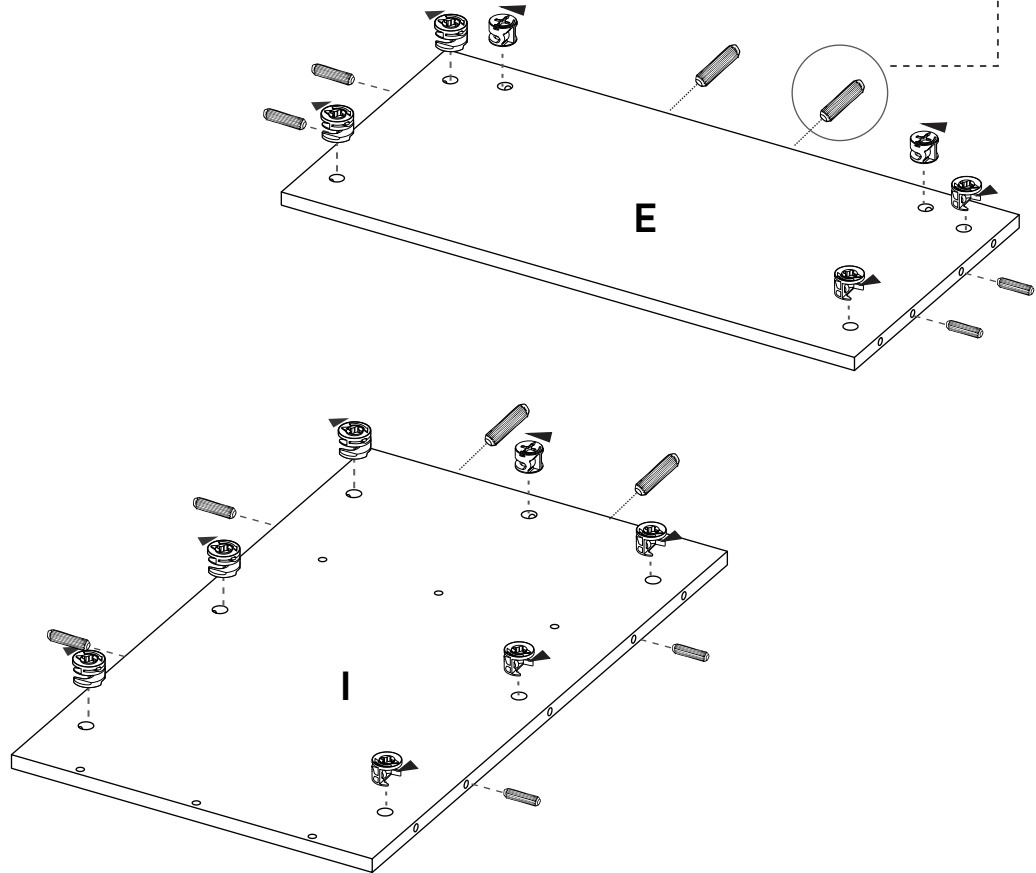

5

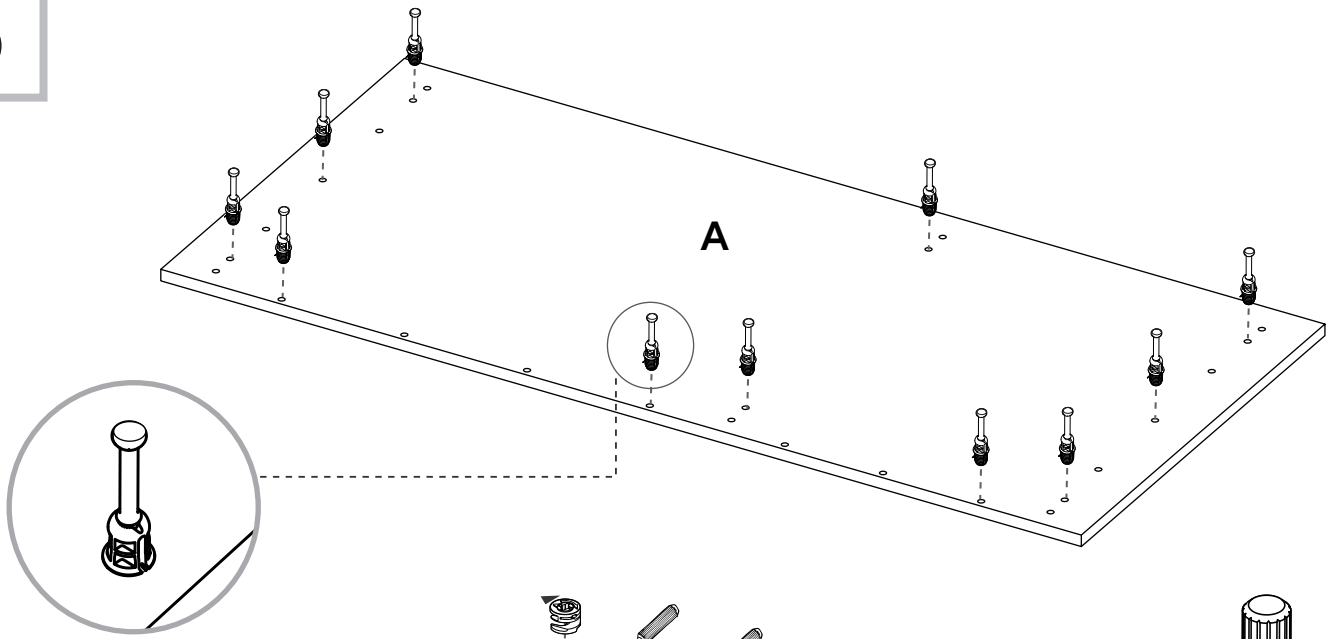

6

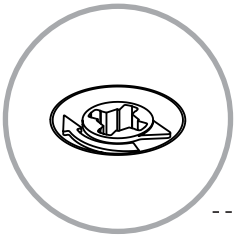
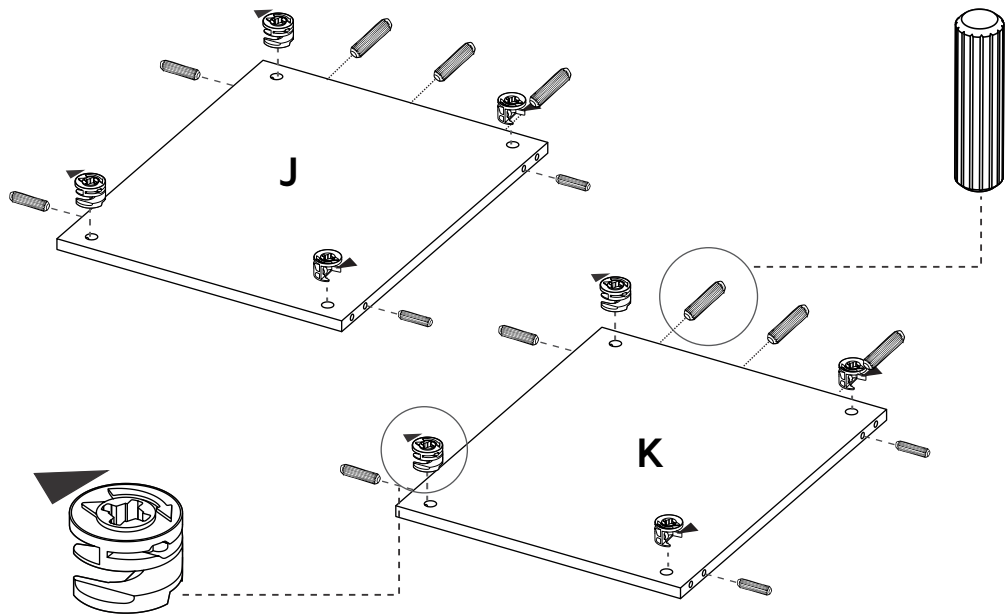

Gire las cajas minifix hacia la derecha para apretar las piezas.

Turn minifix cams to the right to tighten.

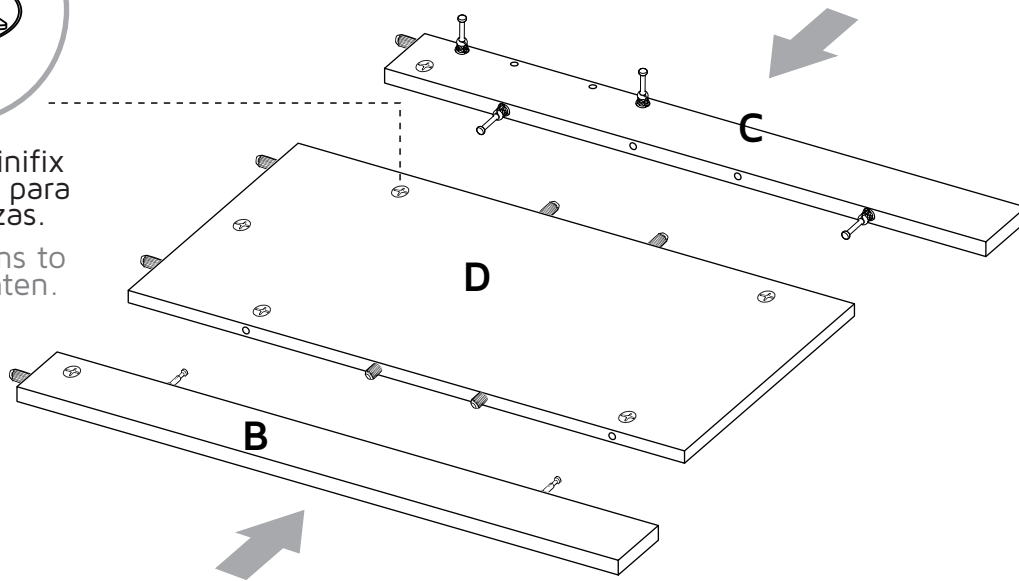

7

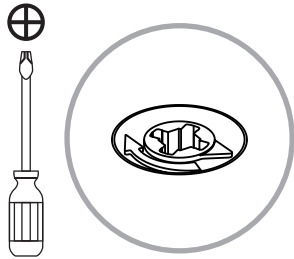

Gire las cajas minifix hacia la derecha para apretar las piezas.

Turn minifix cams to the right to tighten.

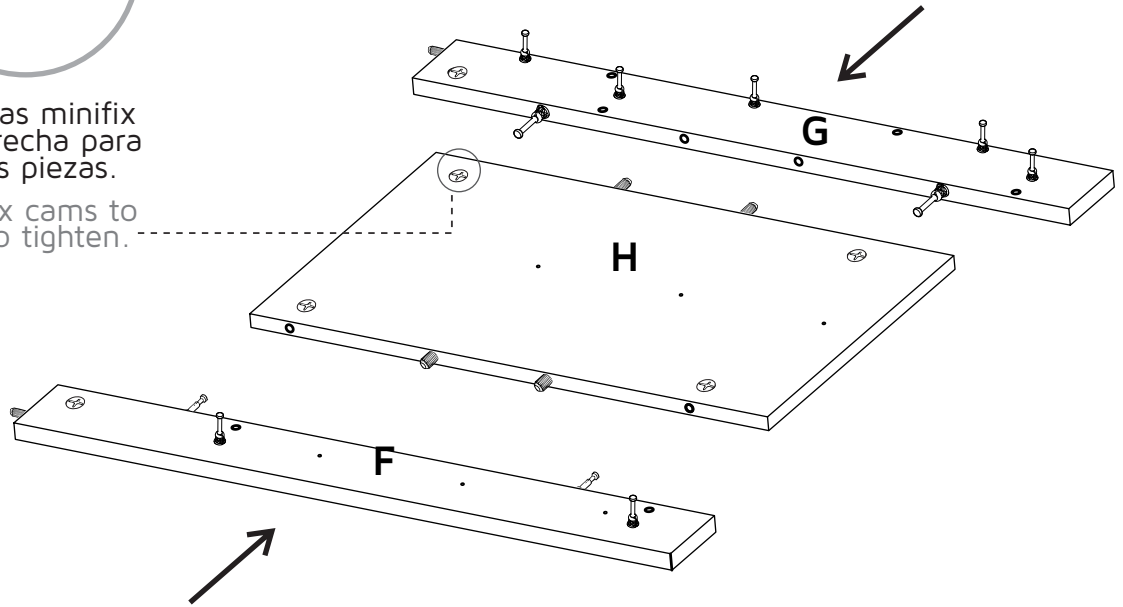

8

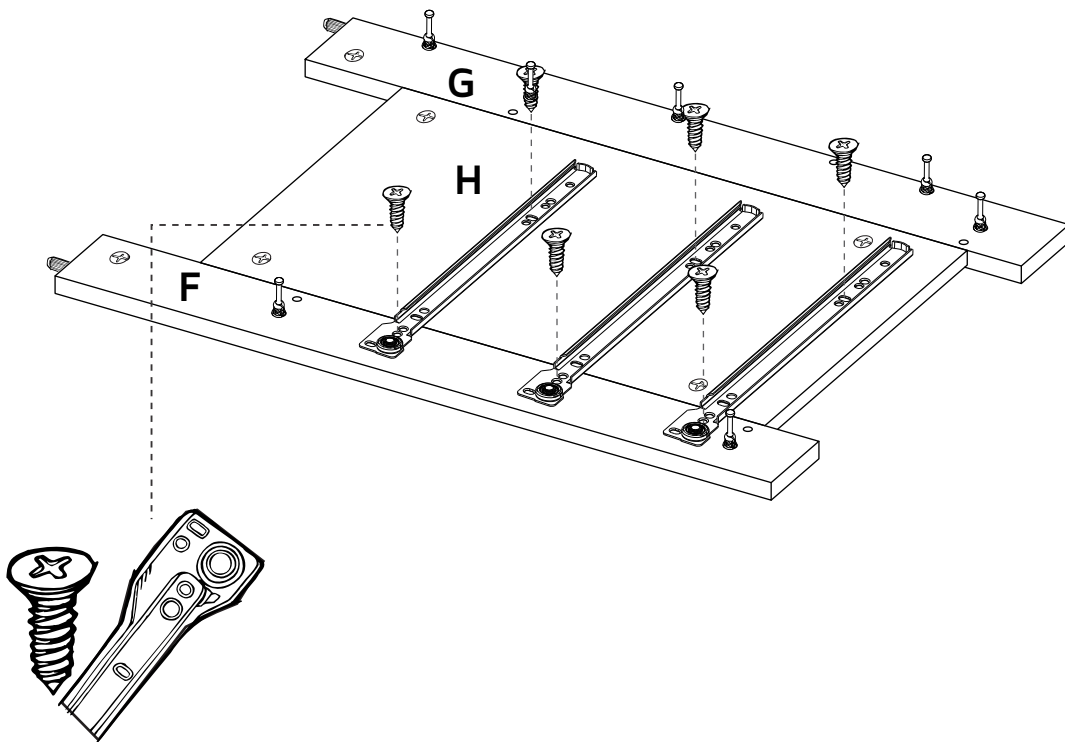

9



SE RECOMIENDA ARMAR EL MUEBLE  
ENTRE DOS PERSONAS /  
IT IS RECOMMENDED TO ASSEMBLE THE  
PRODUCT BETWEEN TWO PEOPLE

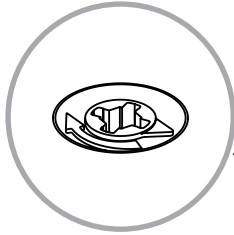

Gire las cajas minifix  
hacia la derecha para  
apretar las piezas.

Turn minifix cams to  
the right to tighten.

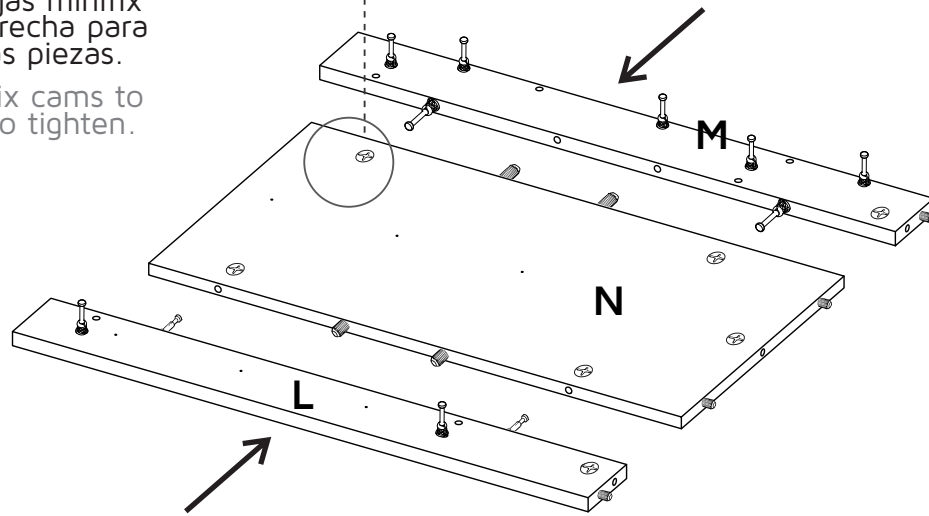

10

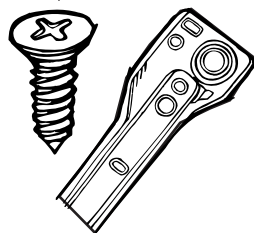
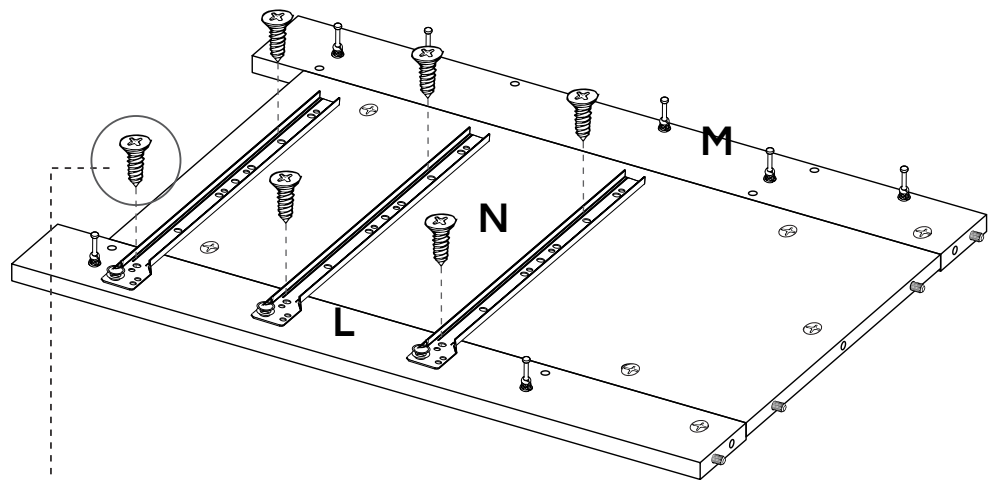

11

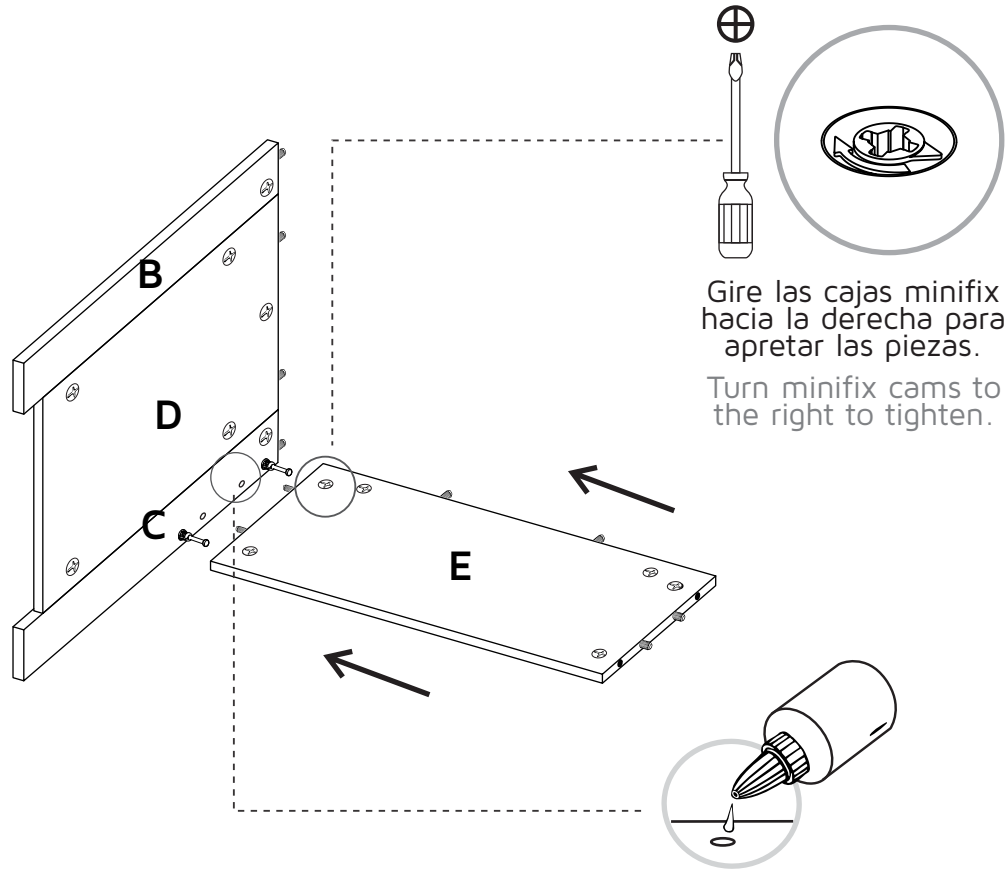

Gire las cajas minifix hacia la derecha para apretar las piezas.

Turn minifix cams to the right to tighten.

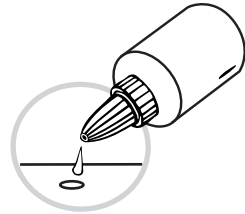

1 Gota x perforación/  
1 drop for drilling

12

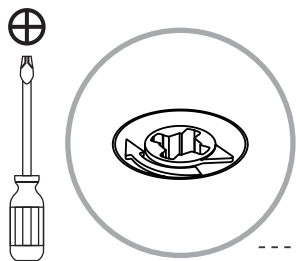

Gire las cajas minifix hacia la derecha para apretar las piezas.

Turn minifix cams to the right to tighten.

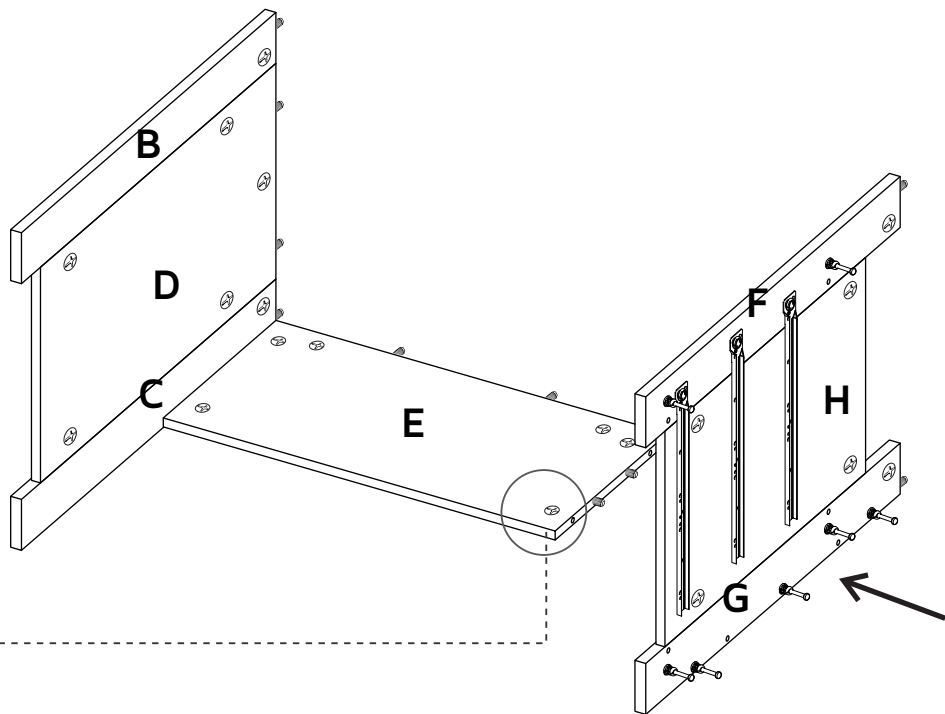

13

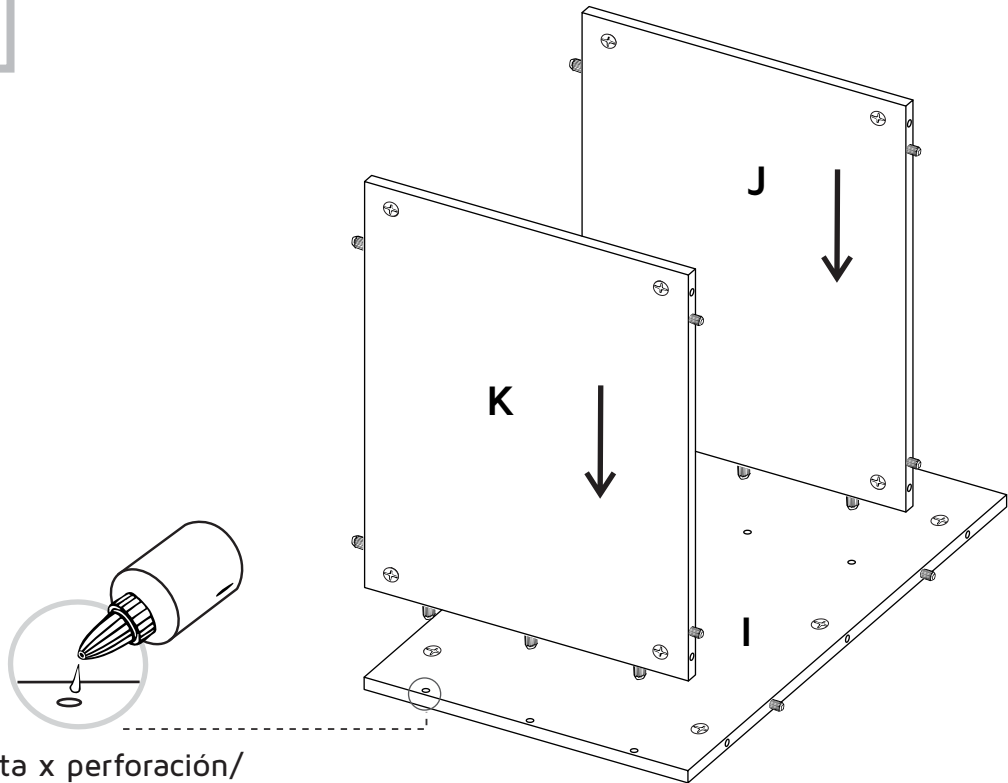

1 Gota x perforación/  
1 drop for drilling

14

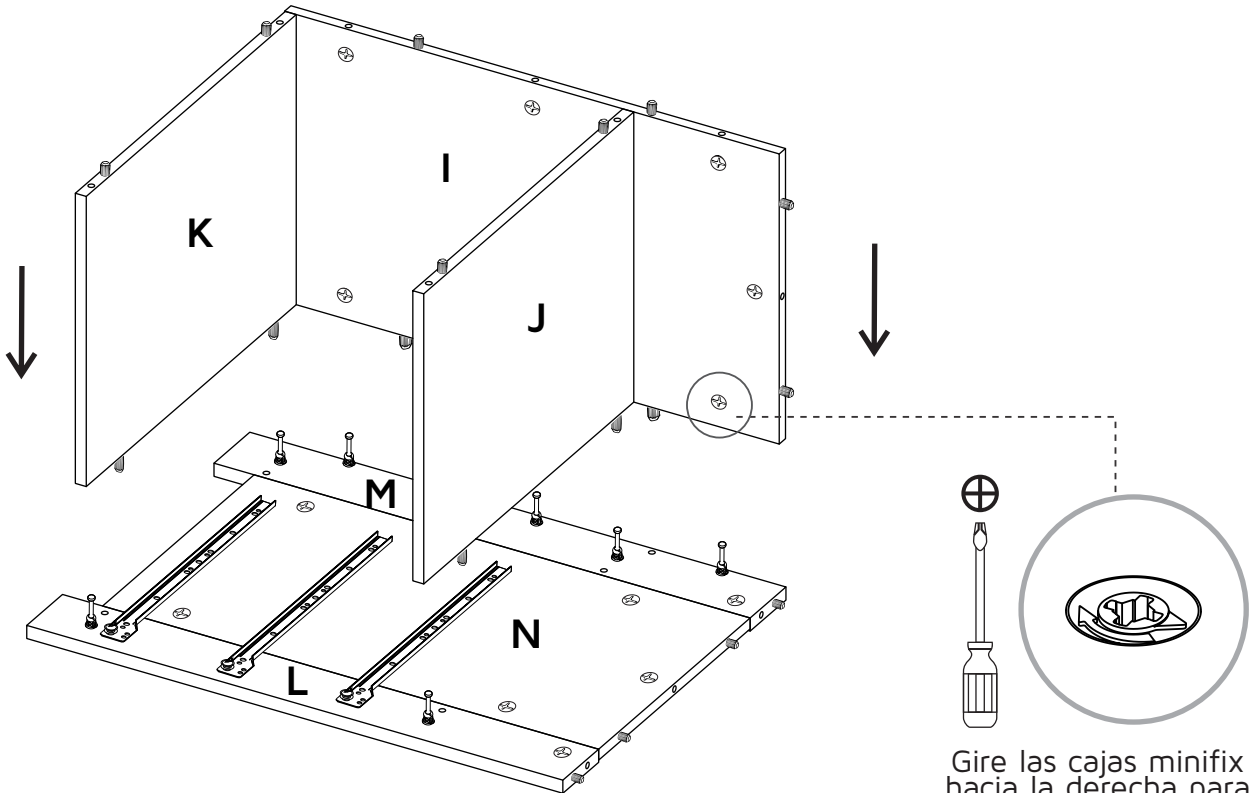

Gire las cajas minifix  
hacia la derecha para  
apretar las piezas.  
Turn minifix cams to  
the right to tighten.

15

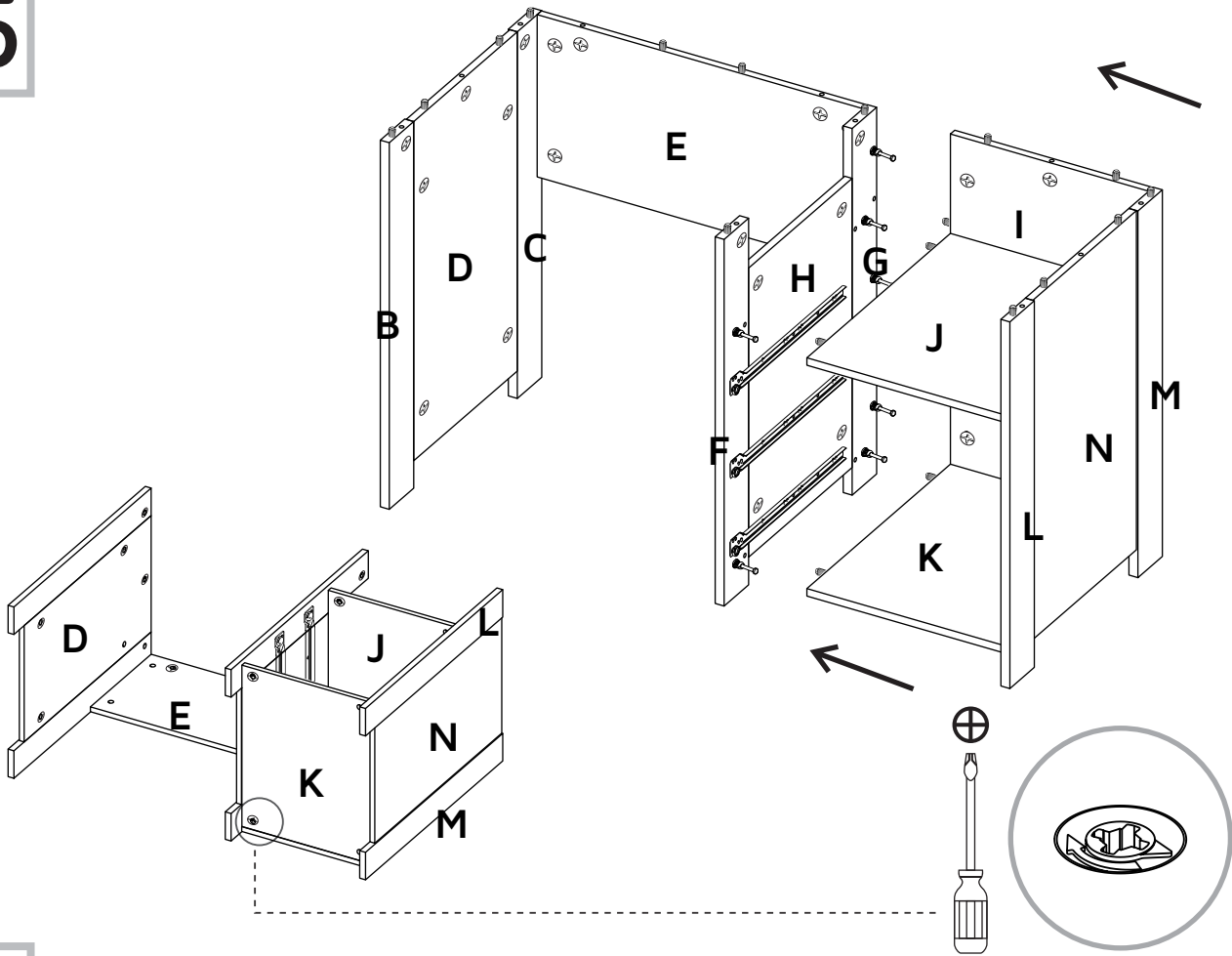

16

Gire las cajas minifix hacia la derecha para apretar las piezas.

Turn minifix cams to the right to tighten.

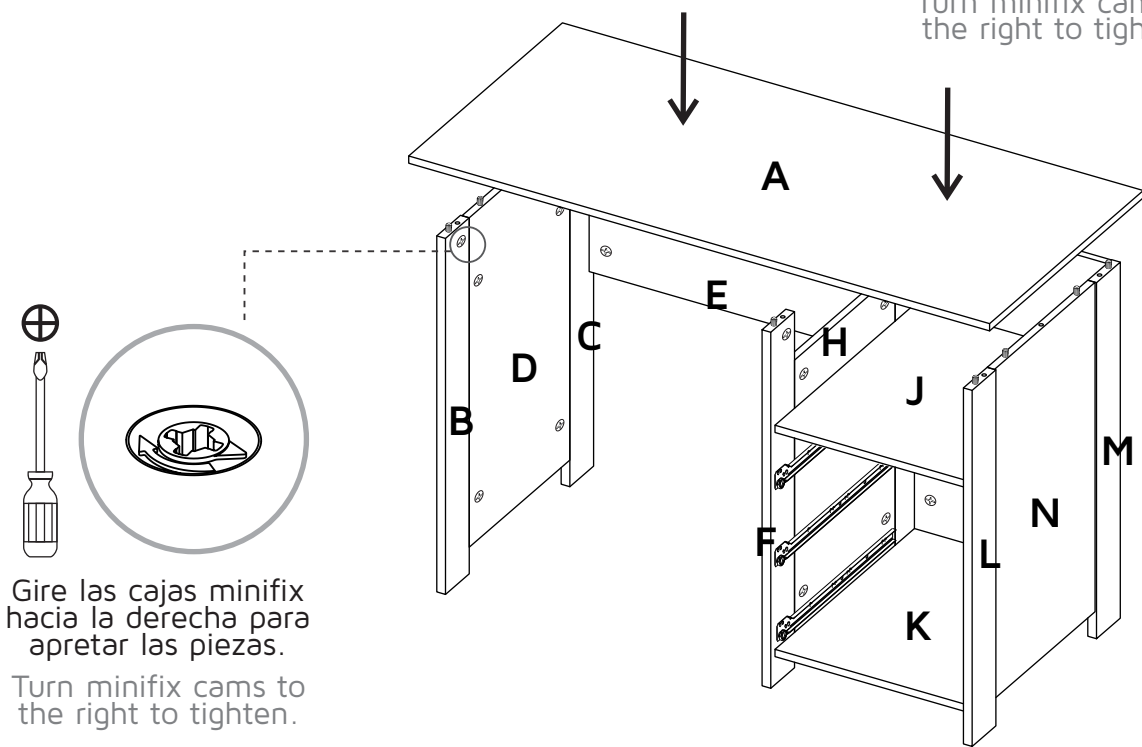

Gire las cajas minifix hacia la derecha para apretar las piezas.

Turn minifix cams to the right to tighten.

17

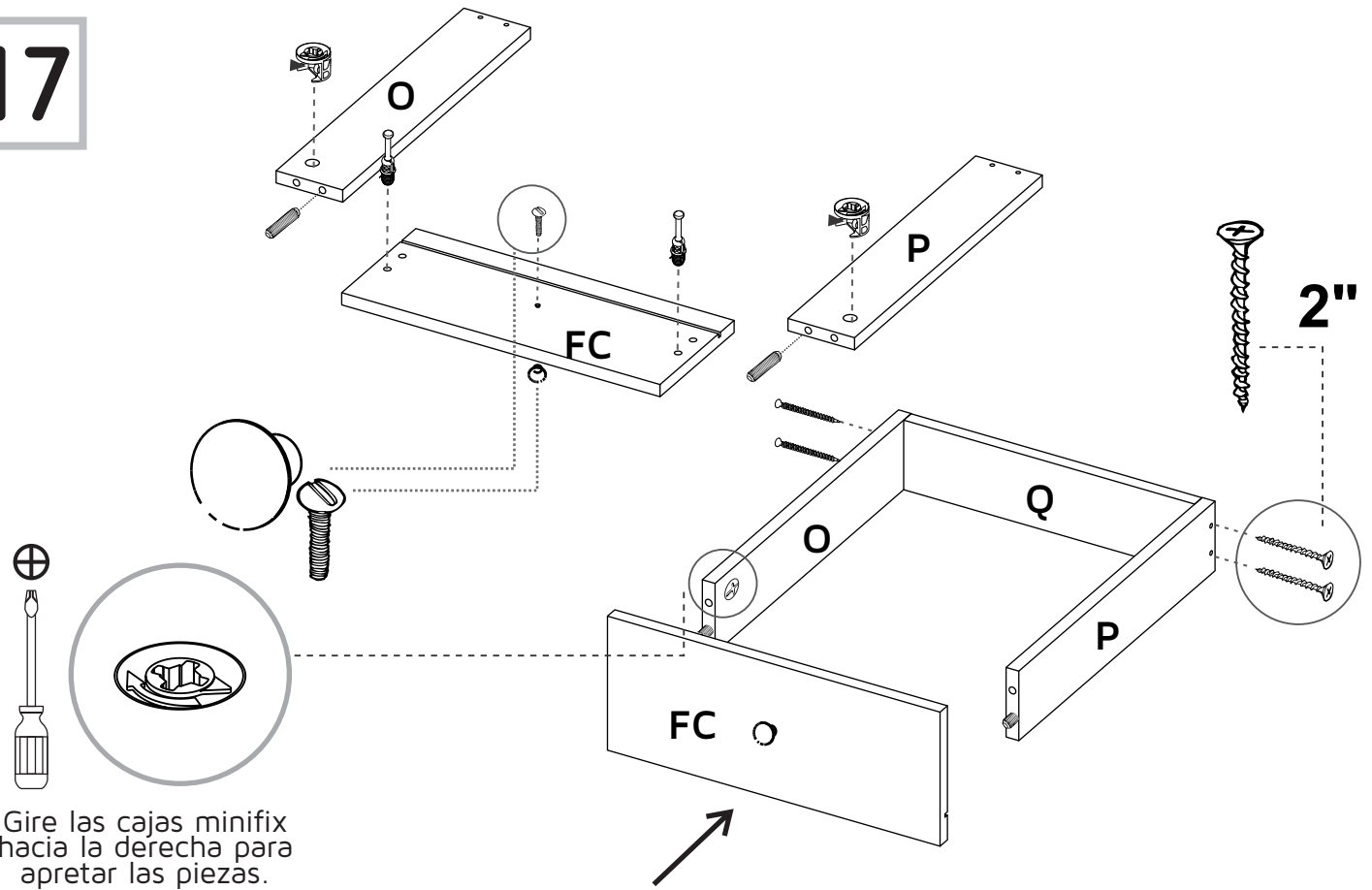

Gire las cajas minifix hacia la derecha para apretar las piezas.

Turn minifix cams to the right to tighten.

18

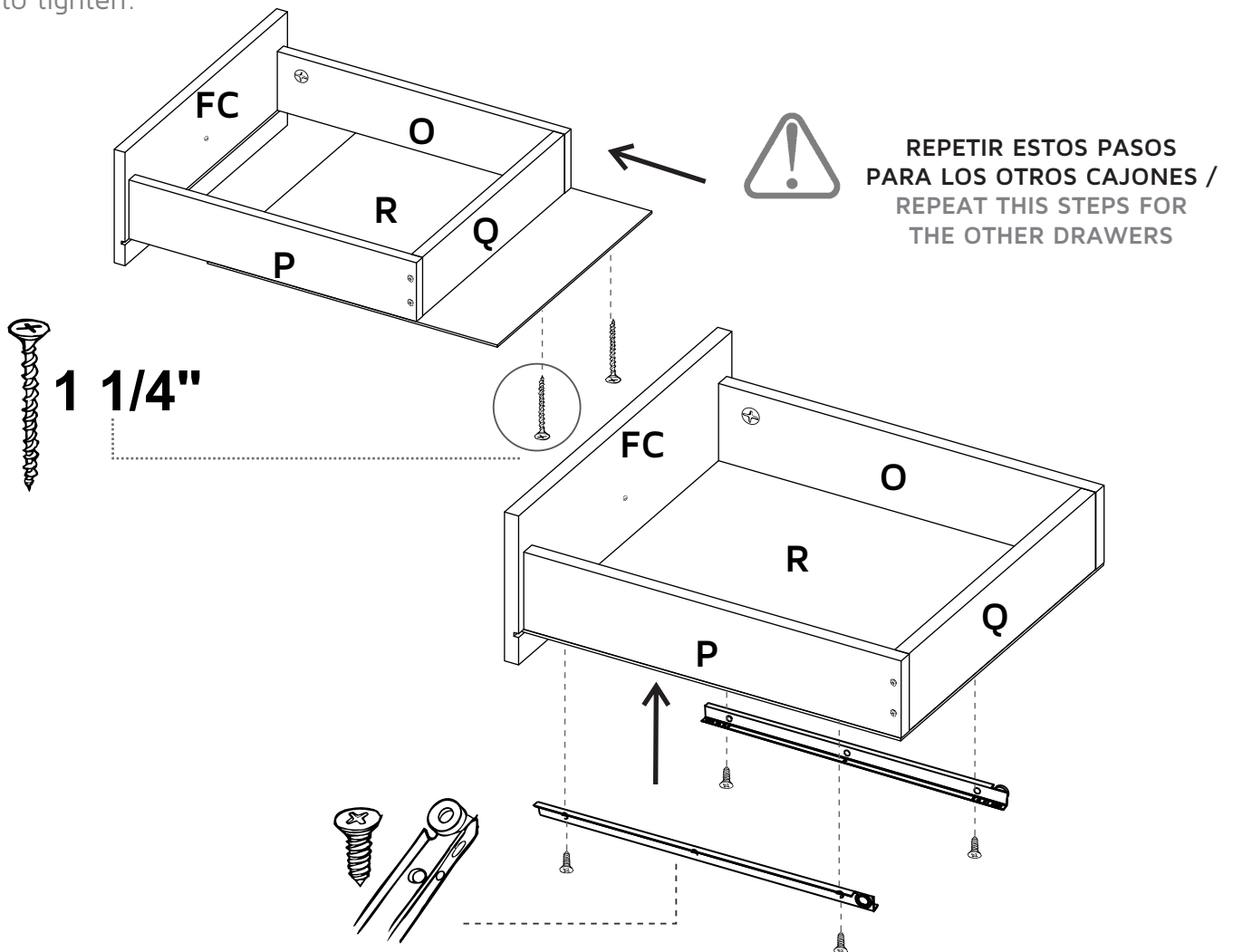

REPETIR ESTOS PASOS PARA LOS OTROS CAJONES / REPEAT THIS STEPS FOR THE OTHER DRAWERS

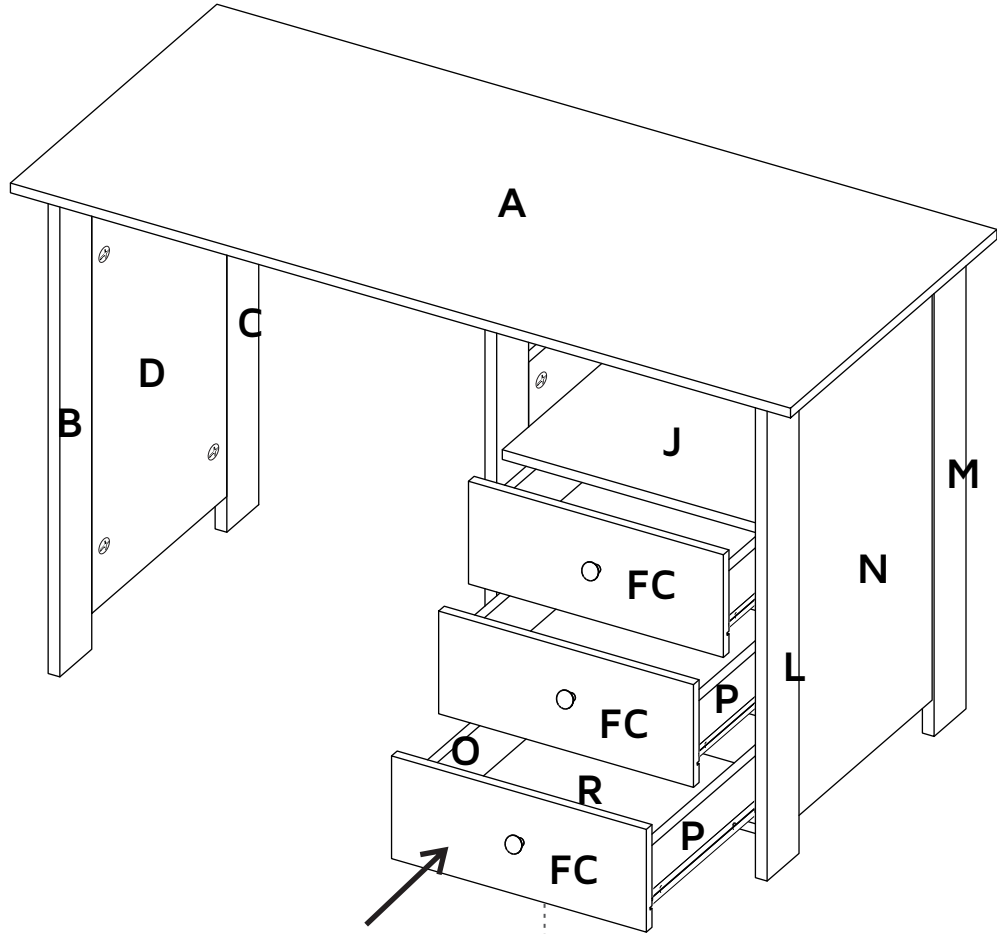

DESLICE LOS CAJONES  
DENTRO DEL MUEBLE /  
SLIDE THE DRAWERS  
INSIDE THE CABINET

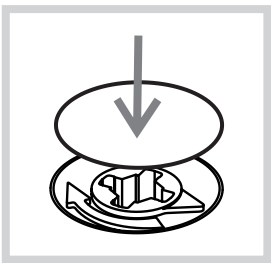

After you finish the adjustment  
of the cams, cover them with  
the cover caps.

Después de ajustar todas las  
cajas minifix, cúbralas con las  
tapas adhesivas.

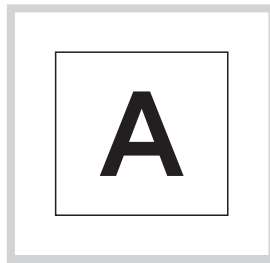

After you finish assembling the  
cabinet, take off the adhesive  
letters.

Al terminar de armar, despegue  
las letras adhesivas.

# WARRANTY POLICY

## PÓLIZA DE GARANTÍA

Furniture has a 3 year warranty coverage in wooden parts and 1 year warranty coverage in hardware pieces since its manufacturing date, which you can see in the lot number printed on the product box and the assembly instructions leaflet.

Warranty covers materials and workmanship imperfections which impair the assembly or correct functioning of the cabinet.

This warranty is not valid if the defects or imperfections are caused by the incorrect following of the assembly instructions, warnings and recommendations, misuse, intentional damage, fire or flood, or after modifications or any kind of alteration, or repaired by someone not authorized. When it's been assembled 3 months after the date of purchase. These defects MUST be reported before the warranty coverage period ends. Once the product has been assembled, the company will not be responsible for defective and/or damaged parts.

This warranty is ONLY valid for the ORIGINAL PURCHASER, it doesn't apply if the product has been resold, rented, etc.

We will take no liability for incidental or consequential damages caused to or by the product (This may not apply in your state).

To make this warranty valid you must write to our customer service email describing the product defect, lot number and submitting your sales receipt or proof of purchase, or contact us at our customer service line. Replaced parts will be under the product's original warranty coverage period. Damaged parts will become property of the company.

There are no other warranties applicable to this product.