

A few simple steps to ensure
perfect water, every time.



We're Here to Help



We are also available
for live video chat!

Call Us:

1.800.256.0695

Email Us:

support@avalonh2o.com

sales@avalonh2o.com

Live Chat:

Monday–Thursday: 9 a.m.–5:30 p.m.

Friday: 9 a.m.–4:30 p.m.

Let's Connect

Follow our social media accounts and stay up to
date on the latest Avalon news.



@avalon_h2o



Avalon Water Coolers



Avalonh2o

www.avalonh2o.com

Use and Care Guide

MODELS: A13 • A13BLK

Registration

Please visit the website below to register your new water cooler within the first 30 days of purchase. Registration within the first 30 days will activate your one year warranty.

www.avalonh2o.com/register-my-avalon-cooler

Please keep your model number, order number and purchase date for future support. You can reach us at 1-800-256-0695.

Model Number _____

Order Number _____

Purchase Date _____



The filtration of this product conforms to NSF/ANSI 42 and 53 for the reduction of Chlorine taste and odor, nominal particulate class 1, lead and cysts. (Listed as model Avalon A4FILTER & Avalon A5FILTER).

Conforms to NSF/ANSI 372

Contents

About Your Water Cooler

Meet Your Avalon Product	1-2
Part Names	3-4
Indicator Lights	5
Tech Specs	6
Filter Function Introduction	7

Getting Started

Unpacking	9
Installation (Under the Sink)	10-11
Installation (Refrigerator Water Line)	12
Flushing Filters	13-14
Finishing Water Cooler Installation	15-16
Activating Heating and Cooling	17
Installing and Removing the Drip Tray	18

User Guide and Maintenance

Dispensing Water	20
Replacing the Filters	21-23
Leak Detection	24

Cleaning

Activating Self-Cleaning Function	26
Rinsing, Cleaning, and Draining	27-29
Cleaning	30-31

Troubleshooting

33-34

Safety

36-37

Meet Your Avalon Product

Inside the box, you'll find:

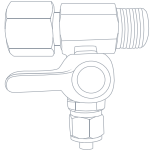

Metal Adapter with Valve
(3/8" compression)

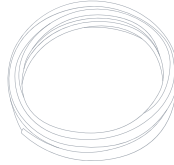

PE Tubing
(20' length, 1/4" diameter)



Filter Flushing Adapter



Carbon Block Filter



Sediment Filter

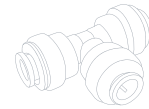

Three Way Plastic Adapter
(1/4")

Meet Your Avalon Product



Attractive Design

Attractive stainless steel design with sleek electronic illuminated buttons



Custom Temperature

Piping hot, cool, or crisp cold water



Dual Stage Filtration

Double the filtration for twice the peace of mind



Worry-Free Cleaning

Self-cleaning ozone function for longer lasting water purification



Built-in Nightlight

Makes late night water trips a breeze



NSF Certified Filters

We meet strict standards for public health protection



UL Listed

We design & manufacture with your safety in mind



Energy Star Approved

Saves the environment & your wallet



Child Safety Feature

Ensures safe hot water flow for the entire family

Part Names

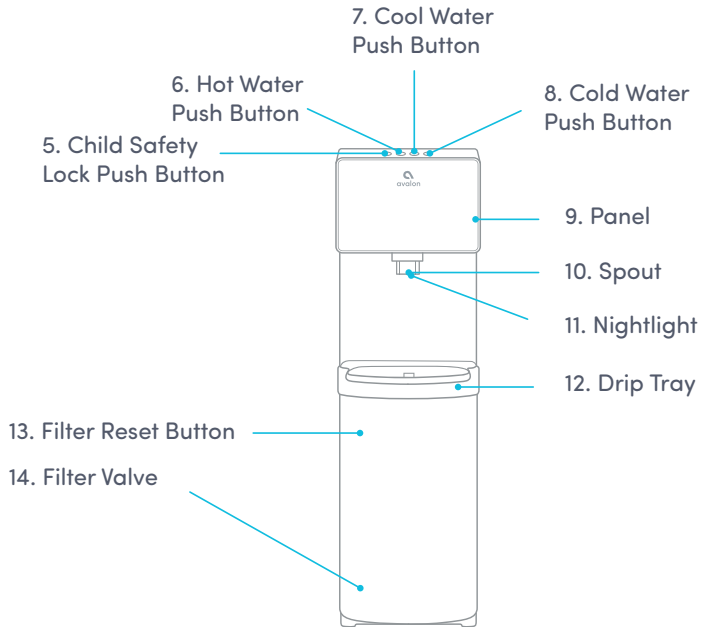
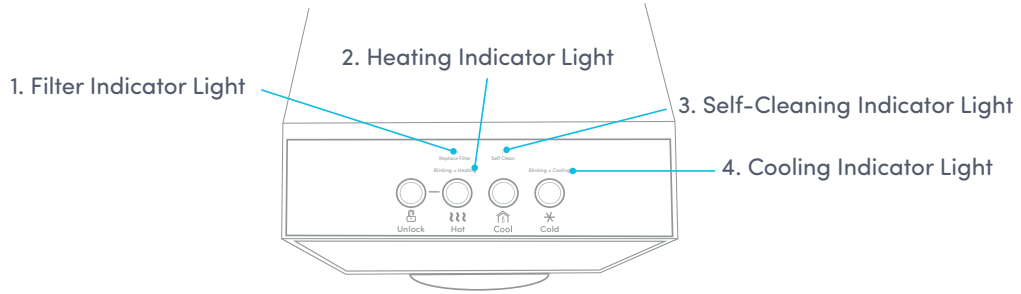

Part Names

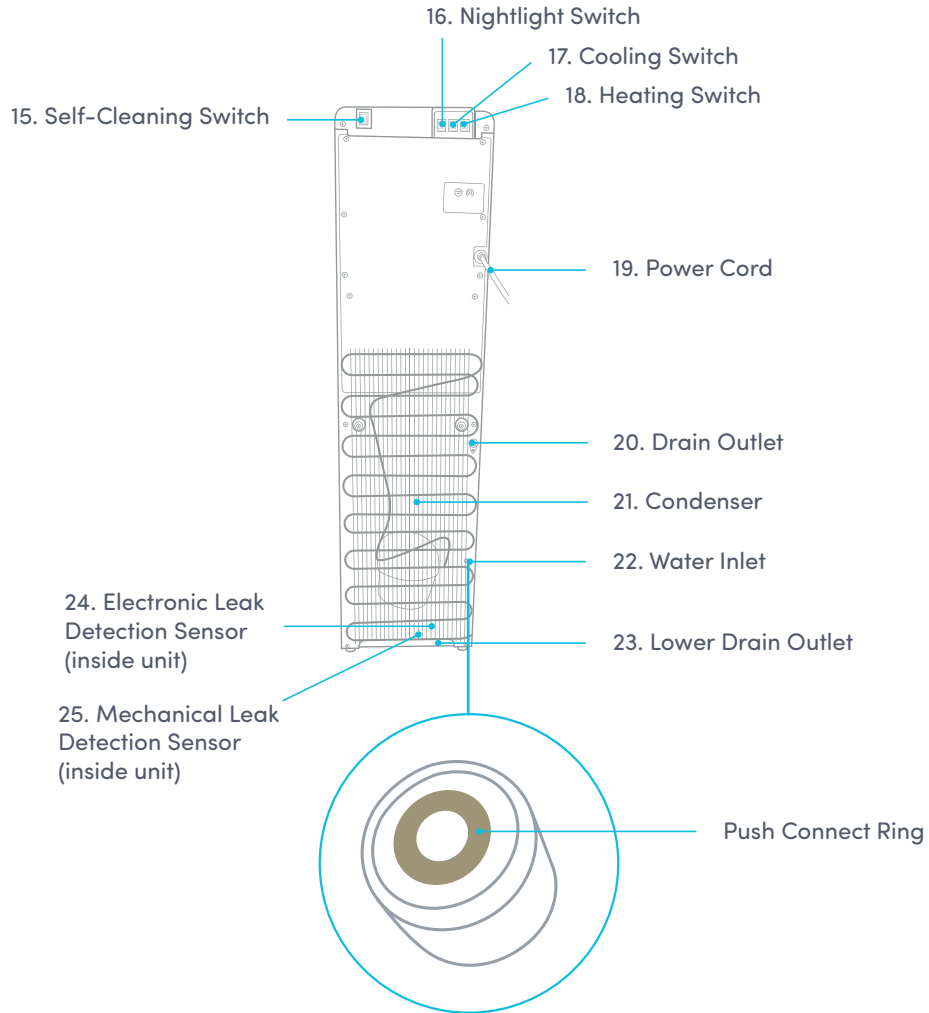

Indicator Lights

Heating	Heating Indicator Light This light will indicate when the water is heating. The light will blink while the water is heating and will turn off when it has reached the correct temperature of 185°F.
Cooling	Cooling Indicator Light This light will indicate when the water is cooling. The light will blink while the water is cooling and will turn off when it has reached the correct temperature of 47°F.
Replace Filter	Filter Indicator Light This light will be red when the filter needs to be replaced. This light will begin to blink red as a warning that the filter will need to be changed soon. When the life of the filter is expired this indicator light will remain steady on and the unit will beep to alert you that it needs to be changed right away.
Self Clean	Self-Cleaning Indicator Light This light will blink when the ozone cleaning function is activated.

Tech Specs

Model	A13 • A13BLK
Hot/Cold/Cool Output	1.8L/min / 2.2L/min / 2.0L/min
Hot Water Capacity	4 L/H (≥ 185°F)
Hot Tank Volume	1.16 Liters
Cold Water Capacity	2.5 L/H (≤ 50°F)
Cold Tank Volume	3.6 Liters
Applicable Water Pressure	0.1-0.4 MPa
Applicable Environment	39 ~ 104°F humidity ≤90%
Applicable Water	Tap Water TDS ≤ 350 ppm
Applicable Water Temperature	41 ~ 100.4°F
Stage 1 Filtration	Sediment
Stage 2 Filtration	Carbon Block
Product Size	13"(L)x12"(W)x41"(H)
Packing Size	16"(L)x15"(W)x45"(H)
Net Weight/Gross Weight	36.15 lb/46.5 lb
Voltage/Frequency	115V 60Hz
Cooling Method	Compressor
Heating Method	Internal Element
Heating Watts/Cooling Watts	420W/100W
Power Consumption	520W

This product is not recommended to be used at an altitude of above 1500 meters.

Filter Function Introduction

Stage	Filter	Function
Stage 1	Sediment Filter	Course filtration of raw water to remove rust, dirt and sediment
Stage 2	Carbon Block Filter	Removes the water odor, residual chlorine, organic matter, and lead to improve taste

Getting Started

Unpacking Your Avalon Water Cooler

Locating Dispenser

- Do NOT plug in the power cord yet.
- Place dispenser upright on a hard and level surface in a cool and shaded location near a grounded wall outlet. Position the dispenser so there is about 4 inches of clearance from the wall on the back and both sides.

Locating Accessories

- Unpack the product and install the drip tray by inserting it into place, see page 18.
- Take out the installation parts from inside the cabinet of the unit and follow the installation instructions below.

Installation (Under the Sink)

Installing the Metal Adapter with Valve

1. Turn off the current cold water supply that is the source of water to your sink.

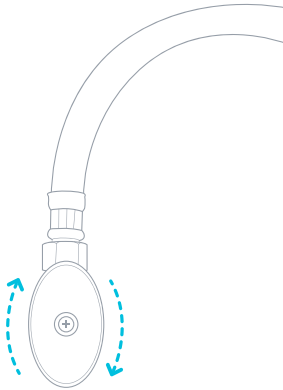

2. Disconnect the current cold water supply line under your sink.

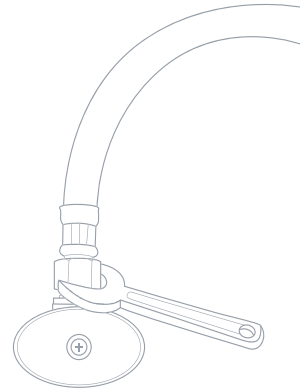

3. Connect the Metal Adapter with Valve between the cold water supply line and cold water valve.

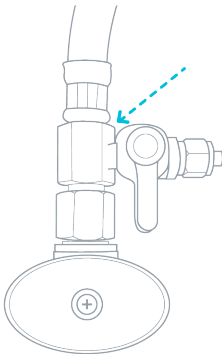

Installation (Under the Sink)

Installing the Metal Adapter with Valve

4. Remove the nut from the Metal Adapter with Valve and insert the PE Tubing through the nut. Slide the PE Tubing onto the protruding part of the Adapter where the nut was located until it reaches the threading.

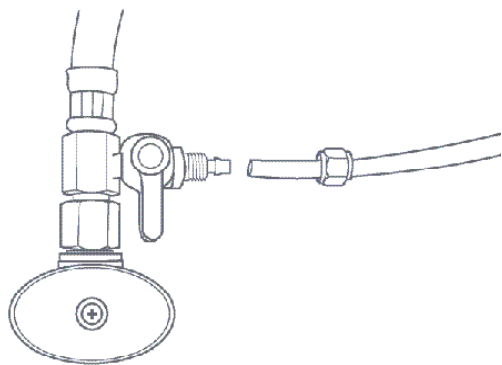

5. Screw the nut tightly into place to keep the PE Tubing securely connected to the Metal Adapter with Valve. Make sure the Valve is in the off position (perpendicular to the PE Tubing).

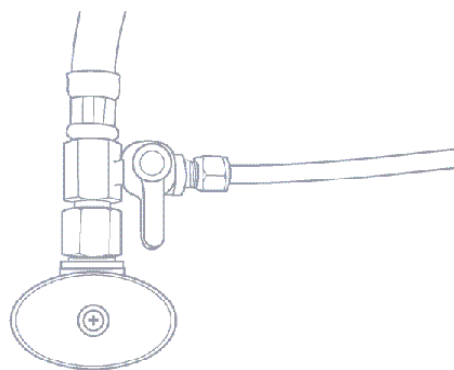

Installation (Refrigerator Water Line)

Installing the Three Way Plastic Adapter

1. Turn off the current cold water supply that is the source of water to your refrigerator line.

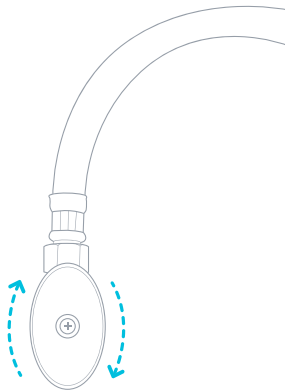

2. Cut the current 1/4" Tubing that is connected to the back of your refrigerator or ice maker near the end of it that is currently inserted into the refrigerator.

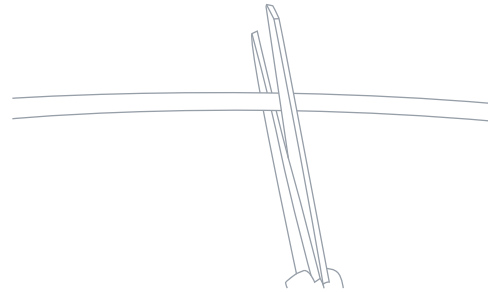

3. Insert each cut end of the existing 1/4" Tubing into one of the holes of the Three Way Plastic Adapter.

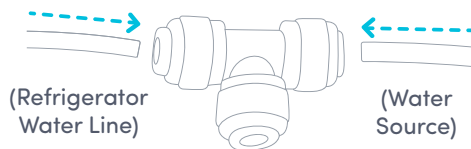

4. Insert one end of the PE Tubing that is supplied with the water cooler into the third opening of the Three Way Plastic Adapter.

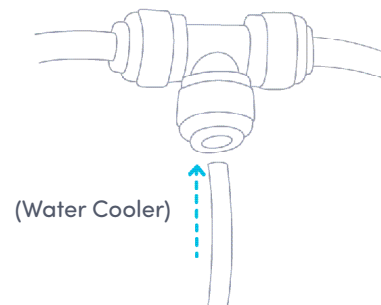

Flushing Filters Prior to Use

Before continuing with installation, it is recommended that you flush both filters for approximately 2 minutes.

1. Twist the filter into the provided Filter Flushing Adapter by rotating it clockwise.

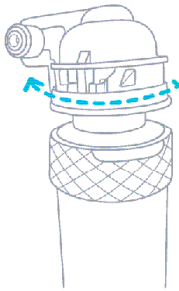

2. Take the open end of the PE Tubing that is now connected to your water supply and insert it into the left inlet hole on the Filter Flushing Adapter in the direction of the arrow.

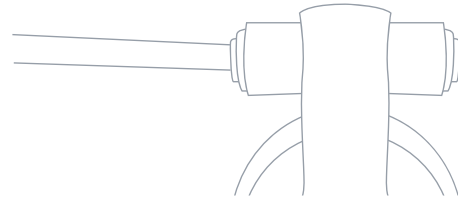

3. Hold the filter with the Filter Flushing Adapter in place over a sink. Turn the Valve of the Metal Adapter at the water source to the on position (the on position is parallel to the PE Tubing) and allow the water to flow through the Adapter and the filter for approximately 2 minutes to flush the new filter.

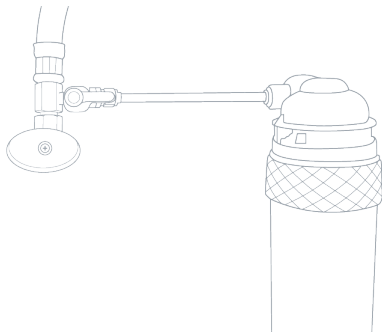

Flushing Filters Prior to Use

4. Turn the Valve of the Metal Adapter at the water source back to the off position, remove the filter from the Filter Flushing Adapter.

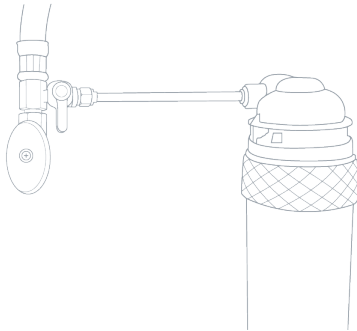

5. Remove the end of the PE Tubing from the Filter Flushing Adapter by pressing in on the push connect ring and pulling out the PE Tubing.

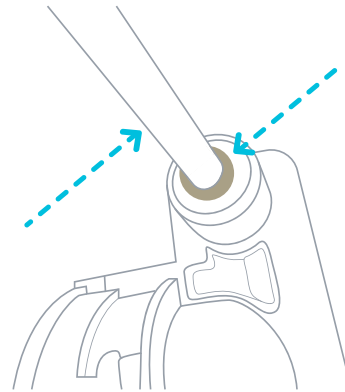

Repeat steps 1-5 for flushing the Carbon Block Filter.

Finishing the Water Cooler Installation

Once you have flushed the filters and removed the filters and PE Tubing from the Filter Flushing Adapter, you are ready to complete the installation process.

1. Remove the plug from the water inlet (#22) located on the back of the unit. To do this press on the push connect ring that is behind the plug. Push the open end of the PE Tubing into the water inlet (#22). Make sure the PE Tubing is tight and secure.

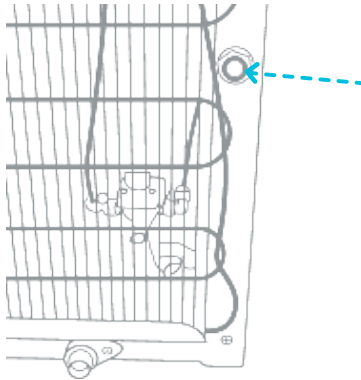

2. Open the cabinet door of the unit. Twist the filters into the filter heads in the cabinet by rotating them clockwise. The Sediment Filter should be on the left and the Carbon Block Filter should be on the right.

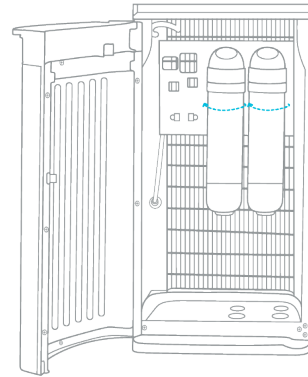

3. Turn the Valve for the water source back on (the on position is parallel to the PE Tubing).

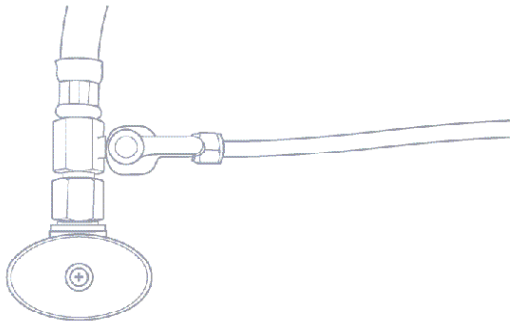

Finishing the Water Cooler Installation

4. Turn on the Valve that is located to the left of the filters inside of the cabinet (the on position is parallel to the PE Tubing).

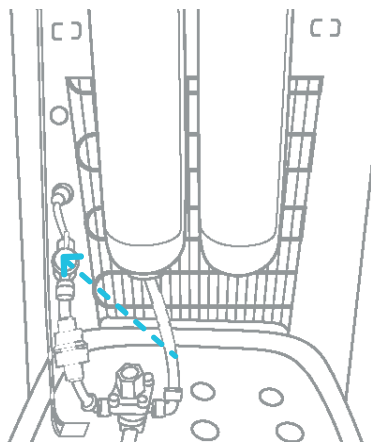

5. After installation of the water line and filter is complete, plug the power cord into a grounded wall outlet and begin to use the machine. Please allow the machine about 10-15 minutes for the water to fill in the tanks before use. Continue on for instructions on usage.

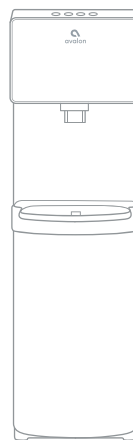

10-15
min

Activate Heating and Cooling

Before turning on the heating (#18) or cooling (#17) switches, ensure water is already filling inside the inner tanks by dispensing a drop of water from the hot (#6) and cold (#8) push buttons.

To activate the cold water, push the cooling switch (#17) into the on (I) position by pushing the top of the switch in. If you do not wish to have cold water you can leave the switch in the off (O) position.

To activate the hot water, push the heating switch (#18) into the on (I) position by pushing the top of the switch in. If you do not wish to have hot water you can leave the switch in the off (O) position.

Please allow 15 minutes for the hot water to be heated. During this time the heating indicator light (#2) will be steady. The light will turn off when the heating process is complete. Please allow 1 hour for the cold water to be cooled. During this time the cooling indicator light (#4) will be steady. The light will be turned off (O) when the cooling process is complete. If any error occurs in the heating or cooling process, the indicator light will blink.

Installing and Removing the Drip Tray

No external drain is needed, the overflow will collect here. The red float will rise to indicate when the drip tray needs to be emptied.

1. To install the drip tray, simply slide it into the area at the top of the door until it snaps into place.

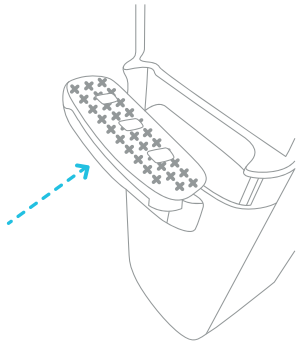

2. To remove the drip tray, place your fingers in the grid of the drip tray with one hand and hold the door of the cooler shut with the other.

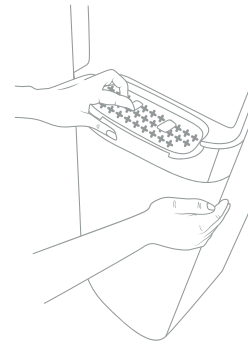

3. Gently pull the drip tray toward you to release it. Once it has been released you can remove the drip tray from the door of the cooler to empty it.

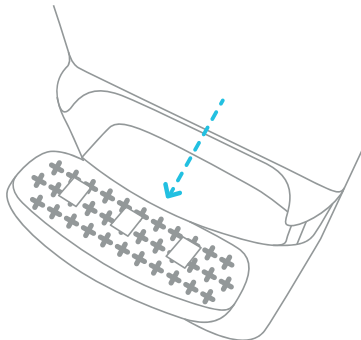

User Guide and Maintenance

Dispensing Water

Cold Water

Once you have turned the cooling switch (#17) into the on (I) position it will take initially 1 hour for the water to cool. During this time the cooling indicator light (#4) around the cold water button will blink. During this time the compressor could run continuously. This is normal. The light will be turned off when the cooling process is complete.

1. Position a bottle, glass, pitcher or cooking pot below the water spout (#10).
2. Press the cold water button (#8) to begin the flow of water. You must continue to press the cold water button in order for the water to continue to flow. While water is dispensing, the button will light up blue.
3. Once the desired fill level is achieved, release the cold water button (#8) to stop the flow of water.

Cool Water

1. Position the bottle, glass, pitcher or cooking pot below the water spout (#10).
2. Press the cool water button (#7) to begin the flow of water. You must continue to press the cool water button in order for the water to continue to flow. While water is dispensing, the button will light up orange.
3. Once the desired fill level is achieved release the cool water push button (#7) to stop the flow of water.

Hot Water

Once you have turned the heating switch (#18) into the on (I) position it will take initially 15 – 20 minutes for the water to heat up. During this time the heating indicator light (#2) above the hot water icon will be steady. The light will be turned off when the heating process is complete.

1. Position a bottle, glass, pitcher or cooking pot below the water spout (#10).
2. Press the child safety lock push button (#5) and press the hot water button (#6) to begin the flow of water. You must continue to press the hot water button in order for the water to continue to flow. While water is dispensing, the button will light up red.
3. Once the desired fill level is achieved release the hot water push button (#6) to stop the flow of water.

Replacing the Filters

1. When lifetime of the filter is near its end, either by means of water flow or by means of 6 months time, the filter indicator light (#1) on the left side of the front panel will blink red as a warning. When the filter lifetime is up, the indicator light will be steady red and the machine will beep to let you know that the filter needs to be changed.



2. Shut off the Valve located at the connection to the water source or the Filter Valve (#14) located to the left of the filters inside of the cabinet.

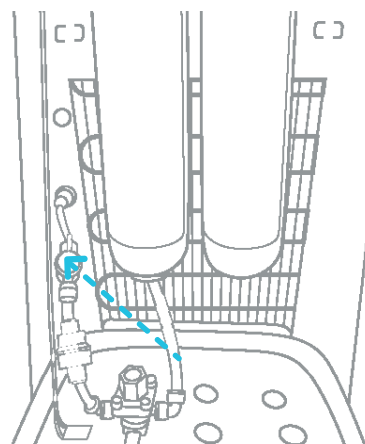

Replacing the Filters

3. Twist the expired filters to remove them. Insert the new filters into the Filter Adapters by twisting them into place and rotating them clockwise.

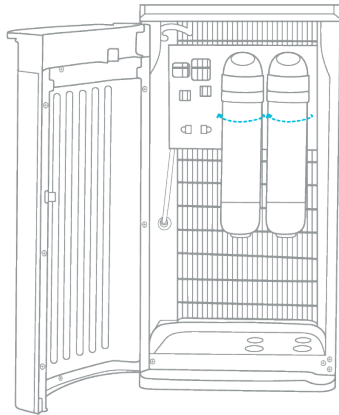

4. Turn on the Valve that was previously shut off. This Valve will be located at the connection to the water source or located to the left of the Sediment Filter.

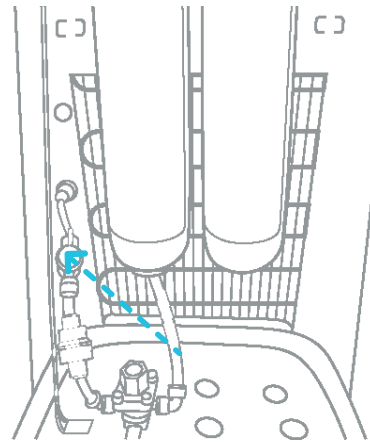

Replacing the Filters

5. After replacing the filters, press and hold the Filter Reset Button (#13) located on the upper left side of the cabinet. Press and hold this button until the filter indicator light (#1) turns off.

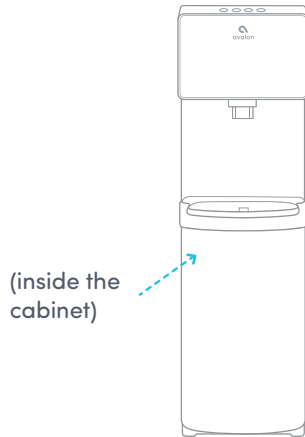

6. In order to flush the new filters, follow the instructions on page 13 or allow the water to flow from the water spout (#10) for approximately 2 minutes until there is a flow of clear water.

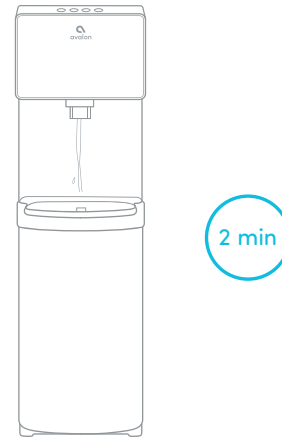

Leak Detection

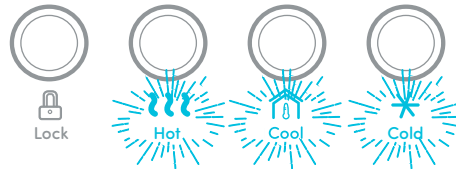

Our machines are equipped with a high-tech dual leak detection system that will alert you of any potential leak. At the same time the machine will automatically shut off any intake of water to prevent a potential flood. In the event of a possible leak, the hot water push button (#6), cool water push button (#7), and cold water push button (#8) will start blinking and a beep will sound. Please check around the machine for any leaking water and determine the source of it. If you find the source of the leak, you can call our support line for assistance in fixing it. If you do not find the source of this leak, it may have been caused by accidental spillage of water or from a filter change. Unplug the water cooler and turn off the valve to the left of the filters (#14) (as shown in picture 1). Locate the electronic leak detection sensor in the lower back left corner of the cabinet (#24) as well as the mechanical leak detection sensor (#25) (as shown in picture 2) and ensure the area around the sensors is completely dry including the notch. If there is excess water pooled in the notch, you can drain this water by unscrewing and removing the lower drain outlet cover (#23) on the lower back of the unit (as shown in picture 3).

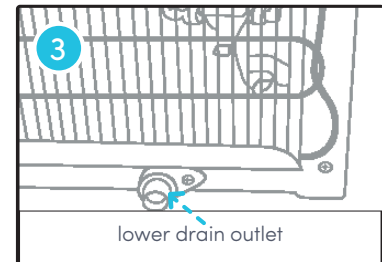
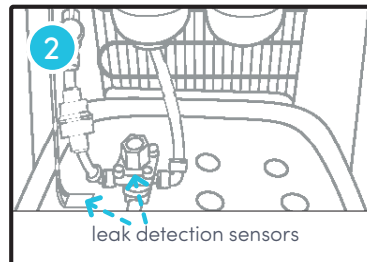
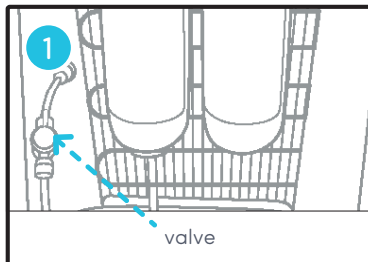

Leak Detection

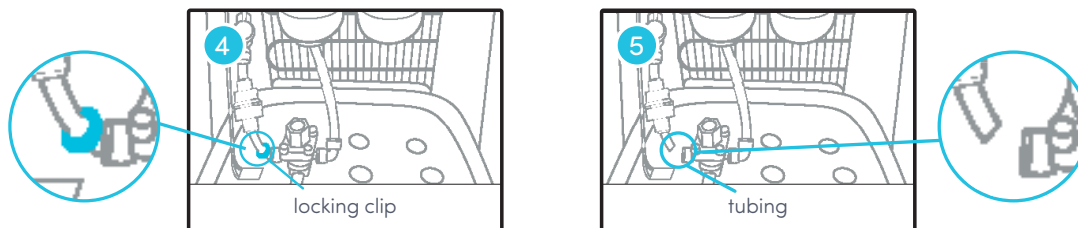

Once the area and sensors are dry, you will need to release the water pressure from the mechanical leak detection sensor (#25). This can be done by removing the locking clip on the left side of the mechanical leak detection sensor (as shown in picture 4). Next you will need to remove the tubing that leads into the left side of the mechanical leak detection sensor (as shown in picture 5) by pressing in on the push connect ring. Keep a paper towel handy while doing this as some water may drip from the open tubing. Push the tubing back into place and put the locking ring back on. The beeping and blinking lights will stop, and the machine will be ready to use as normal again.

If you still seem to have an issue after following these steps, contact our customer support for further assistance.

Cleaning

Activating Self-Cleaning Function

It is recommended that the self-cleaning feature is used once a week to sanitize the tanks and water lines.

1. To activate, press the self-cleaning switch (#15) and hold in the on position for 5 seconds and release. The switch will immediately go back into the off position.
2. The self-cleaning indicator light (#3) will begin to blink. This indicates the self-cleaning cycle is underway.
3. Ozone will be produced and injected into the water system, it will kill bacteria and bio-films typically found in water dispensers. By the end of the cleaning cycle the ozone will convert into harmless oxygen and will be emitted into the air.
4. When the self-cleaning cycle is complete the self-cleaning indicator light (#3) will stop blinking and will be steady.

Please Note: This self-cleaning cycle will take 90 minutes to complete. During this time do not dispense and drink the water. We recommend you do this during a period of time when the unit will not be in use for example overnight. During the cycle you may smell some of the ozone, this is normal.

Rinsing, Cleaning, and Draining

To prolong the lifetime of the machine, it is recommended that the unit be cleaned and sanitized manually about every six months.

To clean the outside of the unit

Use a disinfectant of your choice to wipe down the outside of the machine. Disinfectant does not come with this unit. It can be purchased separately from a local store.

To rinse the inside of the unit

The machine has been disinfected prior to departing from the factory. However, it is recommended to rinse and drain the unit prior to installation.

1. Before cleaning, make sure that the cooling switch (#17) and heating switch (#18) are in the off (O) position and unplug the machine.

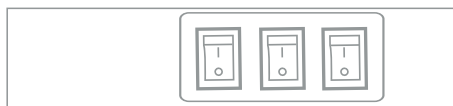

2. Remove the two screws located on the back (at the top, in line with the switches) of the cooler. Remove the top cover by lifting at an angle and pull off. Remove the white cold water tank cover and the separator.

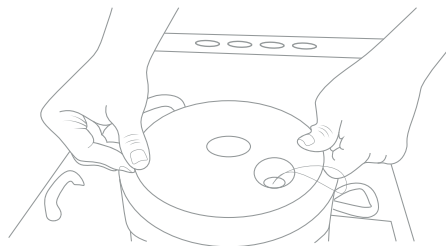
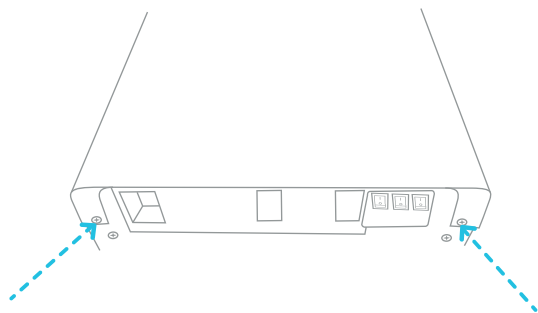

Rinsing, Cleaning, and Draining

3. Pour 0.6 gallons of clean water into the cold tank. (The cold water tank is the open cylinder that the white cover was removed from).

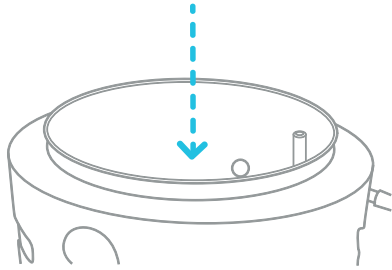

4. Place a large bucket beneath the drain outlet (#20) located on the back of the unit. Remove the drain cover and allow the water to drain from the unit. Water will start flowing as soon as the drain cover is removed.

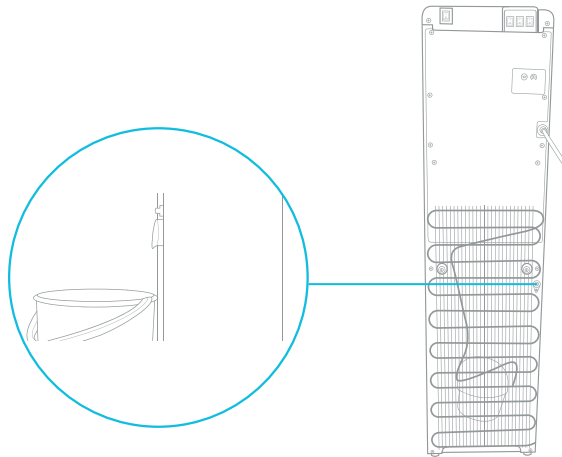

Caution: The dispenser will heat water to a temperature of approximately 185°F. It can cause severe burns if not handled carefully. Please use caution while operating and cleaning. Please allow ample time for any hot water inside the machine to cool down before draining it.

Rinsing, Cleaning, and Draining

5. Once water is completely drained, reposition the drain cover, cold tank cover and the top cover. Ensure that the pipes and wires are connected properly and you may use the dispenser as normal.

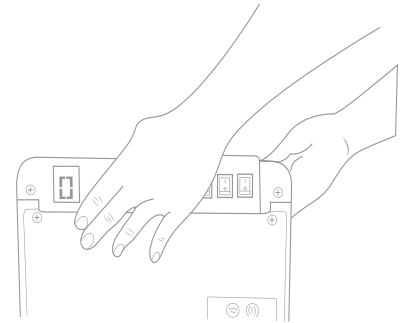
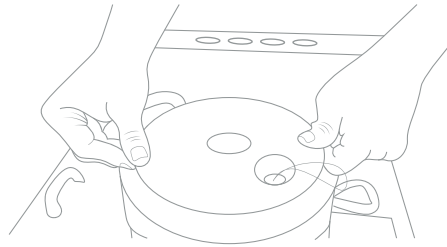
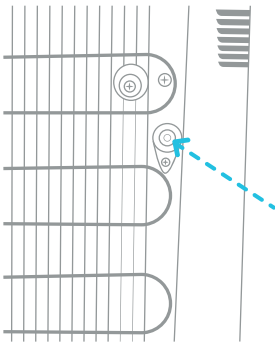

Cleaning

To remove mineral deposits that may have built up inside the the cold tank, mix 4 L of water with 200 g of citric acid crystals (not included) or cleaning solution of your choice.

1. Unscrew the top cover and lift off the cold tank lid.

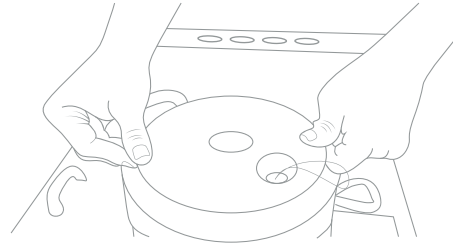
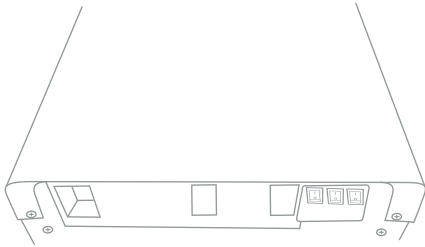

2. Put the mixture into the machine's cold tank and make sure the water can flow out of the spout (#10).

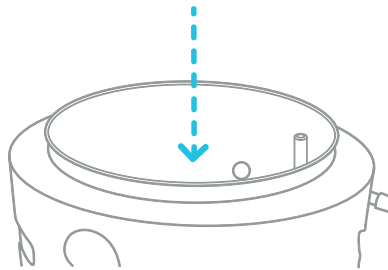

Cleaning

3. Plug in the power cord and turn on (I) the heating switch (#18). Allow the water to heat for 15 minutes.

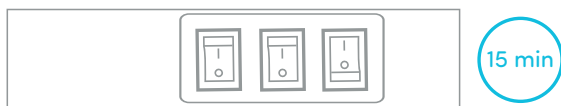

4. Turn off (O) the heating switch (#18) and allow the liquid mixture to cool down for 20 minutes.



5. Drain the liquid from the drain outlet (#20), then flush with water two or three times by following the rinsing instructions above. Only disassemble parts mentioned to avoid damaging the machine.

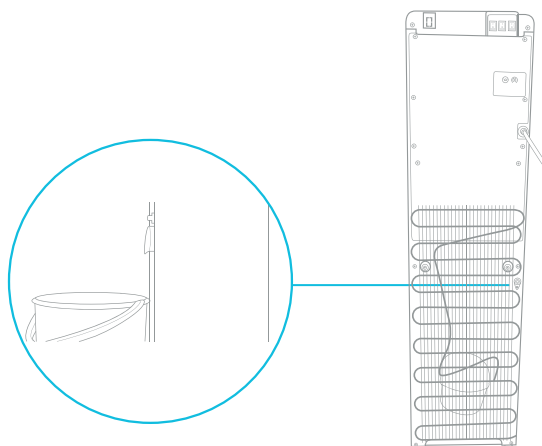

Troubleshooting

Troubleshooting

If you are having trouble with your water cooler please see the following solutions. You can also view our trouble shooting videos at the website below. Please feel free to contact us with any questions.



1-800-256-0695



support@avalonh2o.com



www.avalonh2o.com

Troubleshooting

Indicator lights are flashing and unit is beeping

If indicator lights #1, #2, #3, #4 are flashing and the unit is making a slow beeping sound, it is alerting you that there may be a leak in the unit. Please refer to page 24.

Water leaking from unit

- Check to make sure that pipes are contact properly
- Inspect the adapter to ensure the proper connection
- Water pipe may need to be replace

Water not dispensing at a hot or cold temperature

This could be caused by an over consumption of water in a short period of time causing the tanks to empty. Please allow 5 to 10 minutes for the water cooler tanks to refill. Allow the proper time for the water to heat and cool.

This could be caused by an interruption in the power supply. Please ensure that the power cord is connected to an outlet. Please make sure that the heating (#18) and cooling (#17) switches are in the on (I) position.

Safety

Safety

To reduce risk of injury and property damage, user must read this entire guide before assembling, installing and operating the dispenser.

Failure to execute the instructions in this manual can cause personal injury or property damage.

This product dispenses water at very high temperatures. Failure to use this properly can cause personal injury.

When operating this dispenser, always exercise basic safety precautions, including the following:

- Prior to use, this dispenser must be properly assembled and installed in accordance with this manual.
- This dispenser is intended for water dispensing only. Do NOT use other liquids. Do NOT use for other purposes. Never use any other liquid in the dispenser other than known microbiologically safe tap water.
- For indoor use only. Keep water dispenser in a dry place away from direct sunlight. Do NOT use outdoors.
- Install and use only on a hard, flat and level surface.
- Do NOT place dispenser in an enclosed space or cabinet.
- Do NOT operate the dispenser in the presence of explosive fumes.
- Position back of dispenser no closer than 20 cm from wall and permit free airflow between wall and dispenser. There must be at least 20 cm clearance on the sides of the dispenser to permit airflow.
- Use only properly grounded outlets.
- Do not use an extension cord with your water dispenser.
- Always grasp plug and pull straight out from outlet. Never unplug by pulling on power cord.
- To protect against electric shock, do NOT immerse cord, plug or any other part of the dispenser in water or other liquid.

Safety

- Ensure dispenser is unplugged prior to cleaning.
- Never allow children to dispense hot water without proper and direct supervision. Unplug unit to prevent unsupervised use by children.
- Service should be performed only by a certified technician.
- Warning: Do not damage the refrigerant circuit.
- This appliance can be used by children aged from 8 years and above if they have been given supervision or instruction concerning use of the appliance in a safe way and if they understand the hazards involved. Cleaning and user maintenance shall not be made by children unless they are older than 8 and supervised. Keep the appliance and its cord out of reach of children less than 8 years.
- Appliances can be used by persons with reduced physical, sensory or mental capabilities or lack of experience and knowledge if they have been given supervision or instruction concerning use of the appliance in a safe way and understand the hazards involved. Children shall not play with the appliance.
- This appliance is intended to be used in a household and similar applications such as: kitchen area in shops, offices and other working environments, bed and breakfast type environments, catering and similar non-retail applications.
- Do not store explosive substances such as aerosol cans with flammable propellant in this appliance.
- If the supply cord is damaged, it must be replaced by a special cord assembly available from the manufacturer or its service agent.
- Never turn the machine upside down or lean it more than 45°.
- Thermostat has been adjusted. There is no need to adjust it by yourself. When the matching is below the freezing point and blocked by ice, the cooling switch should be turned off for 4 hours before turning it on again to continue its operation.
- This machine should not be plugged back in until 3 minutes after it has been unplugged.

