

Tri Fold Cabinet Bed, Queen

Date of Purchase ___ / ___ / ___

Lot Number:

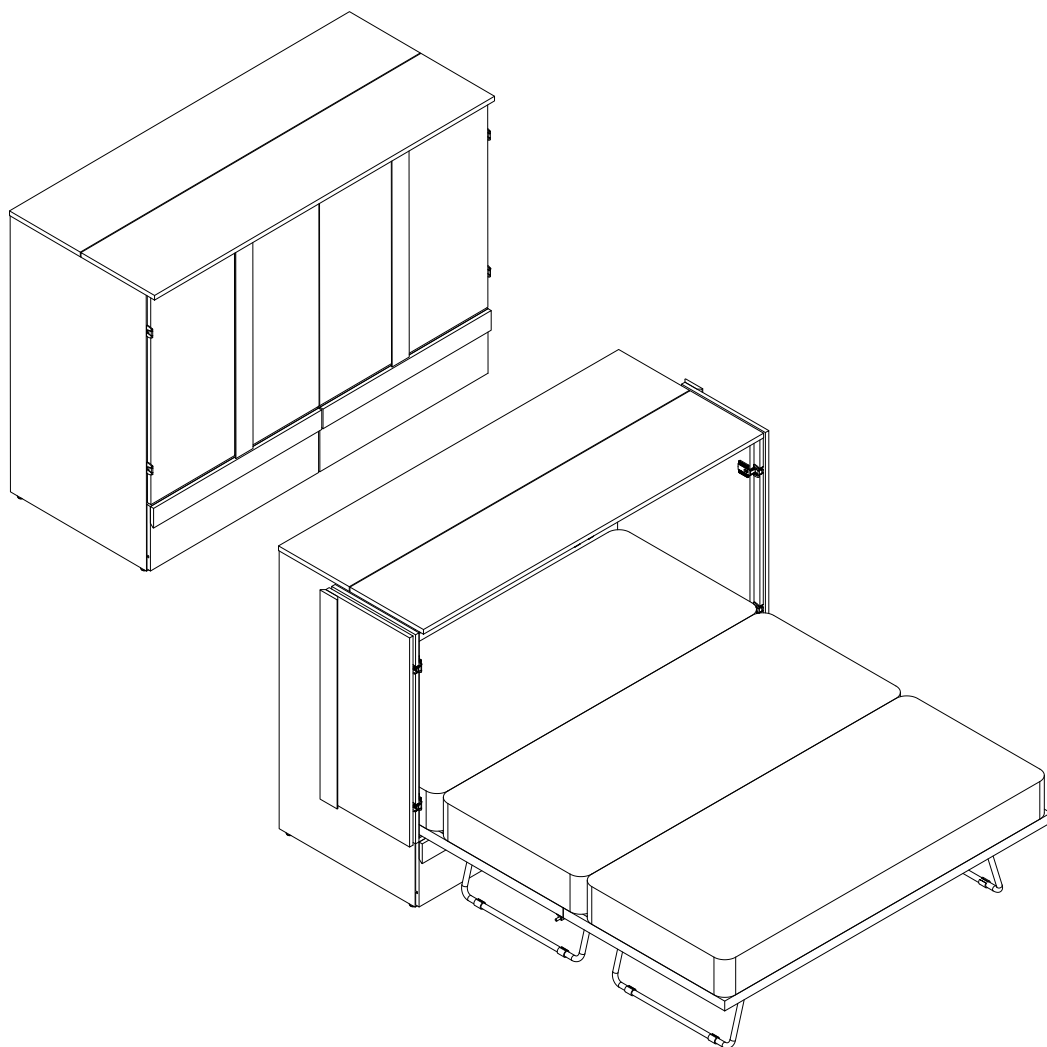

THIS INSTRUCTION BOOKLET CONTAINS **IMPORTANT** SAFETY INFORMATION. PLEASE READ AND KEEP FOR FUTURE REFERENCE.

Secure Your Furniture

Keep your home and family safe with the wall anchor kit that is included with the product.

Serious or fatal crushing injuries can occur from tipping furniture.

WARNING: Manufacturer assumes no liability for improper installation or excessive loads placed on screws or bracket. This wall anchor is not a substitute for proper adult supervision.

Helpful Hints

PEOPLE NEEDED FOR ASSEMBLY: 2

- Open your item in the area you plan to keep it to avoid excessive heavy lifting.
- Identify, sort and count the parts before attempting assembly.
- Compression dowels are lightly tapped in with a hammer.
- Do NOT use harsh chemicals or abrasive cleaners on this item.
- Never push, pull, or drag your furniture.

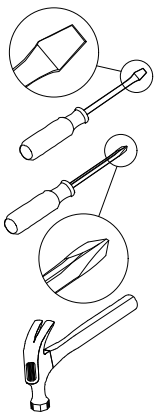
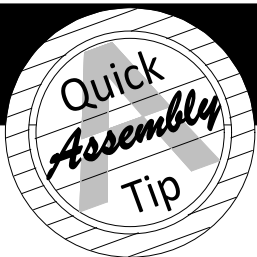

Before You Start

- ✓ Read through each step carefully and follow the proper order
- ✓ Separate and count all your parts and hardware
Parts are labeled on the surface or edge of the part
- ✓ Give yourself enough room for the assembly process
- ✓ Have the following tools: Flat Head Screwdriver, #2 Phillips Head Screwdriver and Hammer
- ✓ Caution: If using a power drill or power screwdriver for screwing, please be aware to slow down and stop when screw is tight. Failure to do so may result in stripping the screw.

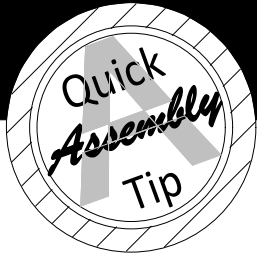

Before You Start

Please Note:

You may need to lightly tap the wood dowels into the holes during your assembly process.

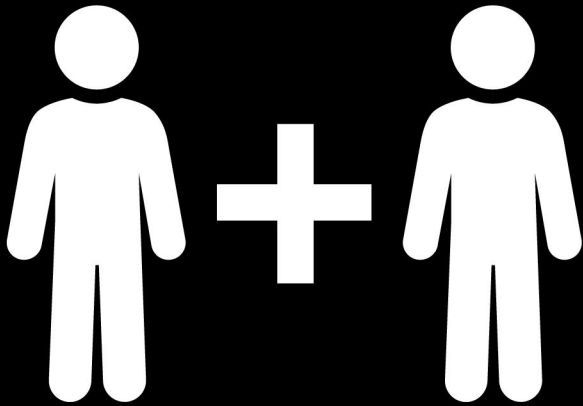
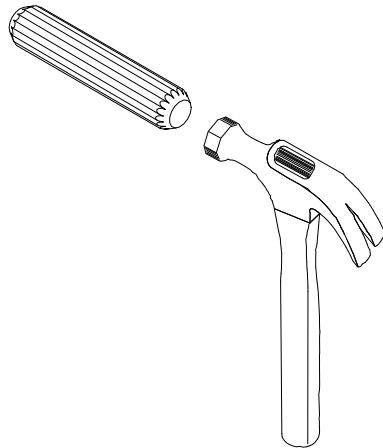

2 PEOPLE NEEDED FOR ASSEMBLY

**2 PERSONAS NECESITADAS
PARA LA ASAMBLEA**

**2 PERSONNES NÉCESSAIRES
POUR L'ASSEMBLAGE**

CAUTION: Failure to use 2 people for assembly could result in unit damage or personal injury.

PRECAUCIÓN: Si no se utilizan 2 personas para el ensamblaje, se pueden producir daños en la unidad o lesiones personales.

ATTENTION: Échec d'utiliser 2 personnes pour l'assemblage peut causer du dommage au meuble ou causer des blessures.

Board Identification

Not actual size

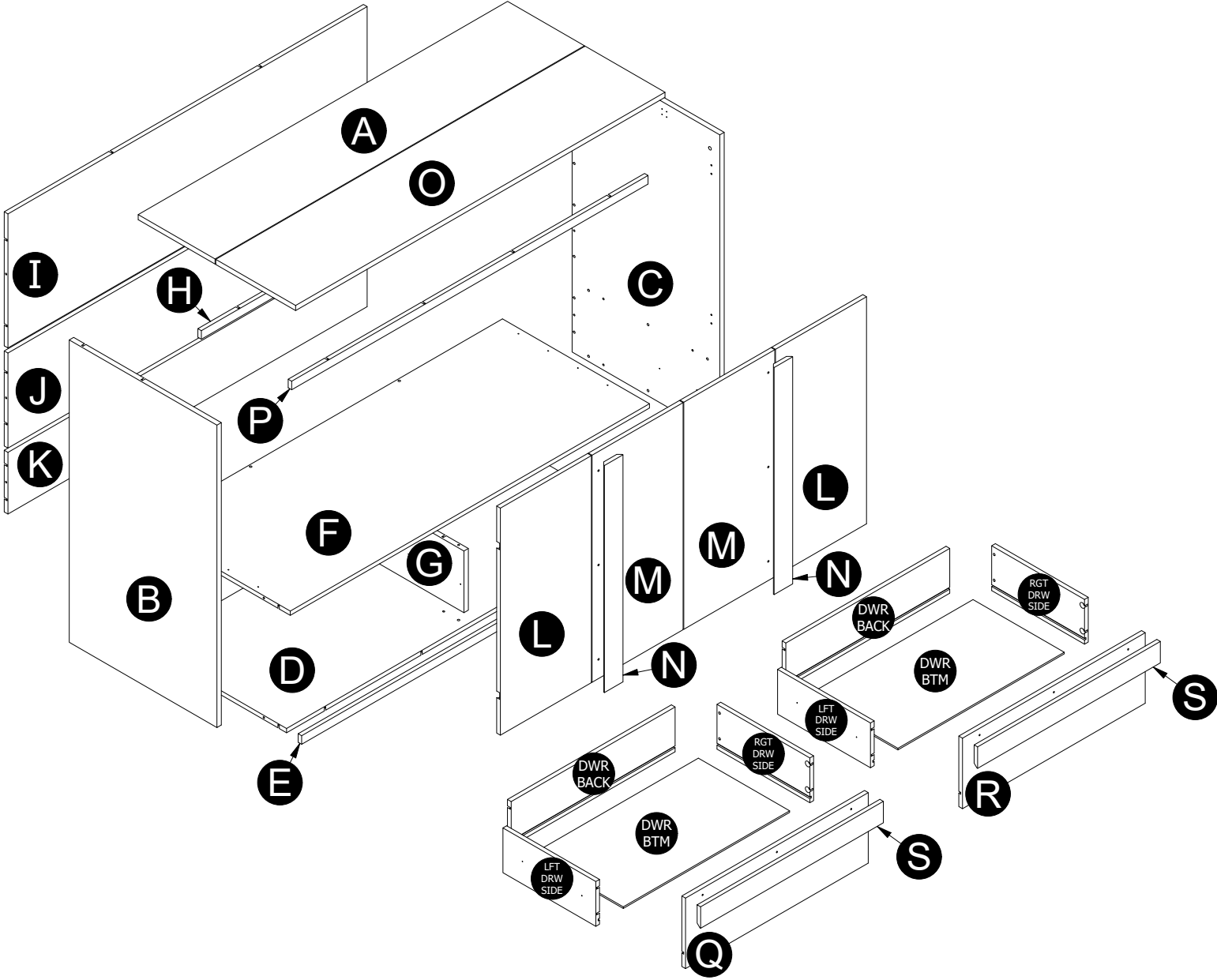

Board Identification

Not actual size

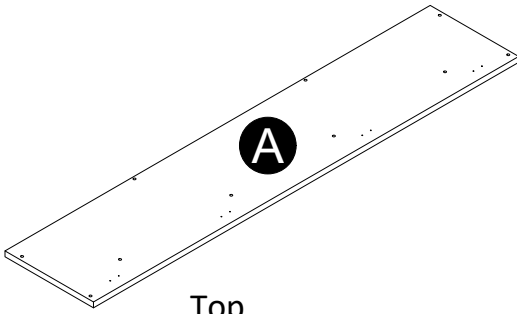

Top
39156341010

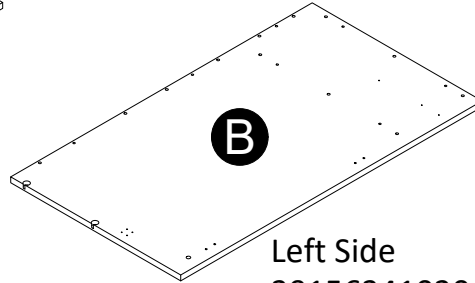

Left Side
39156341020

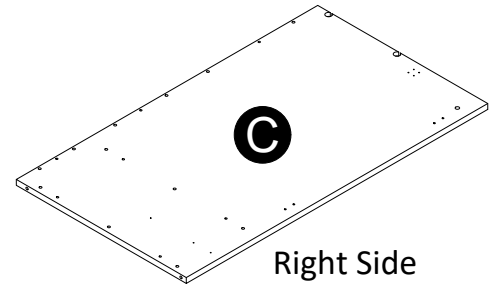

Right Side
39156341030

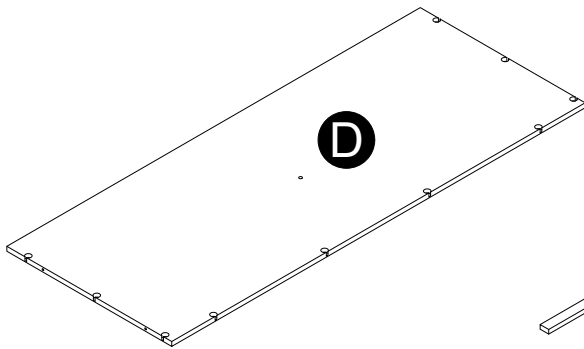

Bottom
39156341040

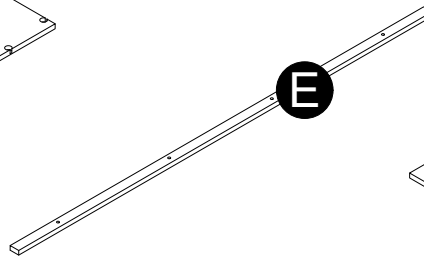

Bottom Rail
39156341050

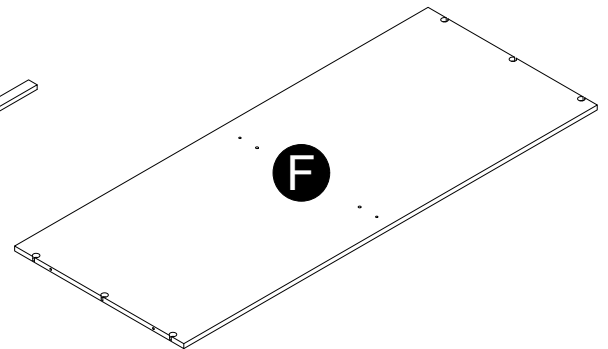

Middle Shelf
39156341060



Partition
39156341070

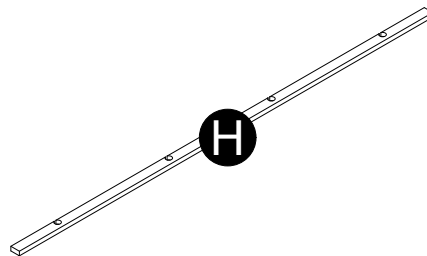

Upper Rear Rail
39156341080

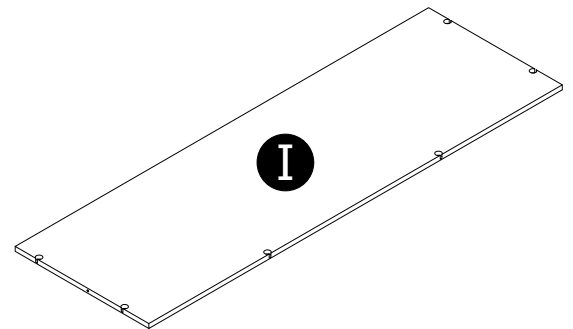

Upper Back
39156341090

Board Identification

Not actual size

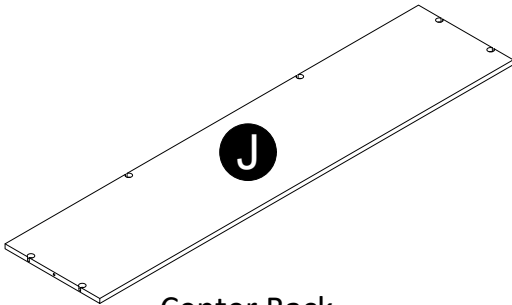

Center Back
39156341100

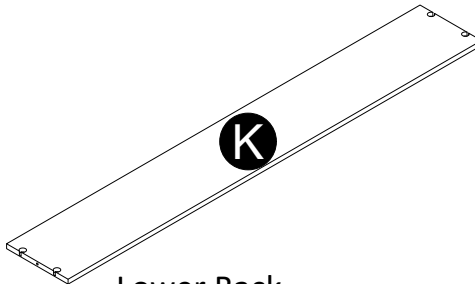

Lower Back
39156000110

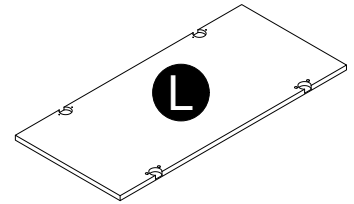

Door Outer
39156341120

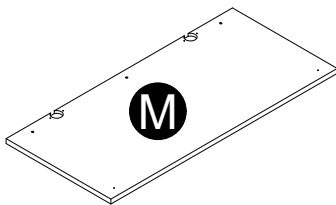

Door Inner
39156341130

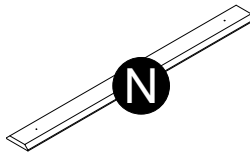

Door Molding
39156341140

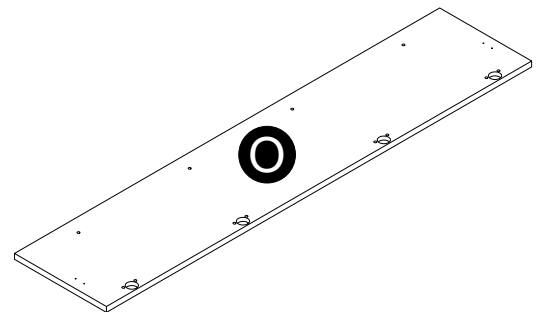

Flip Top
39156341150

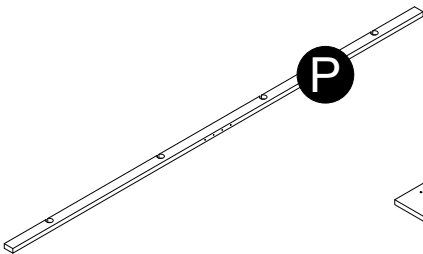

Lift Top Rail
39156341160

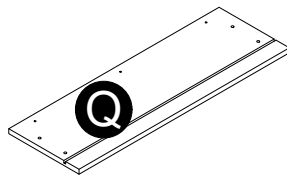

Left Drawer Front
39156341170

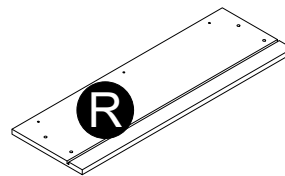

Right Drawer Front
39156341180

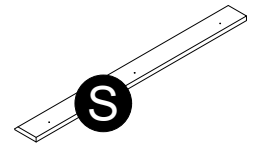

Drawer Molding
39156341190

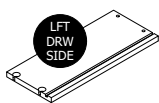

Left Drawer Side
39991167400780L

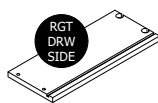

Right Drawer Side
39991167400780R

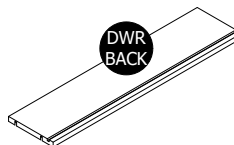

Drawer Back
399911677075730B

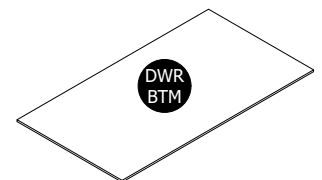

Drawer Bottom
3999139307182D

Part List

Actual Size

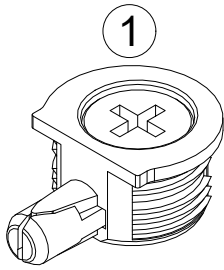

(x64)
#A22830
connector

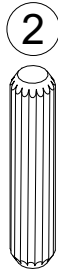

(x18)
#A21670
dowel

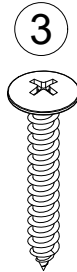

(x12)
#A12940
#8x1-1/8 pan

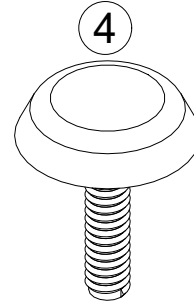

(x4)
#A43020
adjustable glide

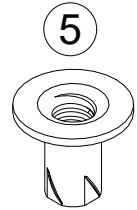

(x4)
#A20330
nut insert

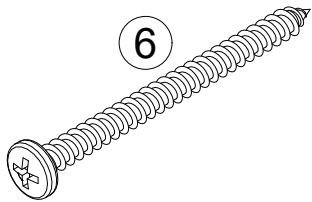

(x8)
#A13715
screw #8x2 pan



(x32)
#12120
#8x7/16 truss



(x16)
#A12400
#8x5/8 flat

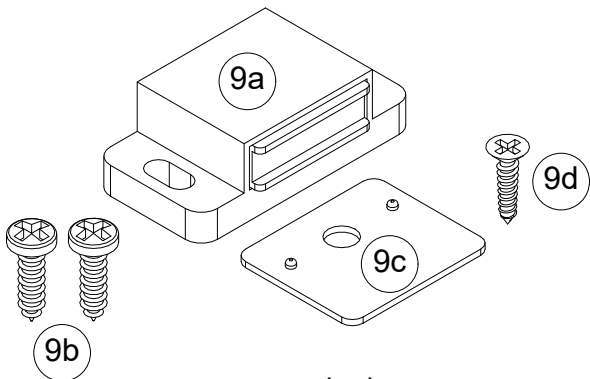

(x2)
#A31000
Magnet Kit

Part List

Not Actual Size

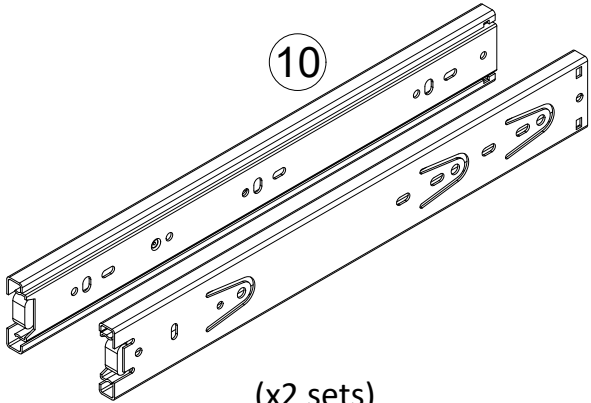

(x2 sets)
#A56100
slide

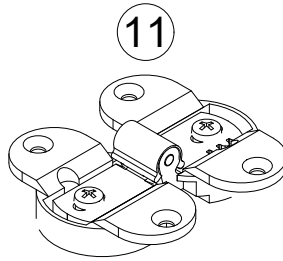

(x4)
#A60530
hinge

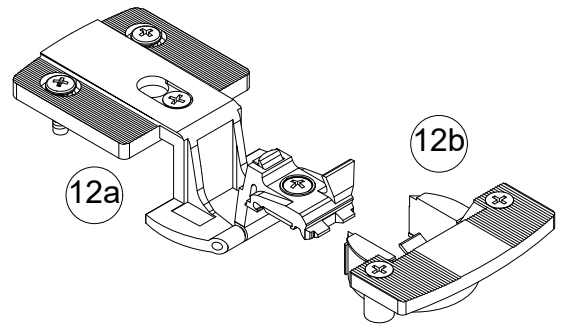

(x4)
#A60540/A60545
hinge

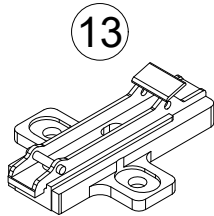

(x4)
#A60550
hinge plate

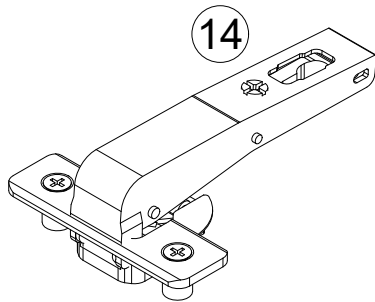

(x4)
#A60555
hinge

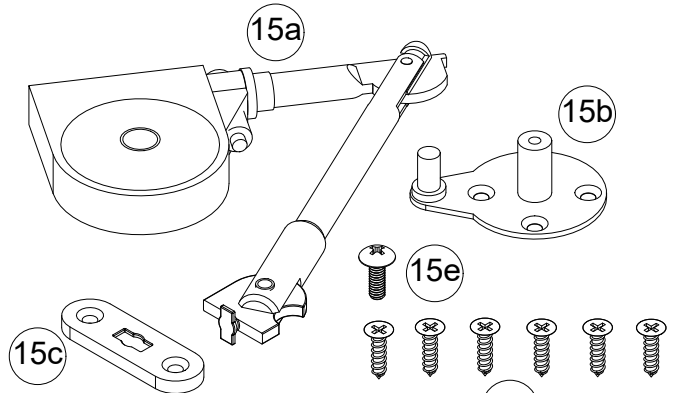

(x2)
#A67750
lid stay kit

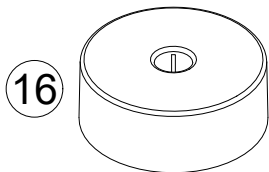

(x1)
#A43490
spacer

Part List

8491096COM Bed Frame assembly carton contents

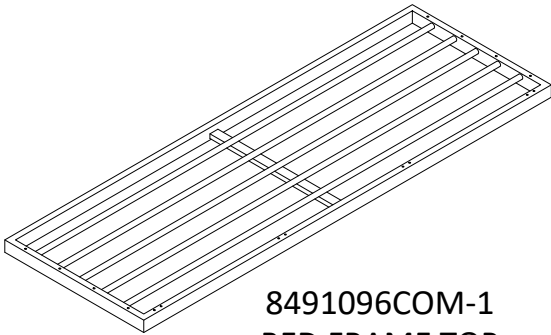

8491096COM-1
BED FRAME TOP

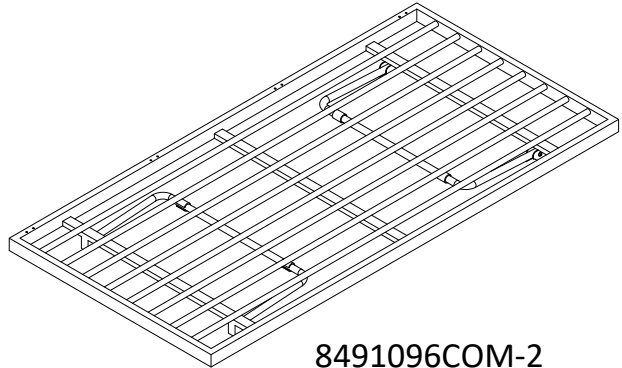

8491096COM-2
BED FRAME BOTTOM

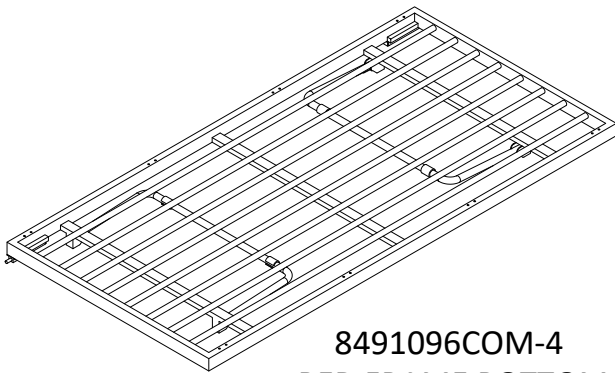

8491096COM-4
BED FRAME BOTTOM
(includes latches)

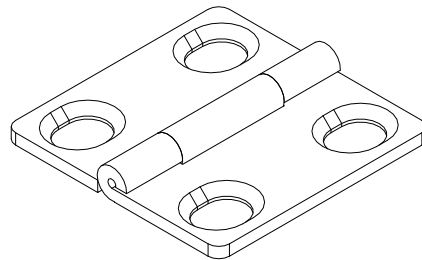

8491096COM-3
hinge
(x8)

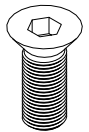

8491096COM-9
screw
(x32)

6411449 Mattress

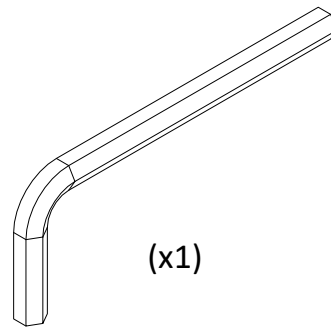
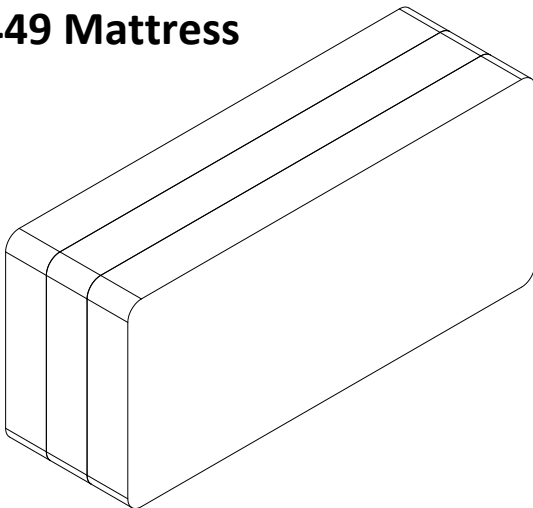

(x1)

Part List

Not Actual Size

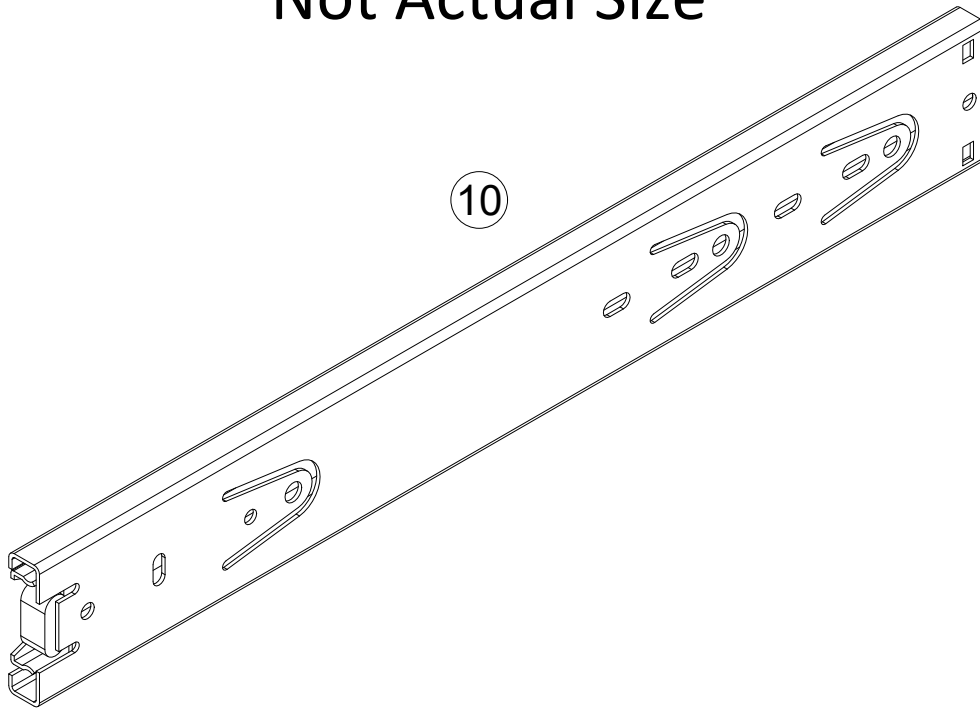

Your unit comes with assembled drawer slides. For each slide, extend the slide as shown and press the release to remove the inner slide. Set the inner slide aside for later. For Step 1, 2, and 7 you will be attaching the outer slide to the panels. While sliding the middle slide, locate the holes in the panels with the access holes in the middle slide and fasten with screws.

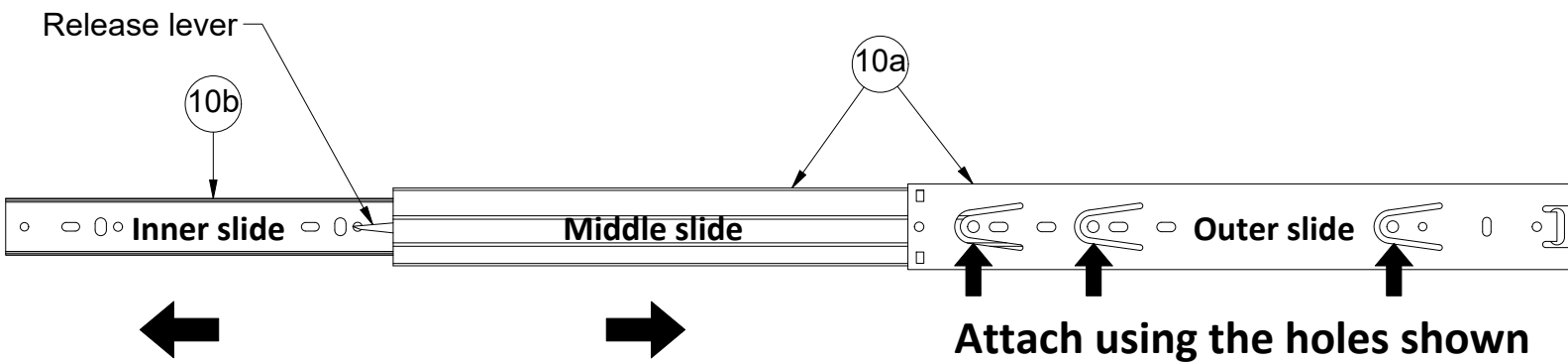

STEP 1

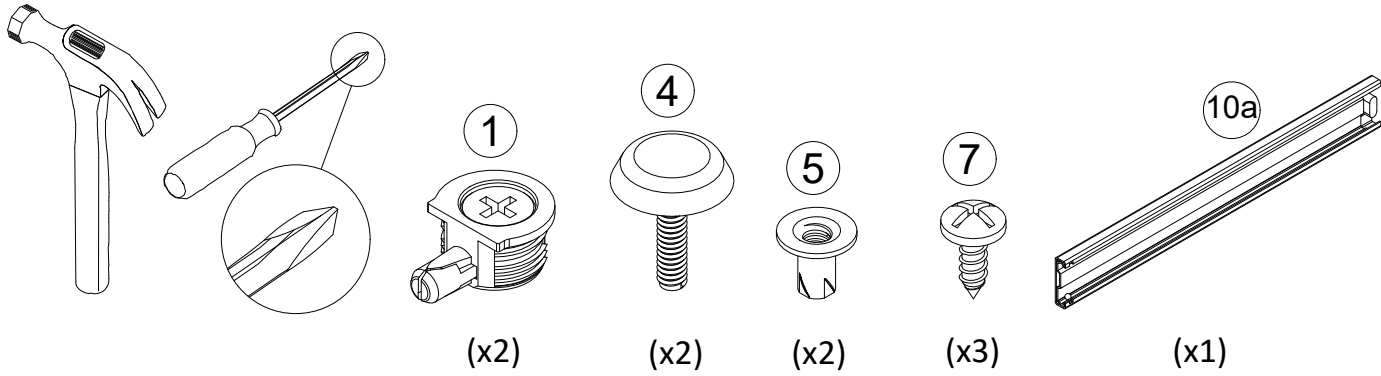

Refer to page 11 for slide installation instructions.

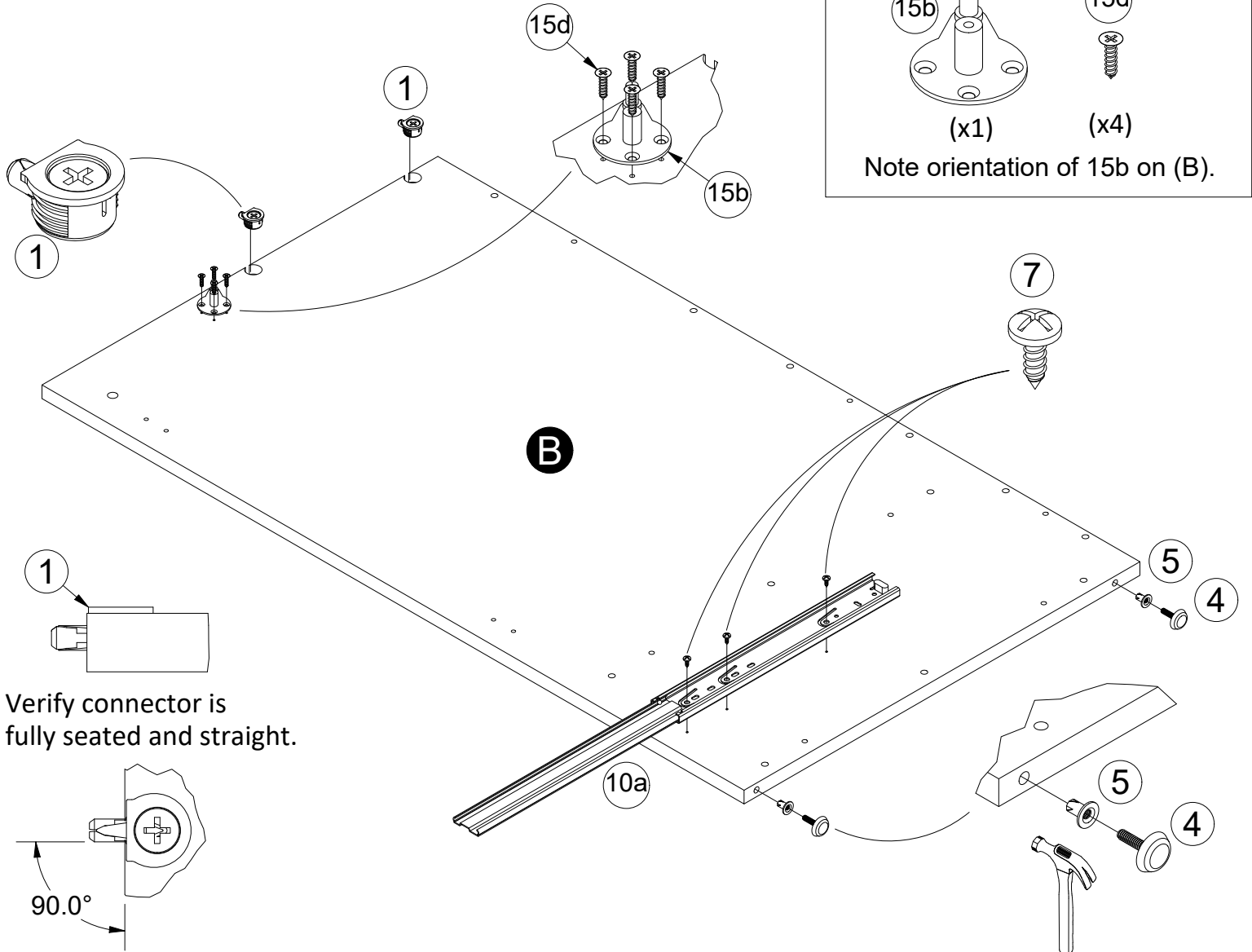

STEP 2

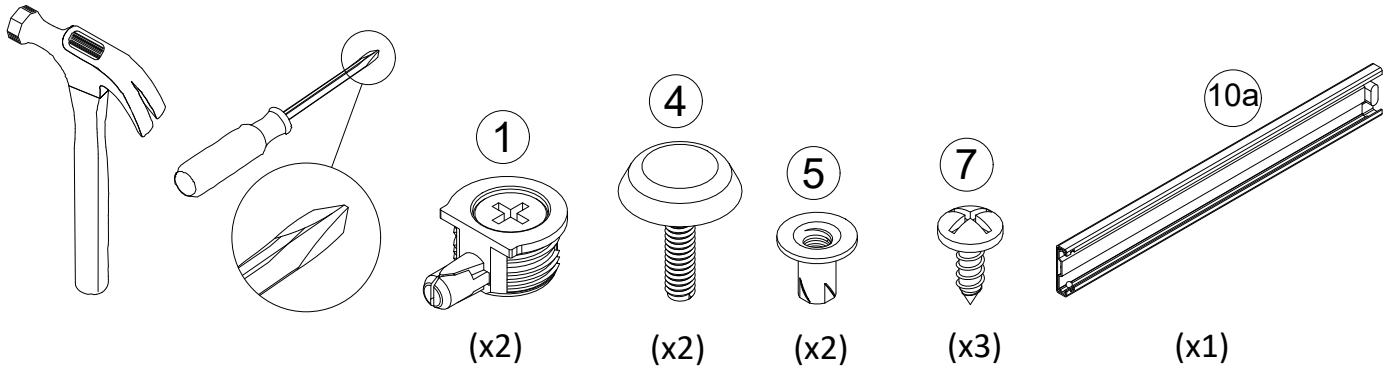

Refer to page 11 for slide installation instructions.

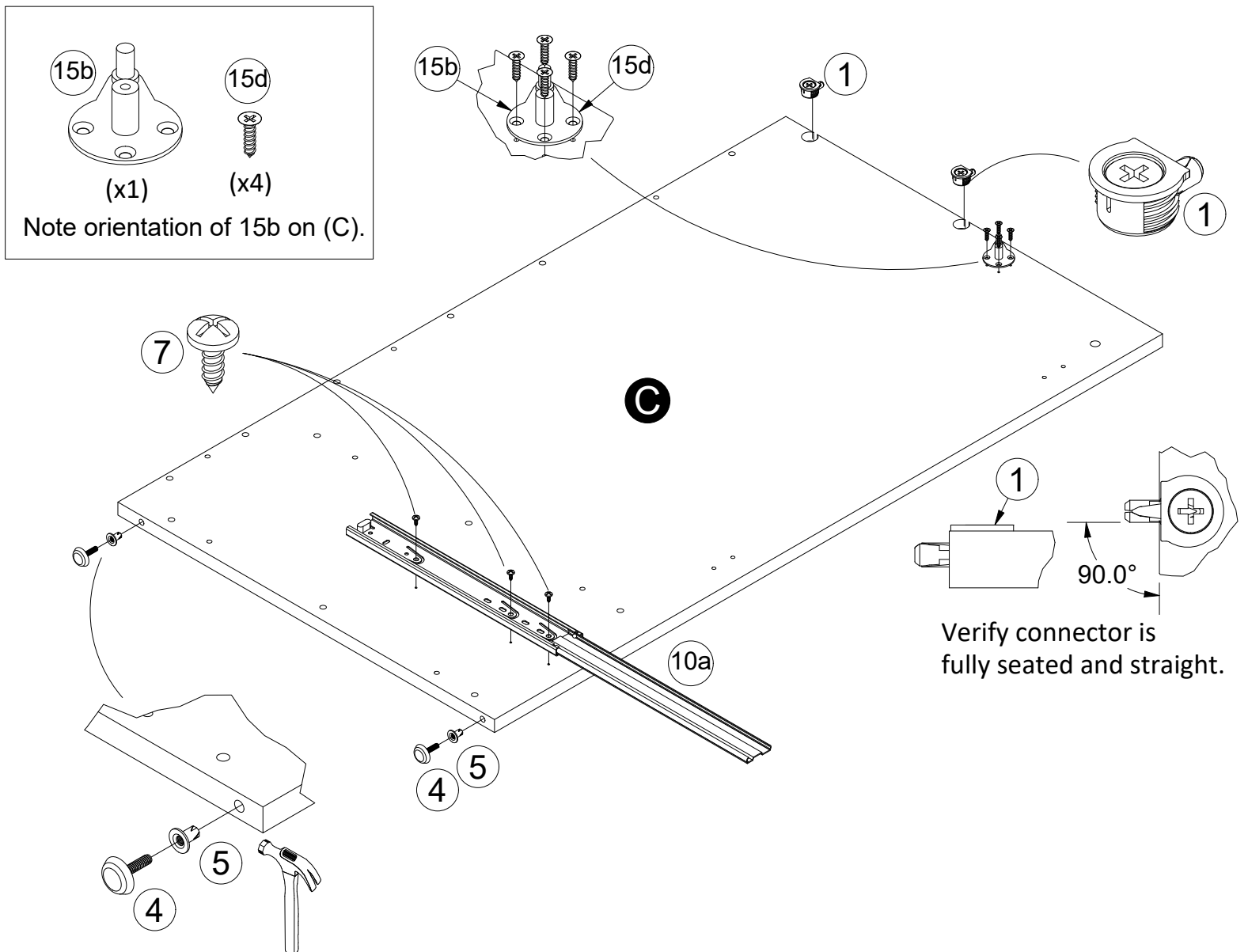

STEP 3

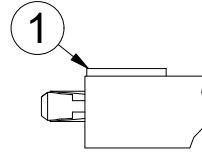
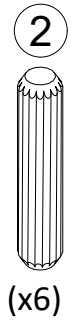
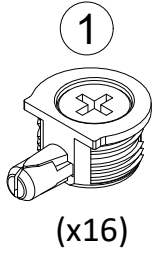
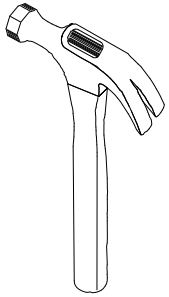

Verify connector is fully seated and straight.

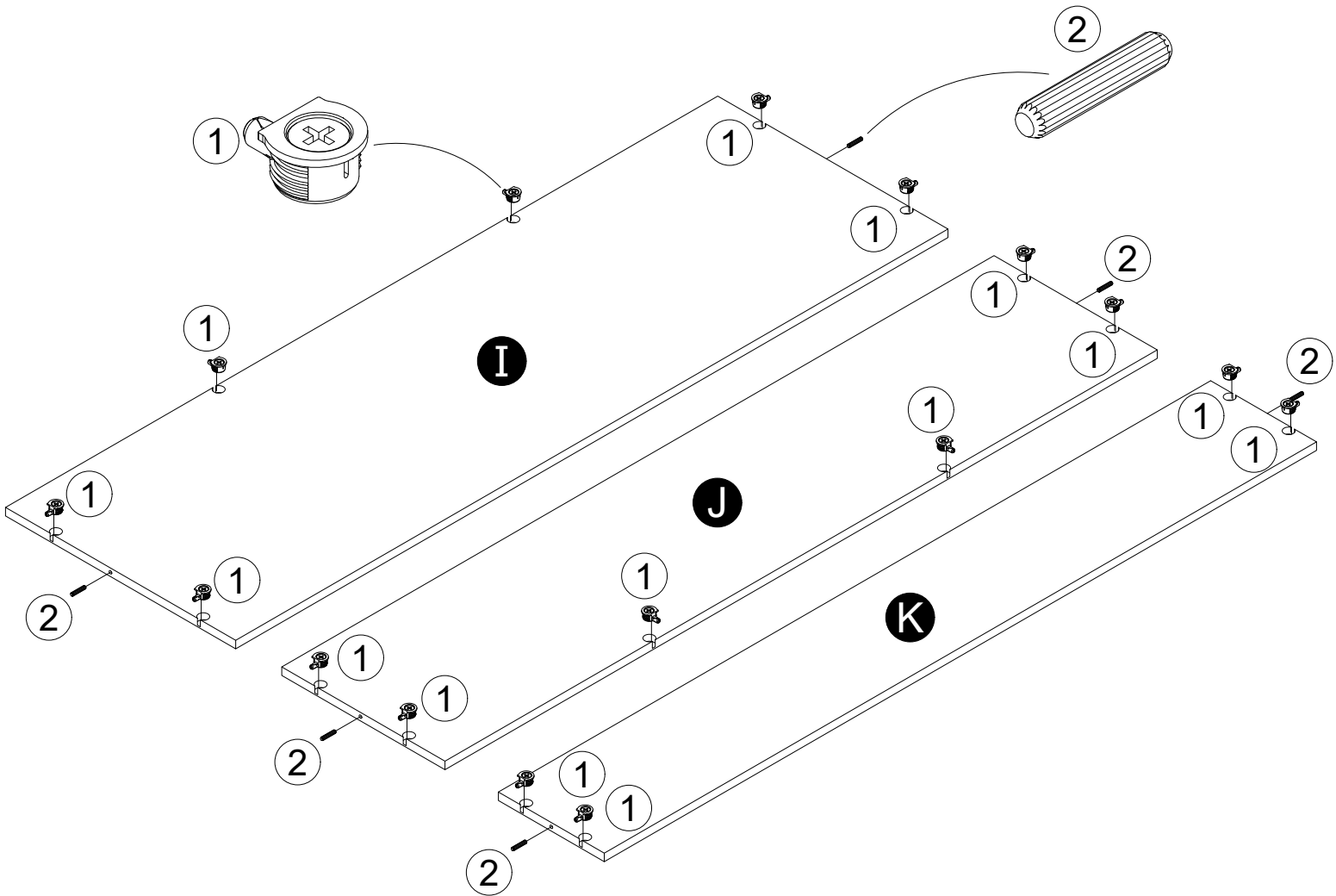
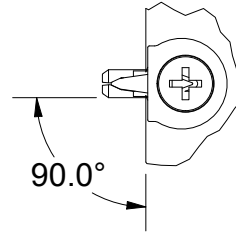

STEP 4

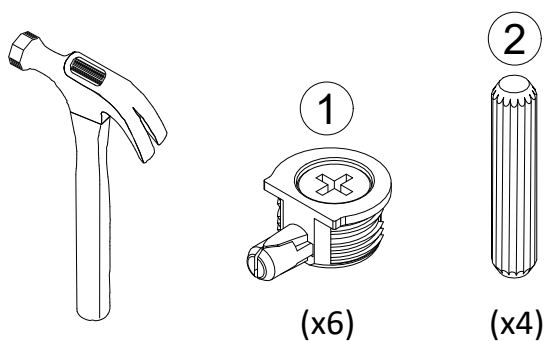

Verify connector is fully seated and straight.

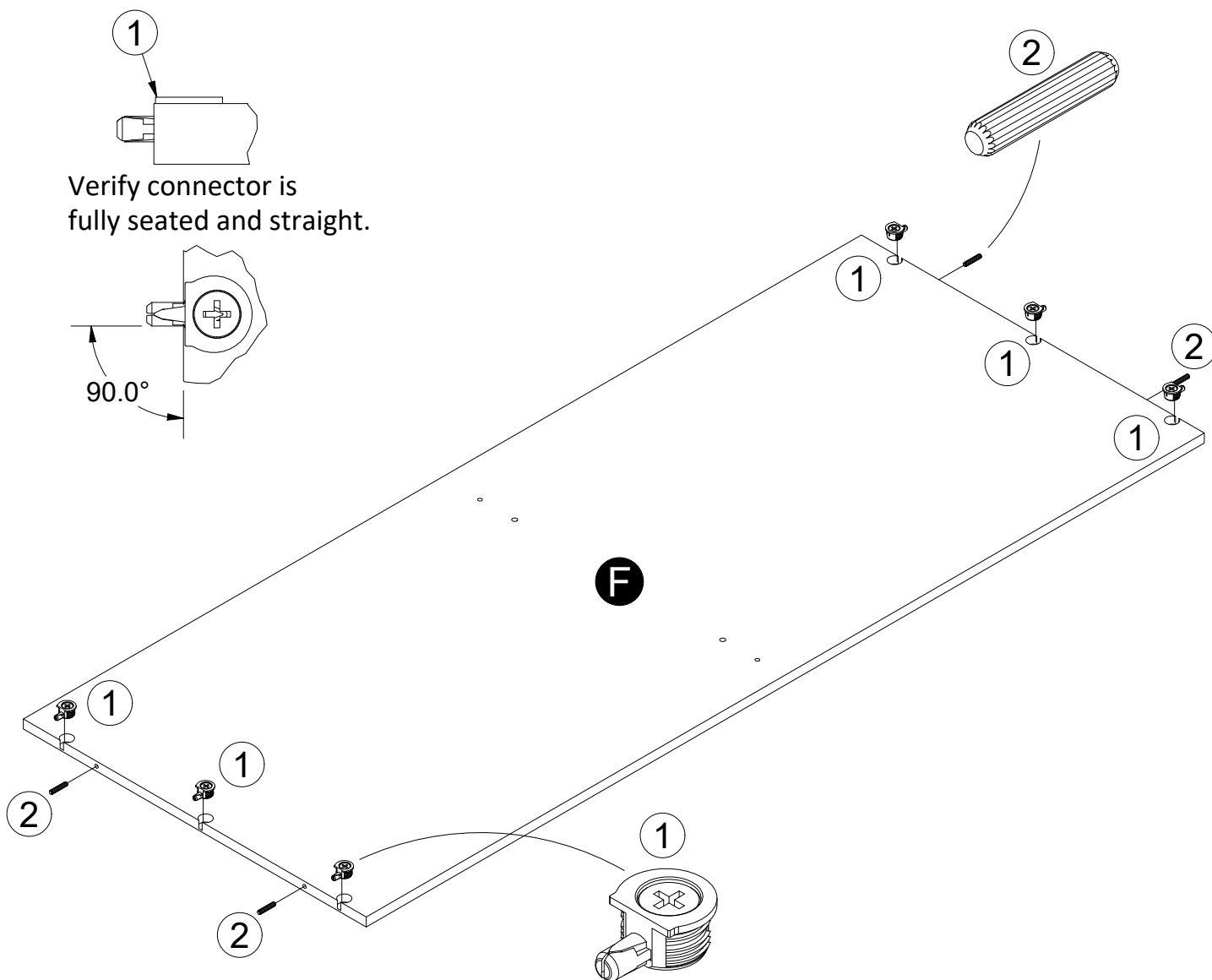
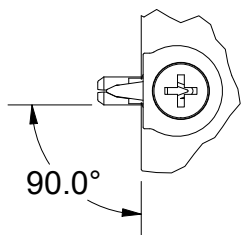

STEP 5

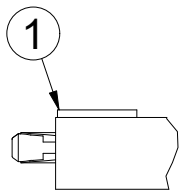
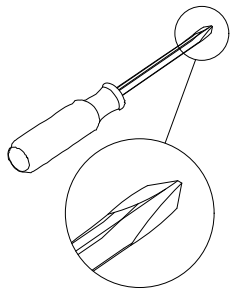

Verify connector is fully seated and straight.

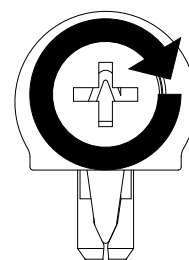
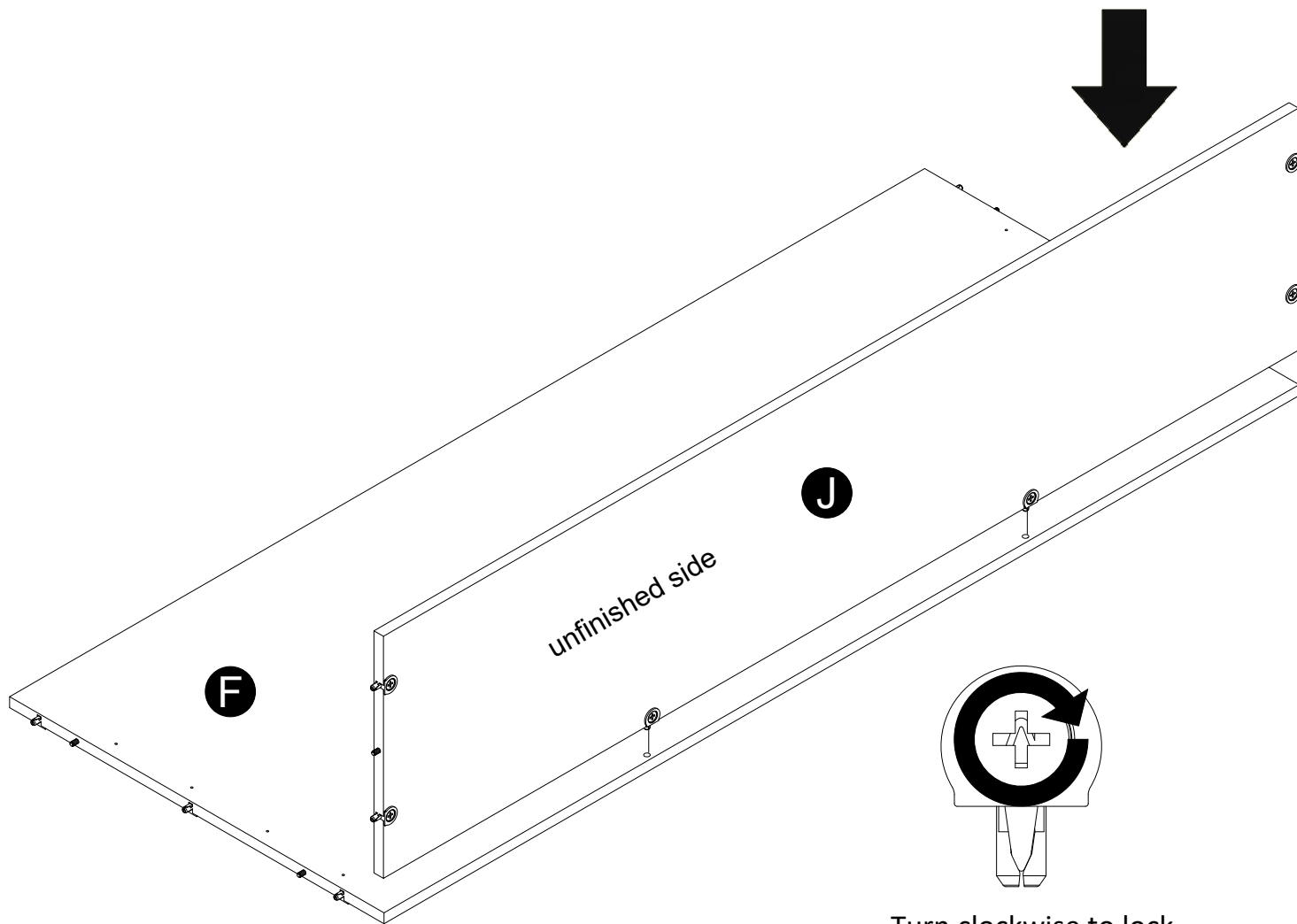
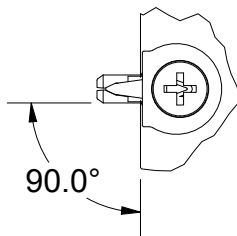

Turn clockwise to lock into place

STEP 6

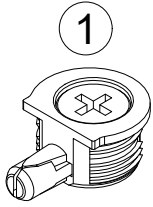
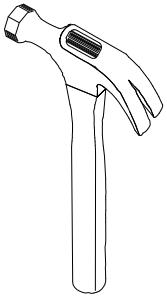

(x10)

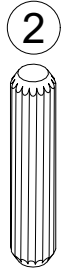

(x4)

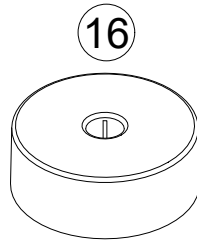

(x1)

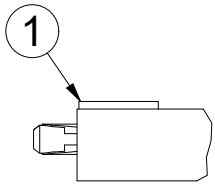

Verify connector is fully seated and straight.

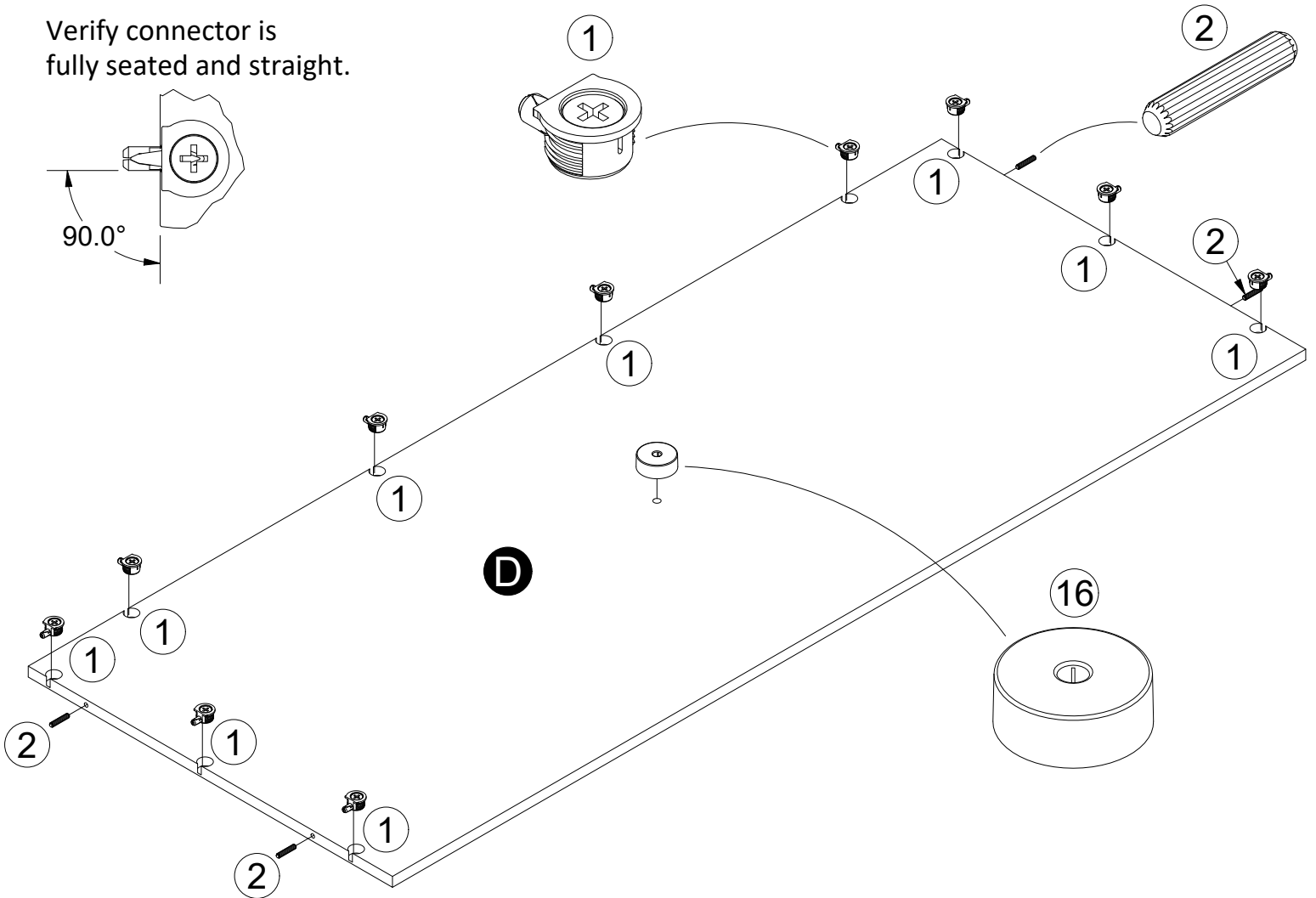
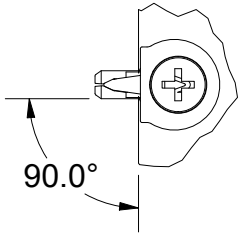

STEP 7

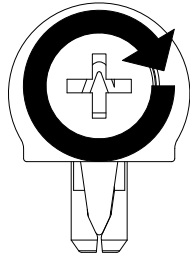
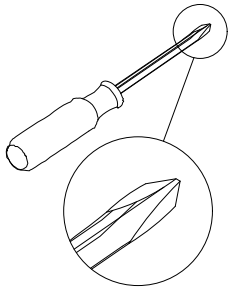

Turn clockwise to lock into place

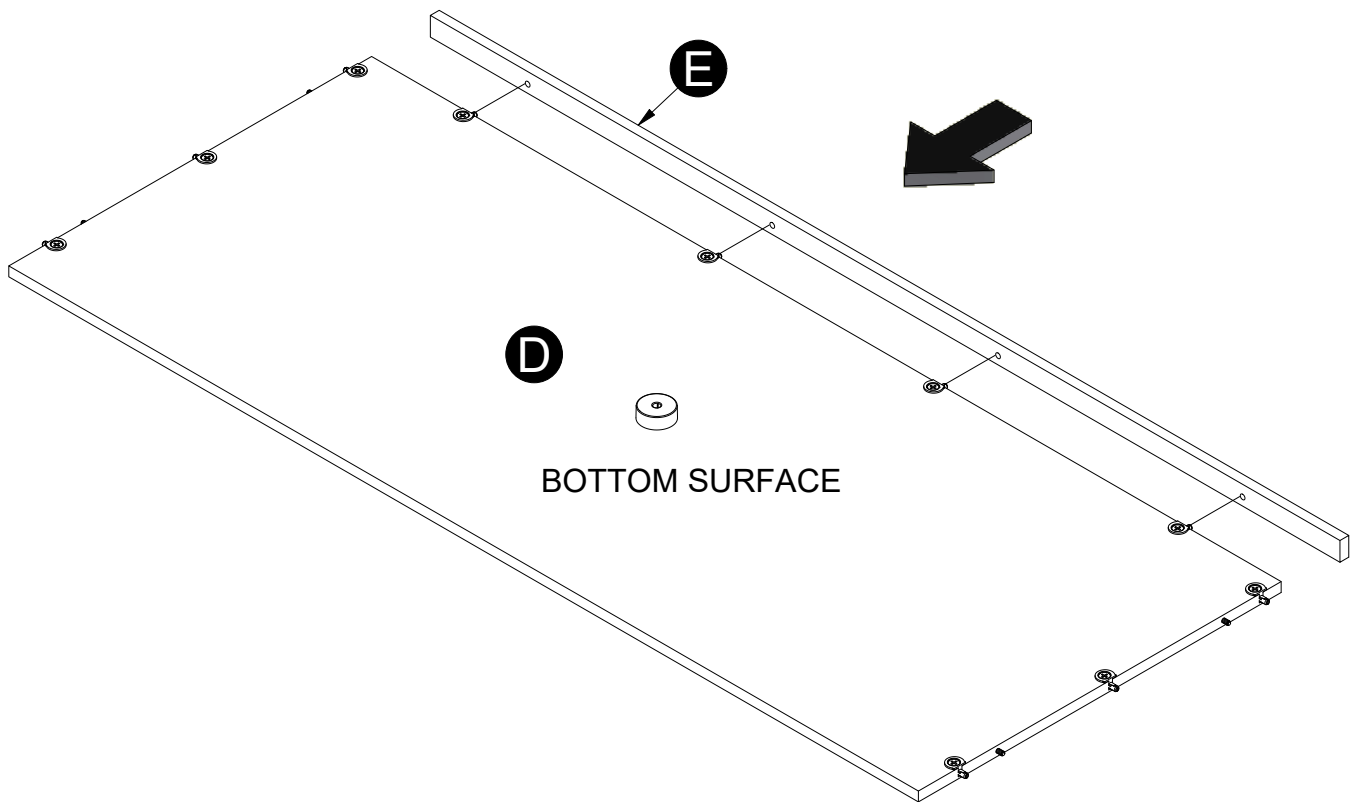
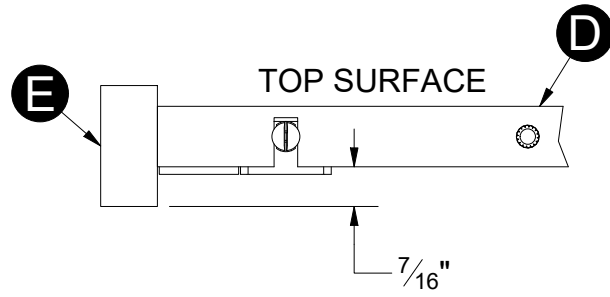

STEP 8

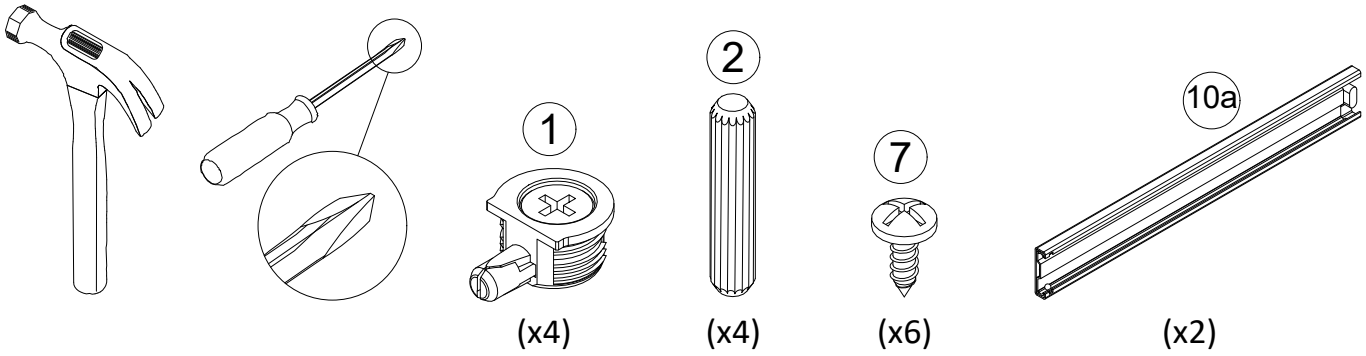

Refer to page 11 for slide installation instructions.

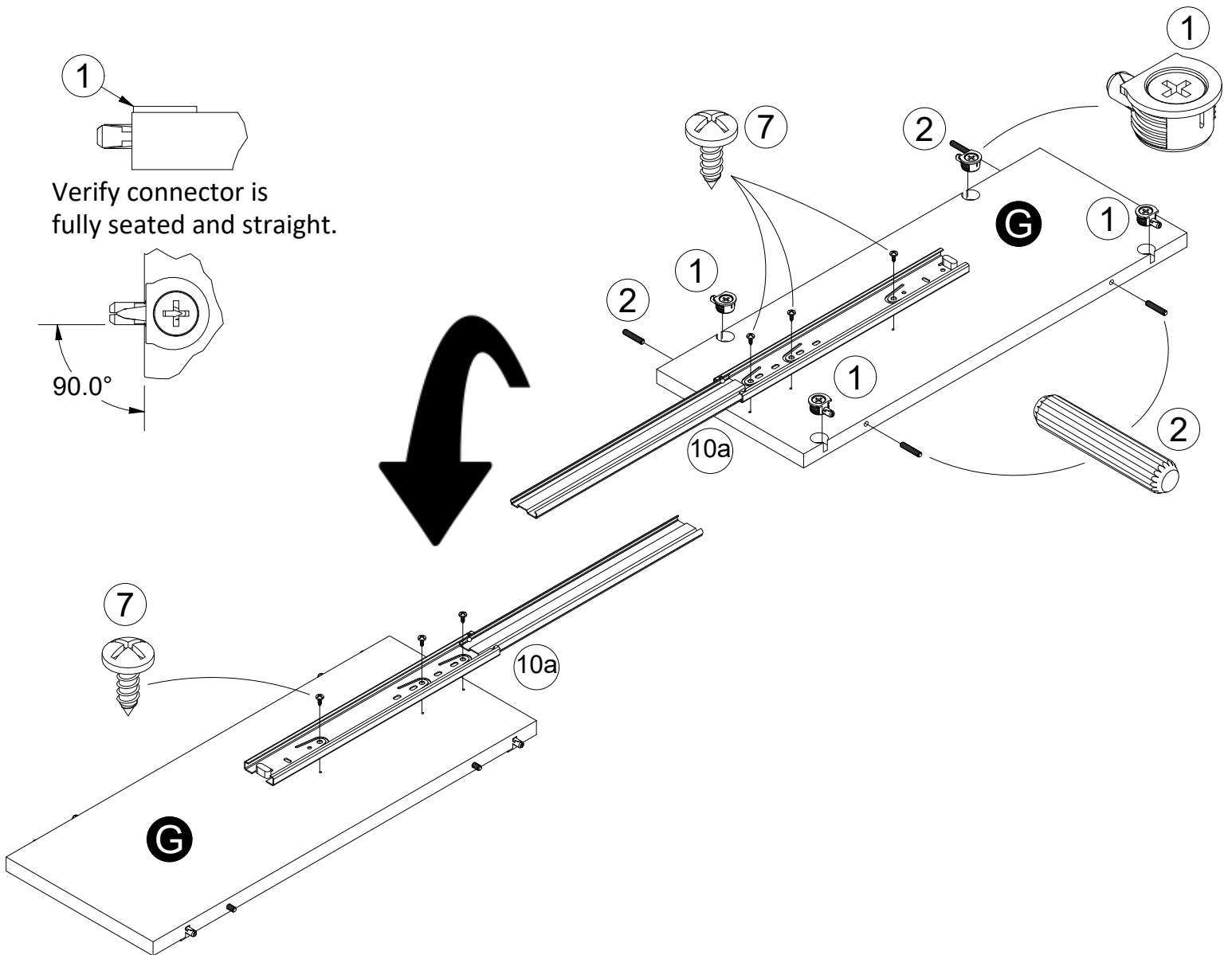

STEP 9

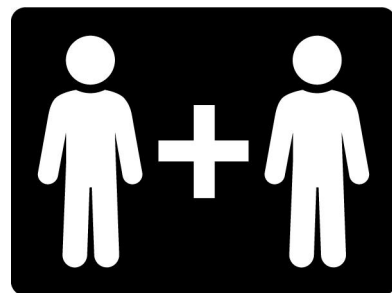
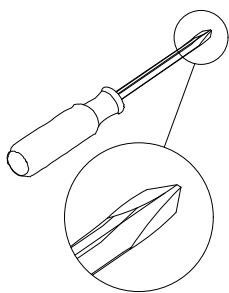

Fasten 1st

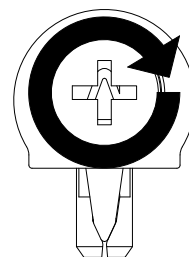
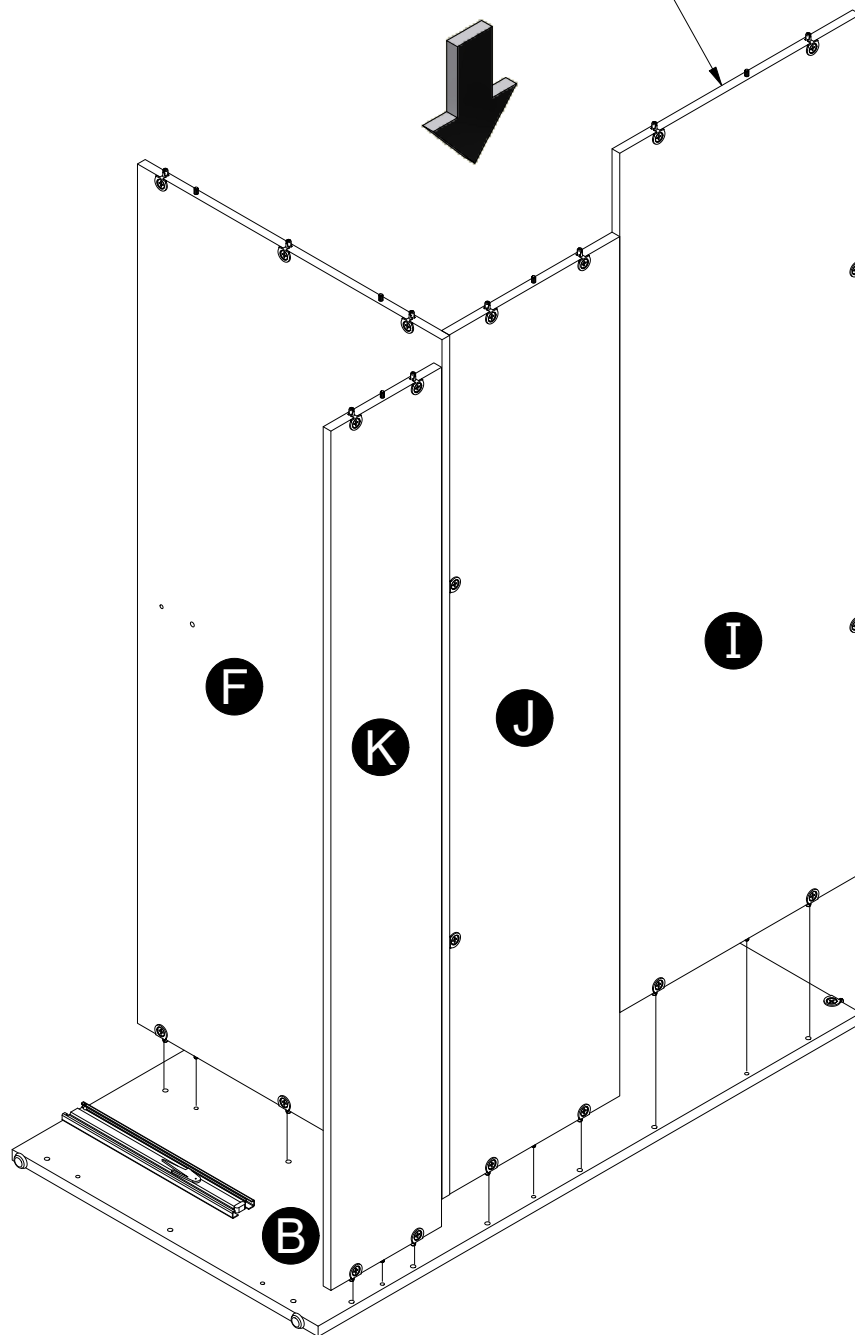

Turn clockwise to lock into place

STEP 10

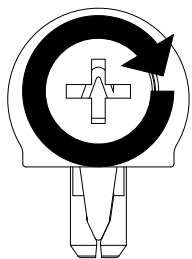
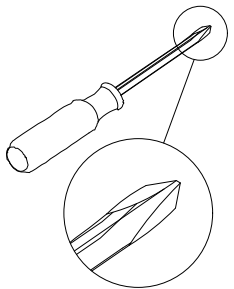

Turn clockwise to lock
into place

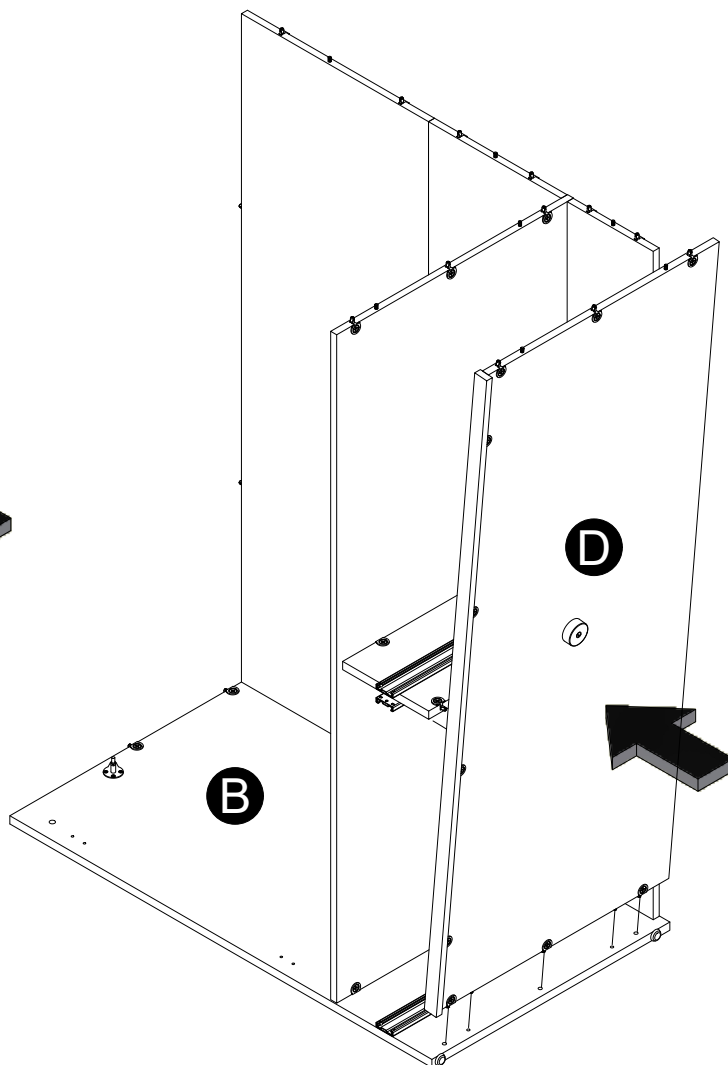
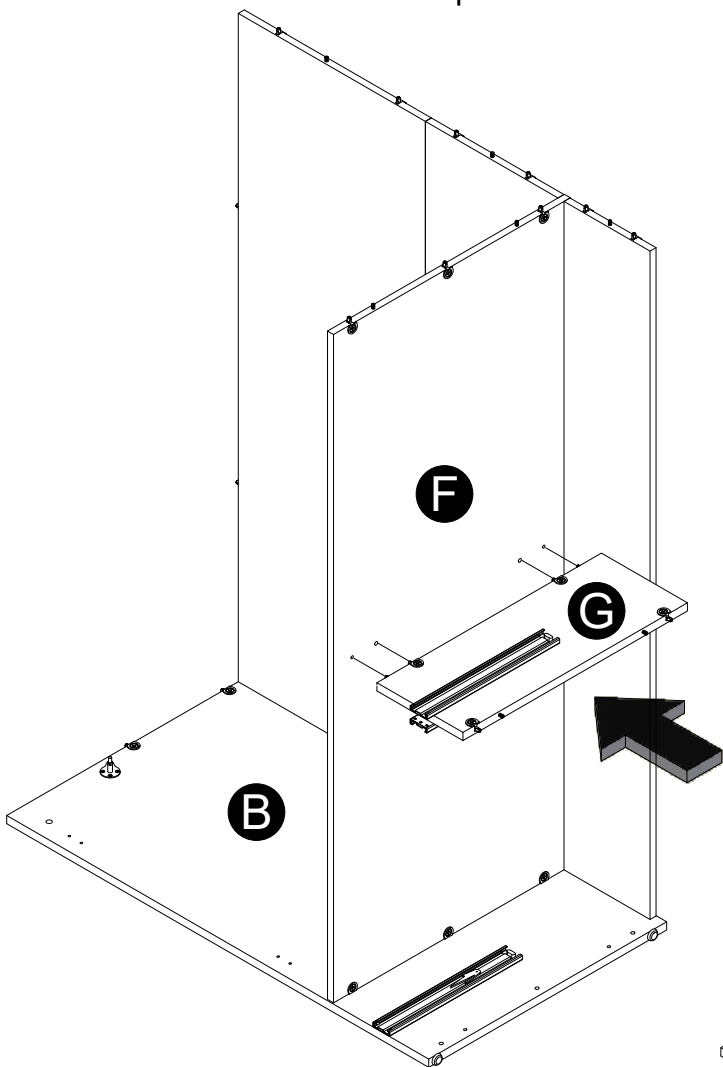
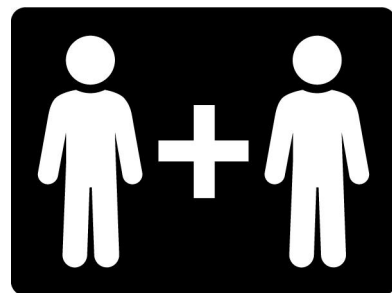

STEP 11

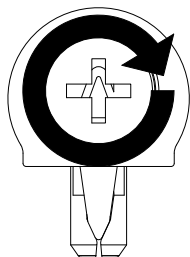
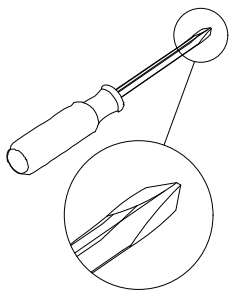

Turn clockwise to lock into place

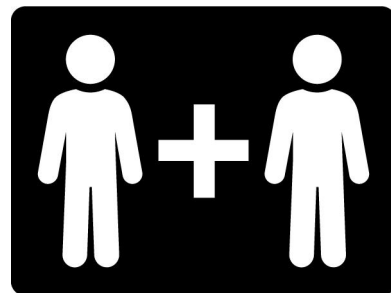
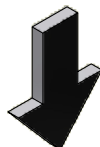

finished edge

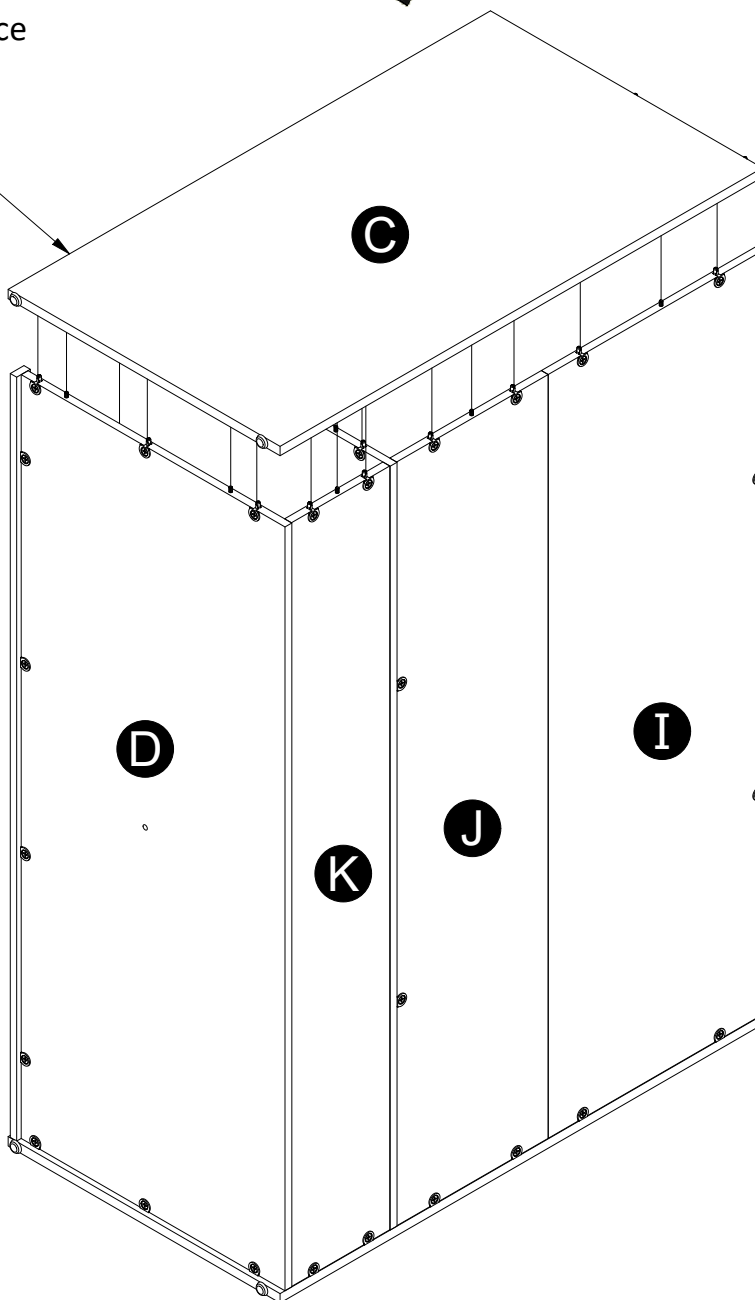

STEP 12

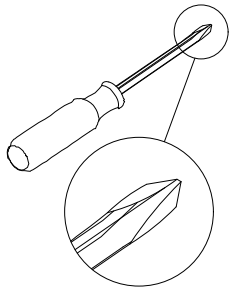

Turn clockwise to lock into place

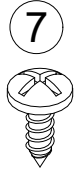

(x8)

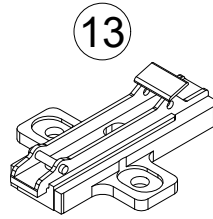

(x4)

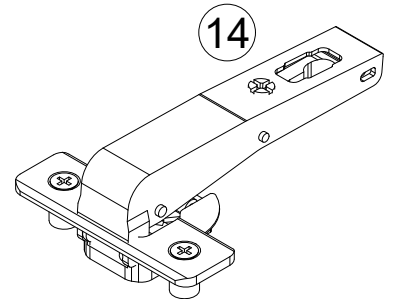

(x4)

Assemble hinge by snapping together as shown.

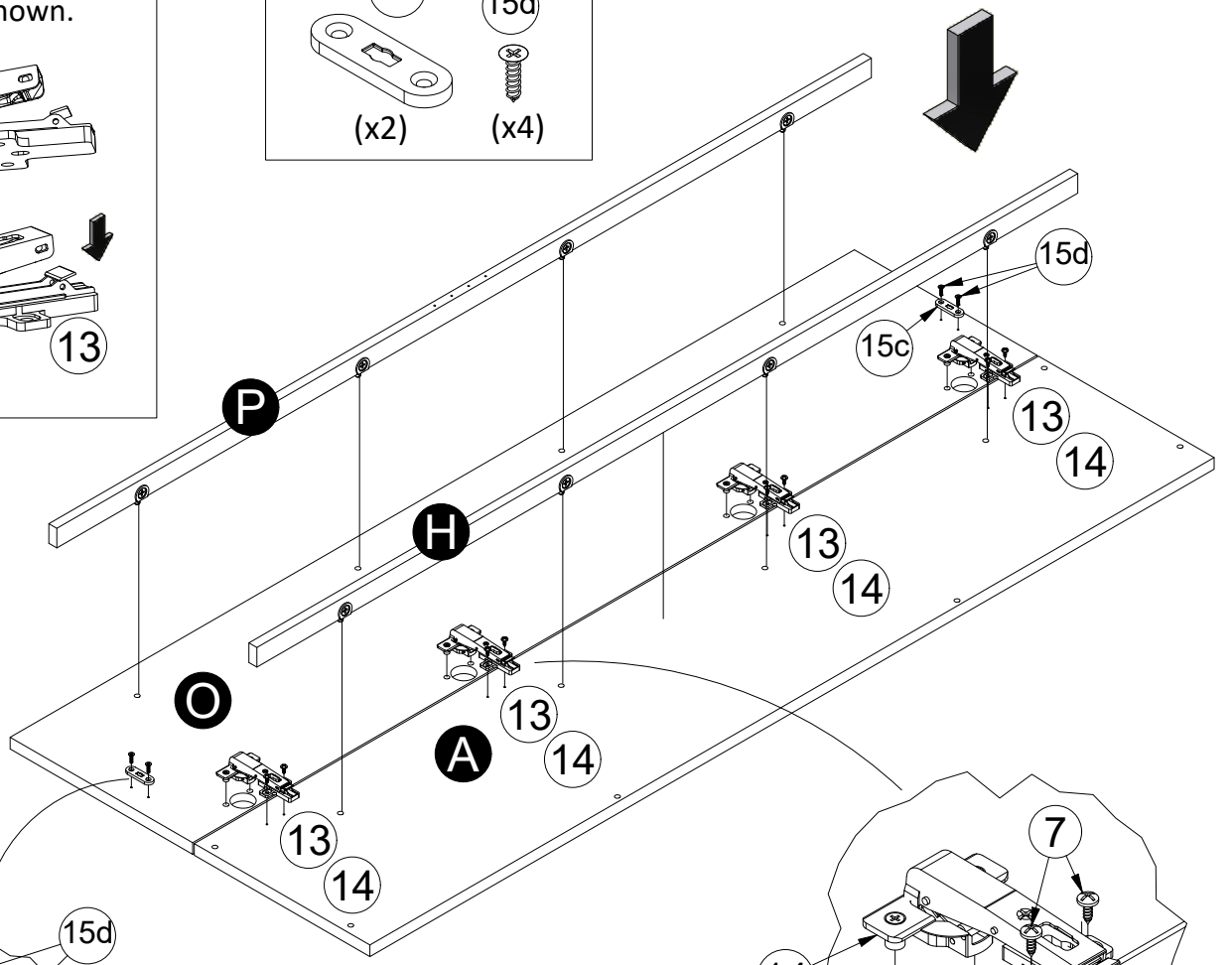
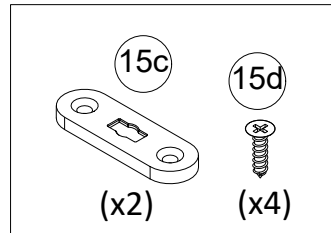
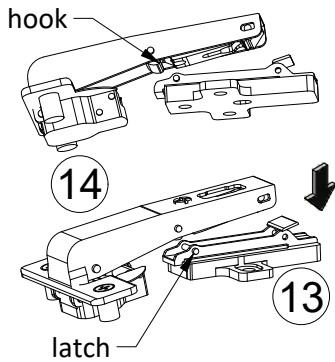

2x

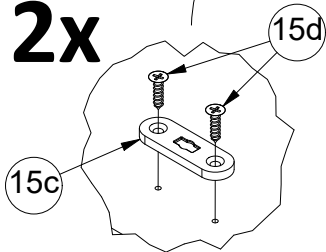

4x

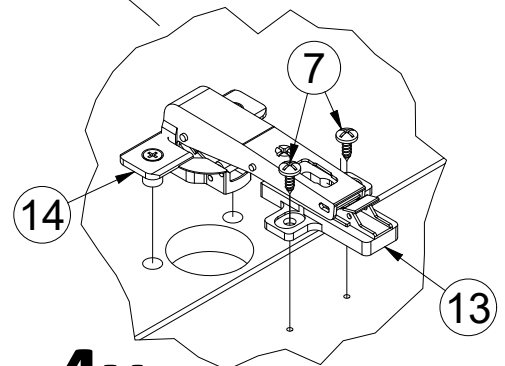

STEP 13

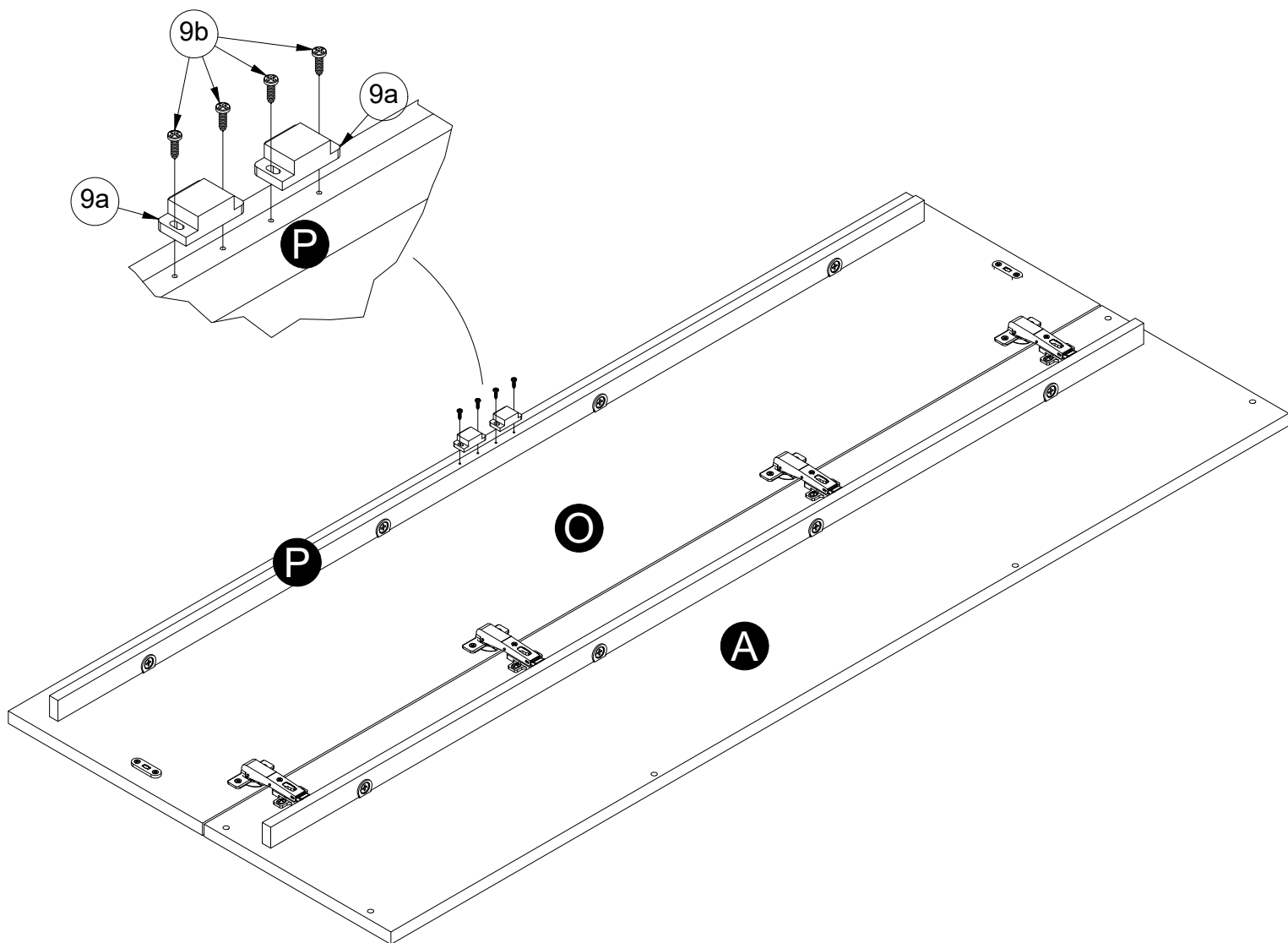
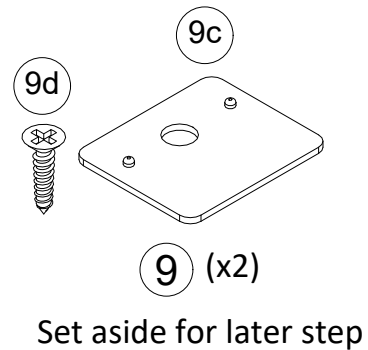
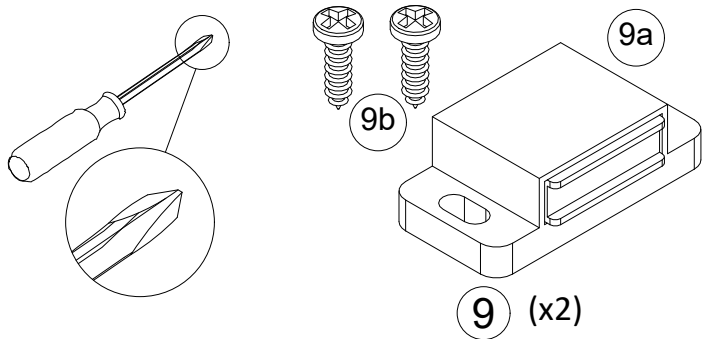

STEP 14

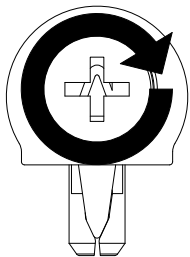

Turn clockwise to lock into place

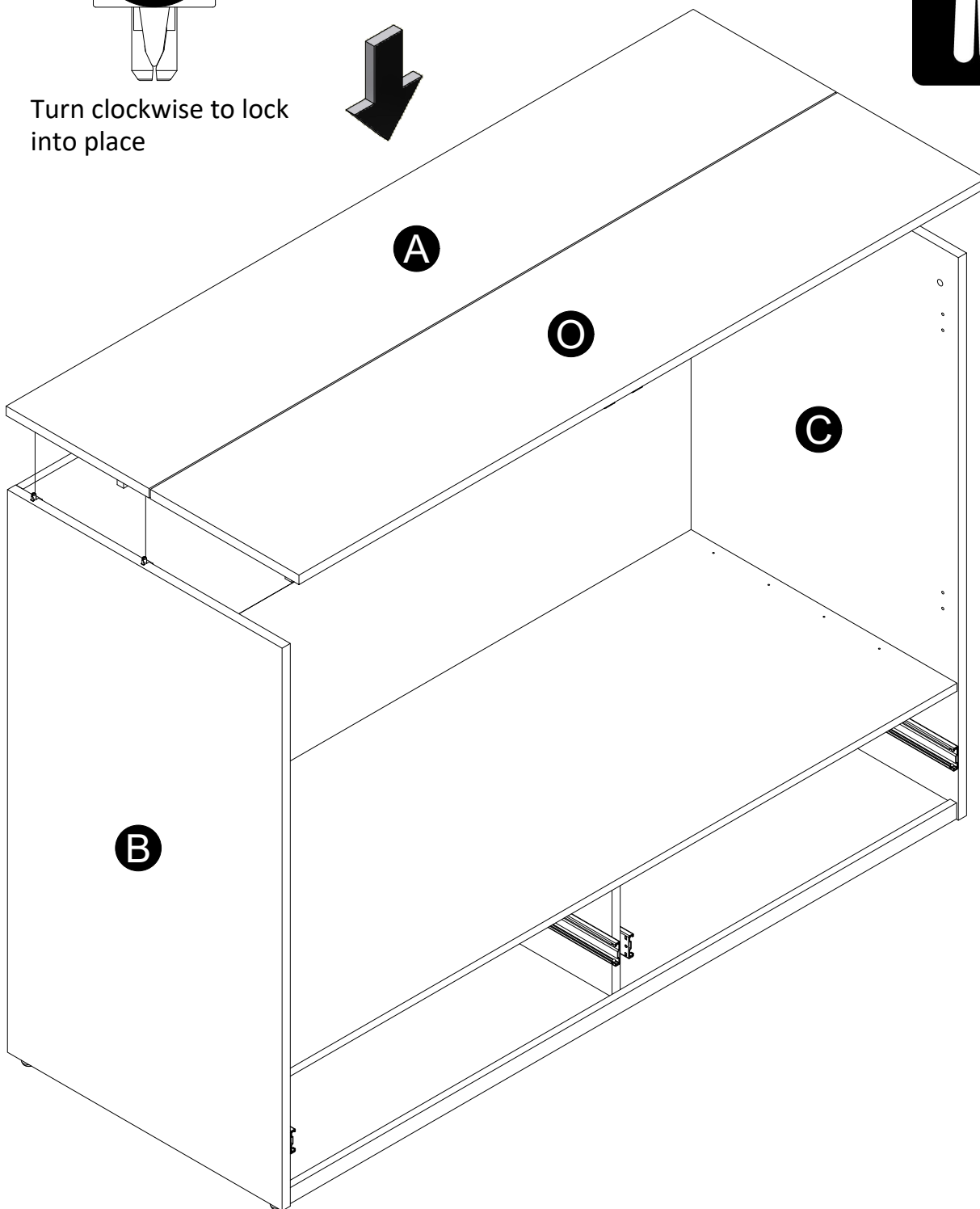
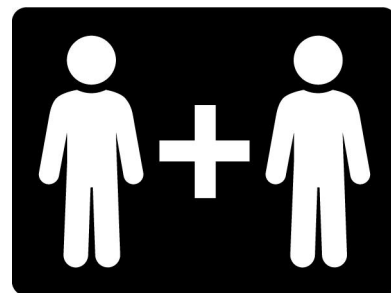
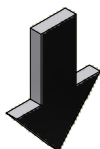

STEP 15

With a helper, move the unit to its final location. Using a level, unscrew the adjustable glides where needed to level unit side to side and front to back.

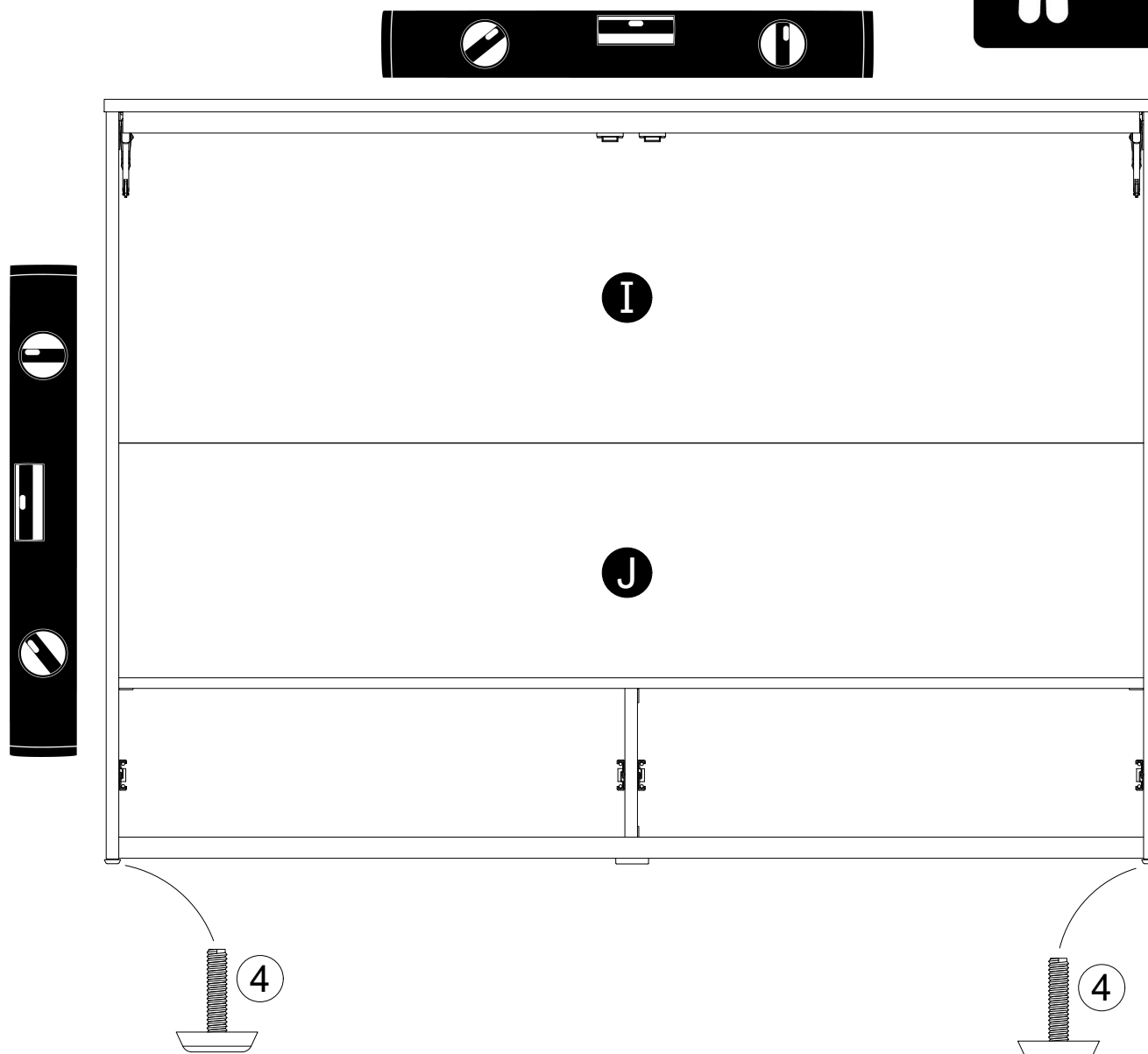
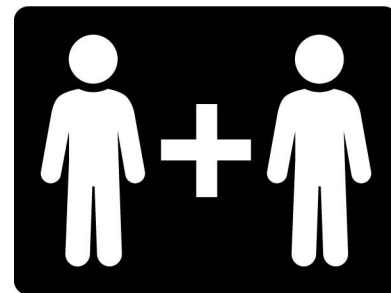

STEP 16

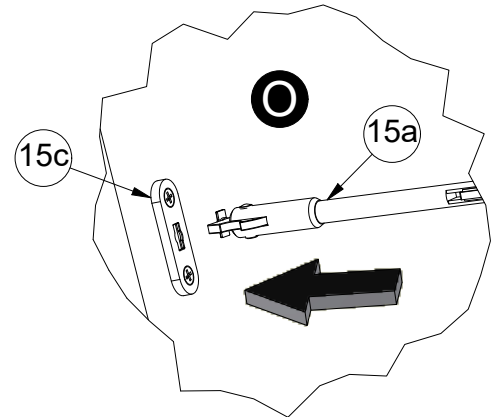
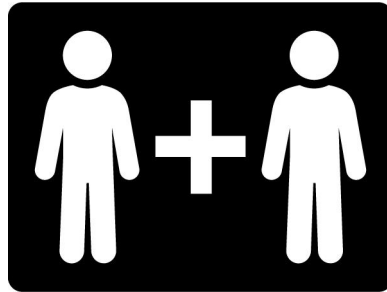
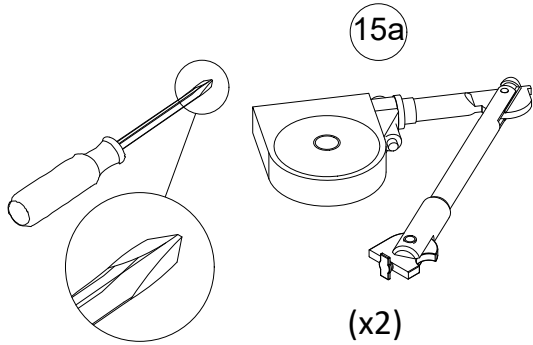

With the Stay extended straight, insert (15a) into (15c) and rotate 90 degrees to lock into place.

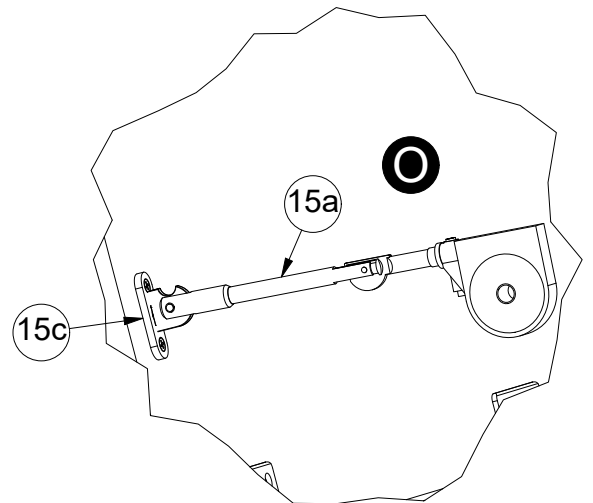
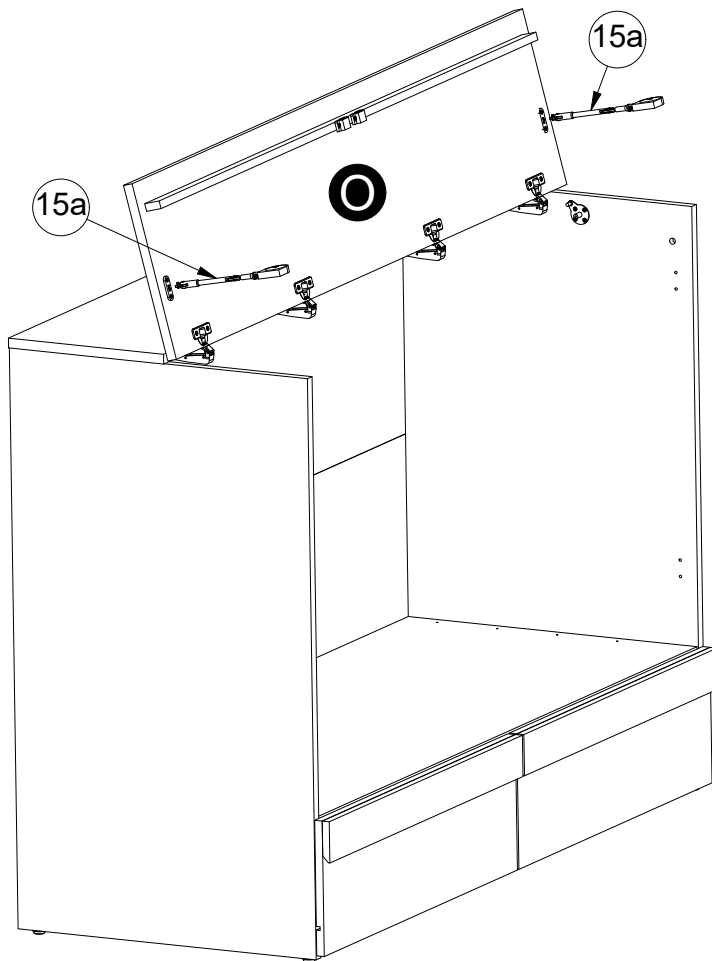

After insertion your Stay should be in this position.

STEP 17

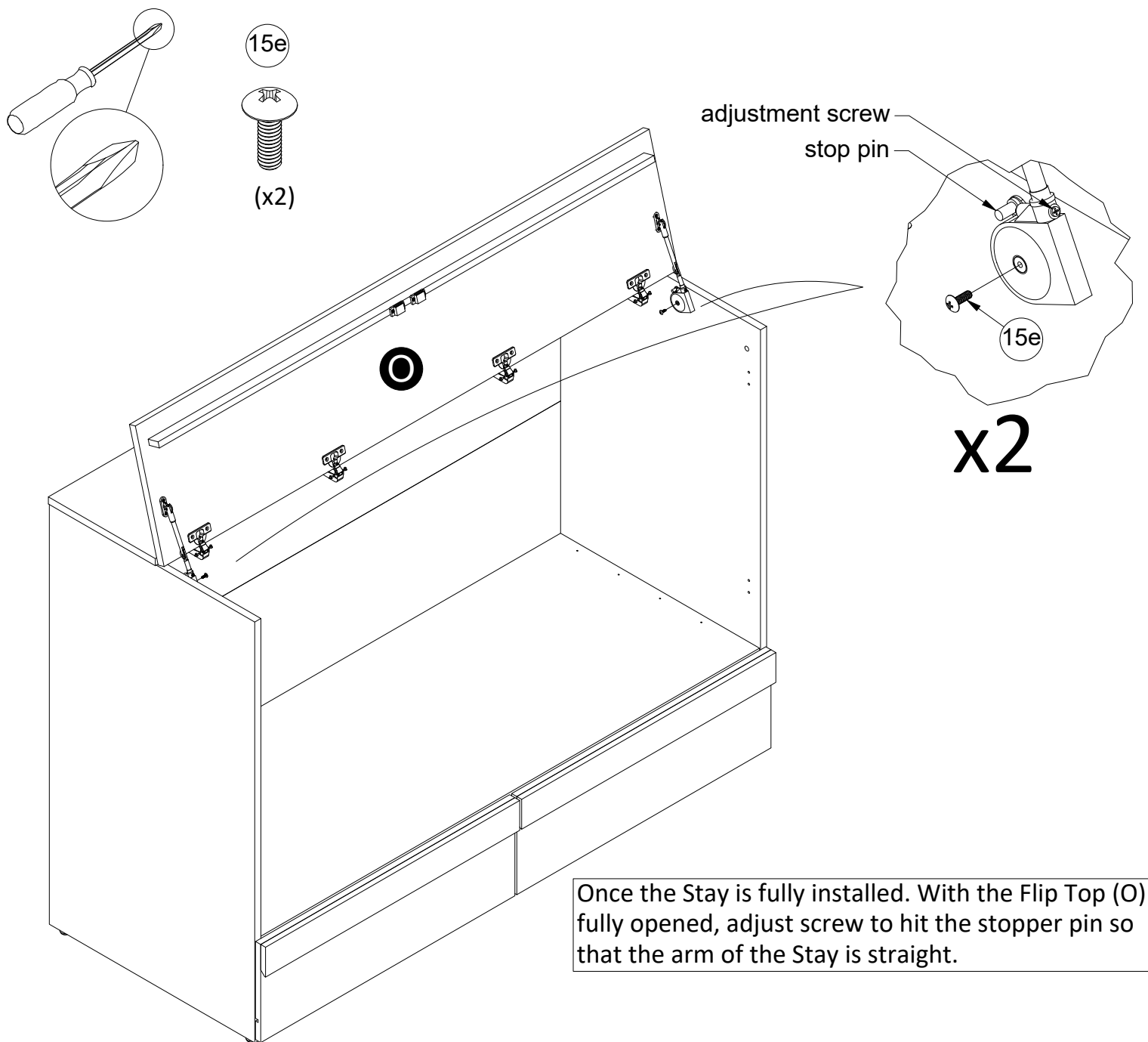

STEP 19

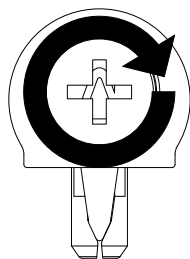
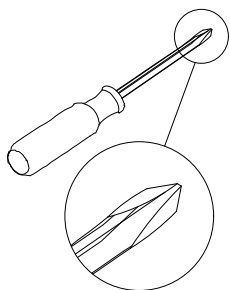

Turn clockwise to lock into place

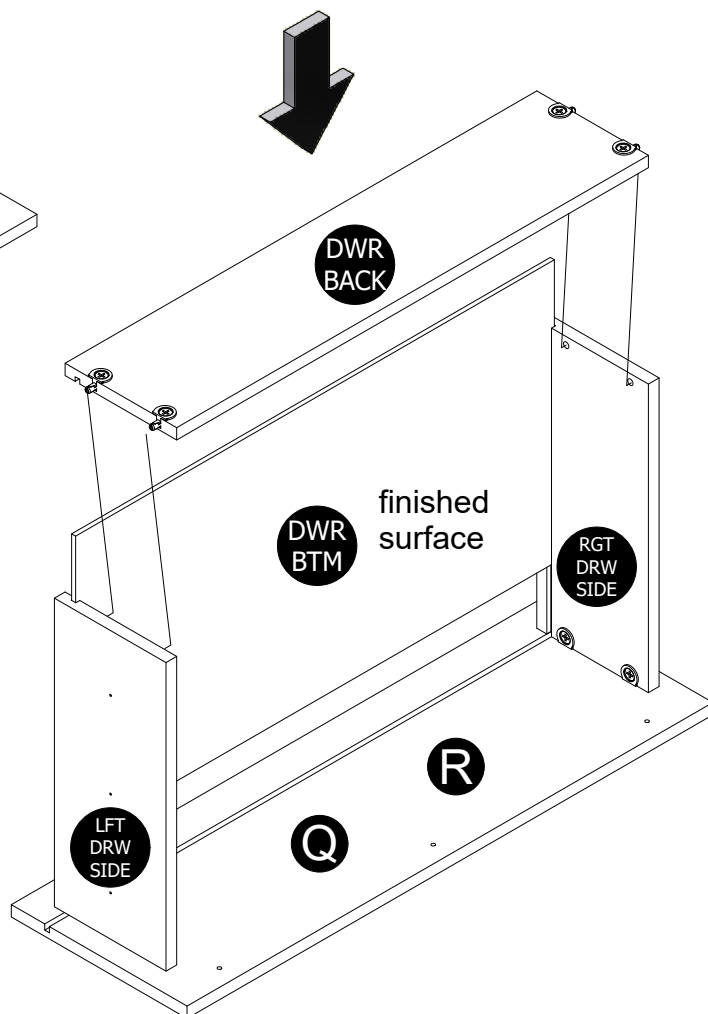
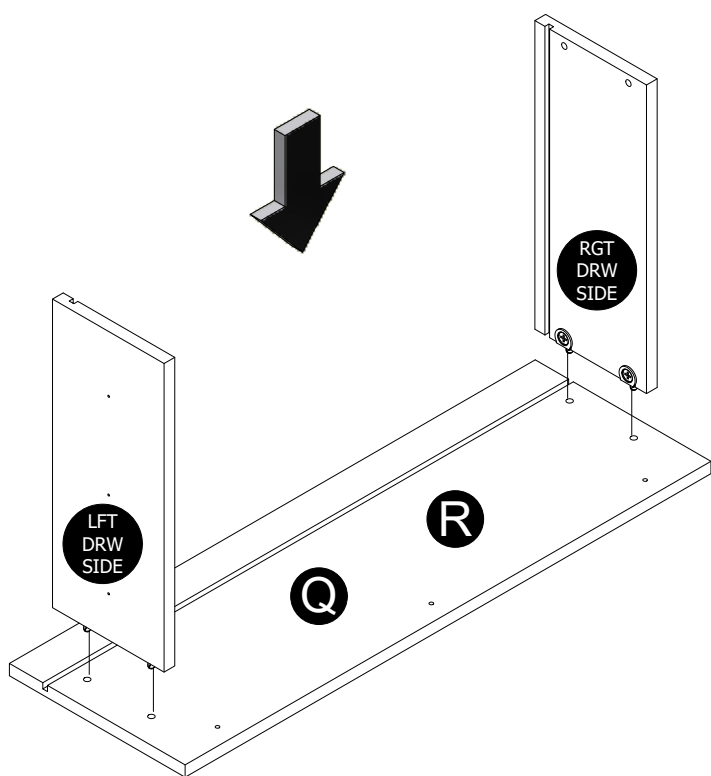

x2

STEP 20

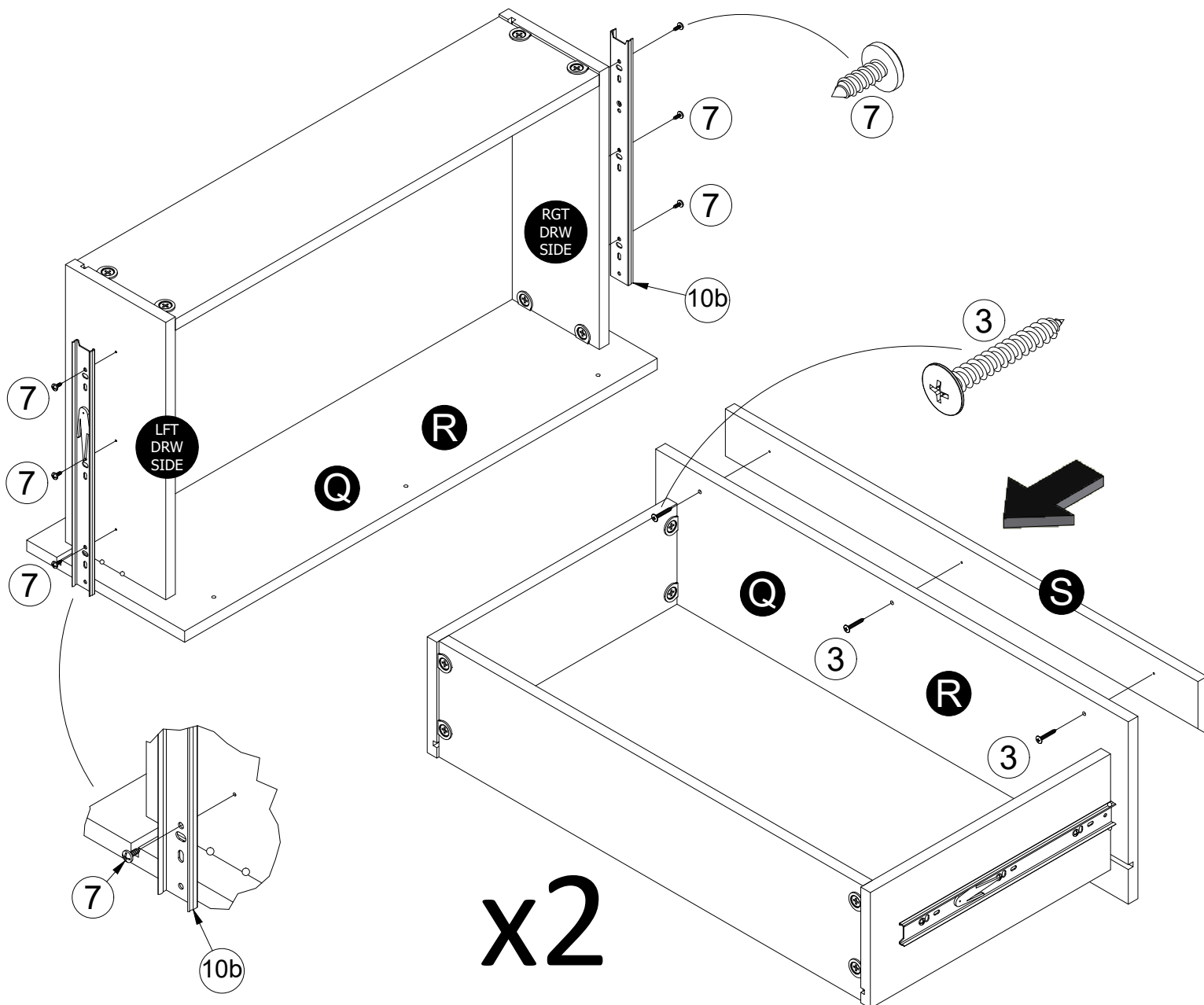
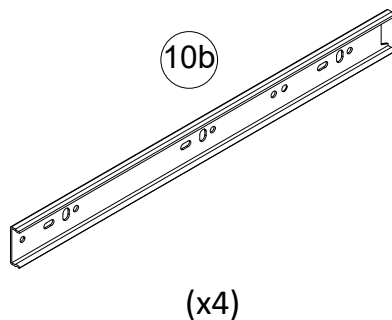
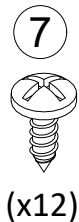
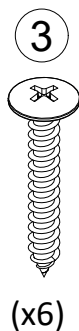
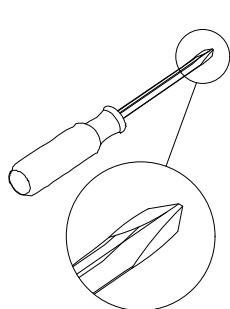

STEP 21

Install drawers by engaging the inner slides (attached to drawer sides) with the outer slides attached to the left side, right side and partition. Push in until plastic lever snaps into the outer slide.

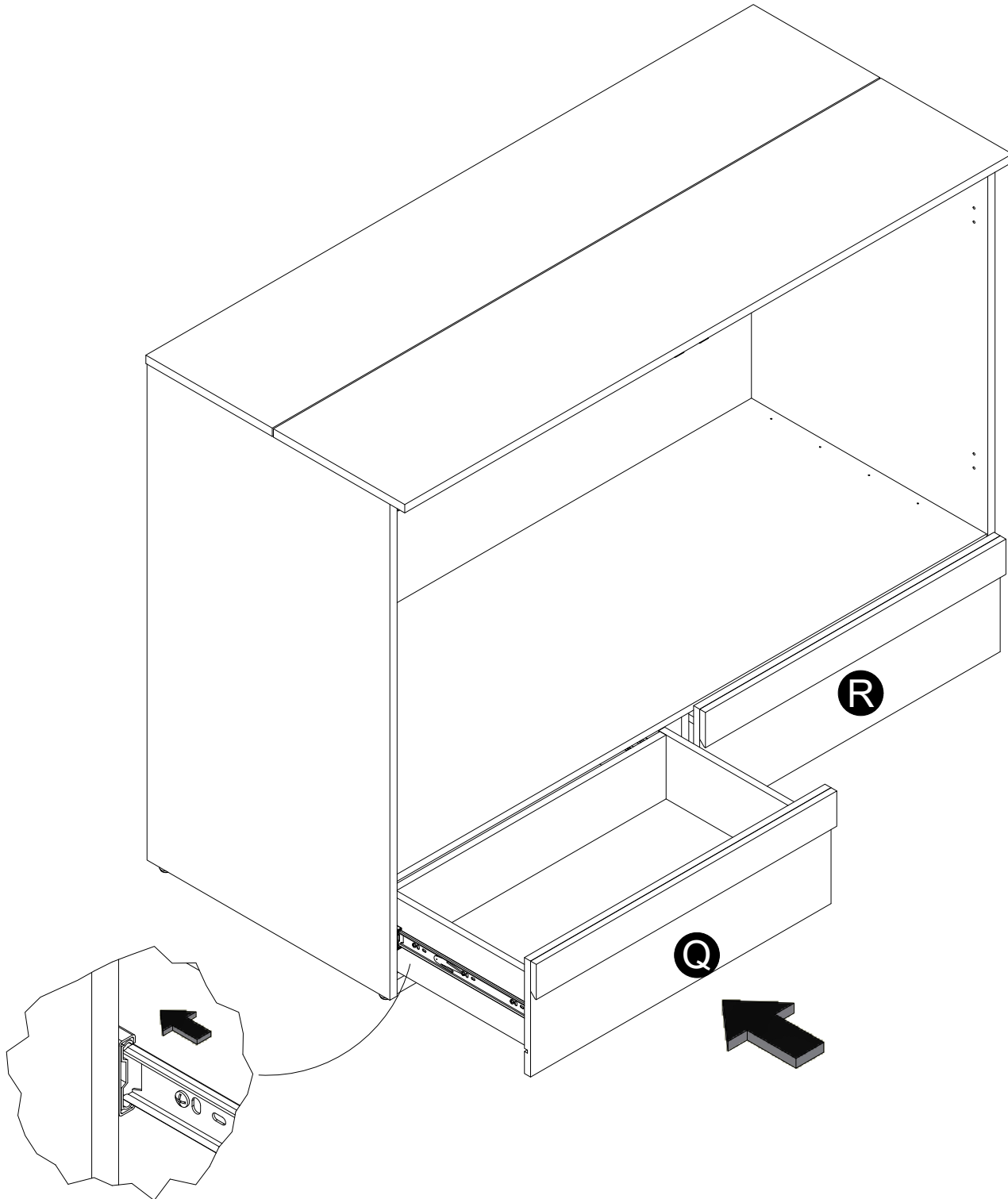

STEP 22

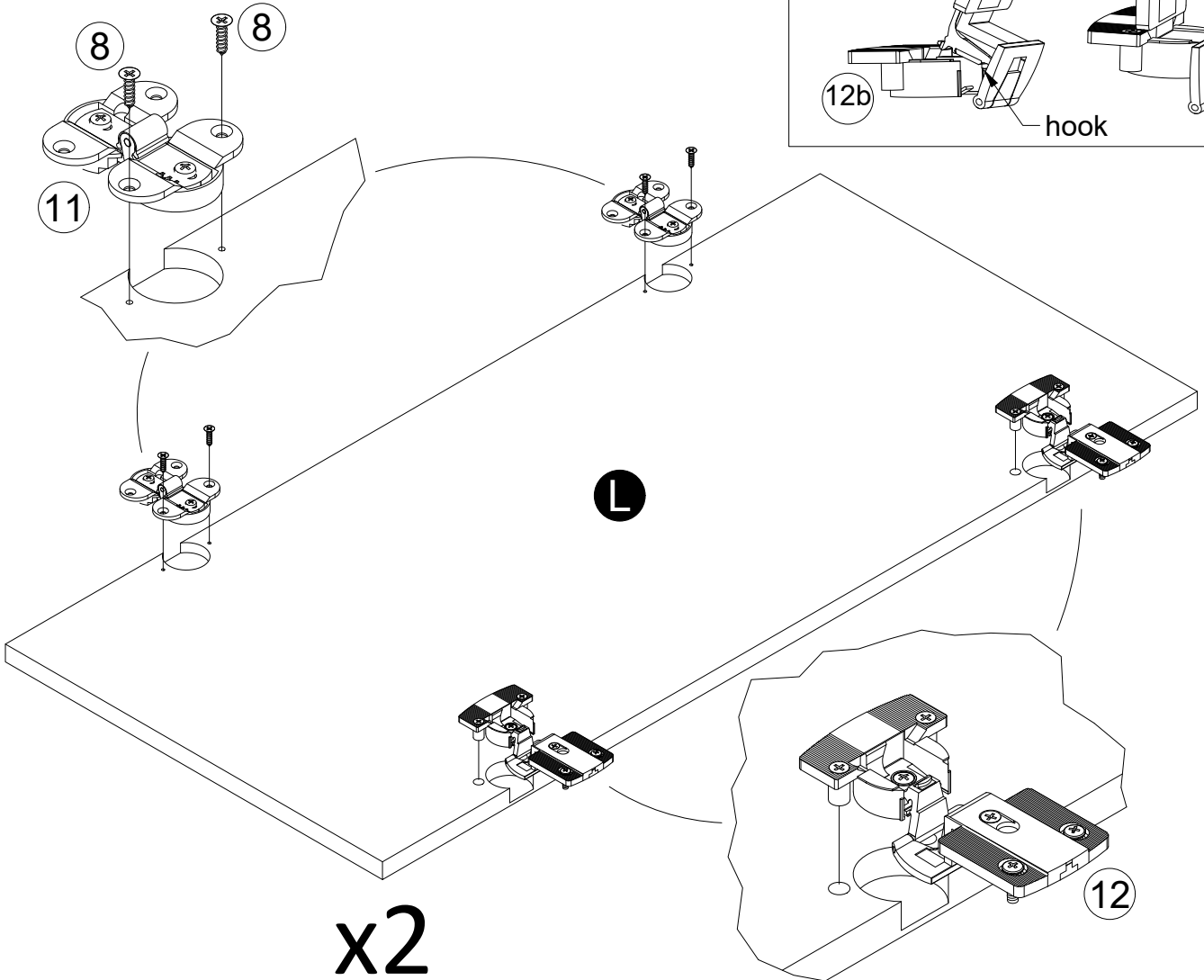
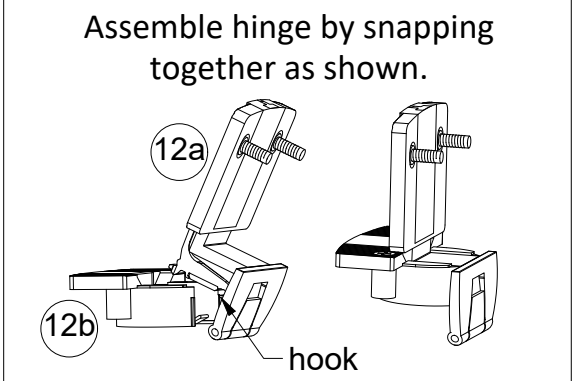
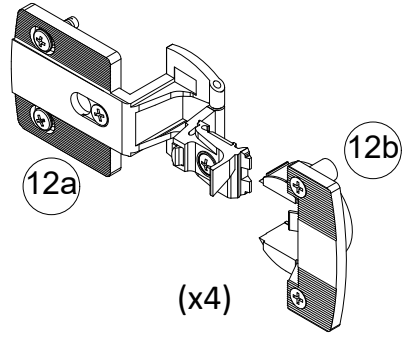
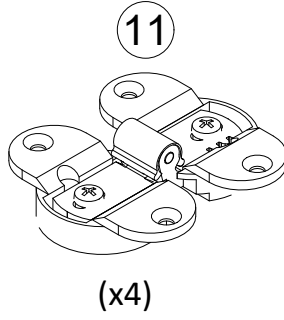
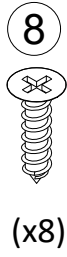
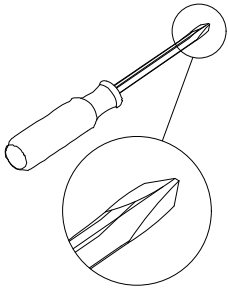

STEP 23

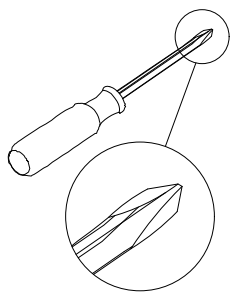

Attach door with hinges as shown.

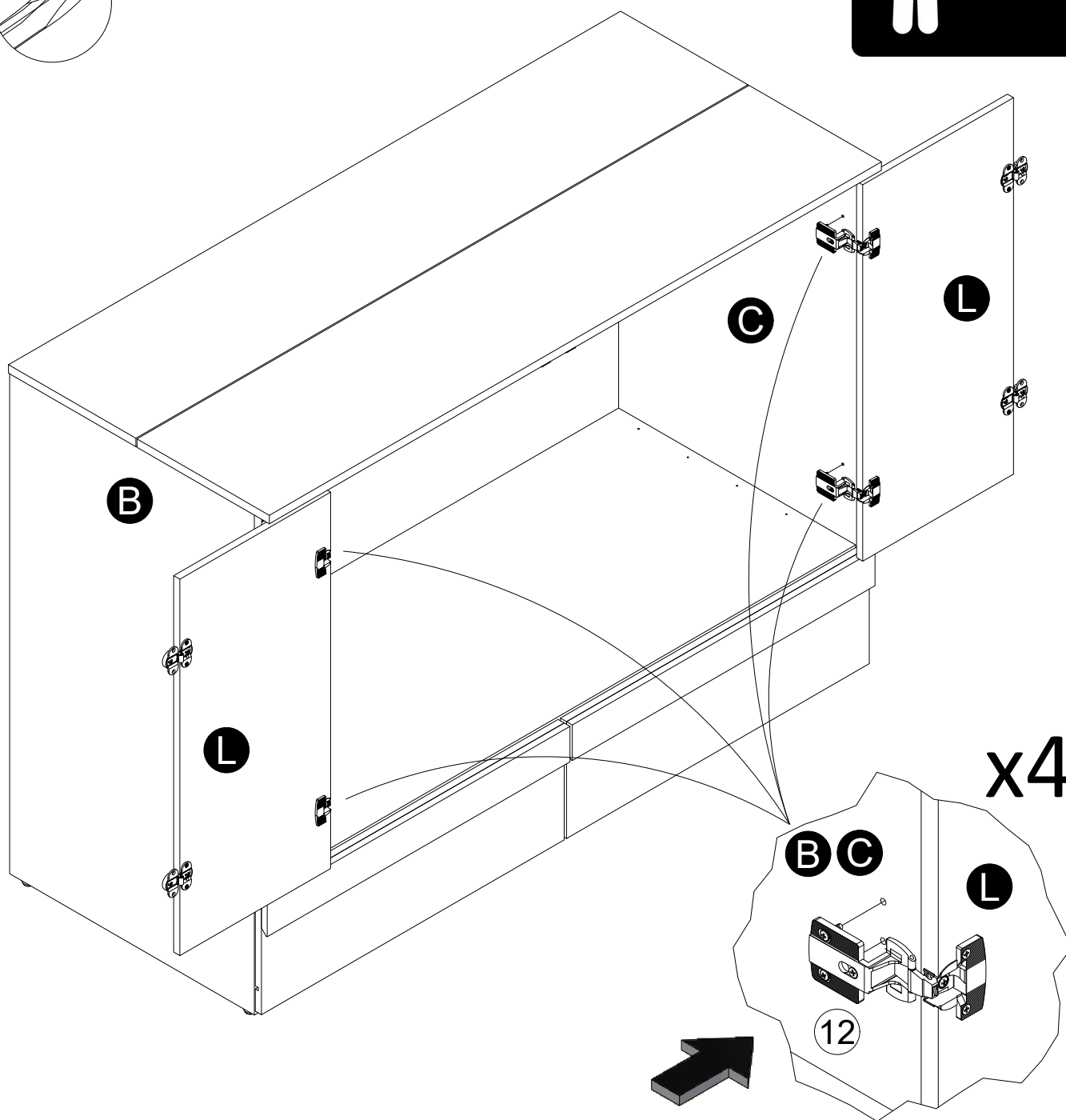
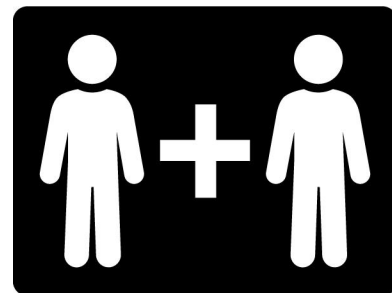

STEP 24

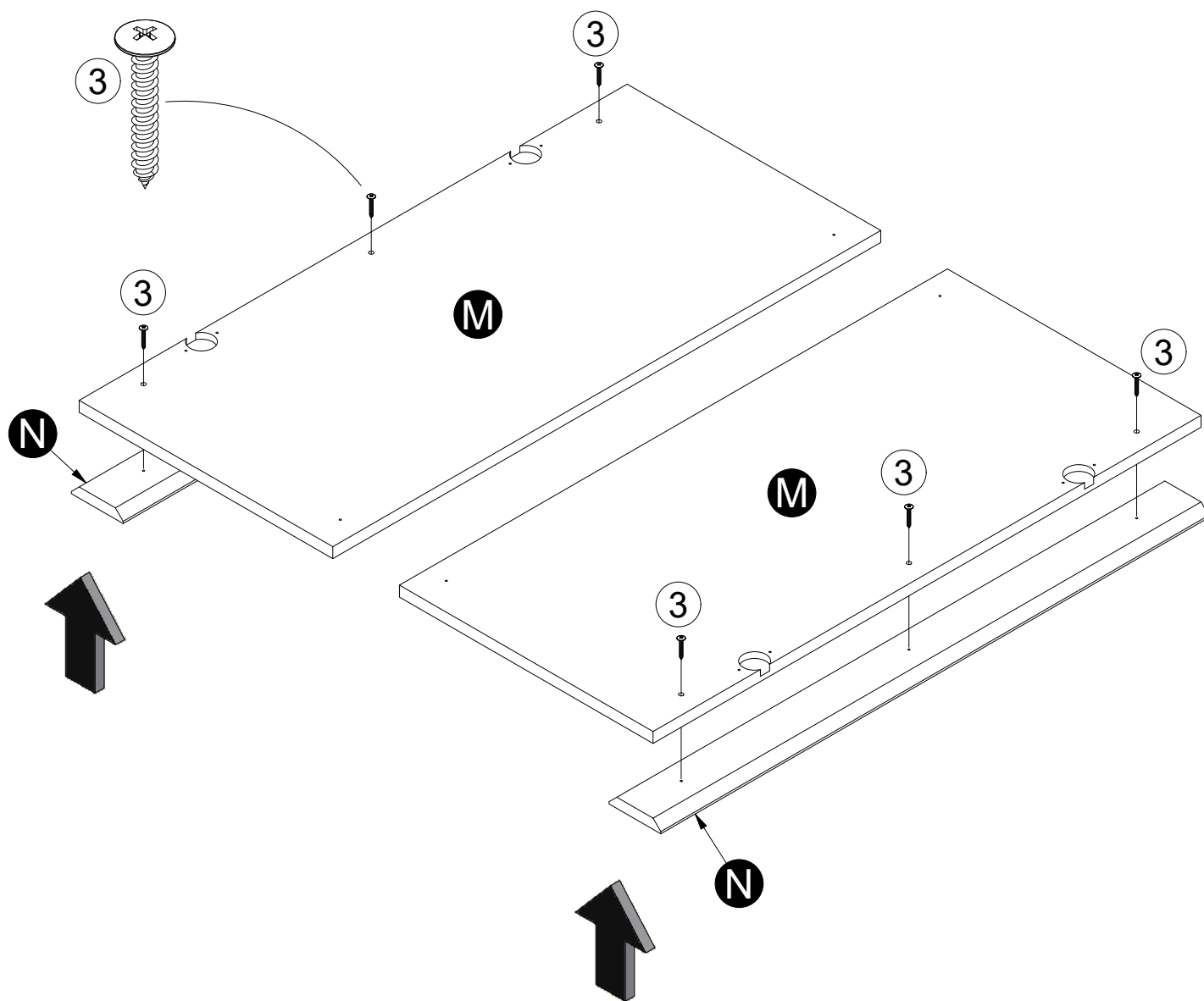
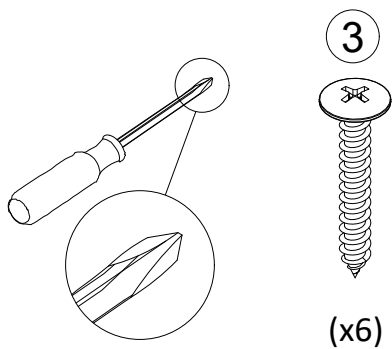

STEP 25

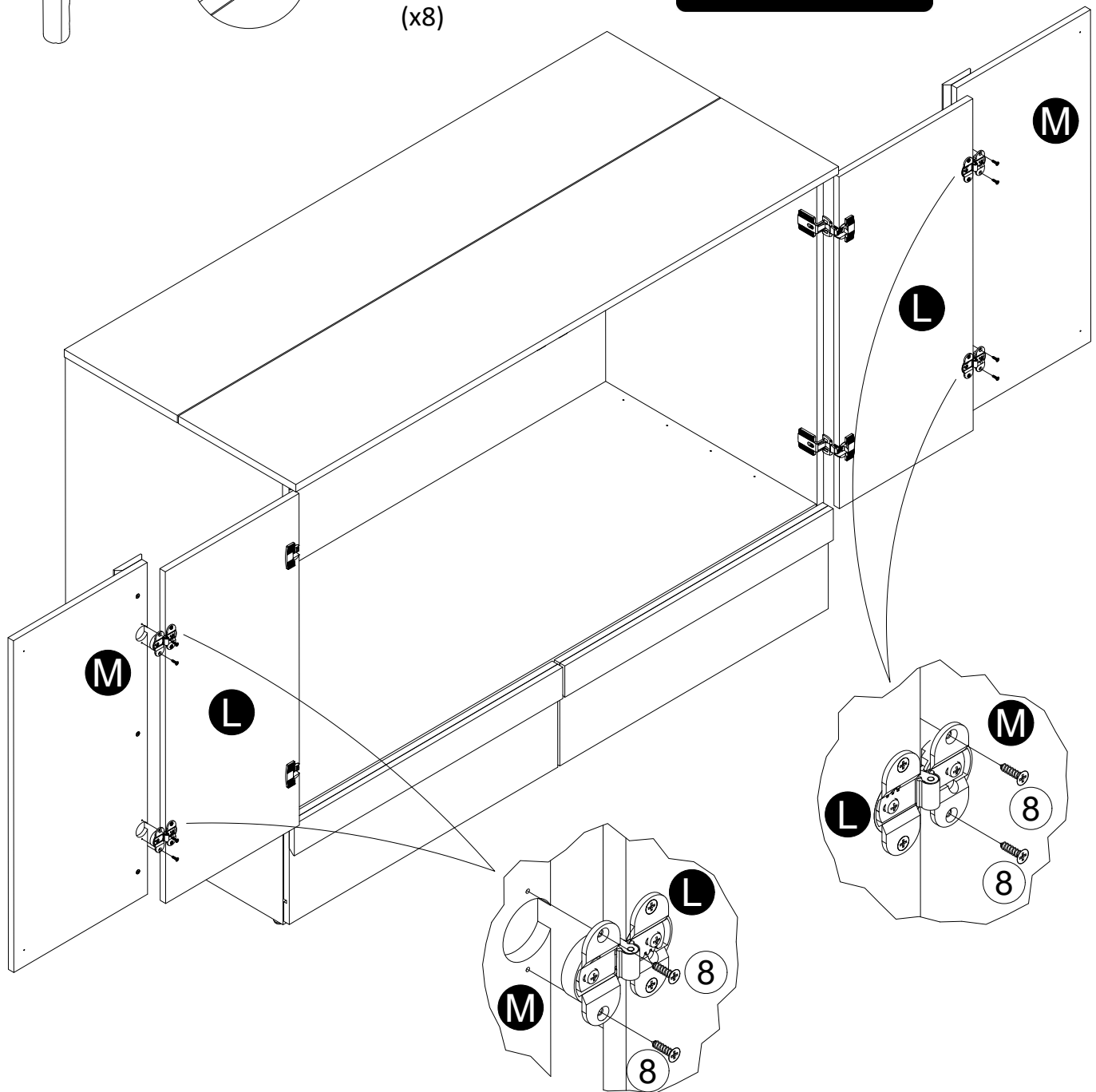
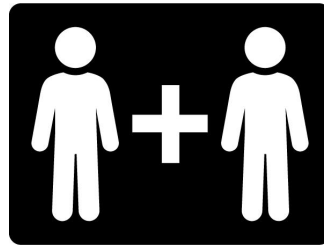
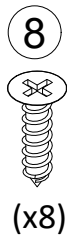
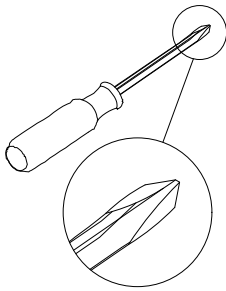
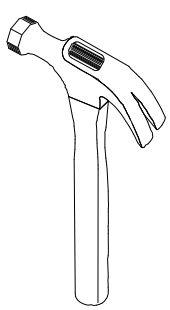

STEP 26

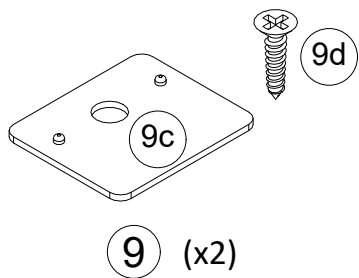
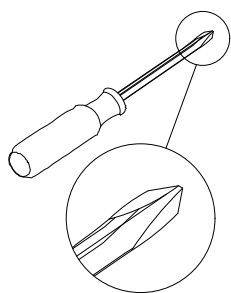

9 (x2)

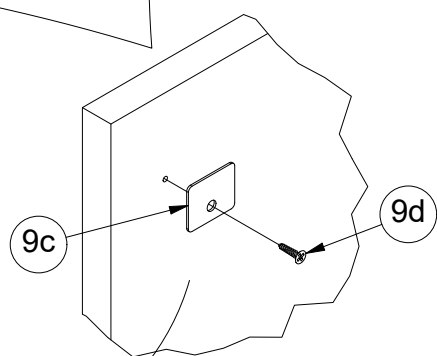
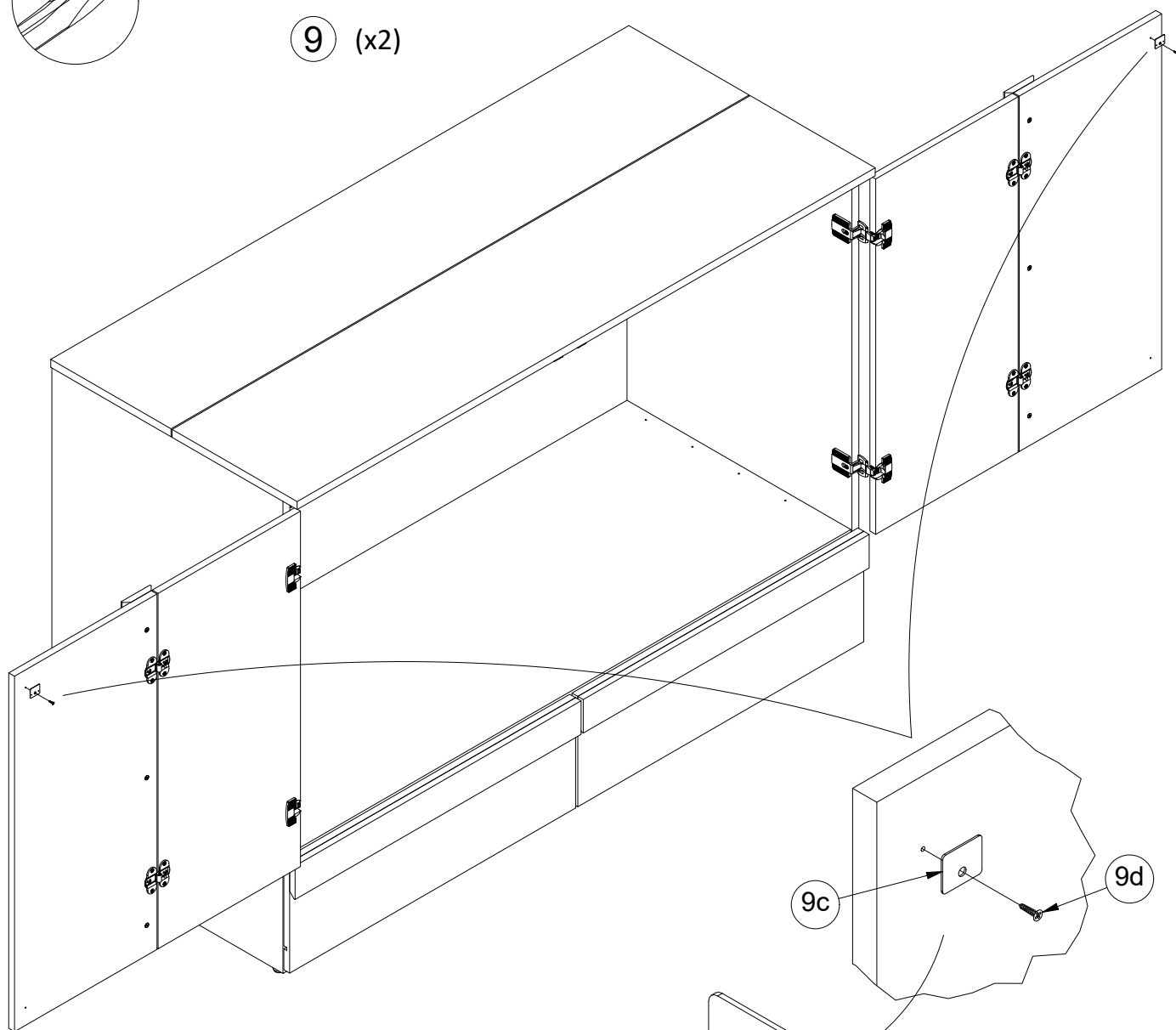

9c

9d

Dimples of (9c) face
towards the door

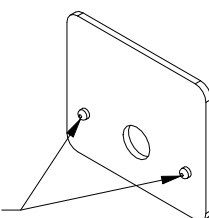

STEP 27

Door & Flip Top Adjustment

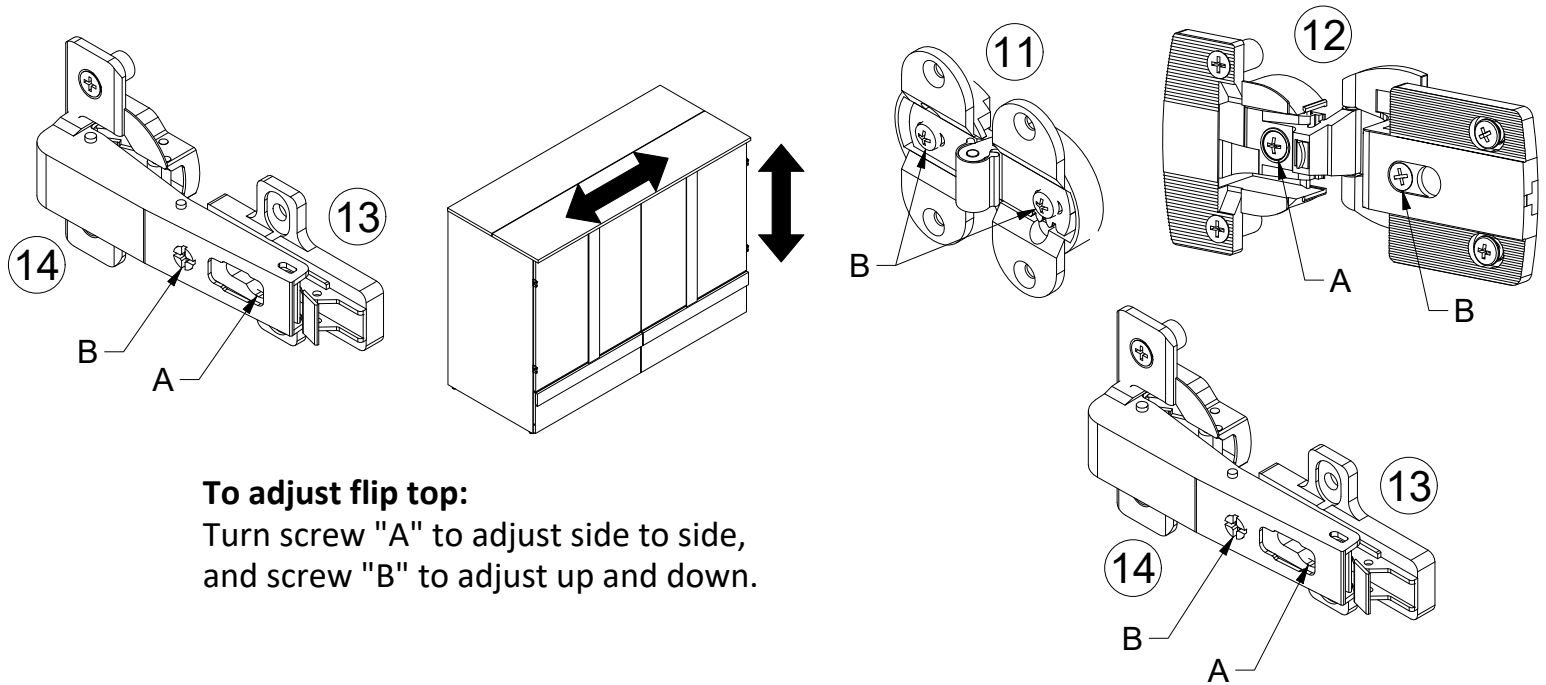

To adjust flip top:

Turn screw "A" to adjust side to side, and screw "B" to adjust up and down.

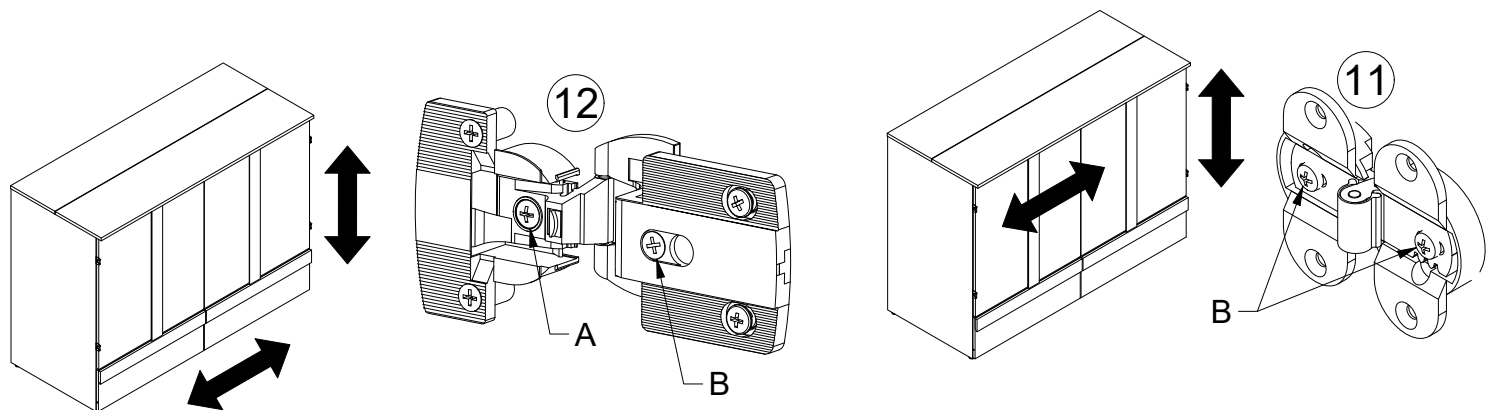

To adjust the Outer Door hinge:

Turn screw "A" to adjust up and down, and screw "B" to adjust side to side.

To adjust Inner Door hinge:

Loosen the screw "B" on one or BOTH sections and tighten once in the proper location.

STEP 28

Hinge holes face front of unit

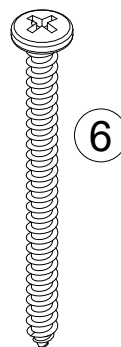
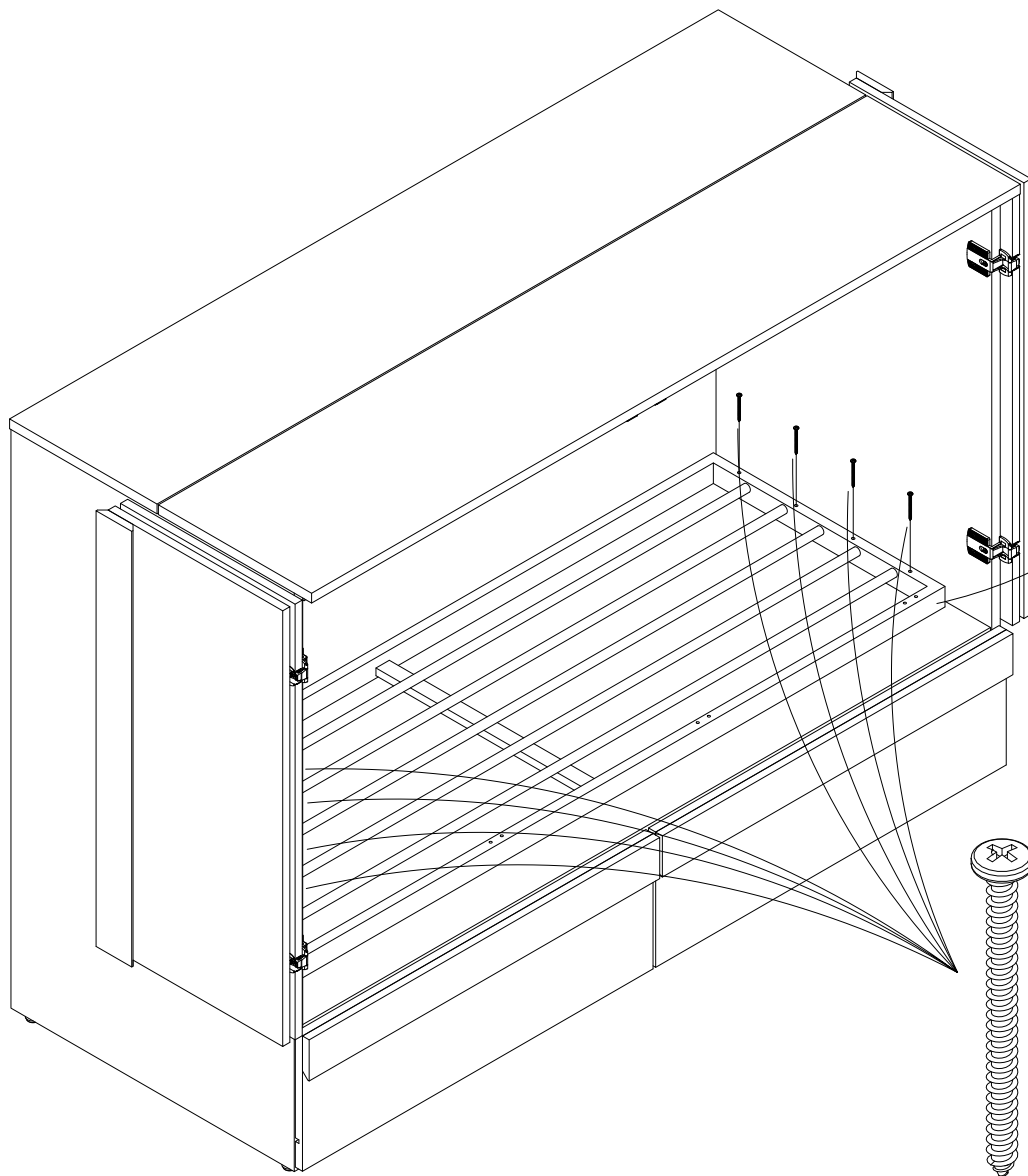
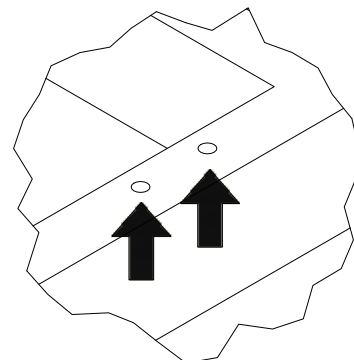
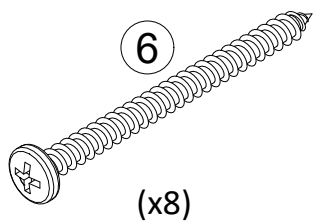

STEP 29

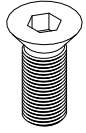

(x32)

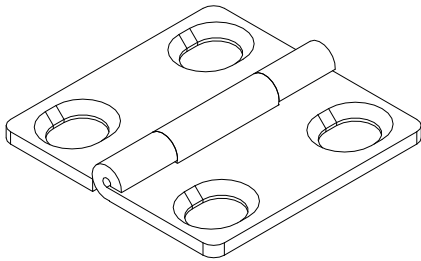

(x8)

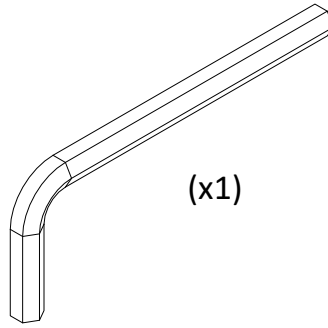

(x1)

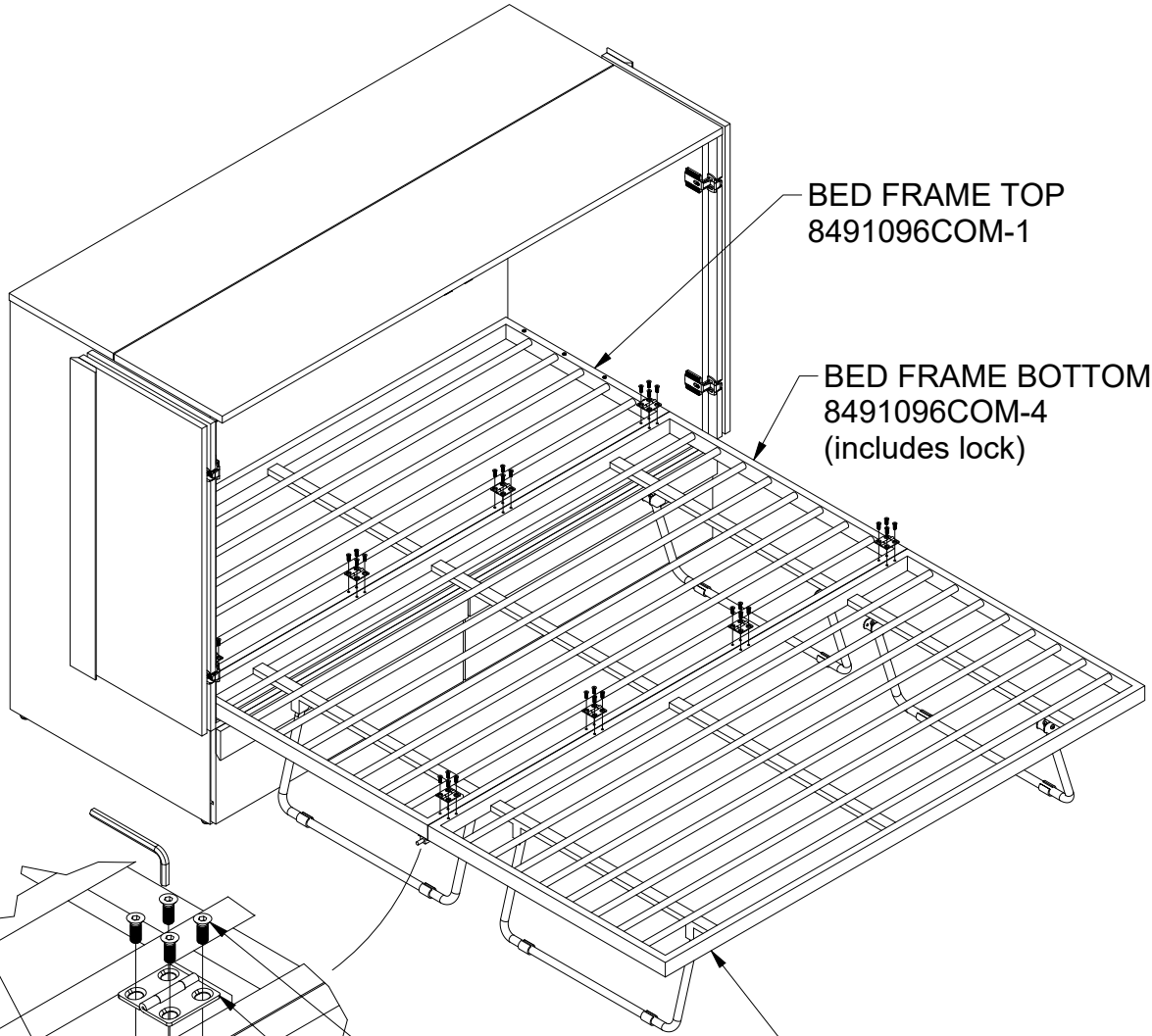

BED FRAME TOP
8491096COM-1

BED FRAME BOTTOM
8491096COM-4
(includes lock)

BED FRAME BOTTOM
8491096COM-4
(includes lock)

SCREW
8491096COM-9

HINGE
8491096COM-3

BED FRAME BOTTOM
8491096COM-2



x8

STEP 30

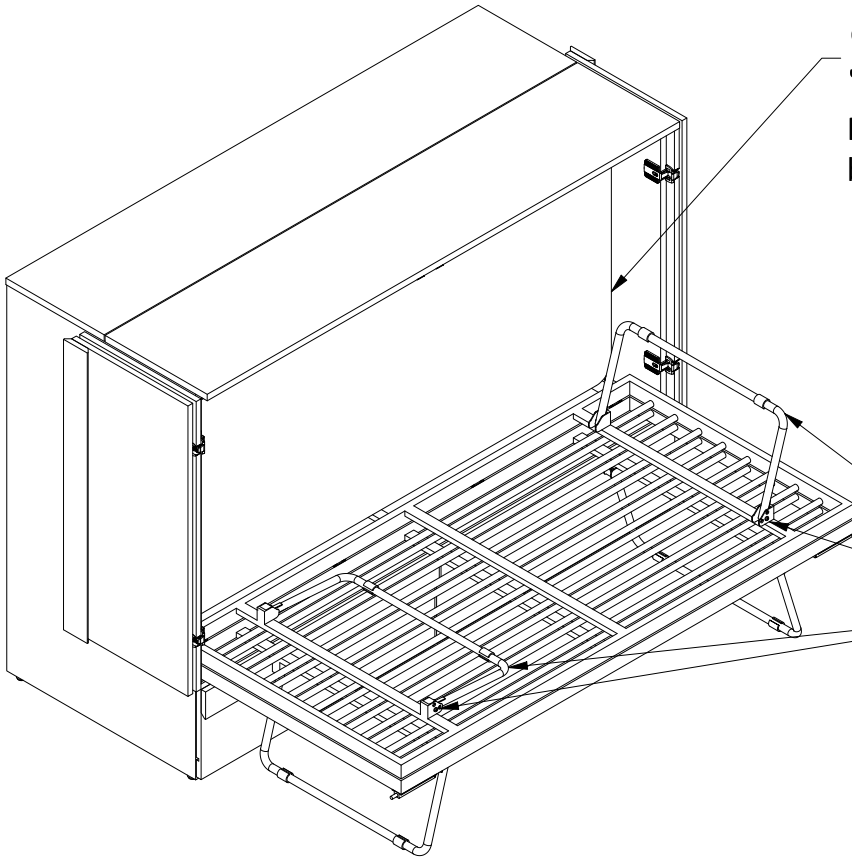

Step 1

Fold up mattress and place behind the mattress frame.

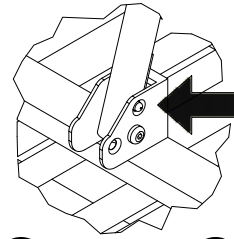

Step 2

Fold up section. Push pin to unlock, fold legs until they lock into place.

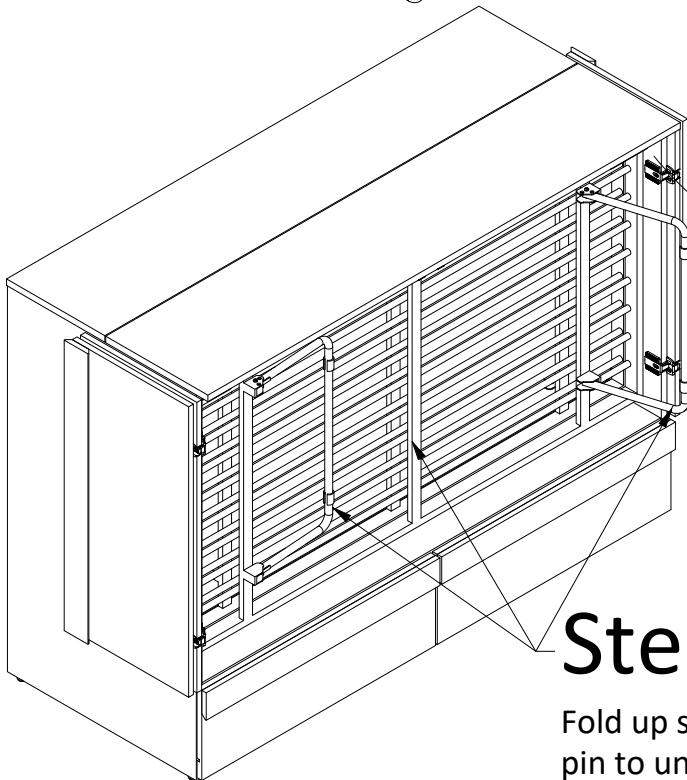

Step 3

Fold up section. Push pin to unlock, fold legs until they lock into place.

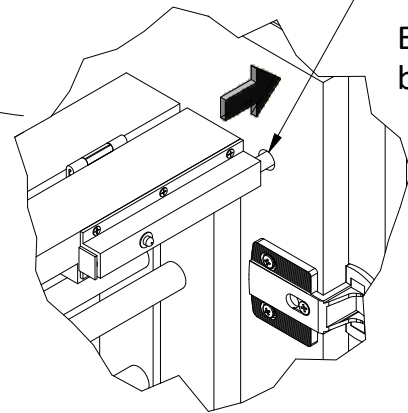

Step 4

Engage lock on both ends.

Maximum Loads

This unit has been designed to support the maximum loads shown. Exceeding these load limits could cause sagging, instability, product collapse, and/or serious injury.

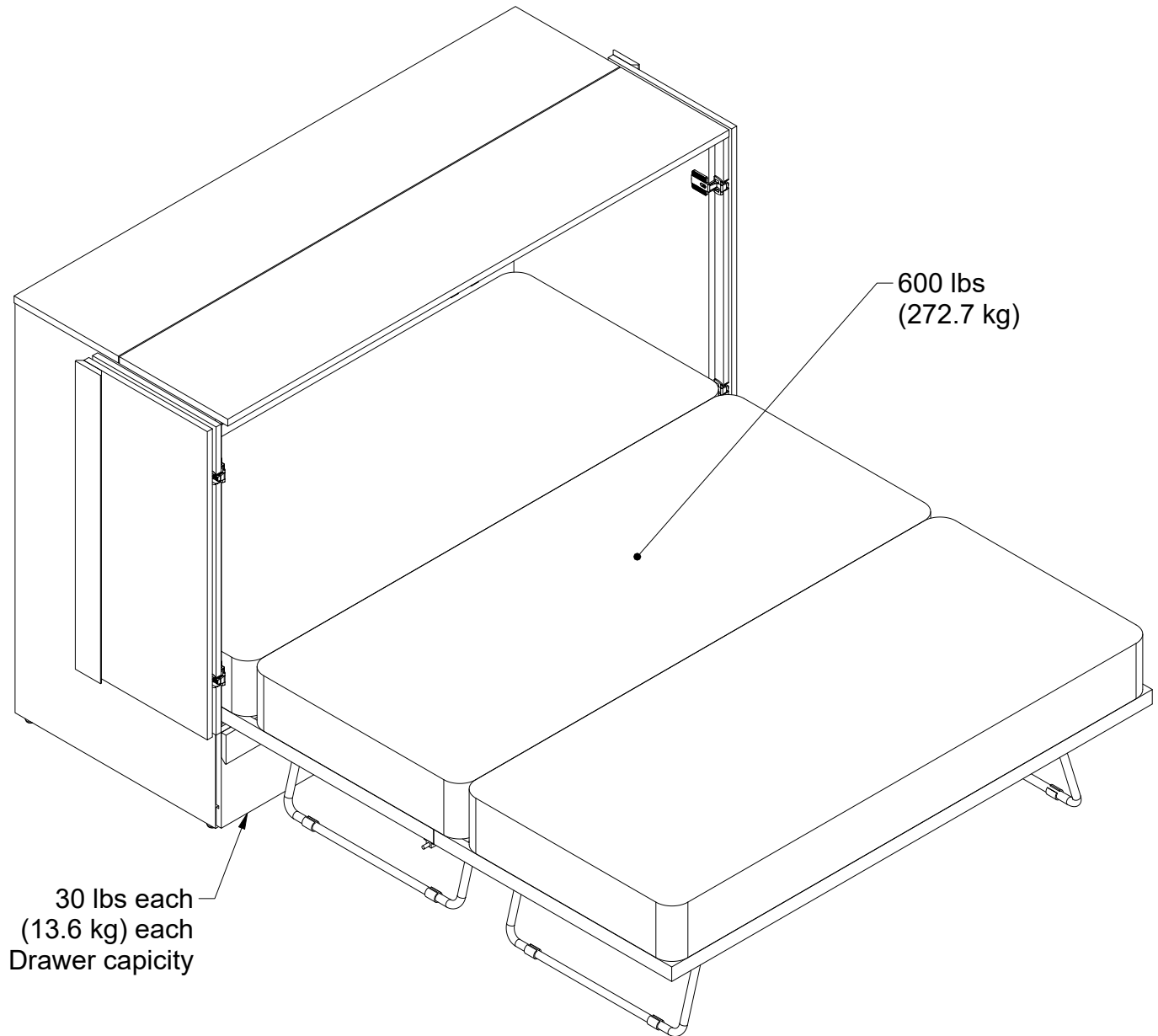

Warning: Risk of injury to persons - do not place a television on this furniture. This furniture is not approved for use with a television.

Español

Cubierta Delantera

Este libro de instrucciones contiene información **IMPORTANTE** de seguridad. Por favor lea y manténgalo para referencia en el futuro.

Asegura tus muebles. Mantén tu hogar y tu familia seguros con el kit de anclaje de pared que se incluye con el producto. Pueden ocurrir lesiones graves o fatales por aplastamiento debido al vuelco de los muebles. **ADVERTENCIA:** El fabricante no asume responsabilidad por una instalación incorrecta o cargas excesivas colocadas en los tornillos o soportes. Este anclaje de pared no es un sustituto de la supervisión adecuada de un adulto.

Consejos Útiles (página 2)

- Abre tu artículo en el área donde planeas mantenerlo para evitar levantar objetos pesados en exceso.
- Identifica, clasifica y cuenta las piezas antes de intentar el ensamblaje.
- Los pasadores de compresión se golpean ligeramente con un martillo.
- NO uses productos químicos fuertes ni limpiadores abrasivos en este artículo.
- Nunca empujes, jales o arrastres tus muebles

Antes de Que Empieces (página 3)

- Lea cuidadosamente cada paso y siga el orden correcto
- Separar y contar todas sus piezas y hardware
- Dése suficiente espacio para el proceso de ensamble
- Tenga las siguientes herramientas: destornillador de cabeza plana, #2 cabeza Phillips
Destornillador y martillo
- Precaución: Si usa un taladro electrónico o un destornillador eléctrico para atornillar, por favor asegúrese que deje de atornillar cuando el tornillo este apretado. Fallar hacer esto puede causar barrer el tornillo.

Página 4

Tenga en cuenta: Es posible que deba golpear ligeramente las clavijas de madera en los orificios durante el proceso de ensamblaje.

Página 11

Su unidad viene con correderas de cajón ensambladas. Para cada corredera, extienda la corredera como se muestra y presione el botón de liberación para quitar la corredera interna. Guarde la corredera interna para más tarde. Para los pasos 1, 2 y 7, deberá fijar la corredera externa a los paneles. Mientras desliza la corredera central, localice los agujeros en los paneles con los orificios de acceso en la corredera central y fíjelos con tornillos.

Palanca de liberación, Corredera interna, Corredera central, Corredera externa, Fije utilizando los agujeros indicados.

Español

Página 12, 13 & 19 - Verifique que el conector esté completamente colocado y recto. Observe la orientación de 15b en (B & C). Consulte la página 11 para las instrucciones de instalación de la diapositiva.

Página 18 - Gire en sentido contrario a las agujas del reloj o Lock en su lugar. Superficie superior, superficie inferior.

Página 23 - Ensambla la bisagra al presionar las partes juntas, como se muestra.

Página 24 - A un lado.

Página 26 - Con la ayuda de alguien, mueve la unidad a su ubicación final. Utilizando un nivel, desenrosca los deslizadores ajustables donde sea necesario para nivelar la unidad de lado a lado y de adelante hacia atrás.

Página 27 - Con el Stay extendido en línea recta, inserta (15a) en (15c) y gira 90 grados para bloquearlo en su lugar. Después de la inserción, tu Stay debería estar en esta posición.

Página 28 - Goupille d'arrêt de vis de réglage, goupille d'arrêt. Una vez que el soporte esté completamente instalado. Con la parte superior abatible (O) completamente abierta, ajusta el tornillo para que golpee el pasador de tope y el brazo del soporte quede recto.

Página 30 - Superficie terminada.

Página 32 - Instala los cajones enganando las guías internas (unidas a los lados del cajón) con las guías externas unidas al lado izquierdo, derecho y la partición. Empuja hasta que la palanca de plástico encaje en la guía externa.

Página 34 - Adjunta la puerta con bisagras como se muestra.

Página 37 - Hoyuelos de la cara (9c) hacia la puerta.

Página 38 - Ajuste de la puerta y la tapa abatible. Para ajustar la tapa abatible: Gira el tornillo "A" para ajustar de lado a lado, y el tornillo "B" para ajustar hacia arriba y hacia abajo. Para ajustar la bisagra de la puerta exterior: Gira el tornillo "A" para ajustar hacia arriba y hacia abajo, y el tornillo "B" para ajustar de lado a lado. Para ajustar la bisagra de la puerta interior: Afloja el tornillo "B" en una o AMBAS secciones y apriétalo una vez en la ubicación adecuada

Página 39 - Los orificios de las bisagras miran hacia la parte frontal de la unidad.

Página 40 - Ubicación del pestillo (ambos lados).

Página 41 - Paso 1: Dobra el colchón y colócalo detrás del marco del colchón. Paso 2: Dobra la sección. Presiona el pasador para desbloquear y pliega las patas hasta que encajen en su lugar. Paso 3: Dobra la sección. Presiona el pasador para desbloquear y pliega las patas hasta que encajen en su lugar. Paso 4: Engage el seguro en ambos extremos.

Español

Página 42

CARGA MAXIMA

Esta unidad ha sido diseñada para soportar la carga máxima anotada. El exceder estos límites puede causar inestabilidad, colapsarse y/o causar serias lesiones.

ADVERTENCIA: Riesgo de lesiones a las personas - no coloque un televisor sobre muebles. Este mueble no está aprobado para su uso con un televisor.

Página 43

Registre su producto para recibir lo siguiente:

- * Detalles de nuevas tendencias - Vistazo a lo nuevo
- * Encuestas - alec su voz entre su comunidad
- * Códigos de ofertas y descuentos exclusivos
- * Fácil y rápido servicio de partes de remplace

Clasificación de 5 estrellas

Visite el sitio web de su tienda local, califique su comprado y denos sus comentarios!

Français

Couverture Avant

CE LIVRET D'INSTRUCTION CONTIENT DES INFORMATIONS **IMPORTANTES** SUR LA SÉCURITÉ. VEUILLEZ LIRE ET GARDER POUR UNE RÉFÉRENCE FUTURE

Sécurisez vos meubles. Protégez votre maison et votre famille avec le kit d'ancrage mural inclus avec le produit. Des blessures graves ou mortelles par écrasement peuvent survenir en cas de basculement des meubles. **AVERTISSEMENT** : Le fabricant décline toute responsabilité en cas d'installation incorrecte ou de charges excessives placées sur les vis ou les supports. Cet ancrage mural ne remplace pas une surveillance adéquate des adultes.

Astuces Utiles (page 2)

- Ouvrez votre article dans la zone où vous prévoyez de le conserver pour éviter de soulever des objets lourds de manière excessive.
- Identifiez, trie et comptez les pièces avant d'essayer l'assemblage.
- Les chevilles de compression sont légèrement enfoncées à l'aide d'un marteau.
- N'utilisez PAS de produits chimiques agressifs ni de nettoyeurs abrasifs sur cet article.
- Ne poussez jamais, ne tirez jamais et ne traînez jamais vos meubles

Avant de Commencer (page 3)

- Lisez attentivement chaque étape et suivez le bon ordre
- Séparez et comptez toutes vos pièces et matériaux
- Donnez-vous suffisamment de place pour l'assemblage
- Avoir les outils suivants: tournevis à tête plate, #2 tournevis Phillips, et Marteau
- Attention: Si vous utilisez une perceuse électrique ou un tournevis électrique pour visser, veillez à ralentir et arrêter lorsque la vis est bien serrée. Le non-respect de cette consigne peut endommager la vis.

Page 4

Veillez noter: vous devrez peut-être tapoter légèrement les chevilles en bois dans les trous pendant votre processus d'assemblage.

Page 11

Votre unité est livrée avec des glissières de tiroir assemblées. Pour chaque glissière, étendez-la comme indiqué et appuyez sur le bouton de libération pour retirer la glissière intérieure. Mettez la glissière intérieure de côté pour plus tard. Pour les étapes 1, 2 et 7, vous fixerez la glissière extérieure aux panneaux. Tout en faisant glisser la glissière centrale, repérez les trous dans les panneaux correspondant aux trous d'accès de la glissière centrale et fixez-les avec des vis.

Levier de déverrouillage, Glissière intérieure, Glissière centrale, Glissière extérieure, Fixez en utilisant les trous indiqués.

Français

Page 12, 13 & 19 - Vérifiez que le connecteur est correctement inséré et droit. Notez l'orientation du 15b sur (B & C). Reportez-vous à la page 11 pour les instructions d'installation de la diapositive.

Page 18 - Tournez dans le sens inverse des aiguilles d'une montre ou verrouillez en place. Surface supérieure, surface inférieure.

Page 23 - Assemblez la charnière en emboîtant les pièces ensemble, comme indiqué.

Page 24 - Mis de côté pour une étape ultérieure.

Page 26 - Avec l'aide d'un assistant, déplacez l'unité vers son emplacement final. À l'aide d'un niveau, dévissez les patins réglables là où c'est nécessaire pour mettre l'unité de niveau de côté à côté et d'avant en arrière

Page 27 - Avec le Stay étendu droit, insérez (15a) dans (15c) et tournez de 90 degrés pour le verrouiller en place. Après l'insertion, votre Stay devrait être dans cette position

Page 28 - Goupille d'arrêt de vis de réglage, goupille d'arrêt. Une fois que le support est entièrement installé. Avec le couvercle rabattable (O) complètement ouvert, ajustez la vis pour qu'elle touche la goupille d'arrêt et que le bras du support soit droit.

Page 30 - Surface finie

Page 32 - Installez les tiroirs en engageant les glissières intérieures (fixées aux côtés du tiroir) avec les glissières extérieures fixées au côté gauche, au côté droit et à la cloison. Poussez jusqu'à ce que le levier en plastique s'enclenche dans la glissière extérieure.

Page 34 - Fixez la porte avec des charnières comme indiqué.

Page 37 - Les fossettes du visage (9c) vers la porte.

Page 38 - Réglage de la porte et du dessus basculant. Pour ajuster le dessus basculant : Tournez la vis « A » pour régler de gauche à droite, et la vis « B » pour régler de haut en bas. Pour ajuster la charnière de la porte extérieure : Tournez la vis « A » pour régler de haut en bas, et la vis « B » pour régler de gauche à droite. Pour ajuster la charnière de la porte intérieure : Desserrez la vis « B » sur une ou LES deux sections et serrez une fois à l'emplacement approprié.

Page 39 - Les trous de charnière sont orientés vers l'avant de l'unité.

Page 41 - Étape 1 : Pliez le matelas et placez-le derrière le cadre du lit. Étape 2 : Repliez la section. Appuyez sur la broche pour déverrouiller, pliez les pieds jusqu'à ce qu'ils se verrouillent en place. Étape 3 Repliez la section. Appuyez sur la broche pour déverrouiller, pliez les pieds jusqu'à ce qu'ils se verrouillent en place. Étape 4 : Engagez le verrou aux deux extrémités.

Français

Page 42

CHARGES MAXIMALES

Ce meuble a été conçu pour supporter les charges maximales indiquées. En excédant ces limites de charge, le meuble pourrait devenir instable, s'effondrer, et/ou causer des blessures graves.

AVERTISSEMENT : Risque de blessure corporelle - ne pas placer une télévision sur ce meuble. Ce meuble n'est pas approuvé pour une utilisation avec une télévision.

Page 43

Enregistrez votre produit pour recevoir les éléments suivantes:

- * Détails sur les nouvelles tendances - un aperçu sur les nouveautés
- * Sondages - avoir une voix au sein de notre communauté
- * Offres exclusives et codes promo
- * Service de pièces de rechange rapide et facile

5 Étoiles

Visitez le site Web de votre détaillant local, évaluez votre produit acheté et laissez-nous quelques commentaires !