

WOODEN RAISED GARDEN BED

Assembly Instruction - Please keep properly for future reference.

If you find any missing boxes, damaged parts, or accessory shortages, please contact the customer service team of your purchasing channel immediately. We will resolve the issue as quickly as possible.

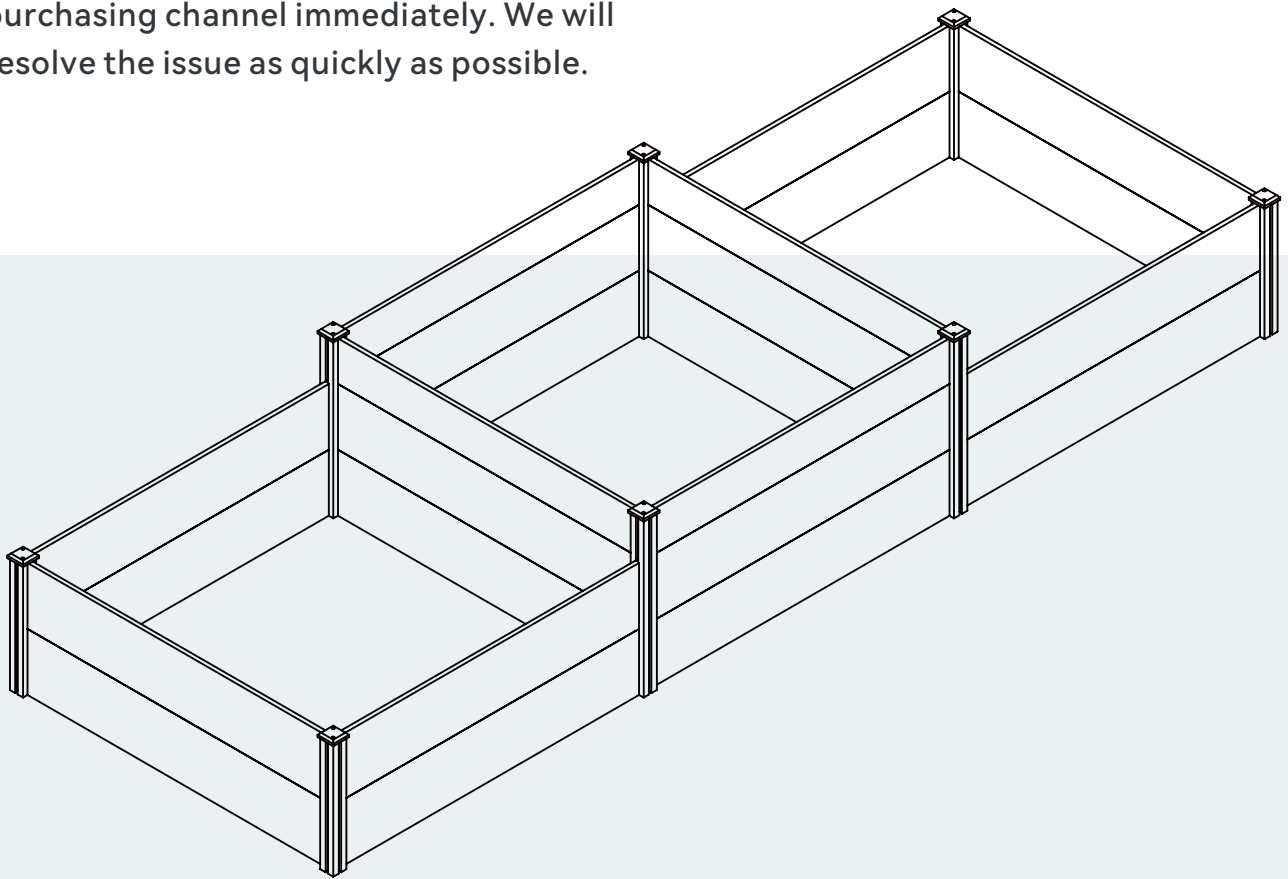

CONTACT US

11.84X4.07 FT

- **Email: service@grandtunnel.com**
In order to receive assistance more quickly, please provide

THE FOLLOWING INFORMATION:

- Order number
- Purchase platform
- Purchase date
- Detailed description of the issue along with photos (if applicable)

Important – Please read these instructions carefully before starting the installation.

EN

CUSTOMER SERVICE GUIDE

Thank you for choosing our product! We are committed to providing you with excellent service. If you find any missing parts, damaged packaging, or product damage after receiving all packages, please follow the steps below to quickly contact our customer service team. We will do our best to resolve your issue.

1. Missing Parts

Verify Parts:

1. Refer to the “Parts List” in the manual to verify the name, specifications, and quantity of the missing parts.
2. Take a clear photo of the parts list and mark the missing parts with detailed information, e.g., “Missing 5 pieces of M6X30mm screws.”

Contact Us:

· By Email:

Send an email to service@grandtunnel.com, with the subject line “Missing Parts Issue.” Include the following in the email:

- A description of the missing parts and a photo of the parts list.
- Order details (order number, purchase platform, purchase date).

2. Product or Packaging Damage

If it affects normal use:

Steps:

1. Take clear photos or videos showing the damaged parts and the extent of the damage (multiangleshots are recommended).
2. Email the photos/videos along with order details to service@grandtunnel.com, with the subject line “Product Damage Issue.”

Resolution:

After verification, we will arrange for a replacement part, product exchange, or refund as quickly as possible.

If it does not affect normal use:

Steps:

1. Contact our customer service team (by email: service@grandtunnel.com).
2. Provide a description of the damage and include relevant photos or videos.

Resolution:

We will provide repair guidance or an appropriate compensation plan based on the specific situation.

Contact Us:

· Customer Service Email: service@grandtunnel.com

Helpful Tips

To process your issue efficiently, please prepare the following information:

- Order details (order number, purchase platform, purchase date).
- Clear photos or videos.
- We are committed to providing quick and professional solutions, no matter the size of the issue, to ensure your satisfaction.

Thank you for your trust and support! We hope you enjoy using our product!

! NOTICE

Please retain instructions for future needs.

- Do not stand on or use any parts of this item as a step ladder.
- Fasten screws loosely during assembly. Do not firmly tighten the screws until the item is completely assembled.
- Double-check all the bolts, screws, and knobs have been firmly tightened before use.
- To prevent items fall apart, please regularly check if all bolts, screws, and knobs are secure.
- Do not use or store this item in the proximity of open flame or flammable/combustible chemicals.
- Be aware that some parts are heavy and have sharp edges when assembling and using.
- If any parts are missing, broken, damaged, or worn in 90 days, stop using or assembling this product, please do not hesitate to contact us, we will send the factory replacement parts for free.
- Do not use this item in a way inconsistent with the manufacturer's instructions as this could void the product warranty.
- This item is made of wood and may expand due to moisture.

TOOLS REQUIRED

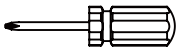

PHILLIPS
SCREWDRIVER

1 PERSON
ASSEMBLY

APPROXIMATELY
60 MIN.
ASSEMBLY

HARDWARE

A

M4x35mm
x16

B

x28

PARTS

1

x16

2

x4

3

x4

4

x4

5

x4

6

x8

PRODUCT ASSEMBLY

1

Install components (1) and (1) sequentially into the slots of components (5) and (5). Use wooden dowels (B) to secure components (1) and (1) into the pilot holes in the middle.

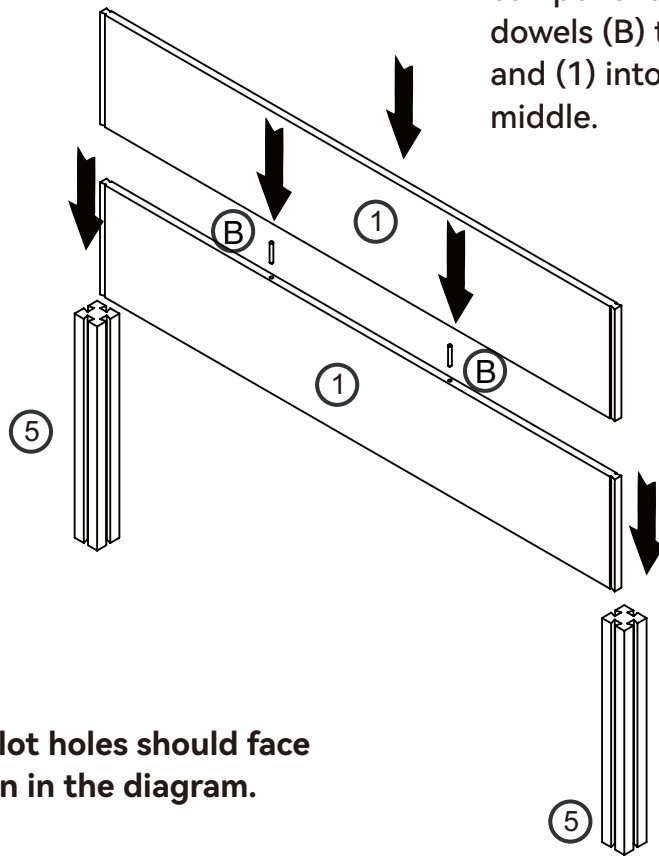

Note:
The side with pilot holes should face inward, as shown in the diagram.

2

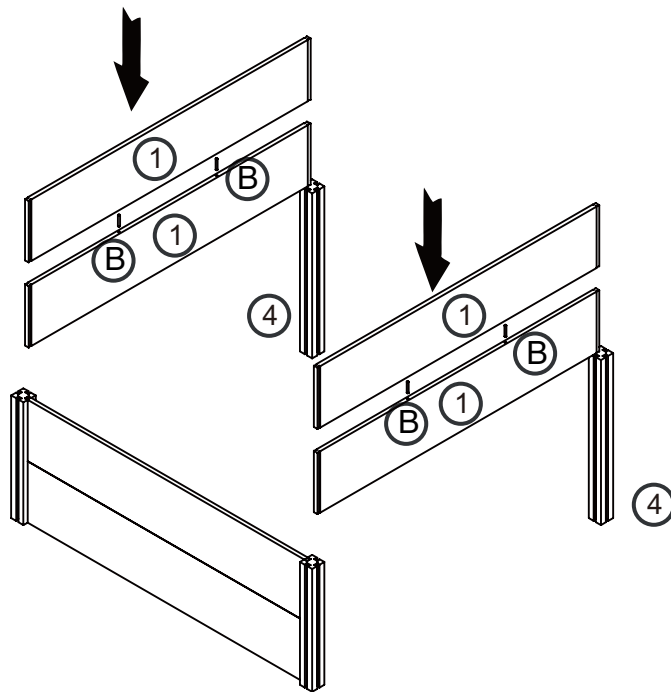

Install components (1) and (1) sequentially into the slots of components (5) and (4). Use wooden dowels (B) to secure components (1) and (1) into the pilot holes in the middle, as shown in the diagram.

3

Install components (1), (2), and (3) sequentially into the slots of components (4) and (4), as shown in the diagram. Use wooden dowels (B) to secure components (1), (2), and (3) into the pilot holes in the middle.

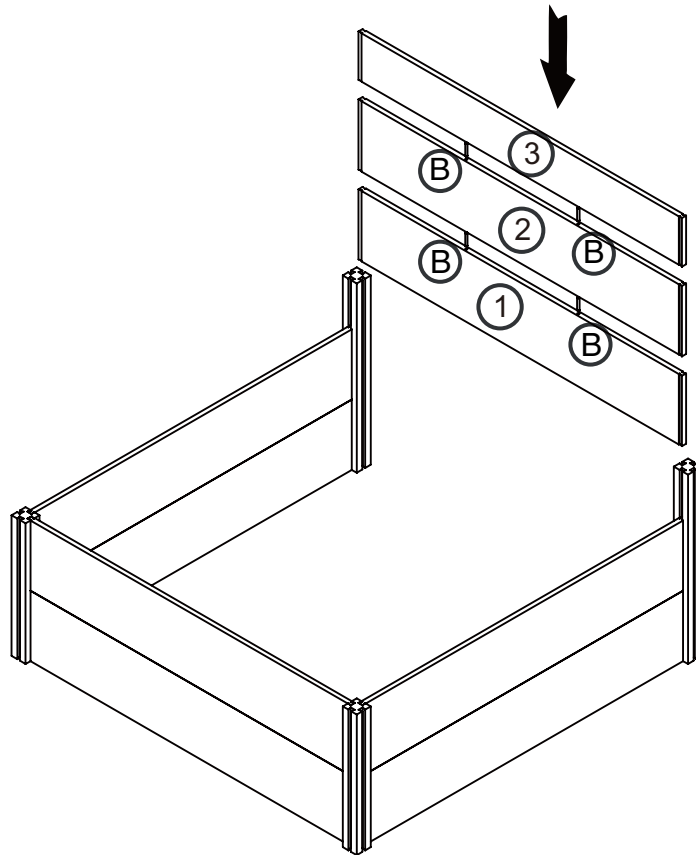

PRODUCT ASSEMBLY

4

Install components (1), (2), and (3) sequentially into the slots of components (4) and (4), as shown in the diagram. Use wooden dowels (B) to secure components (1), (2), and (3) into the pilot holes in the middle.

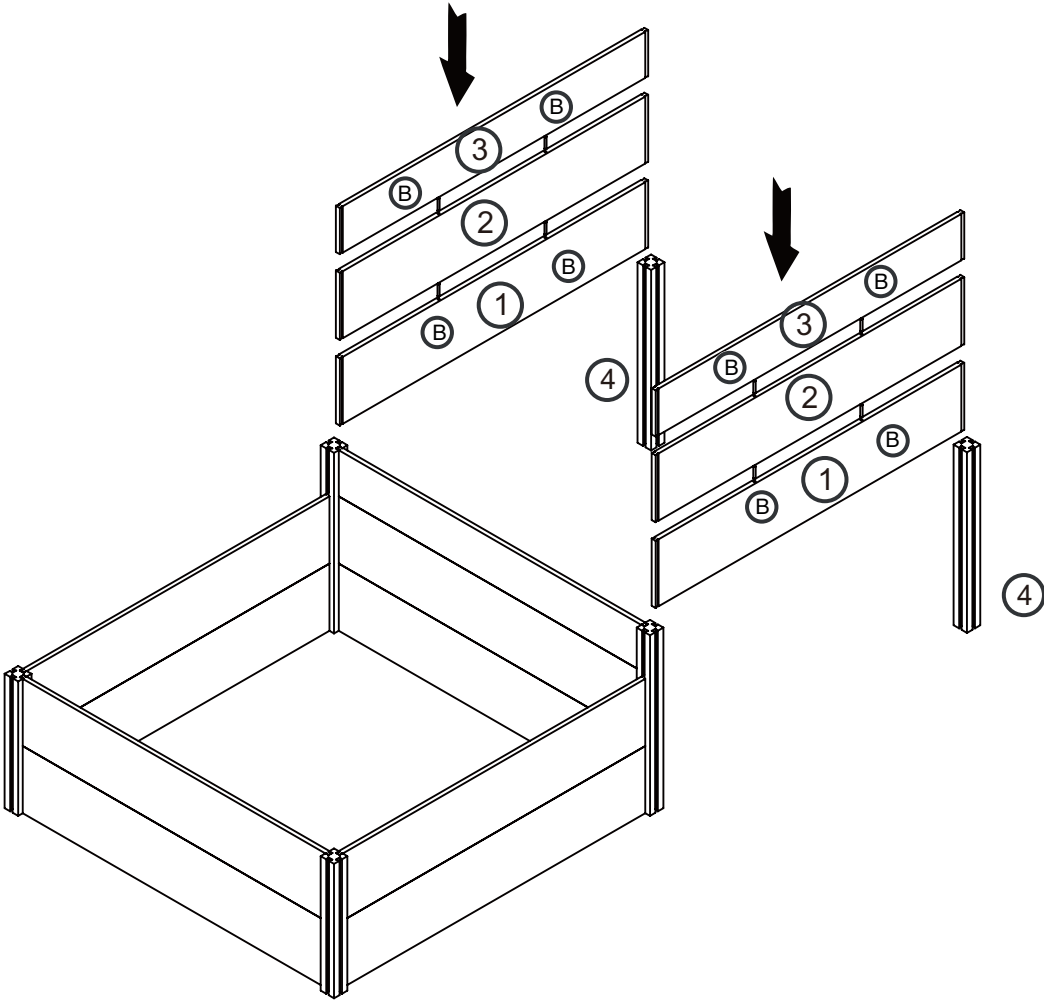

PRODUCT ASSEMBLY

5

Install components (1), (2), and (3) sequentially into the slots of components (4) and (4), as shown in the diagram. Use wooden dowels (B) to secure components (1), (2), and (3) into the pilot holes in the middle.

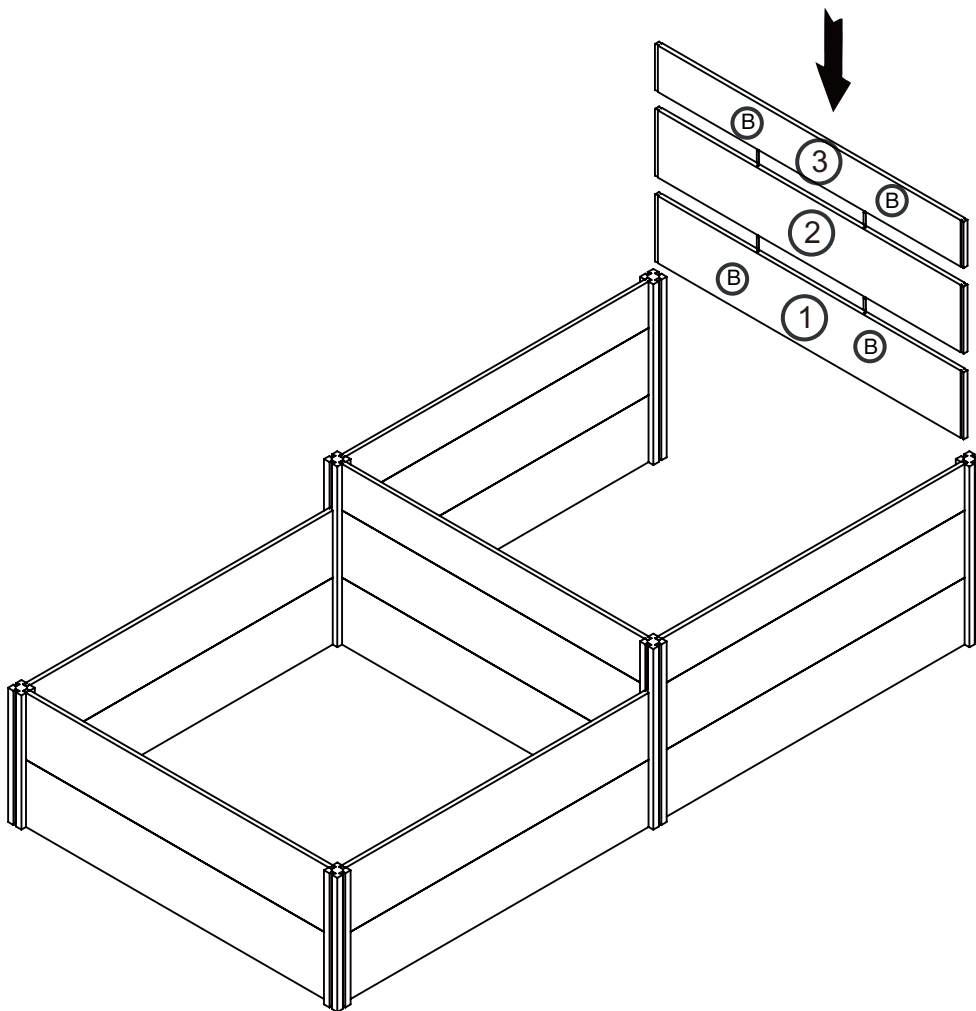

PRODUCT ASSEMBLY

6

Install components (1) and (1) sequentially into the slots of components (4) and (5). Use wooden dowels (B) to secure components (1) and (1) into the pilot holes in the middle, as shown in the diagram.

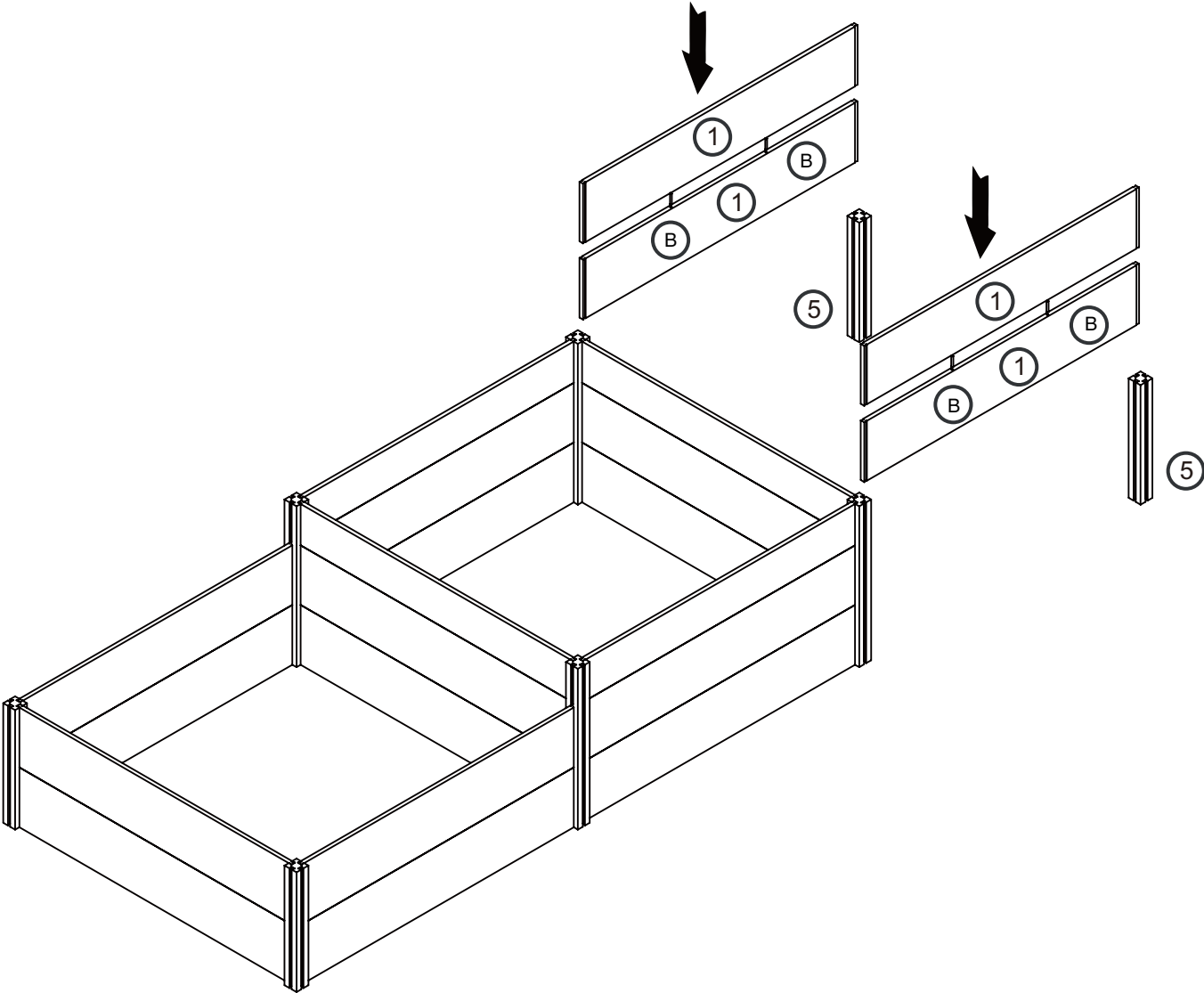

PRODUCT ASSEMBLY

7

Install components (1) and (1) sequentially into the slots of components (5) and (5). Use wooden dowels (B) to secure components (1) and (1) into the pilot holes in the middle, as shown in the diagram.

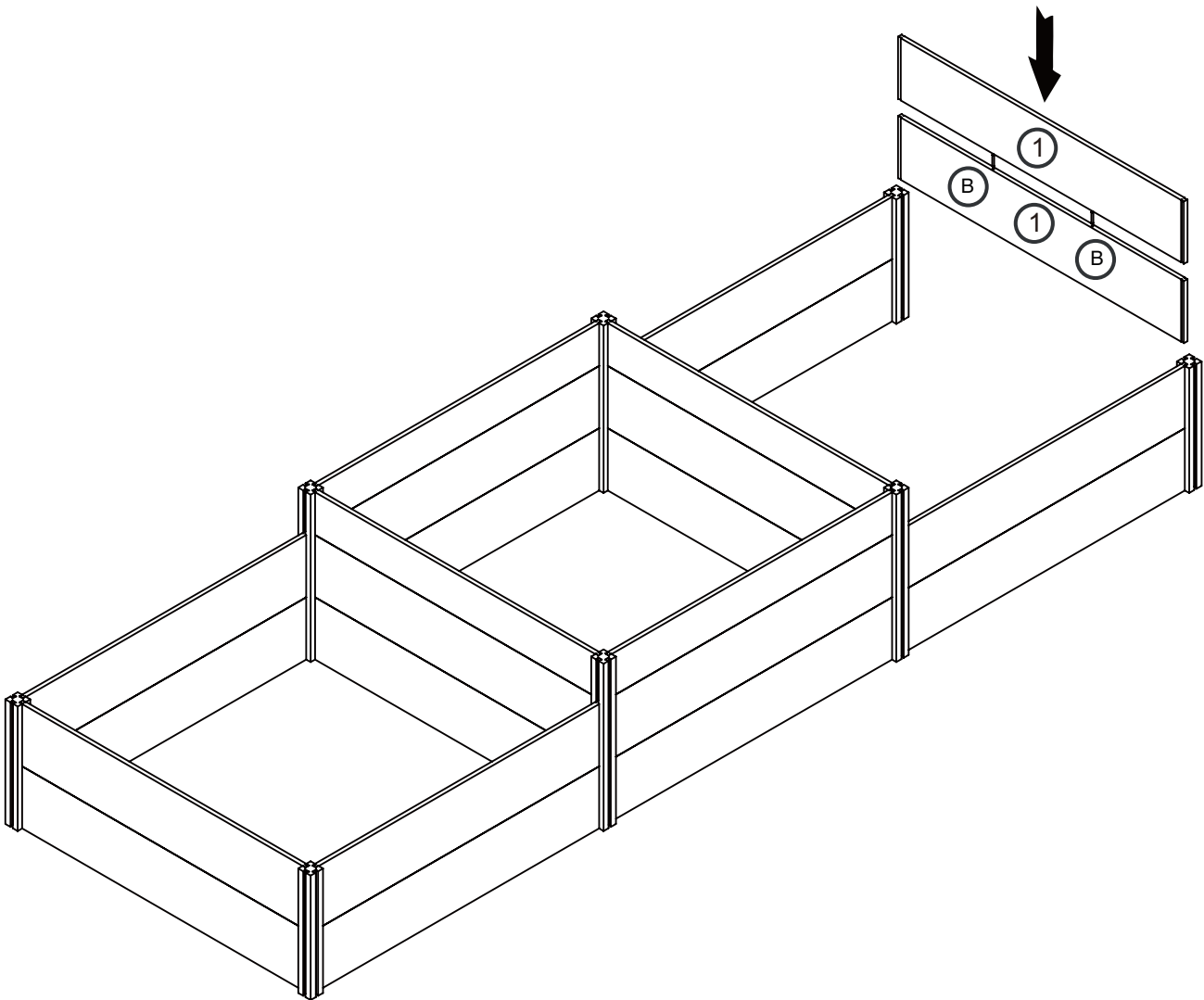

PRODUCT ASSEMBLY

8

Use screws (A) to fix component (6) onto the top ends of components (5) and (4), as shown in the diagram.

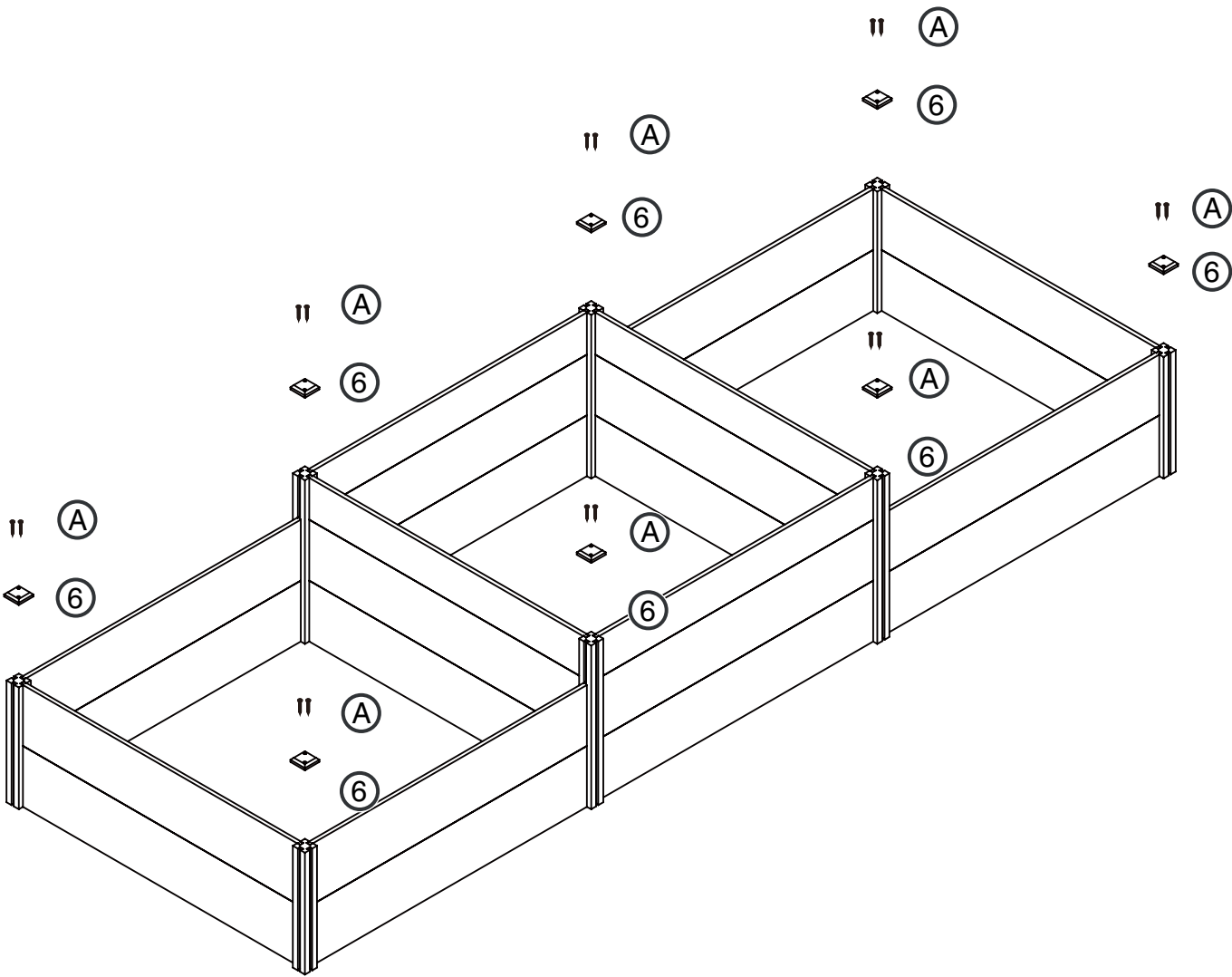

PRODUCT ASSEMBLY

9

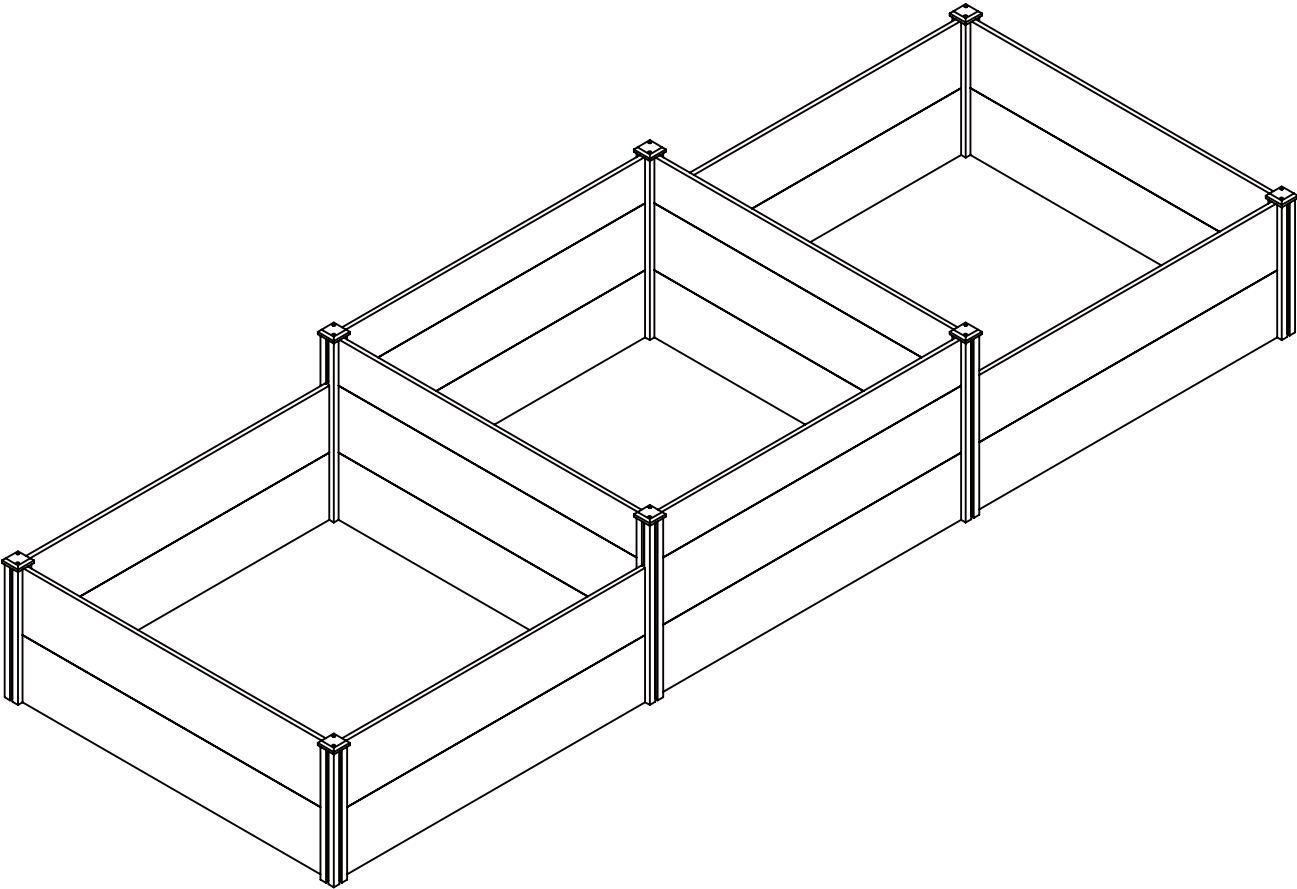

Installation Completed

| WOODEN RAISED GARDEN BED

SKU:
BF21A1-1A1A0

V1.0