











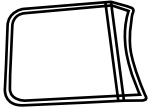

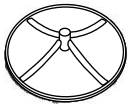
# 3PCS WICKER SWIVEL CONVEERSATION SET

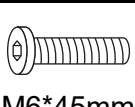
## -SWIVEL CHAIR

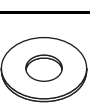
### Parts List:

NO.	part	Diagram	Qty pcs
A1	Left Arm		1
A2	Right Arm		1
B	Chair Back		1
C	Seat Panel		1
D	Chair Base		1
E	U-Shape Fitting		1
F	Bolts M6*45mm		4
G	Bolts M6*35mm		8
H	Nuts		4
I	Washers		12
J	Seat Cushion		1
K	Back Cushion		1
L	Wrench		1
M	Open Wrench		1

\* Don't fully tighten all the bolts till the very end!

### PRE-ASSEMBLY PREPARATION:

- Please read through the instructions before beginning assembly.
- Clear out the space for assembly and lay out all of the parts based on the Parts List, extra room will allow you to easily determine if all the pieces are present.
- Keep small parts and pieces away from children until fully assembled.

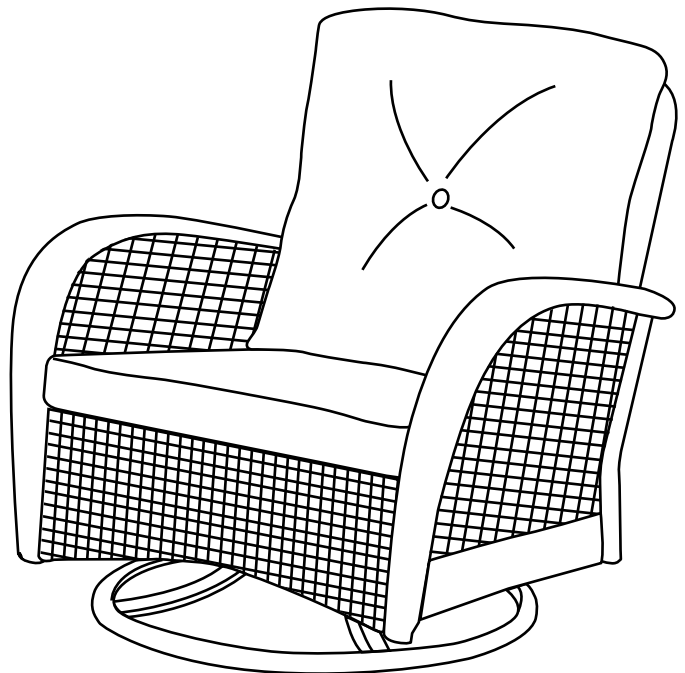

Step 1

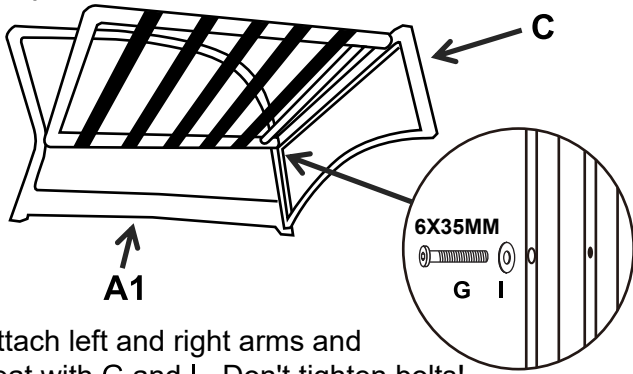

Attach left and right arms and seat with G and I. Don't tighten bolts!

Step 2

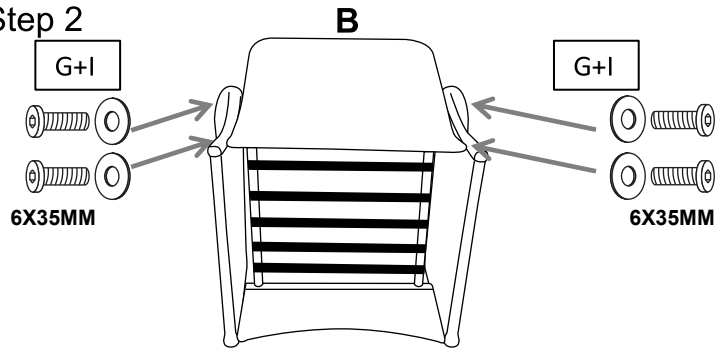

Attach left and right arms and back with G and I. Don't tighten bolts!

Step 3

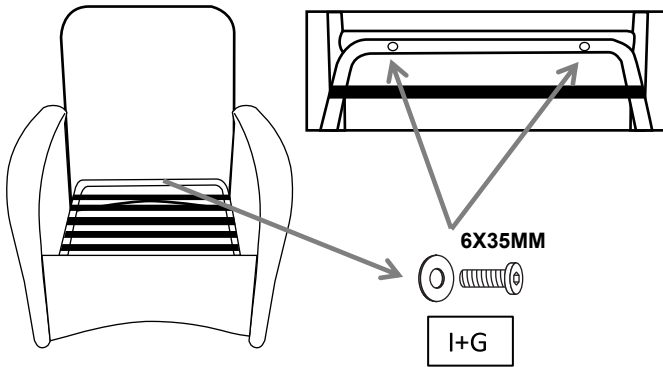

Attach seat and back panel with G and I. Tighten all the bolts (G) with wrench (L).

Step 4

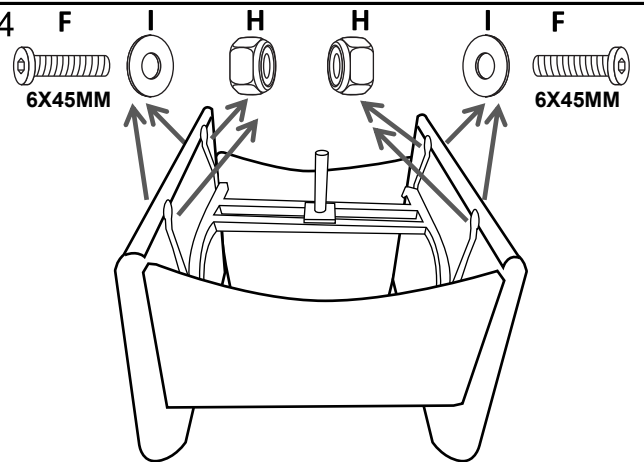

Attach U-Shape Fitting, left and right arms with F, H and I. Tighten all the bolts (F) and nuts (H) with M and L.

Step 5

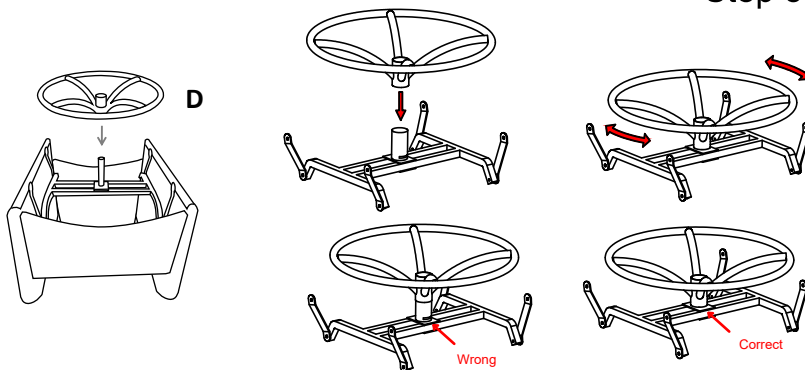

Insert chair base (D) into chair bracket (E), then rotate chair base (D) back and forth until it is fully inserted

Step 6

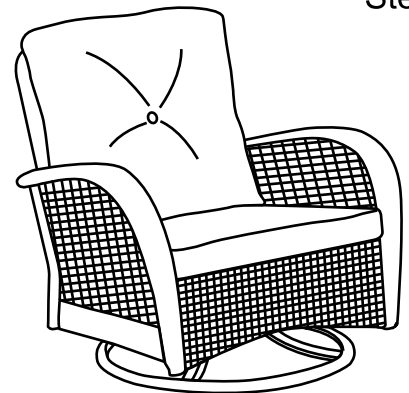

Put the seat cushion (J) and the back cushion (K) on the chair.

The chair is full assembled now.

# Assembly Instructions

## Parts List (END TABLE):

NO.	part	Diagram	Qty pcs
A	Table Top		1
B	Table Leg		4
C	Table Shelf		1
D	Screws		12
E	Washers		12
F	Hex Wrench		1

