

# Assembly Instructions

**CAUTION:** You must read this Assembly Instructions before you proceed.

Please look in the **Table Top** for hardware packs.

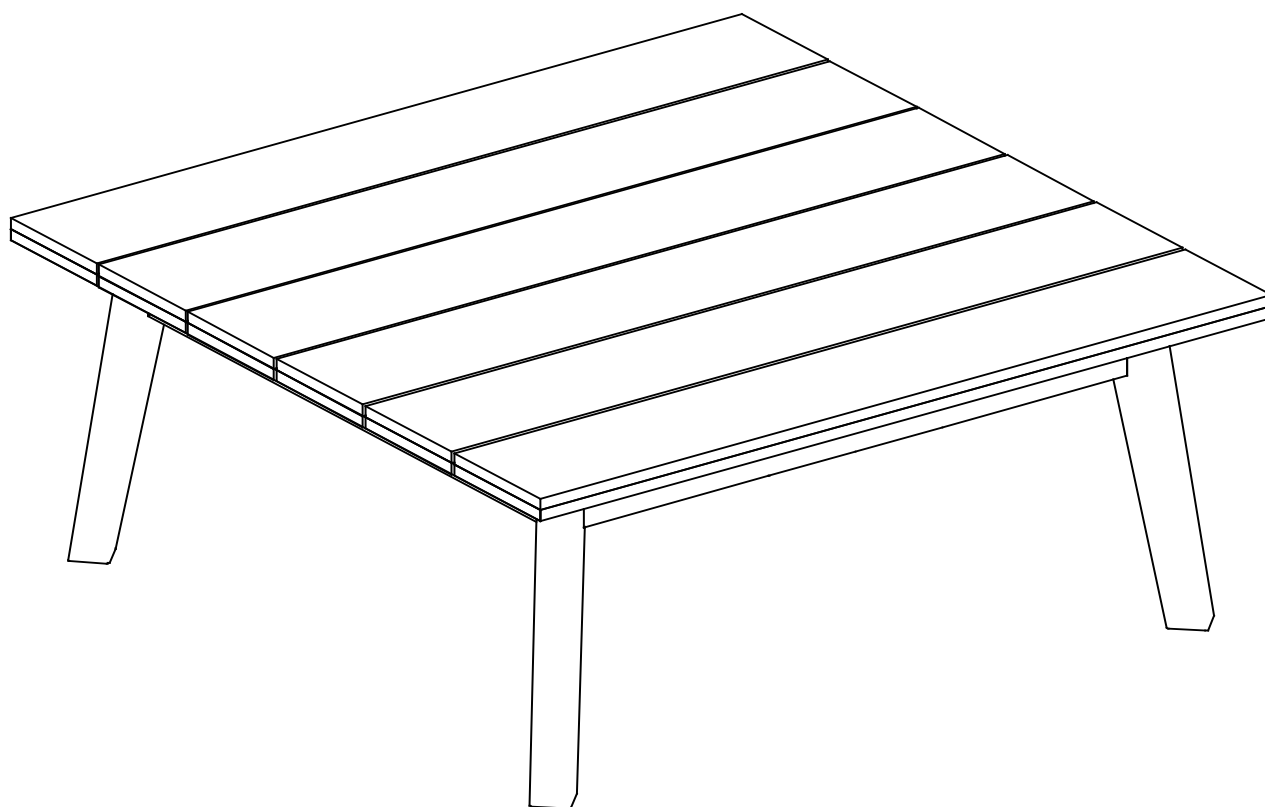

## Table



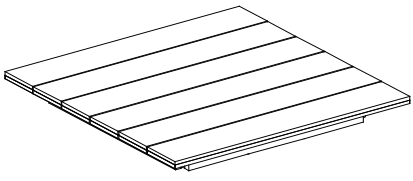

**CAUTION :** This Table is NOT a TOY.

Keep your child / children at bay in the process of assembly.  
For turning the Table and to prevent damage to the Table, 02 people may be needed to execute this action.

## Part List

Label	Picture	Description	QTY
A	 A perspective drawing of a rectangular table top made of several parallel wooden planks.	Table Top	1
B	 A perspective drawing of a single, tapered wooden leg.	Legs	4





## Hardware

Label	Picture	Description	QTY
①	 A perspective drawing of a bolt with a hexagonal head and a threaded shaft.	Bolt (M6x50mm)	9
②	 A perspective drawing of a flat, circular washer with a central hole.	Washer (M6.5/20x2mm)	9
③	 A perspective drawing of an L-shaped Allen wrench.	Allen Wrench	1

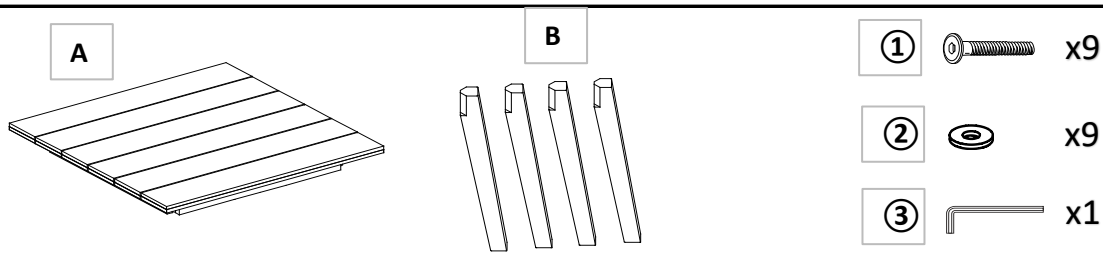
# Assembly Preparation

## Before Beginning Assembly:



-  • Read instructions, cover to cover-
-  • Have 2 adults on hand for assembly-
-  • Do not assemble on flooring or carpet-
-  • Assemble on a clean non-marring surface (packing foam)-
-  • Save all packaging until finished-

# Assembly Steps

## Overview

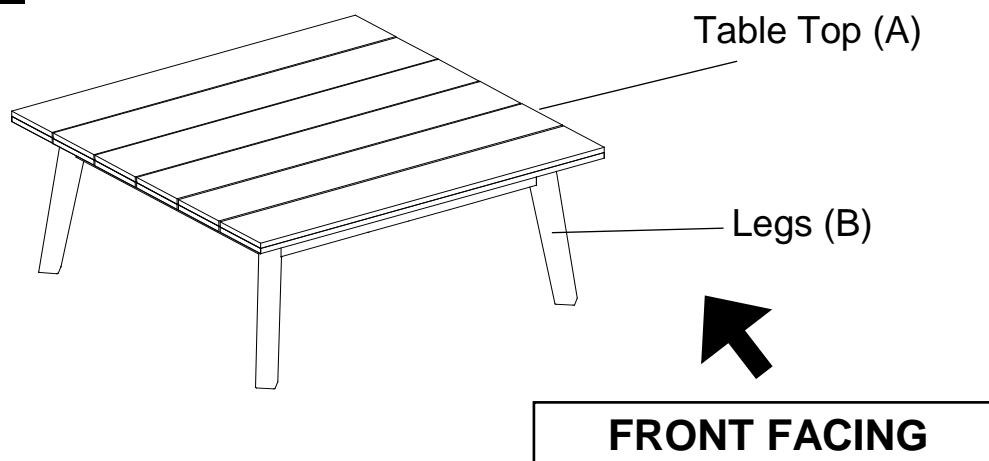

This Table has multiple parts and may require up to 30 minutes to assemble. To give you an overview of the Table parts, the above picture is to help you put the various parts into perspective. Please read through the instructions herebelow to familiarise yourself with the parts and steps before assembly.

## Step 1

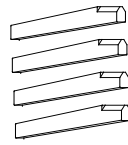
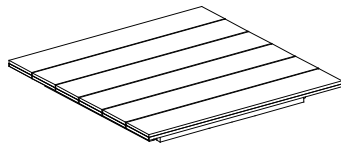

Unpack and place all parts on a clean, non-marring surface.

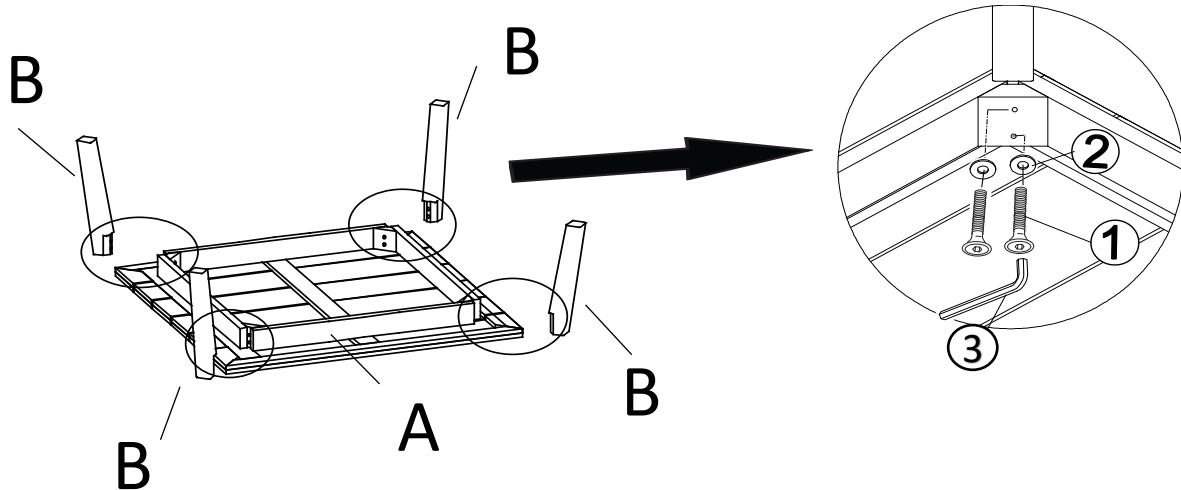

Turn the Table Top (A) (bottom-side up) and place it on a clean, soft surface to avoid any scratches or damage to the product.

Loosely affix one of the Legs (B) into one of the mounting positions at the corners of the Table Top (A), then secure it using the Bolts (1), Washers (2) and Allen Wrench (3), as shown above.

**Repeat the same process with the remaining Legs (B).**

**CAUTION: When tightening these Bolts, tighten sequentially.**

**DO NOT tighten any bolt fully and then move towards the next one.**

**This would cause the frame to warp.**

**WARNING!! IF THE TABLE IS NOT STABLE, IT COULD LEAD TO DAMAGING THE PRODUCT.**

## Step 3

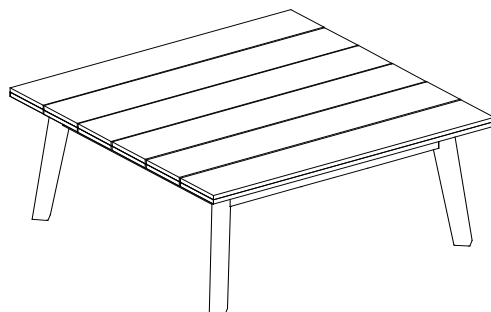









Turn the Table right side up

Ensure all bolts are fully locked into position.

**Your Table is ready to be used.**

**Caution: This Table can only be used on a flat, level surface.**

## Care & Maintenance

-  ● Do not put hot items directly on furniture surface
  -  ● Do not clean furniture with harsh cleansers or polish.
  -  ● To obtain the longest lifespan of your outdoor products, minimizing exposure to direct sunlight is recommended.
  -  ● Children should not climb or jump on the furniture.
  -  ● Do not write on furniture without a padded barrier to protect the surface.
  -  ● To obtain the longest lifespan of your outdoor products, avoid extended and lengthy exposure to rain, snow, and direct sunshine. Whenever possible cover the product and /or place under patio or awnings.
  -  ● Not for commercial use. For residential use only .
  -  ● Stains may be removed with mild soap solution and damp cloth.
- 
-  ● Dust and pick-up spills using a clean, non-colored, lint-free cloth .