

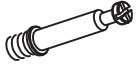









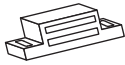

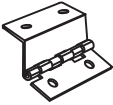
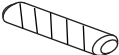
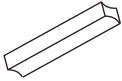

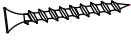
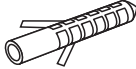
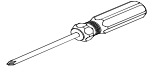
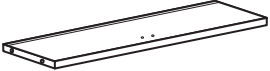
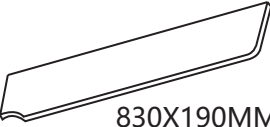
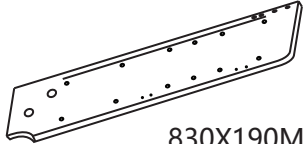

NO.	PARTS LIST	QTY (pcs)	NO.	PARTS LIST	QTY (pcs)
①	 M6X35MM	12 pcs	②	 M6X35MM	12 pcs
③		1 pcs	④		2 pcs
⑤		4 pcs	⑥	 M6X30MM	8 pcs
⑦		2 pcs	⑧	 M4X16MM	4 pcs
⑨	 M5X20MM	4 pcs	⑩	 M3X12MM	20 pcs
⑪	 M4X35MM	2 pcs	⑫	 M6x30MM	2 pcs
⑬		1 pcs			

NO.	PARTS LIST	QTY (pcs)	NO.	PARTS LIST	QTY (pcs)
Ⓐ	 525X190MM	1 pc	Ⓑ	 830X190MM	1 pc
Ⓒ	 830X190MM	1 pc	Ⓓ	 523X160MM	1 pc
Ⓔ	 525X190MM	1 pc	Ⓕ	 525X190MM	1 pc
Ⓖ	 375X260MM	1 pc	Ⓗ	 375X260MM	1 pc
Ⓘ	 387X267MM	2 pc	Ⓙ	 542MM	2 pc
Ⓚ	 525X40MM	1 pc	Ⓛ	 375MM	1 pc
Ⓜ	 537X190MM	1 pc	Ⓝ	 525X50MM	1 pc
Ⓞ		1 pc			

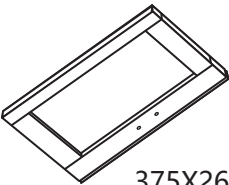
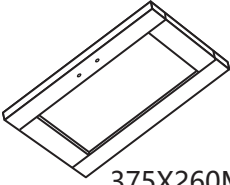
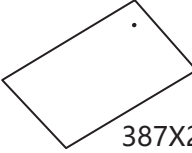
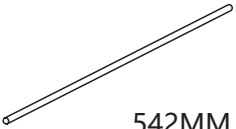

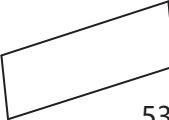
⚠ CAUTION

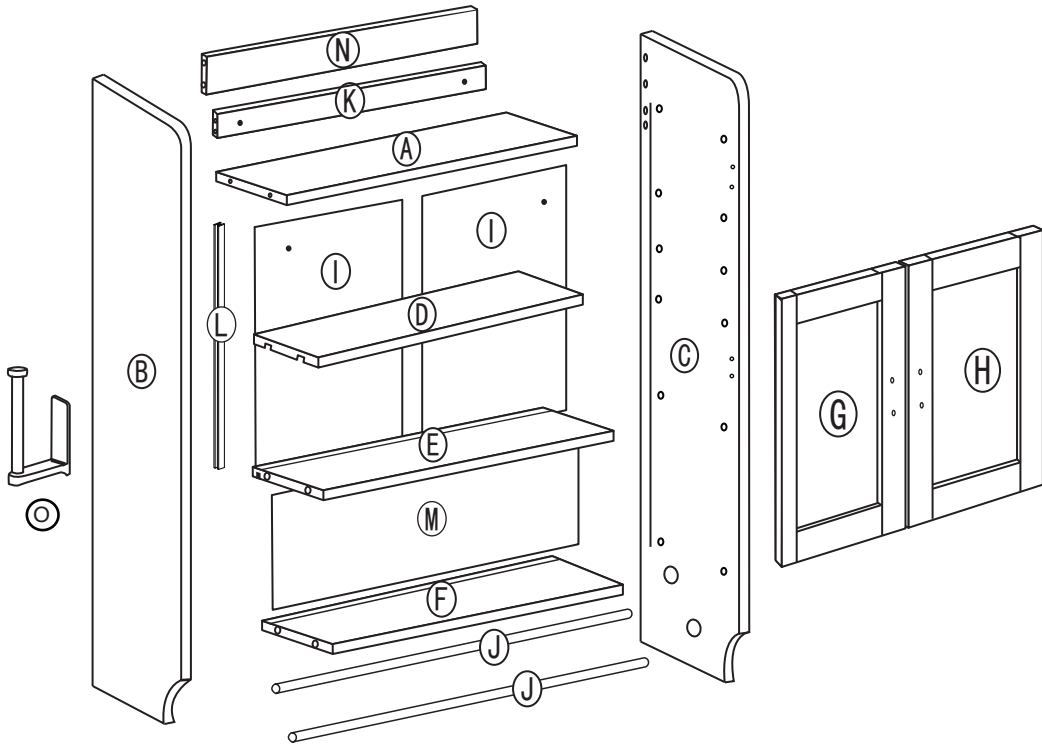
1. Read each step carefully before starting.
2. It is important that each step is performed in correct order to avoid difficulties.
3. Identify, sort and count the parts before assembly.
4. Assemble your furniture on packaging cardboard to prevent scratch or damage.
5. Clean the product with mild cleanser using soft damped cloth. Do not use harsh or abrasive cleanser.
6. Using incompatible hardware might cause damage to product.

"1" Hardware
Assembly example

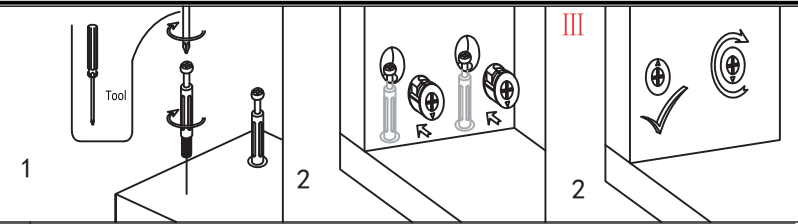

STEP 1

⑦ X 2

⑧ X 4

④ X 2

⑤ X 4

⑩ X 10

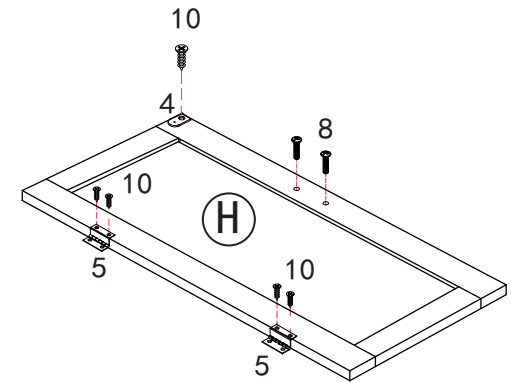
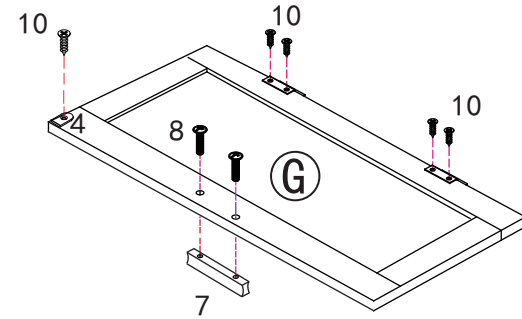
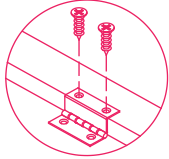

STEP 2



③X1



⑩X2

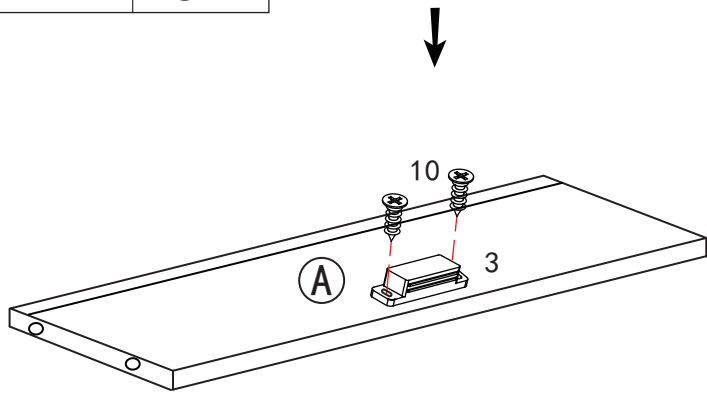
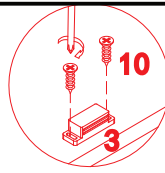

STEP 3



①X12

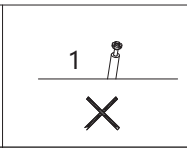
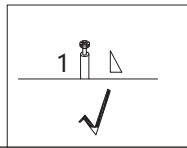
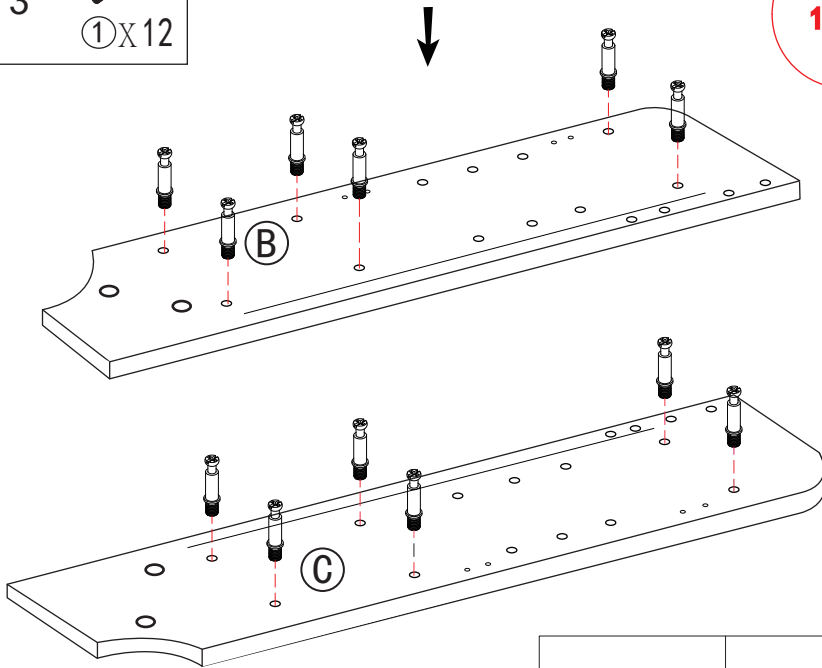
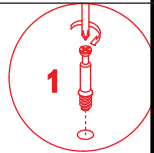

STEP 4



②X2



⑥X4

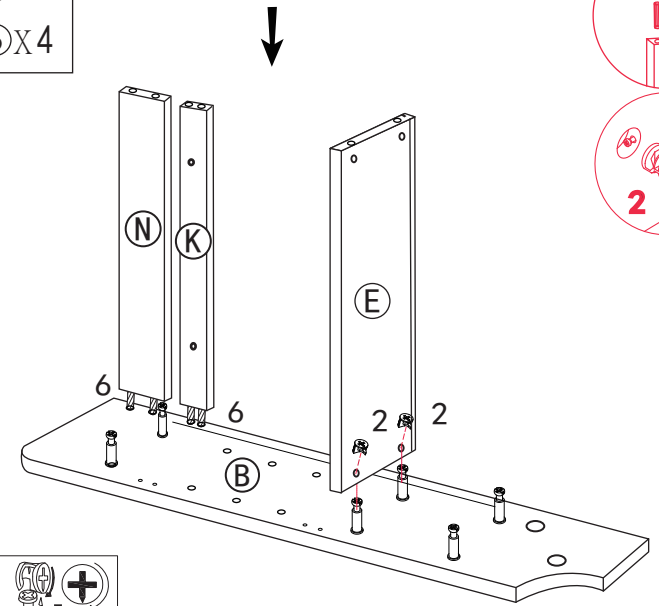
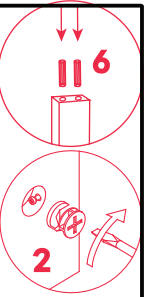

2 ✓

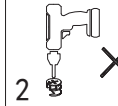

2 ✗

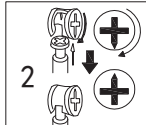

2 +

STEP 5



②X4

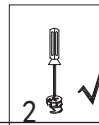
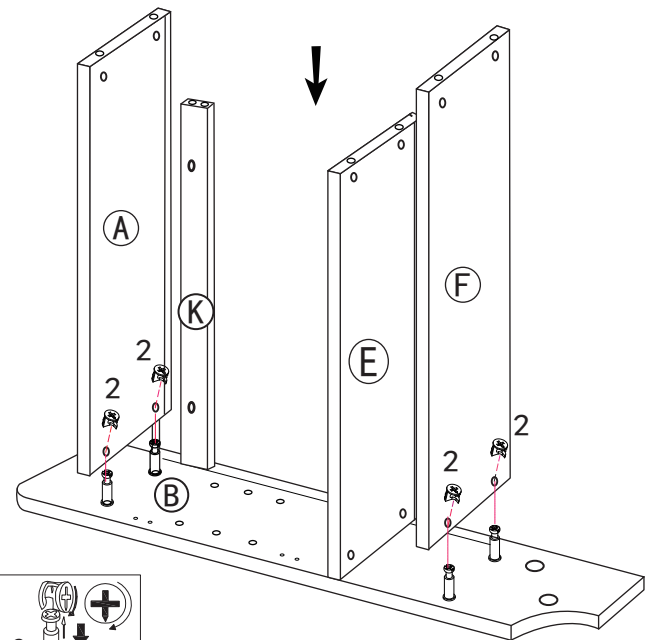

2 ✓

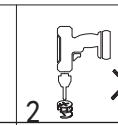

2 ✗

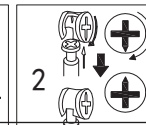

2 +

STEP 6

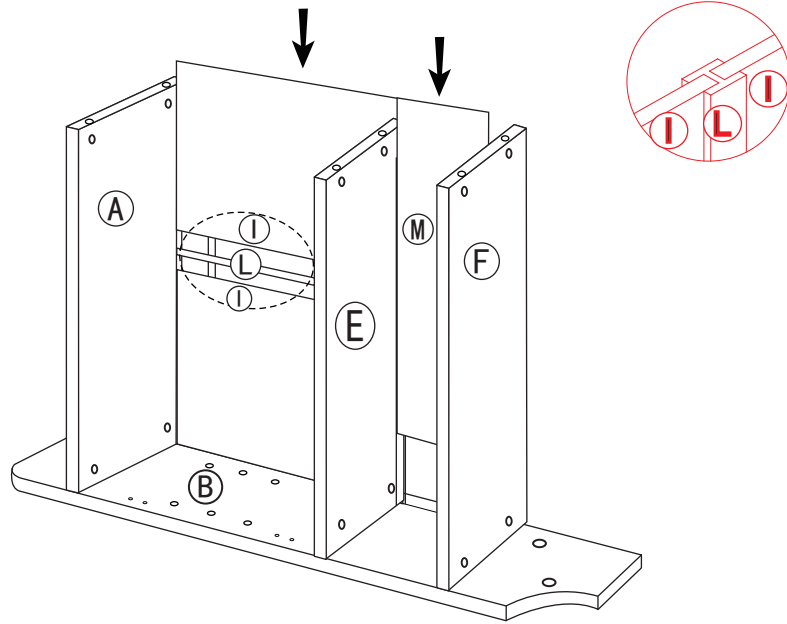

STEP 7

②X6
⑥X4

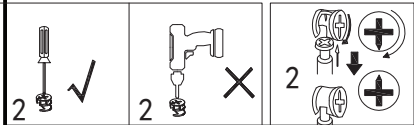
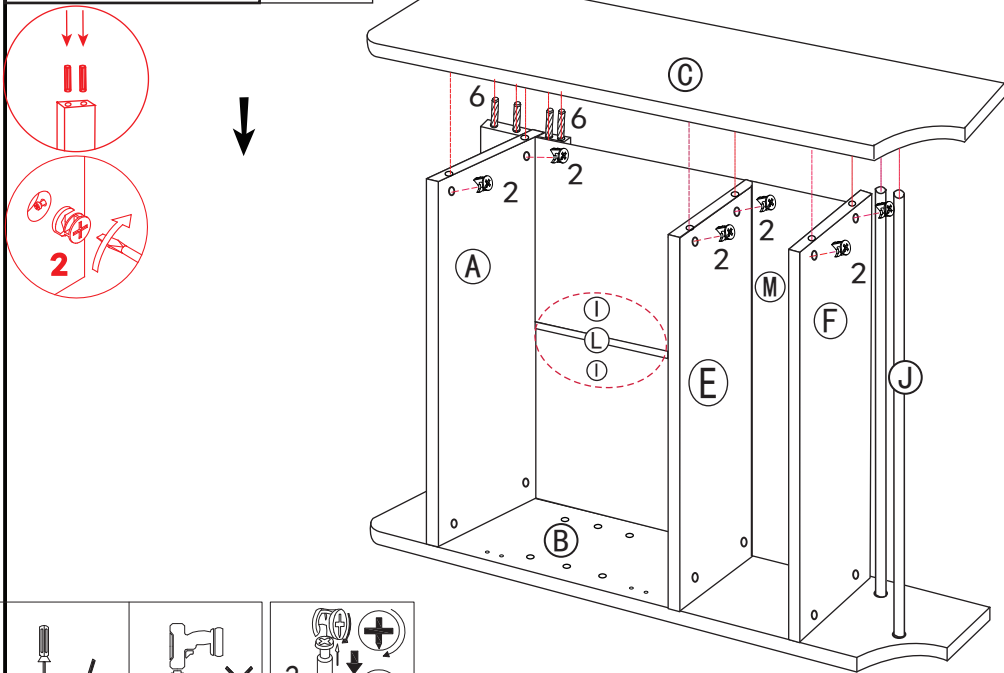

STEP 8

⑩X8

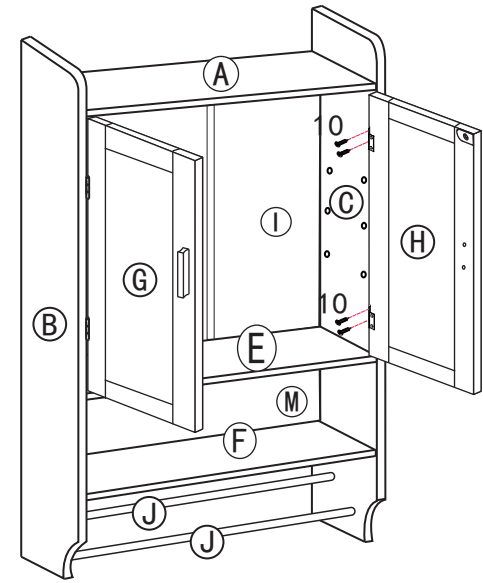

STEP 9

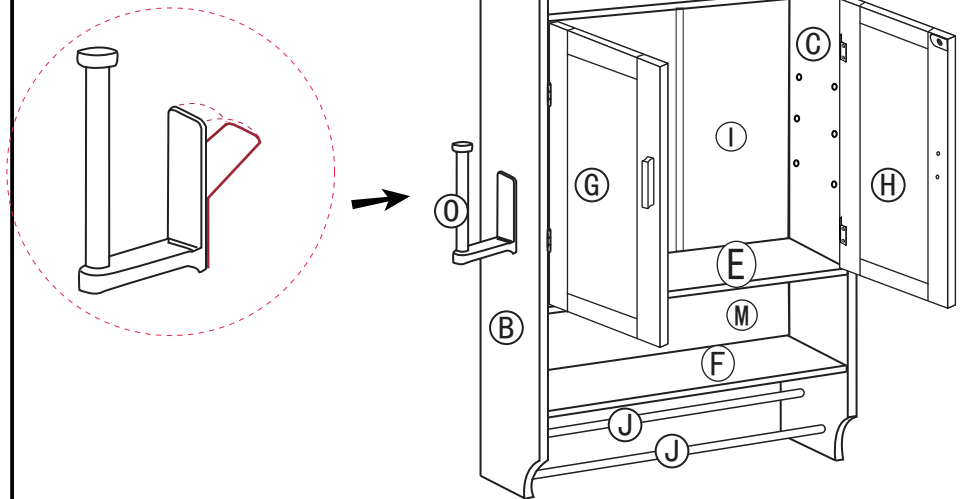

STEP 10

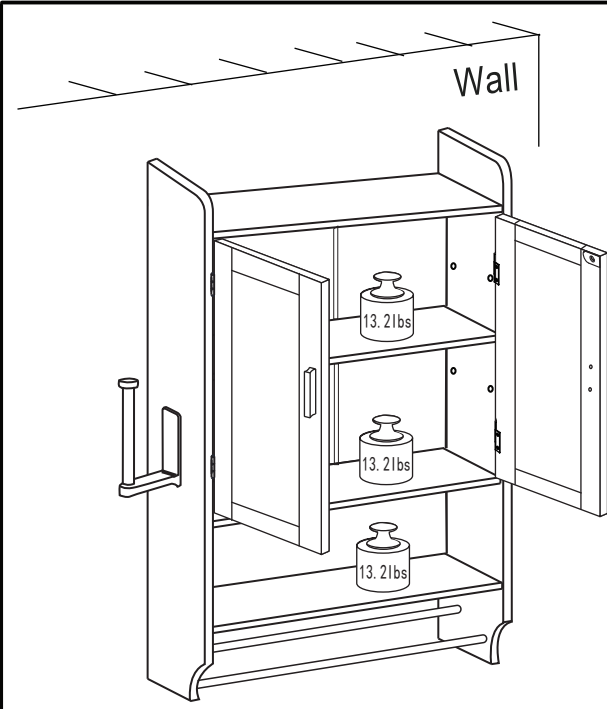
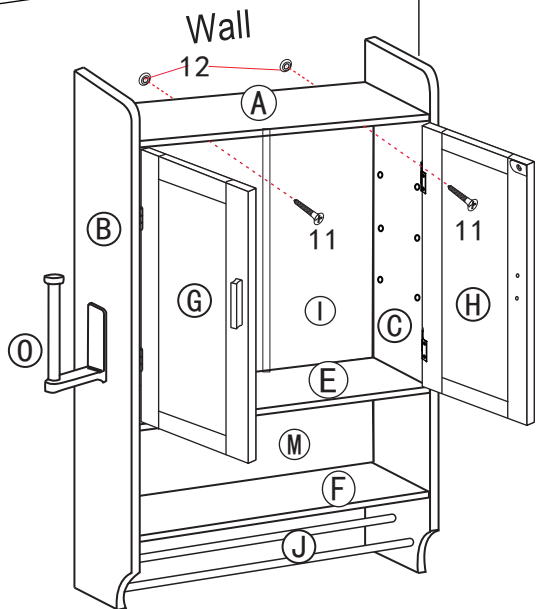
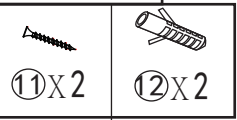

Warning
 --This product can only bear the weight within the maximum static load capacity; bearing capacity may result in product loosening or even serious damage.
 --R & D avoids accidents, injuries or death caused by children climbing or jumping on furniture.

STEP 11

