

Nesting Rectangle Coffee Tables

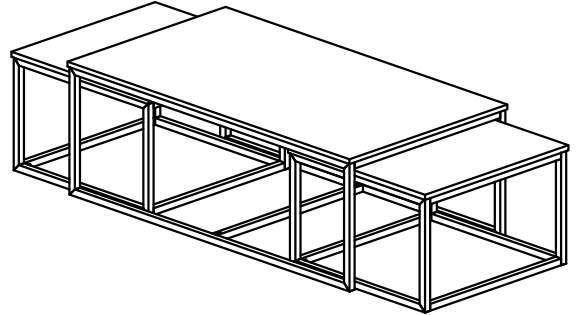
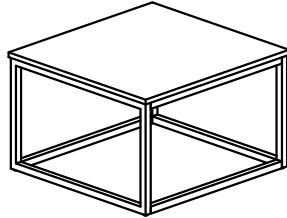
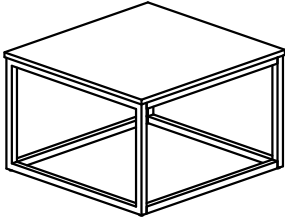

Note: Illustration shown with optional Nesting Tables underneath.

Thank you for purchasing the Nesting Rectangle Coffee Tables. We have found it helpful to have a second person present during the assembly process.

Nesting Rectangle Coffee Tables Assembly Instructions

Parts

NO.	DRAWING	DESCRIPTION	QTY
A		TABLE TOP	2
B		SIDE FRAME	4
C		STRETCHER TOP	4
D		STRETCHER BASE	4

NO.	DRAWING	DESCRIPTION	QTY
E		M6x40MM BOLT	24
F		M6x20MM BOLT	16
G		FLAT WASHER	40
H		ALLEN KEY	1

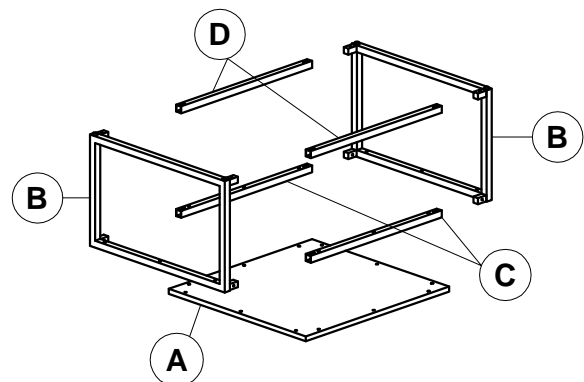

Step 1

Read through these instructions thoroughly before beginning assembly. We have found this to be of great value when assembling this product.

Step 2

Remove all parts and hardware from packing material. Wooden pieces should be placed on a non abrasive surface to prevent damage to the finish

Step 3

Attach leg stretchers (C&D) to Side Frame Assembly (B) using 8-M6x20MM Hex Bolts (F) and Flat Washer (G). NOTE: DO NOT TIGHTEN FIRMLY AT THIS TIME!

Note: Repeat this step for 2 Frames Assemblies.

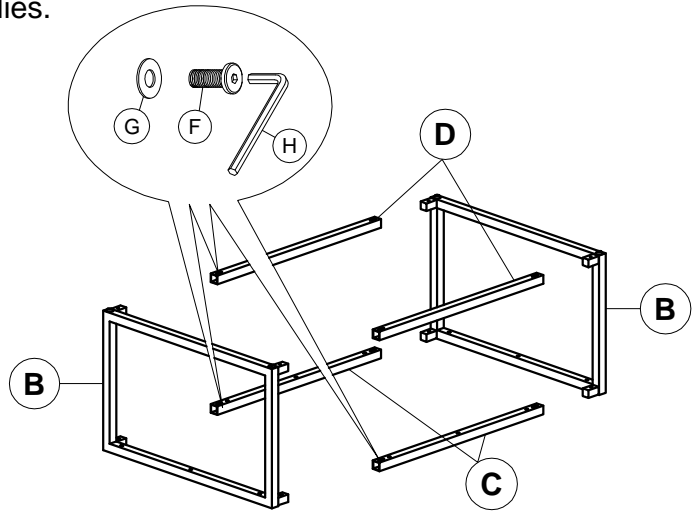

Step 4

Lay Table Top Assembly (A) upside down on a non abrasive surface. Attach Leg-Frame using 12-M6x40MM Hex Bolts (E) and Flat Washer (F). NOTE: TIGHTEN ALL BOLTS AT THIS TIME!

Note: Repeat this step for 2 Nesting Rectangle tables.

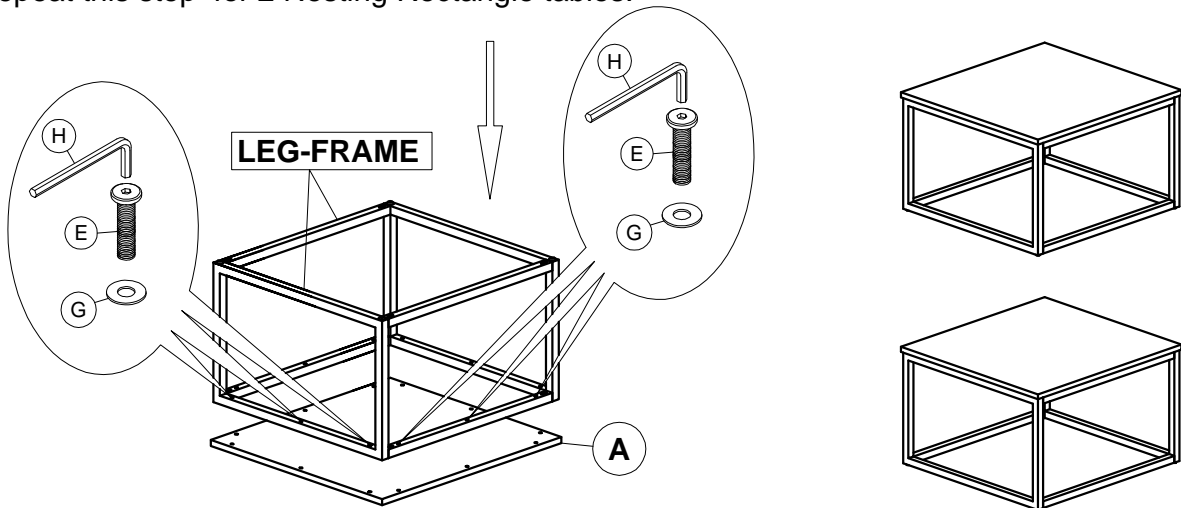

CARE

Clean with a non abrasive cloth using a mild soap. Make sure to wipe dry.
