

6-Drawer Dresser

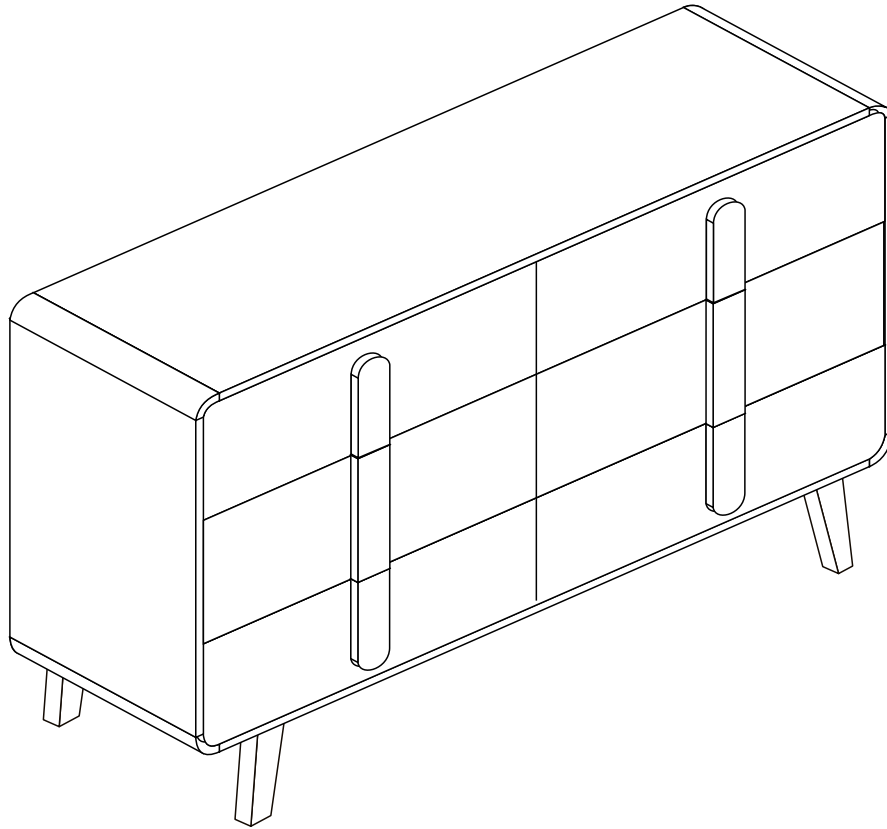

Please make sure to read the instruction manual carefully before installing the product.

Do Not Return This Product!

Contact our customer service team
for help first.

WARNING

- Unit can tip over causing severe injury or death.
- Anchor unit to stud in wall (if instructed to)
- Do Not allow children to climb on unit.
- put heavy items on lower shelves or drawers.

**PEOPLE NEEDED
FOR ASSEMBLY: 2**

CONTACT US!

Do NOT return this product!

Contact our friendly customer service team first for help.

- Open your item in the area you plan to keep it to avoid excessive heavy lifting.
- Identify, sort and count the parts before attempting assembly.
- Back panel must be used to make sure your unit is sturdy.
- Do NOT use harsh chemicals or abrasive cleaners on this item.
- Never push,pull,or drag your furniture.







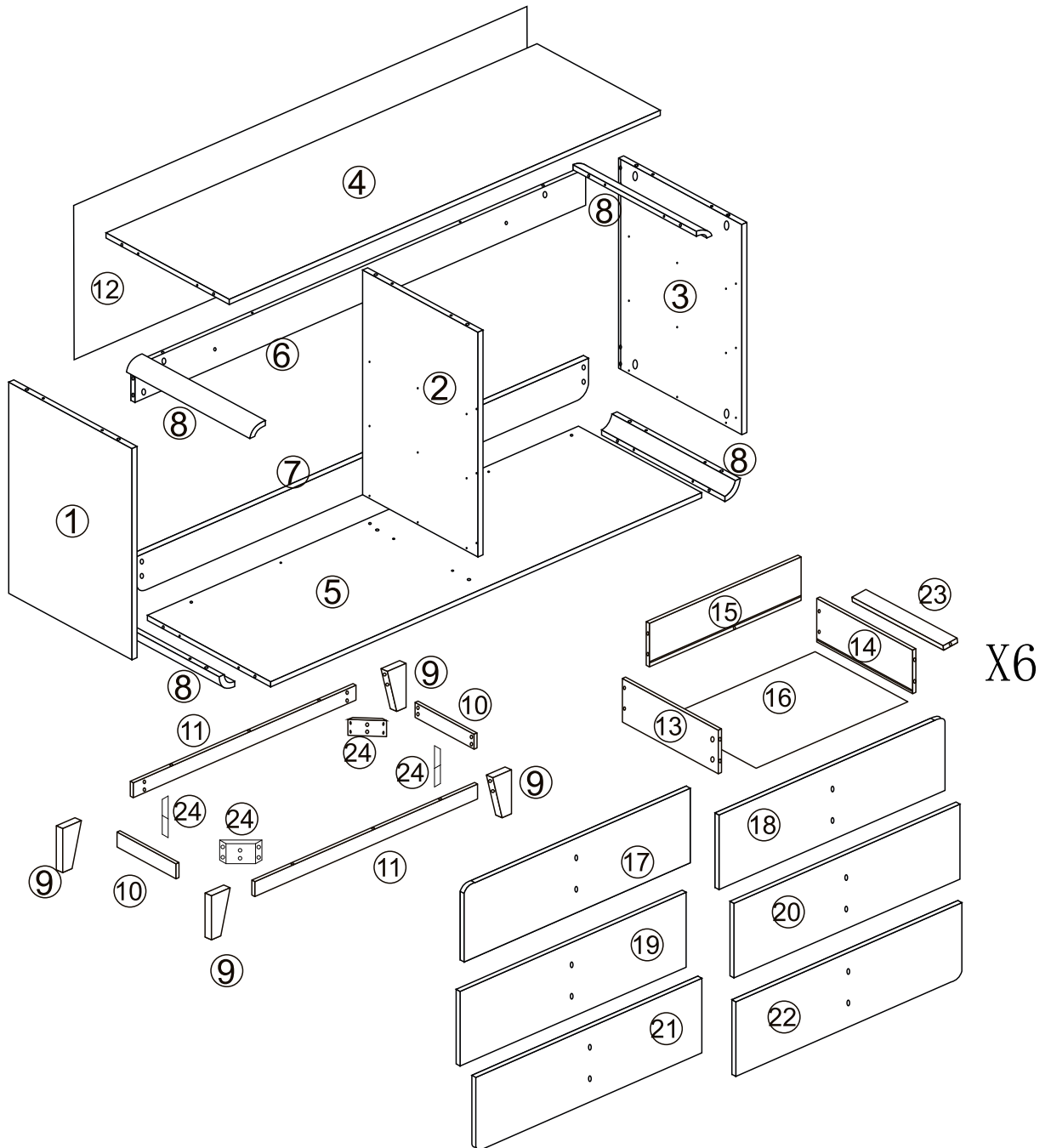

BEFORE YOU START

- Read through each step carefully and follow the proper order
- Separate and count all your parts and hardware
- Give yourself enough room for the assembly process
- Have the following tools:Flat Head Screwdriver,#2 Phillips Head Screwdriver and Hammer
- Caution: IF using a power drill or power screwdriver for screwing,please be aware to slow down and stop when screw is tight.Failure to do so may result in stripping the screw.

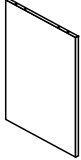

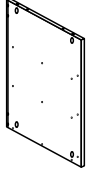
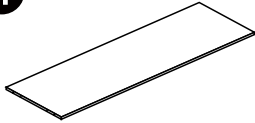
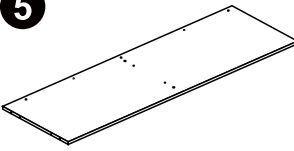
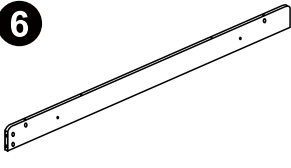
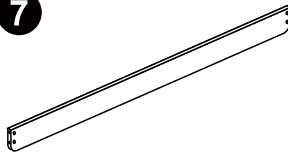
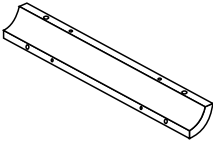

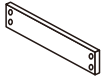
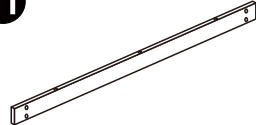
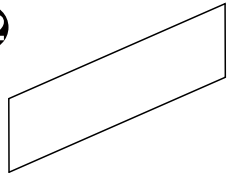
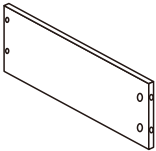
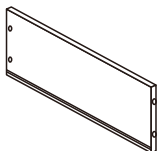
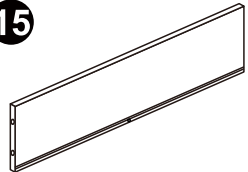
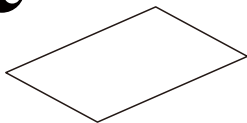
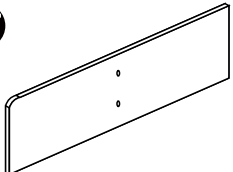
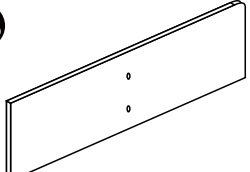
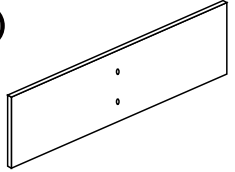
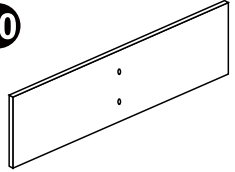
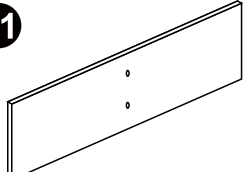
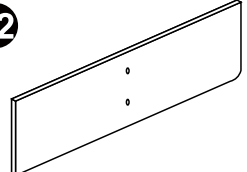







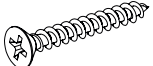



BOARD IDENTIFICATION

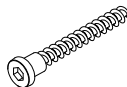
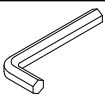

BOARD IDENTIFICATION

<p>1</p>  <p>1PC</p>	<p>2</p>  <p>1PC</p>	<p>3</p>  <p>1PC</p>	<p>4</p>  <p>1PC</p>
<p>5</p>  <p>1PC</p>	<p>6</p>  <p>1PC</p>	<p>7</p>  <p>1PC</p>	<p>8</p>  <p>4PCS</p>
<p>9</p>  <p>4PCS</p>	<p>10</p>  <p>2PCS</p>	<p>11</p>  <p>2PCS</p>	<p>12</p>  <p>1PC</p>
<p>13</p>  <p>6PCS</p>	<p>14</p>  <p>6PCS</p>	<p>15</p>  <p>6PCS</p>	<p>16</p>  <p>6PCS</p>
<p>17</p>  <p>1PC</p>	<p>18</p>  <p>1PC</p>	<p>19</p>  <p>1PC</p>	<p>20</p>  <p>1PC</p>
<p>21</p>  <p>1PC</p>	<p>22</p>  <p>1PC</p>	<p>23</p>  <p>6PCS</p>	<p>24</p>  <p>4PCS</p>

THE HARDWARE

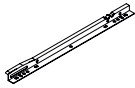
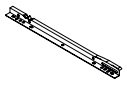
A	B	C 8x30mm	D 4x35mm	E 4x50mm
				
Cam Bolt	Cam Lock	Wood Dowel	Screw	Screw
58 PCS	58 PCS	28 PCS	35 PCS	8 PCS
F	G 3.5x12mm	H	I	J 5x40mm
				
Cover	Screw	Wall Anchor	Handle	Bolt
24 PCS	84 PCS	2 PCS	4 PCS	8 PCS
K	L	M 6x20mm	N	O 4x22mm
				
Hex Key Wrench	Handle	Screw	wedge	Screw
1 PC	2 PCS	12 PCS	6 PCS	16 PCS
P	CL	CR	DL	DR
				
Pads	Drawer Slide Kit	Drawer Slide Kit	Drawer Slide Kit	Drawer Slide Kit
4 PCS	6 PCS	6 PCS	6 PCS	6 PCS

IMPORTANT :



1. Do not tighten bolts / screws completely until all bolts / screws are lined up and inserted into holes.
2. Do not over tighten screws and bolts to avoid stripping.
3. Please use hand tools to assemble this product. Do not use power tools.

CAM LOCK FASTENING SYSTEM

This Cam Lock Fastening System will be used throughout the assembly process.

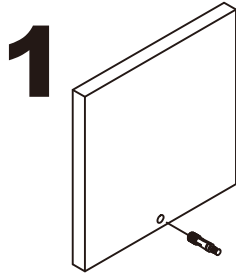

1
Press CAM BOLT into hole.

2

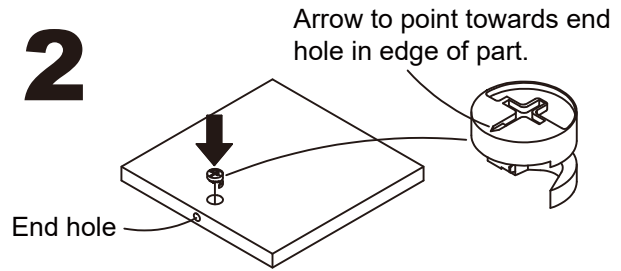

Press CAM LOCK into hole.

3

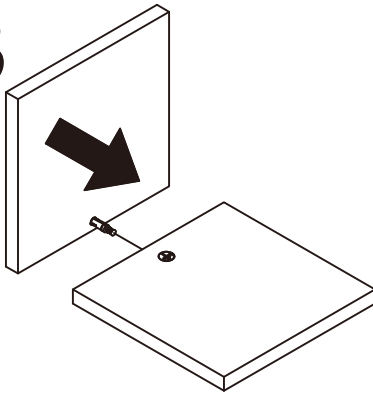

Press parts together so CAM BOLT inserts into edge hole.

4

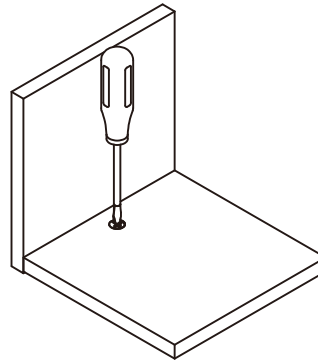

Using a screwdriver, turn the CAM LOCK clockwise to lock the CAM LOCK and CAM BOLT into their holes and fastening parts together.

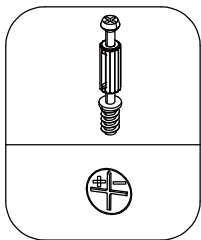

Notice: Proper orientation of CAM LOCK

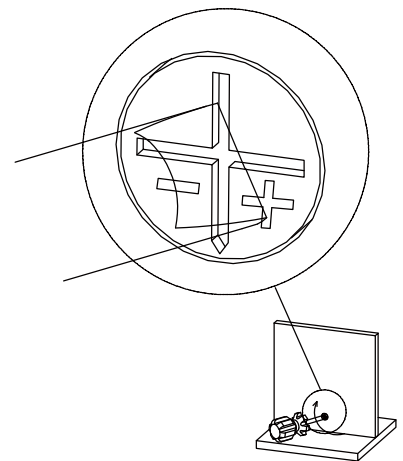
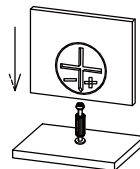
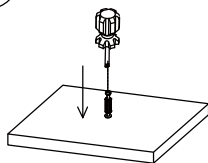
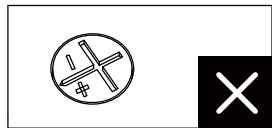
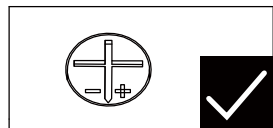

INSTALLATION STEPS

STEP 1

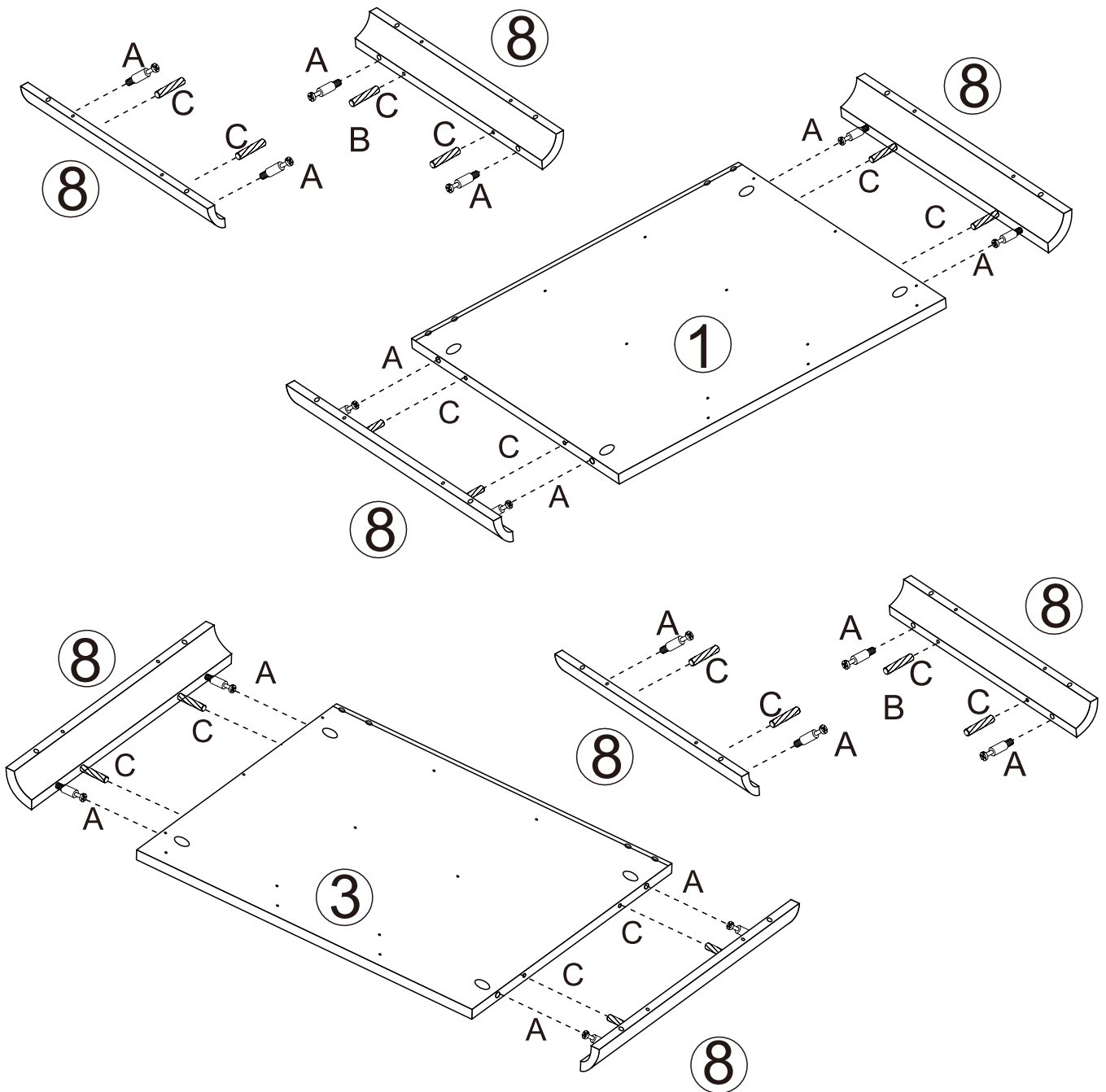
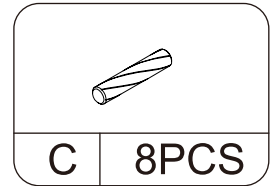
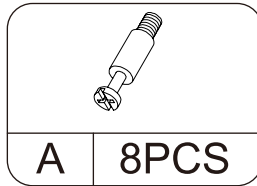

INSTALLATION STEPS

STEP 2

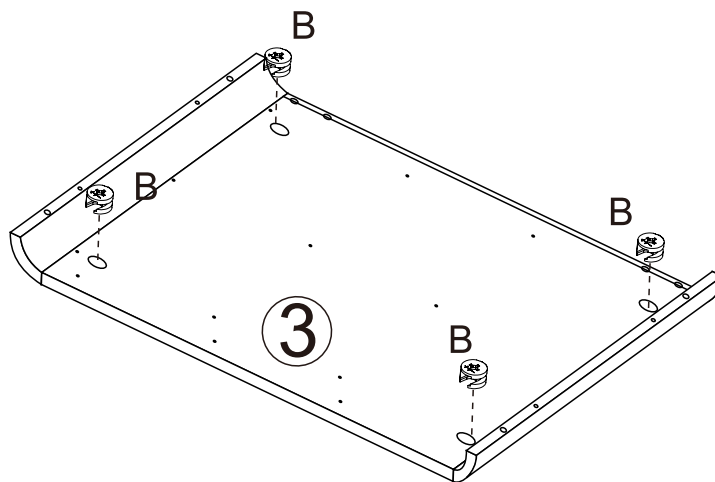
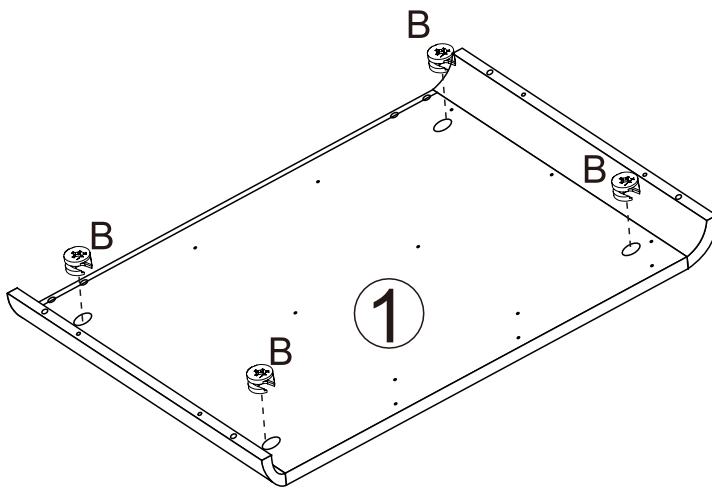
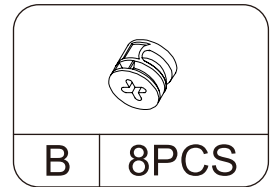

INSTALLATION STEPS

STEP 3



G	24PCS
---	-------

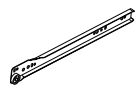

CL	3PCS
----	------

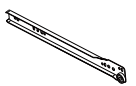

CR	3PCS
----	------

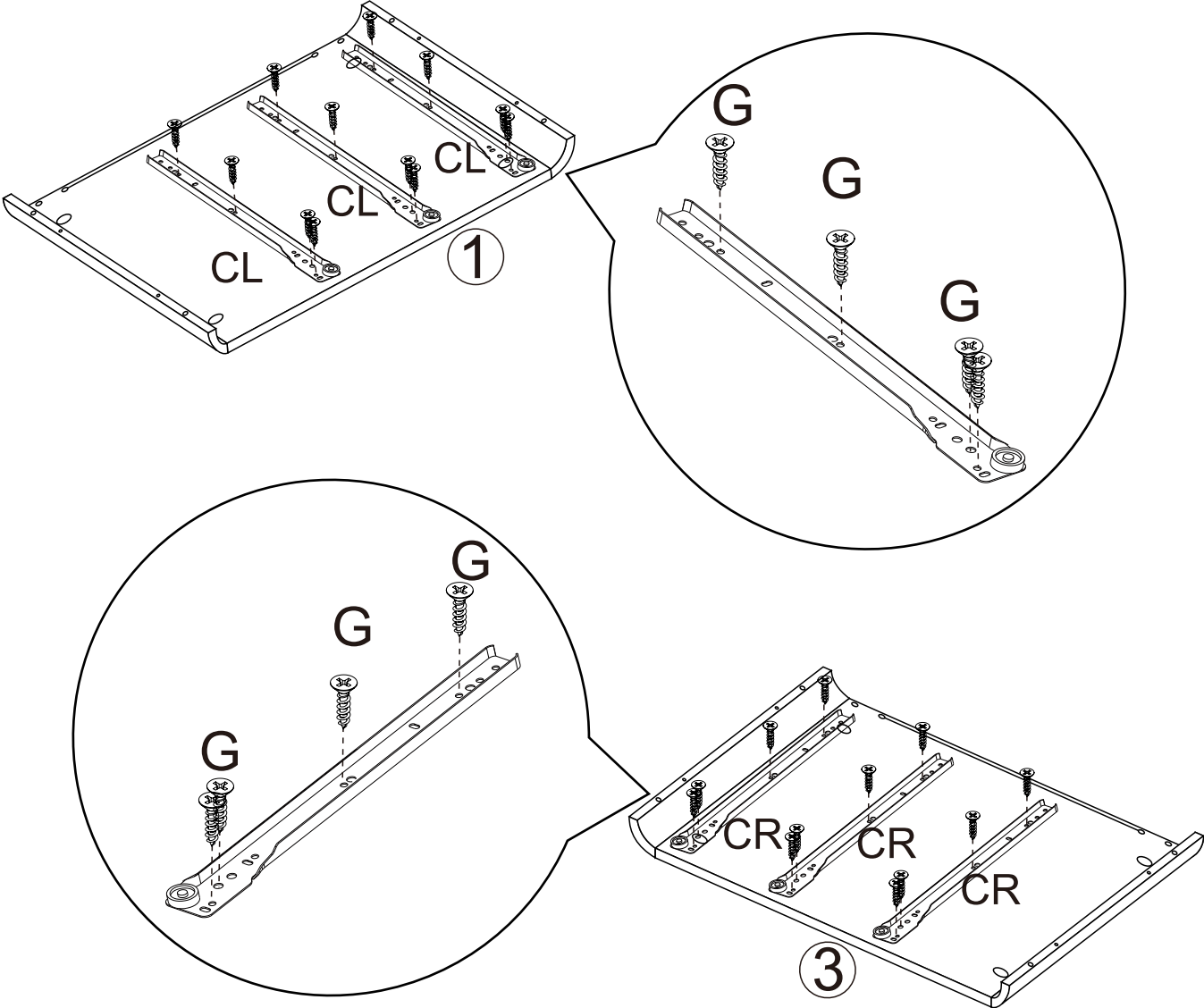

INSTALLATION STEPS

STEP 4

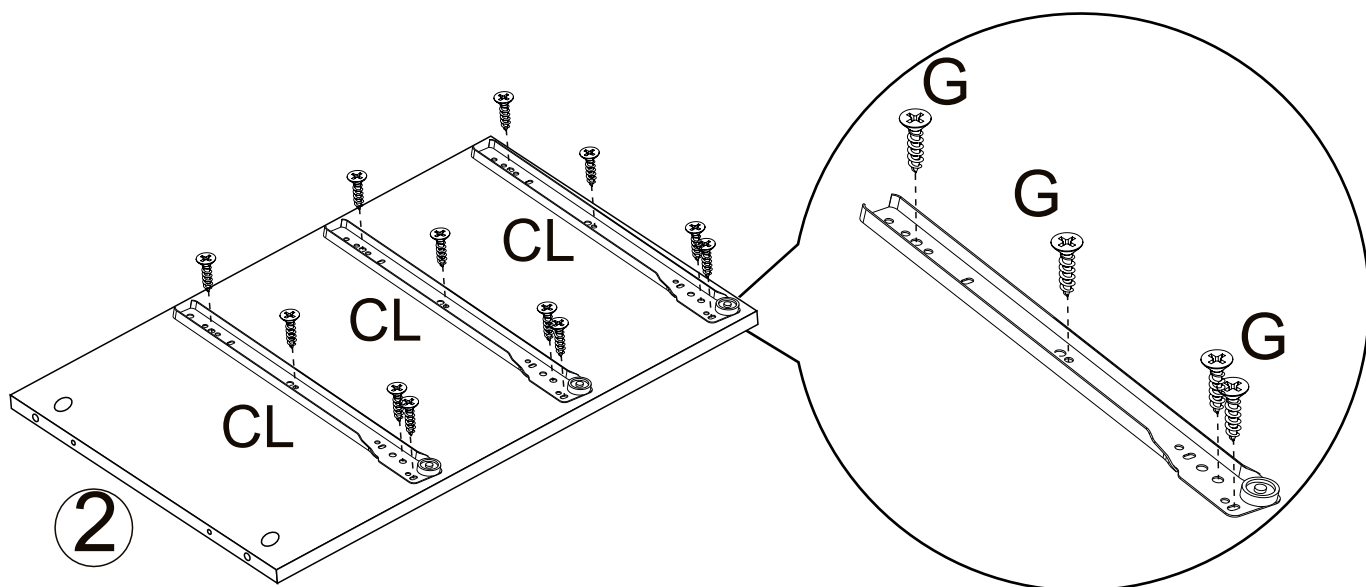
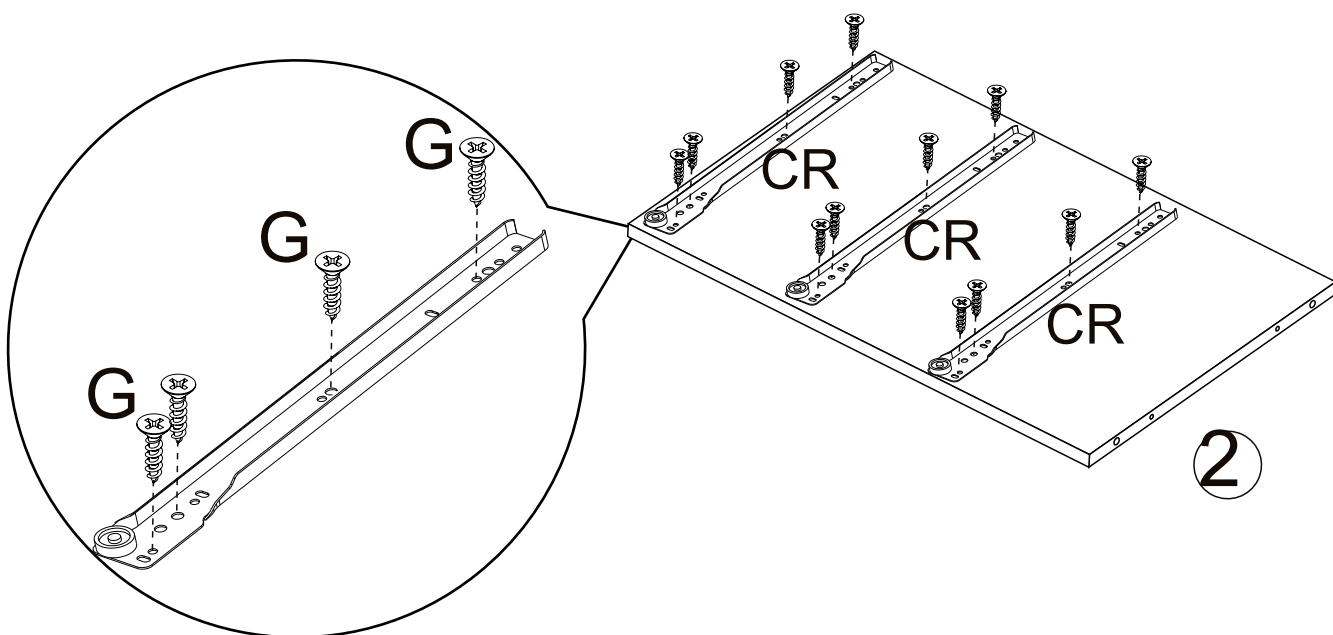
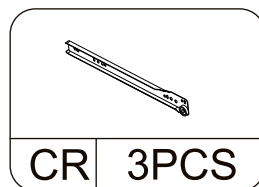
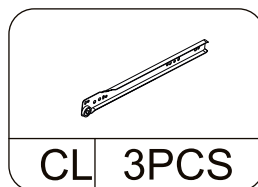
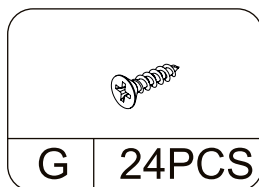

INSTALLATION STEPS

STEP 5

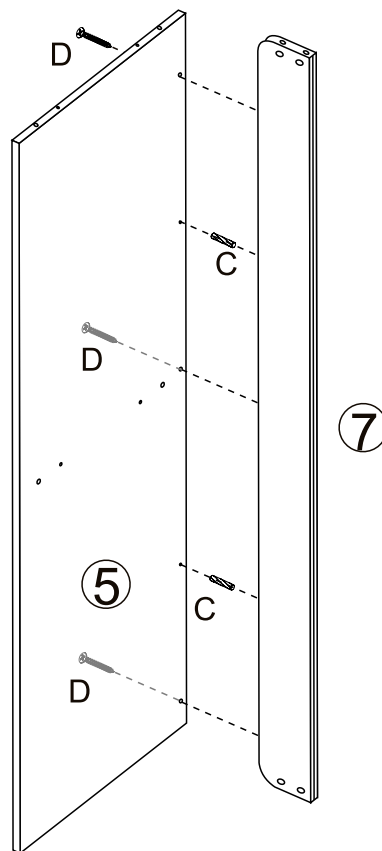
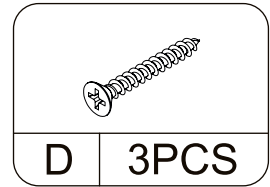
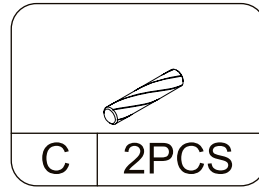

INSTALLATION STEPS

STEP 6

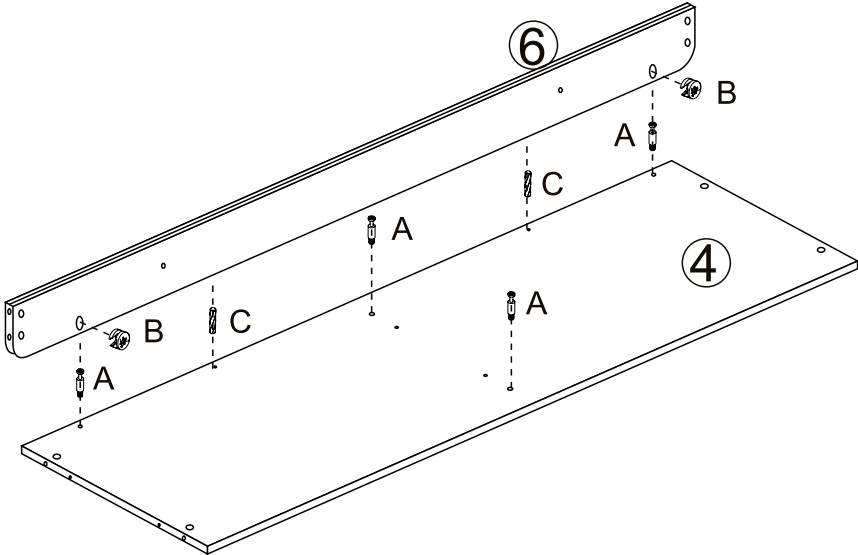
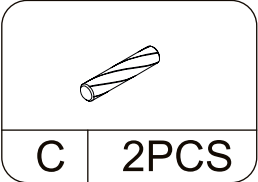
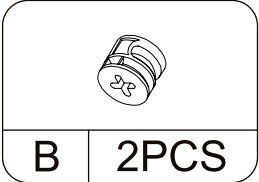
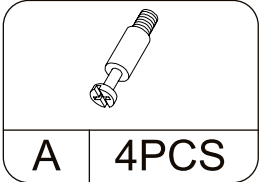

INSTALLATION STEPS

STEP 7

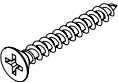

D	2PCS
---	------



B	2PCS
---	------



C	4PCS
---	------

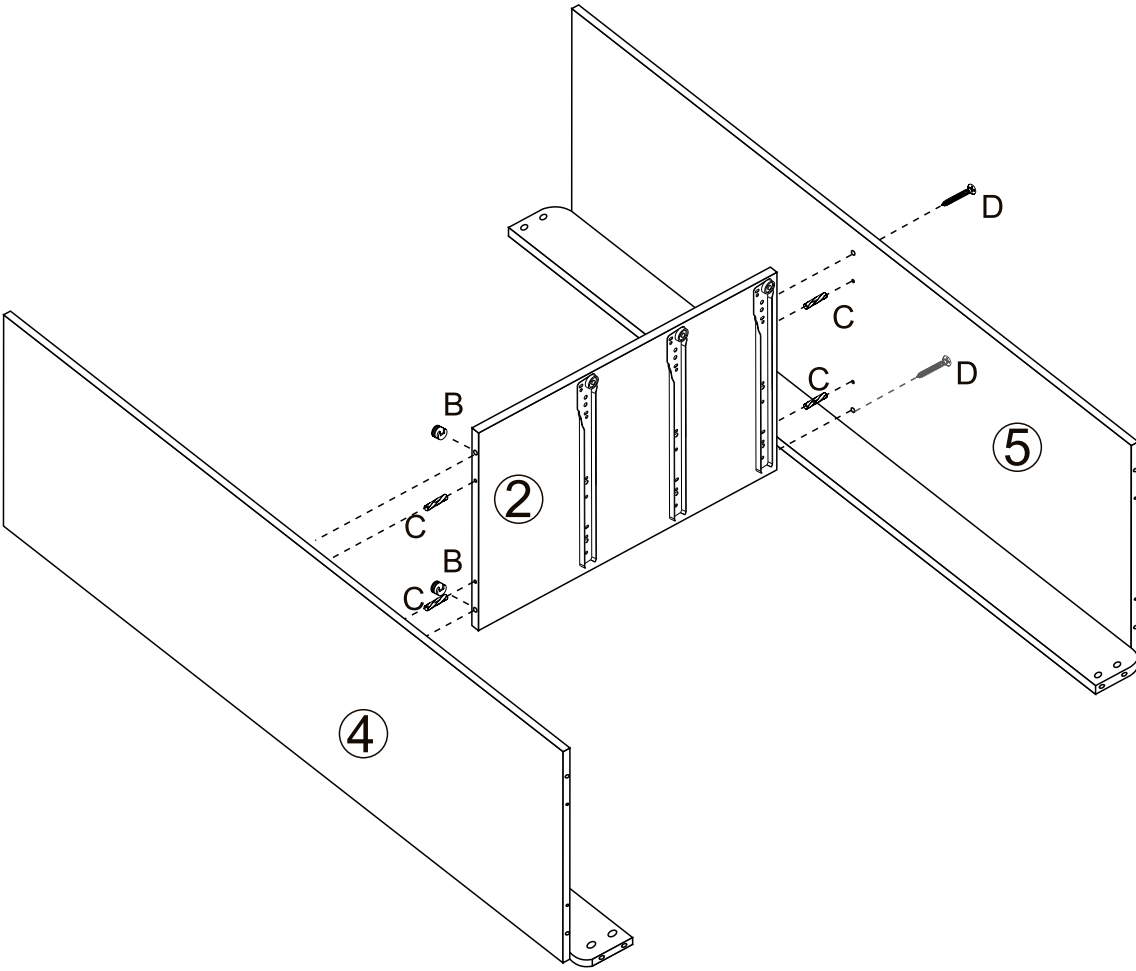

INSTALLATION STEPS

STEP 8

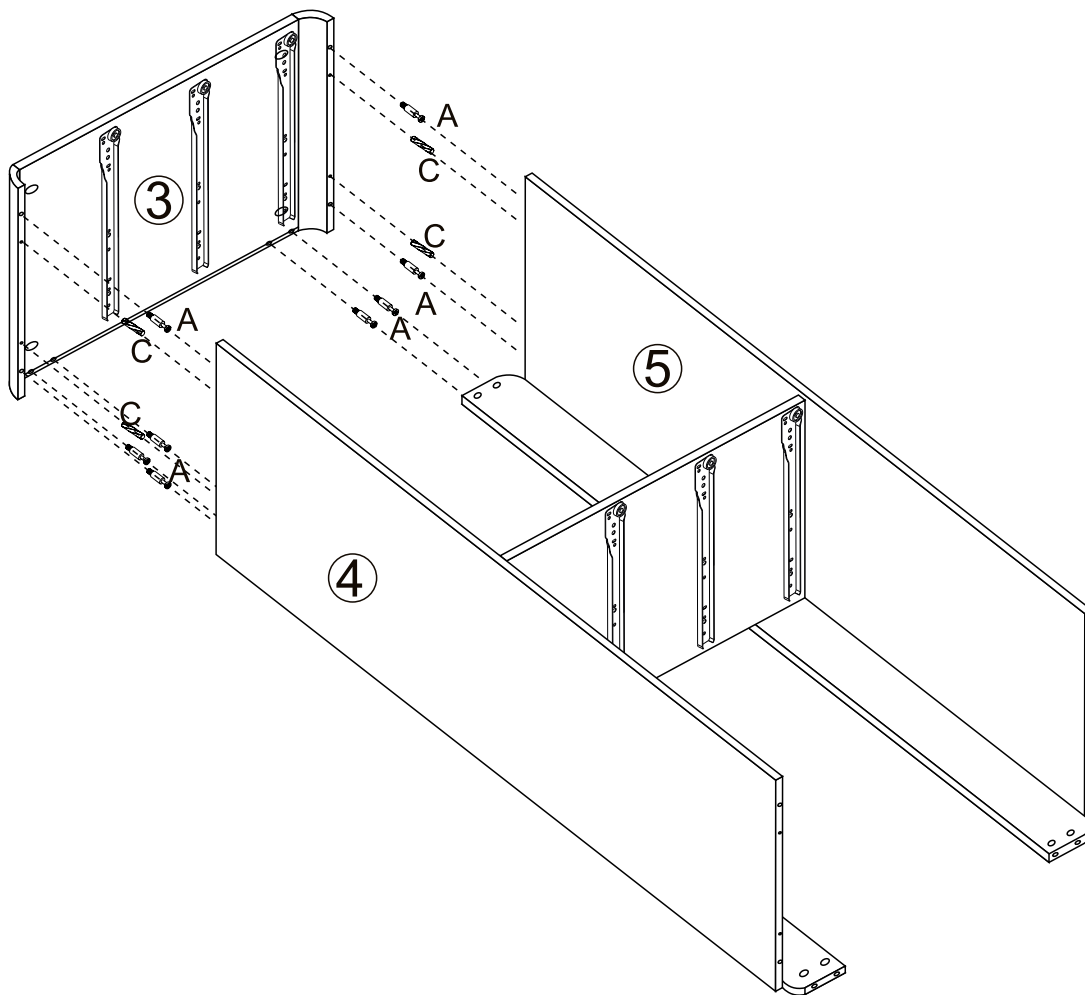
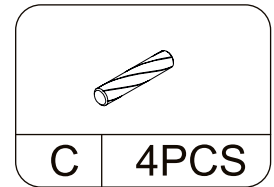
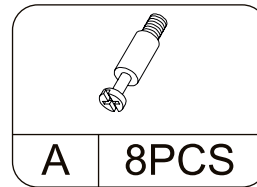

INSTALLATION STEPS

STEP 9

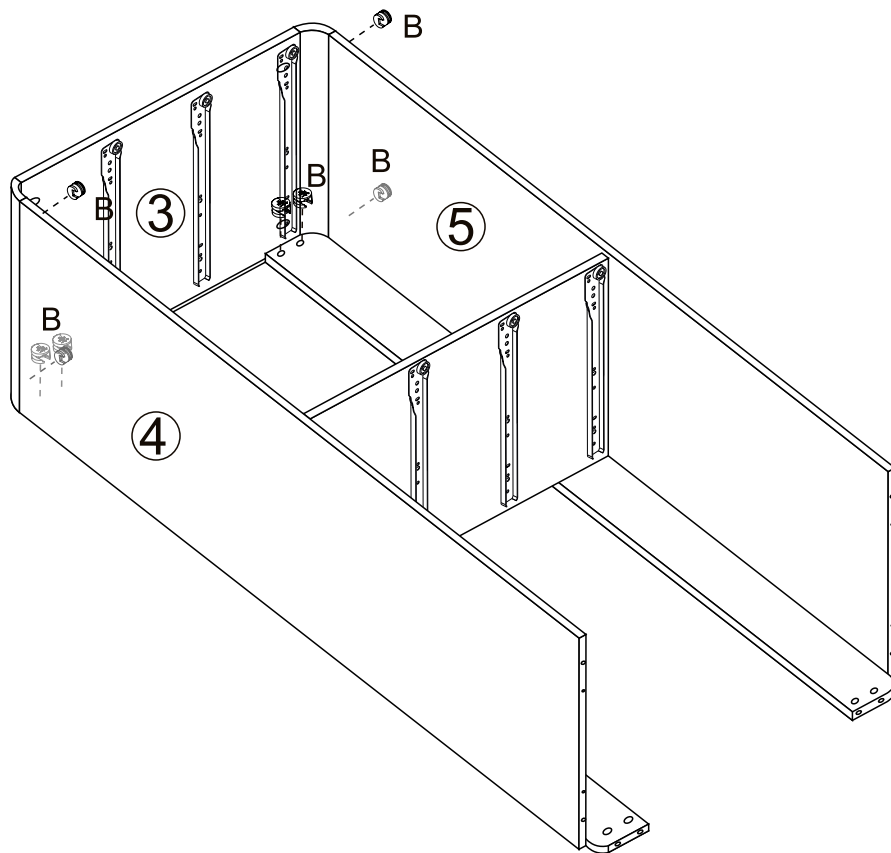
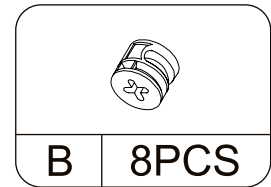

INSTALLATION STEPS

STEP 10

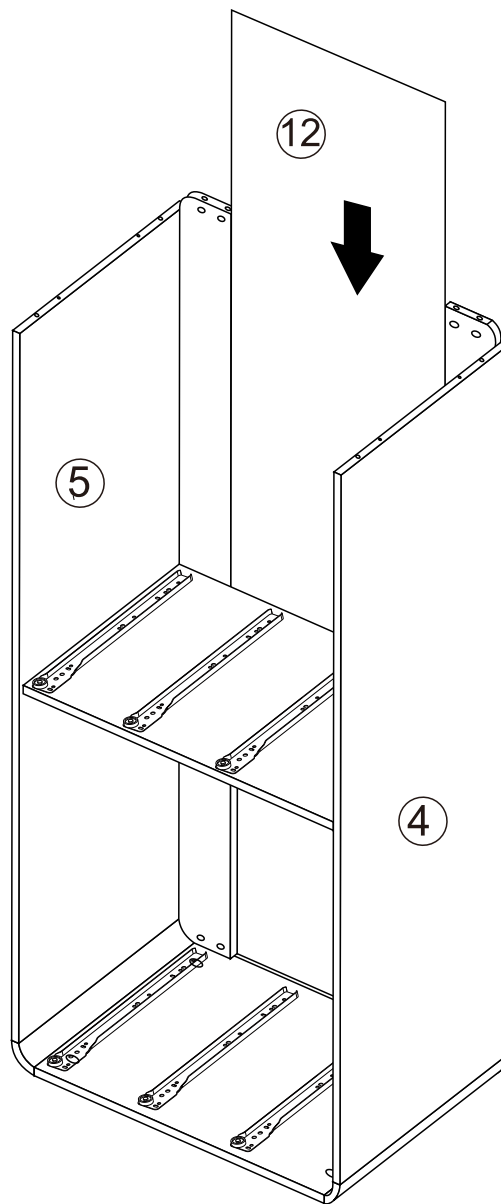

INSTALLATION STEPS

STEP 11

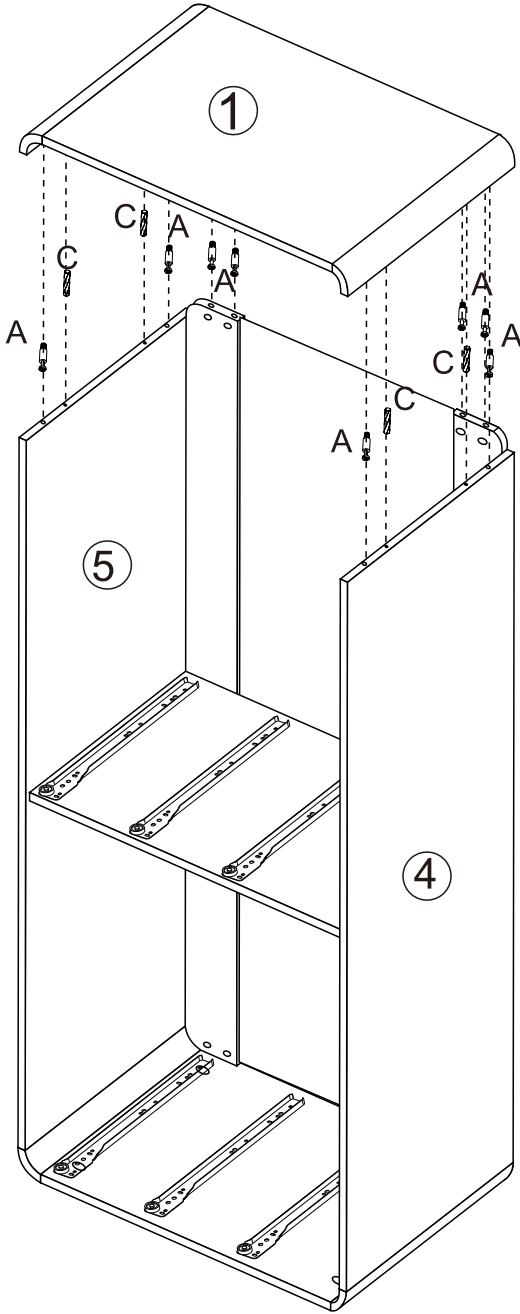
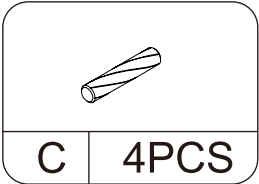
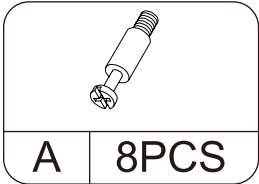

INSTALLATION STEPS

STEP 12

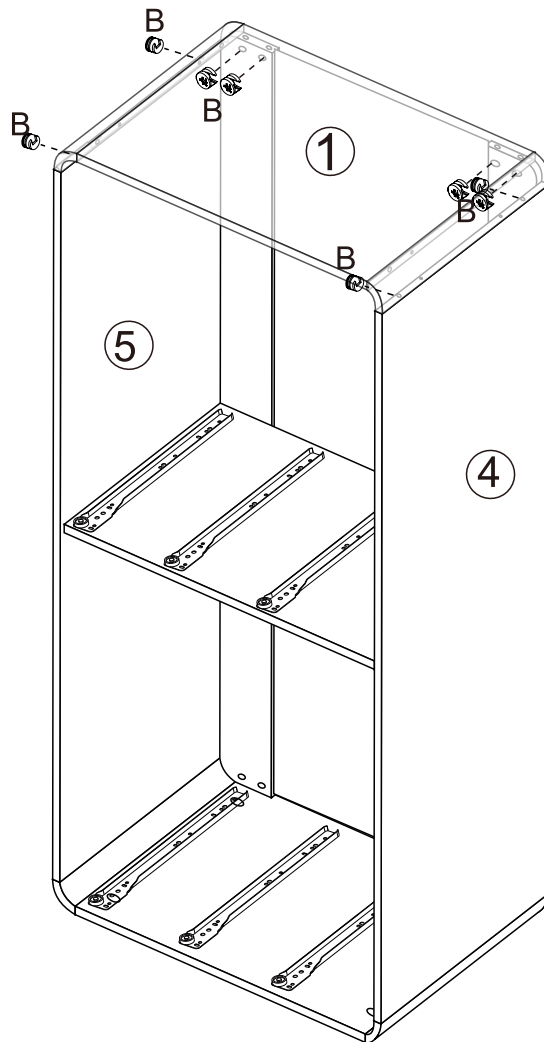
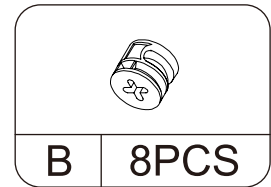

INSTALLATION STEPS

STEP 13

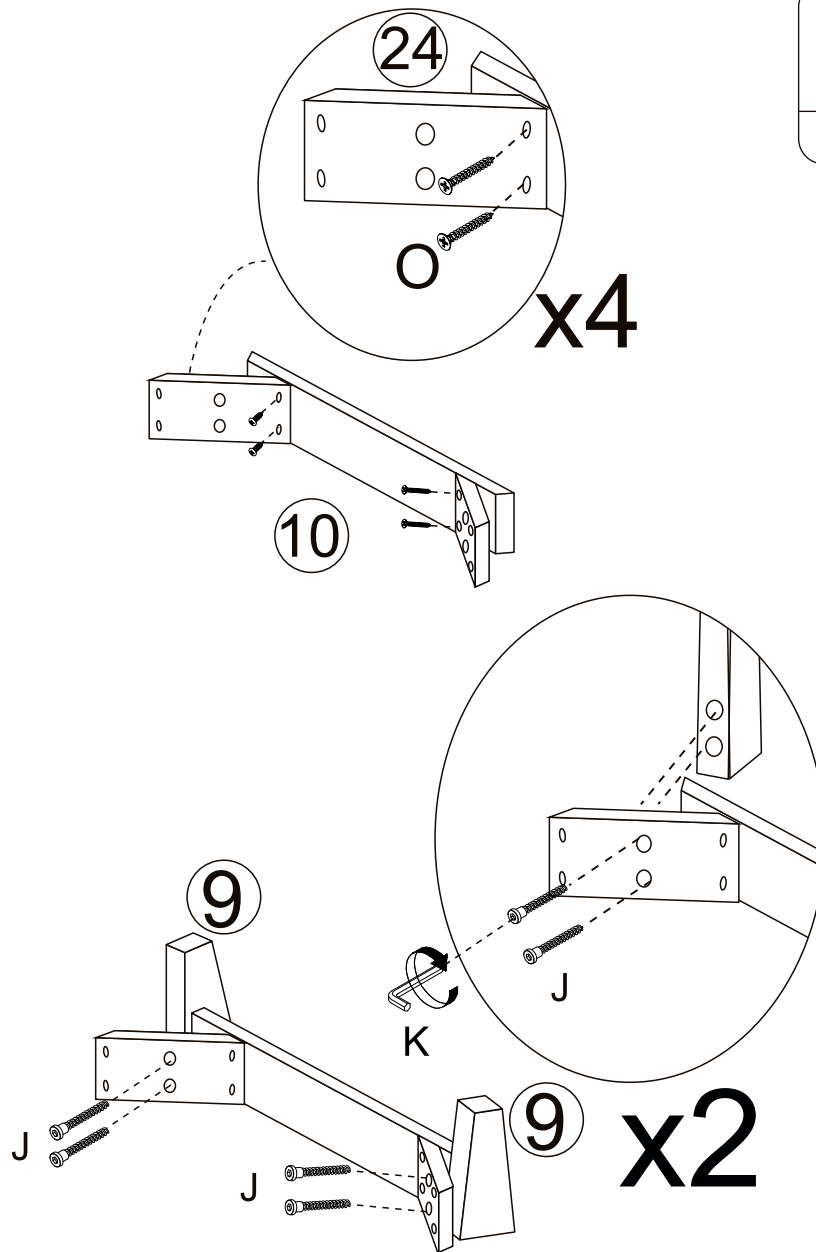
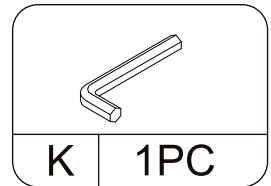
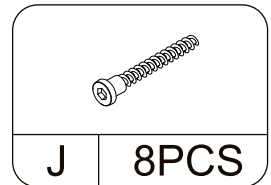
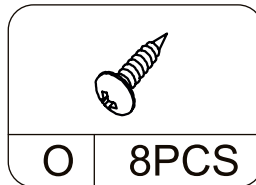

INSTALLATION STEPS

STEP 14

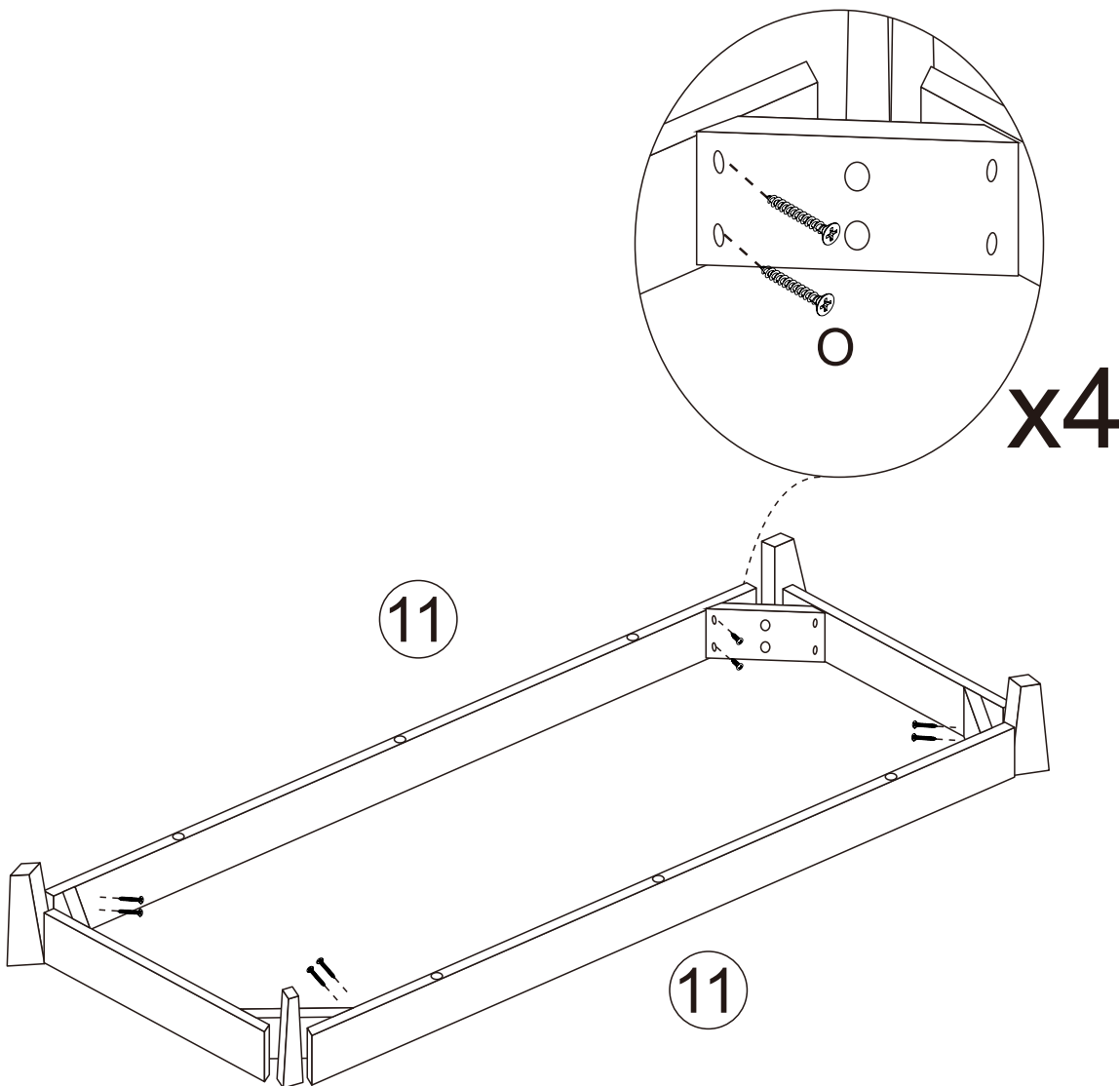
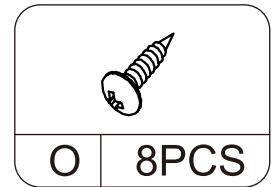

INSTALLATION STEPS

STEP 15

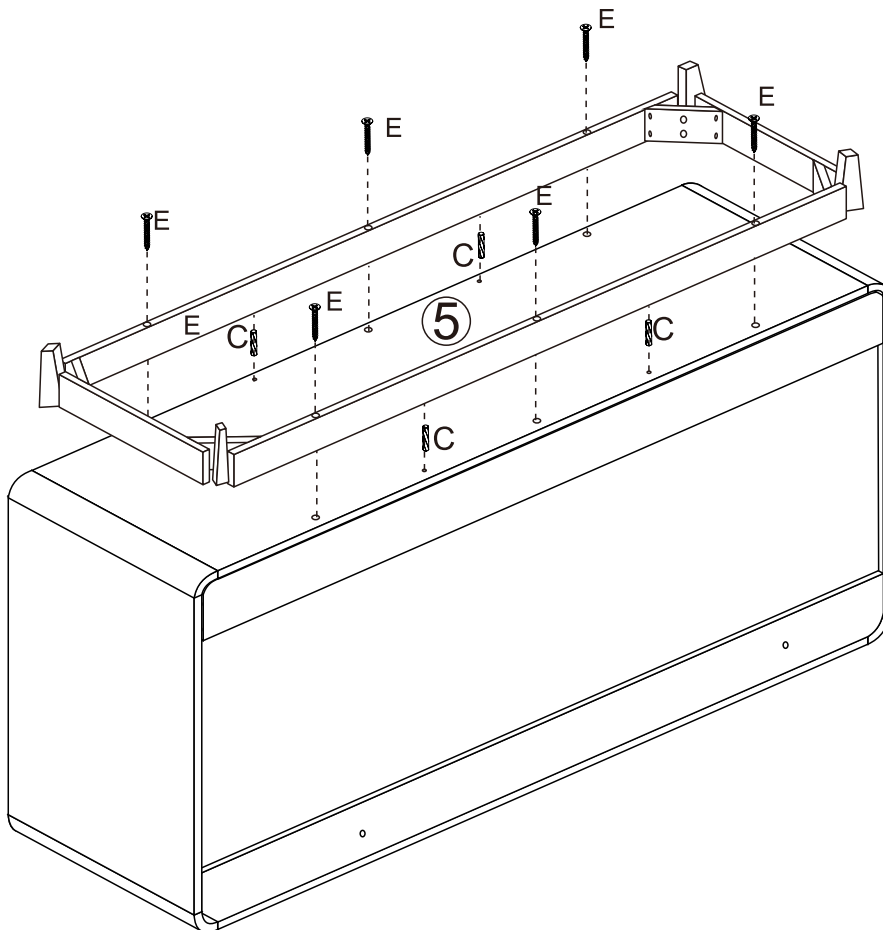
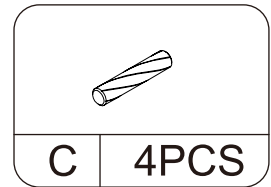
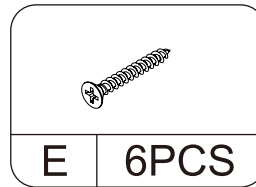

INSTALLATION STEPS

STEP 16

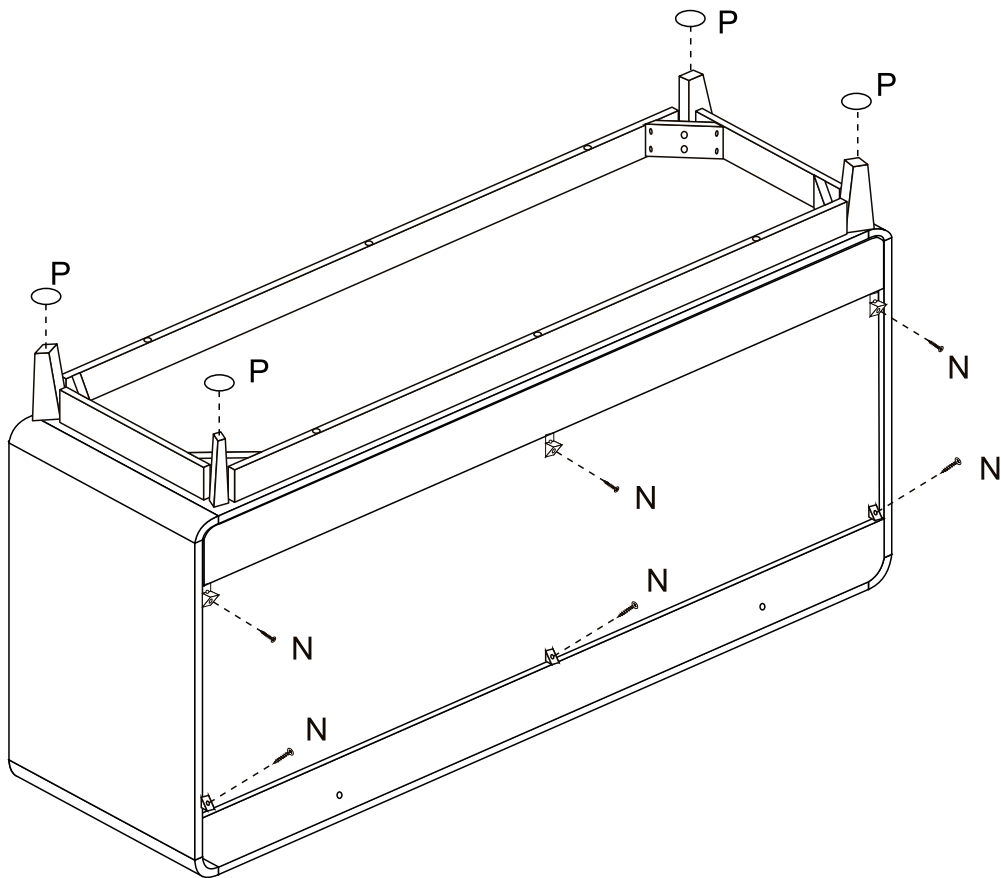
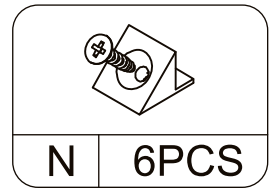
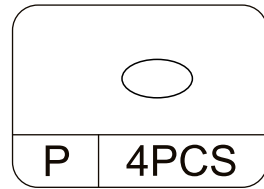

INSTALLATION STEPS

STEP 17

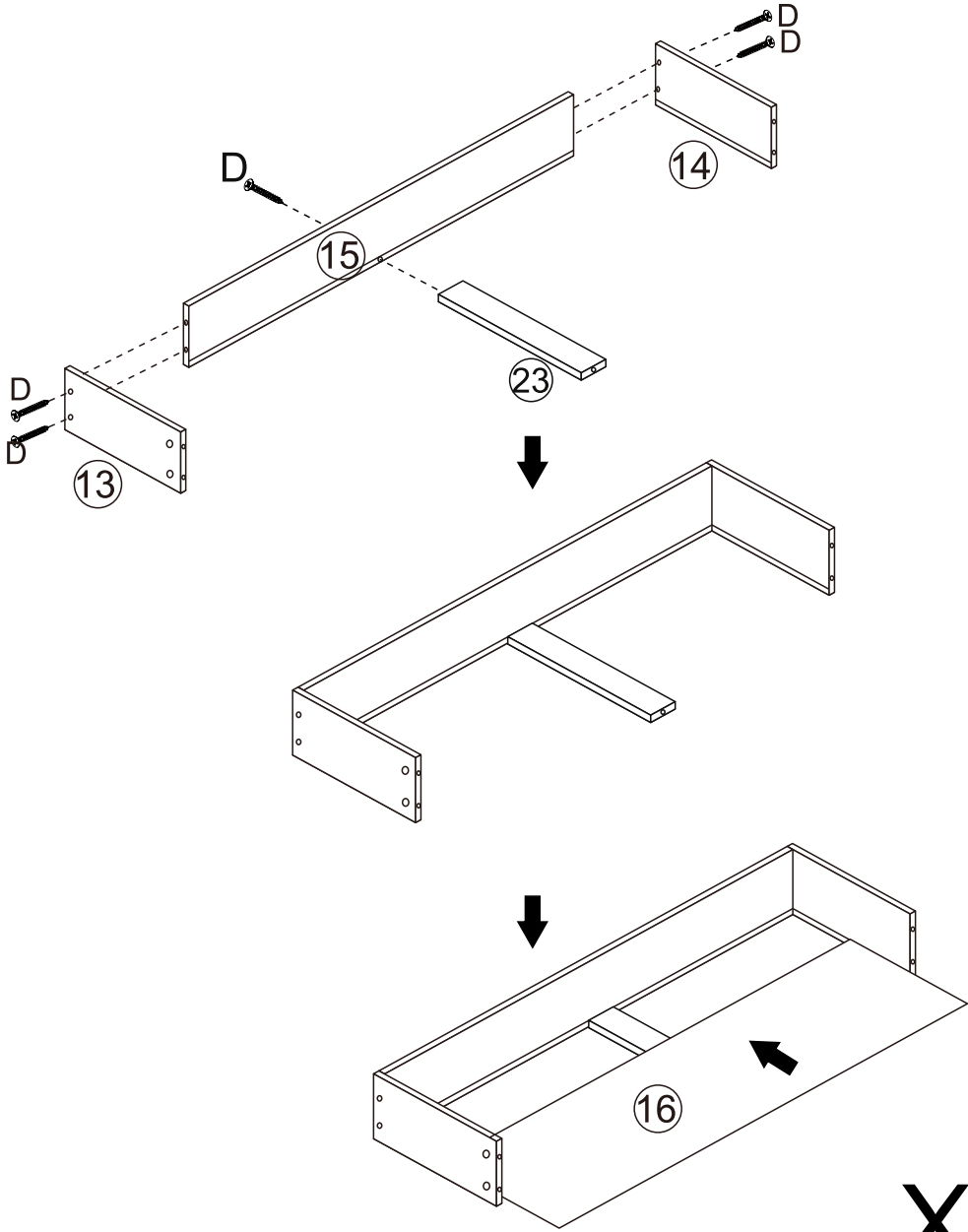
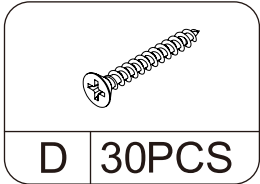

X6

INSTALLATION STEPS

STEP 18

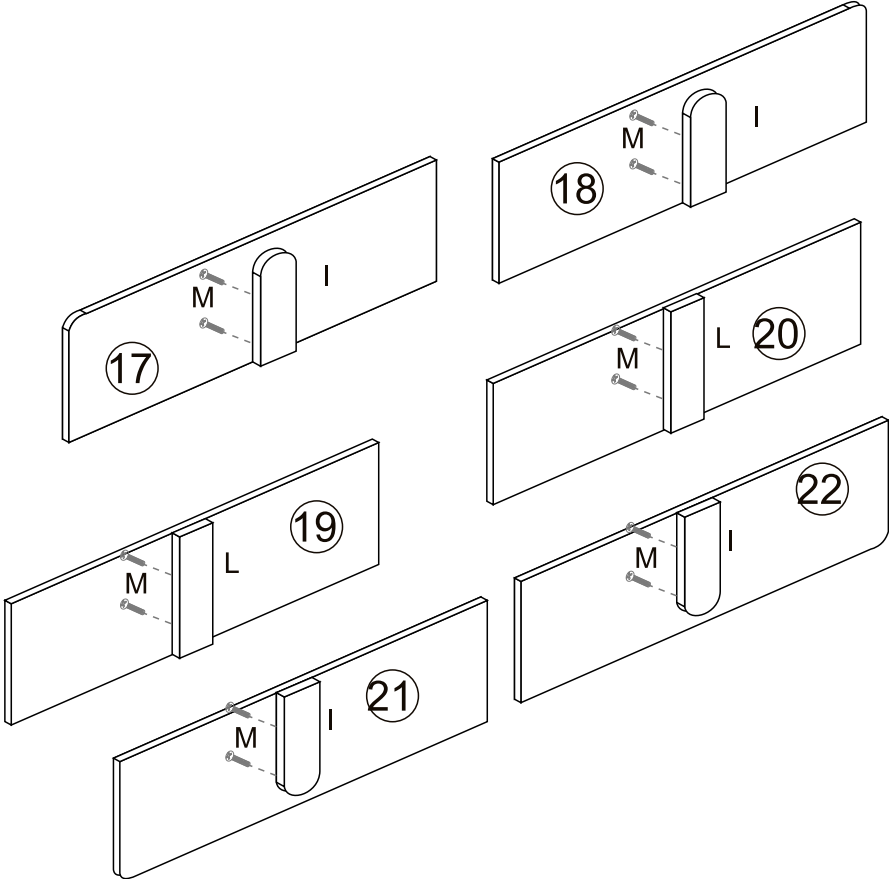
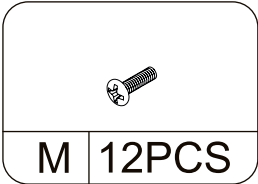
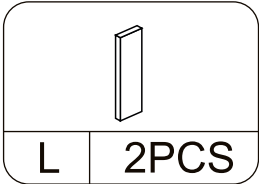
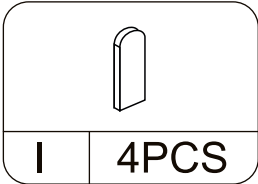

INSTALLATION STEPS

STEP 19

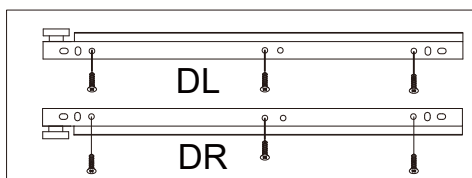
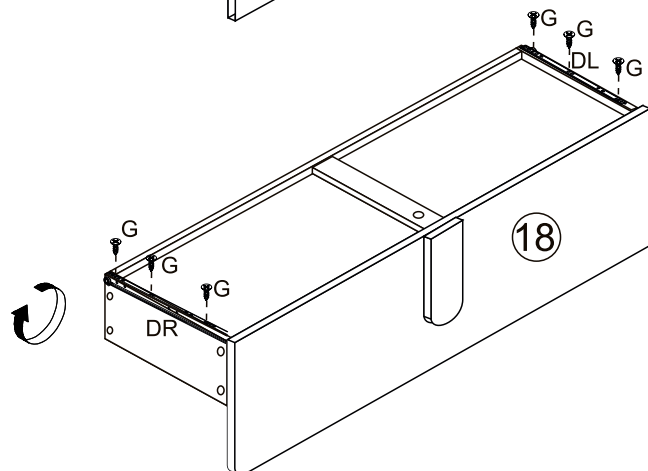
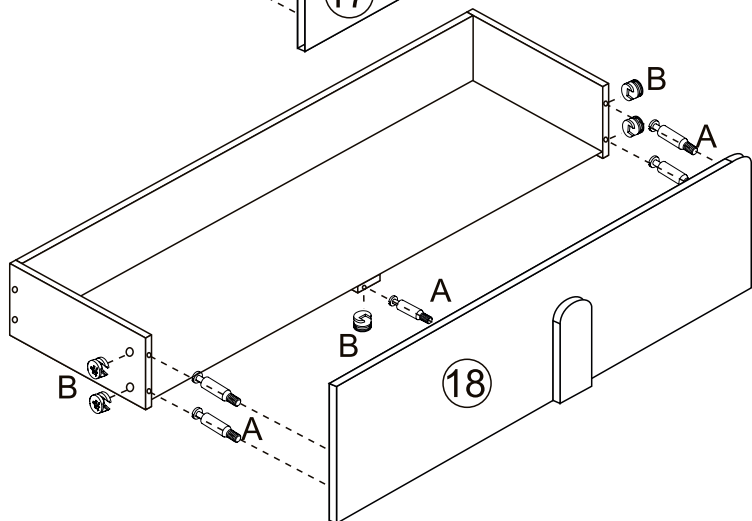
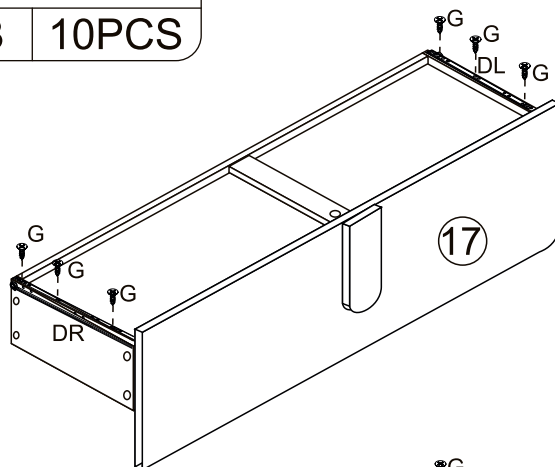
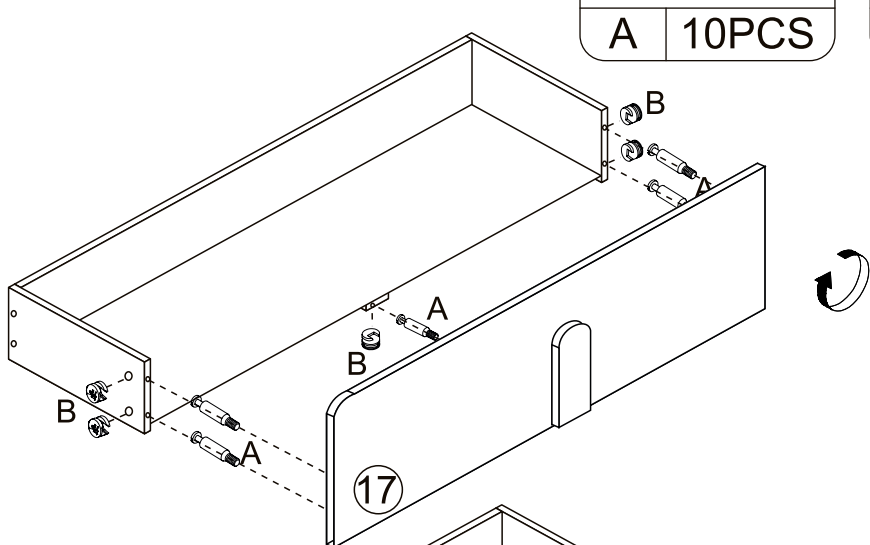
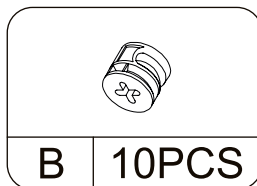
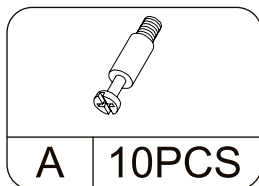
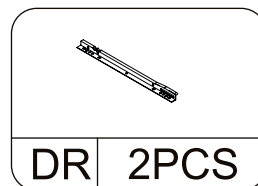
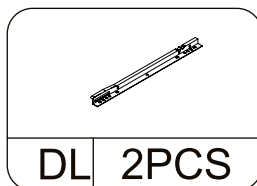
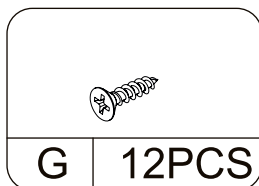

INSTALLATION STEPS

STEP 20

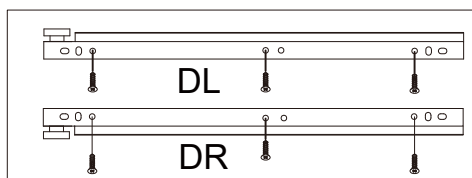
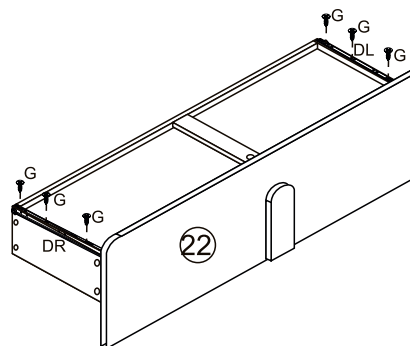
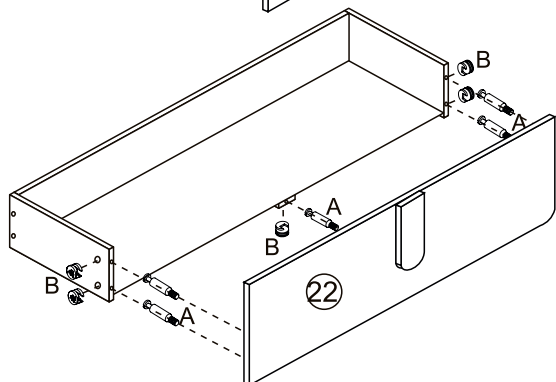
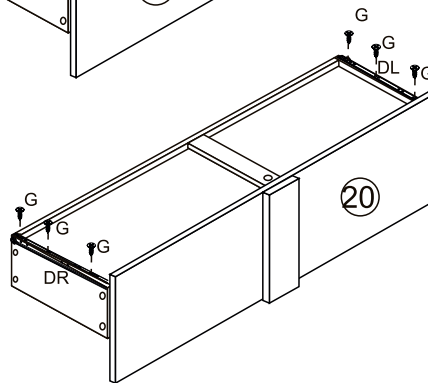
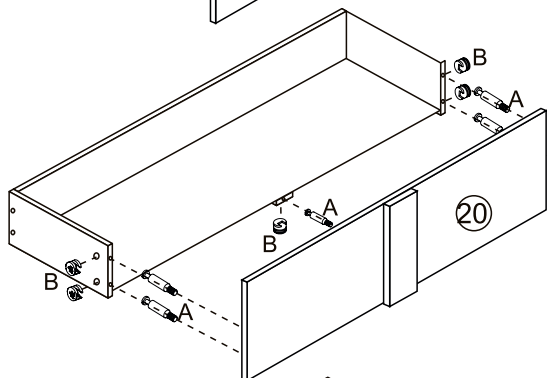
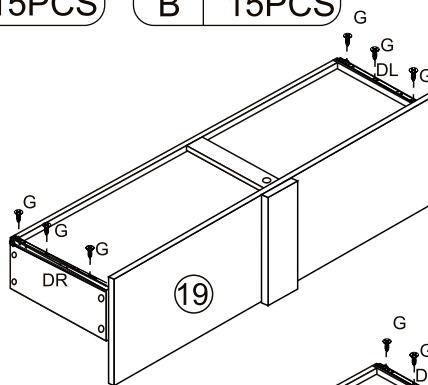
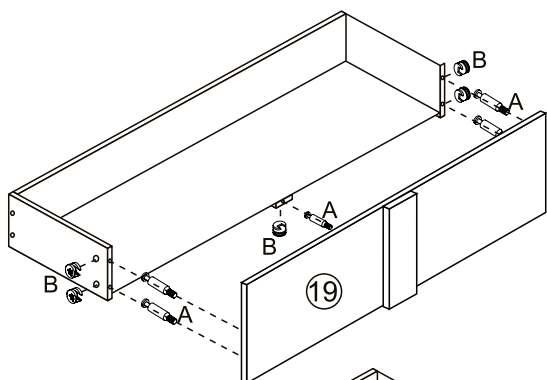
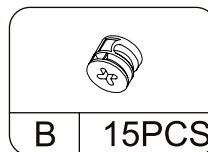
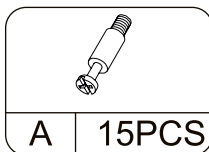
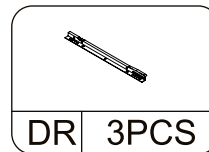
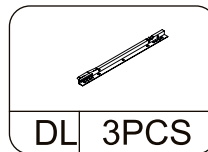
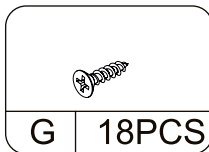

INSTALLATION STEPS

STEP 21

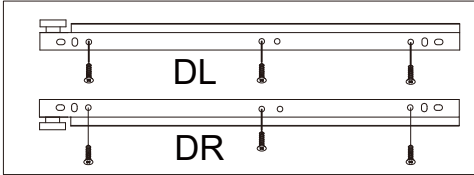
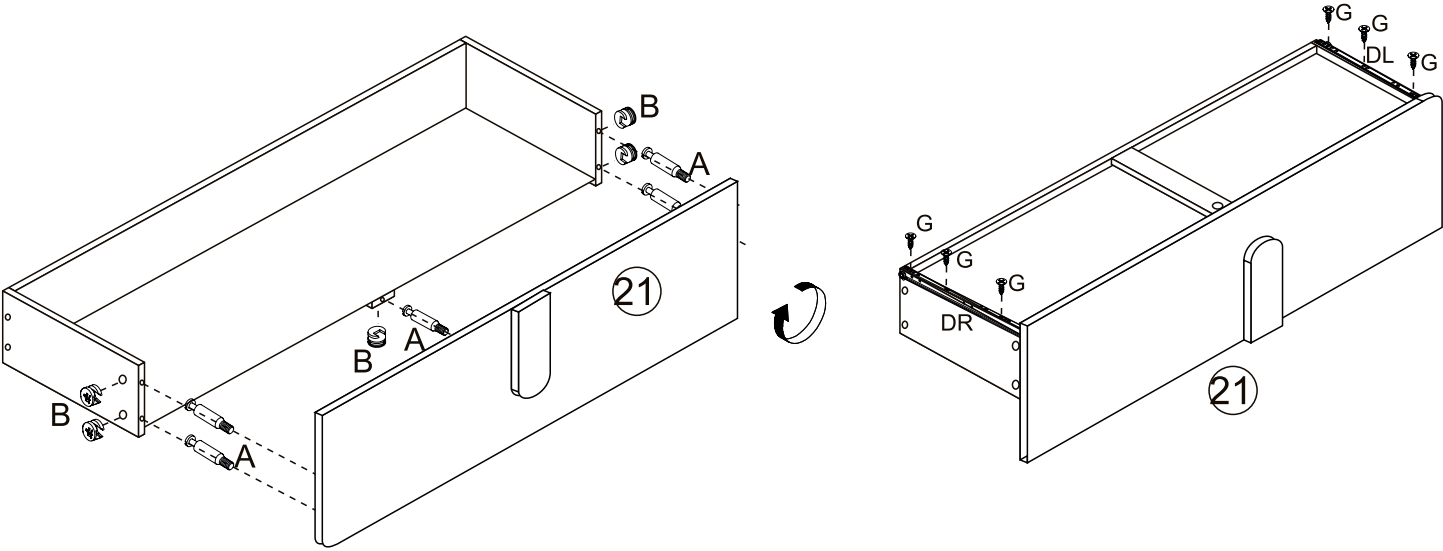
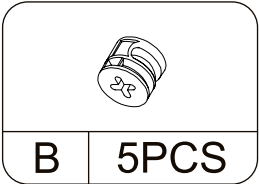
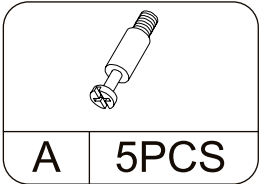
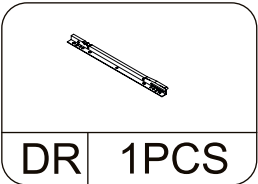
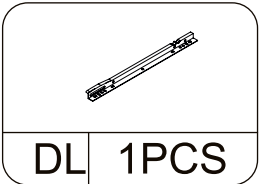
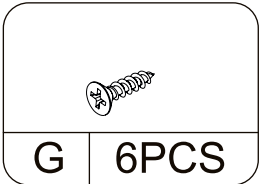

INSTALLATION STEPS

STEP 22

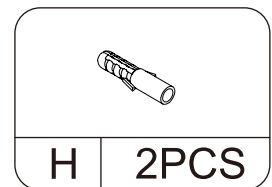
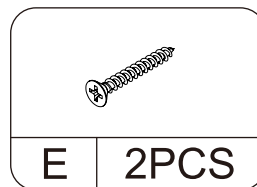

Tips: This step is to install the anti-tipping device system, which requires drilling holes in the wall.

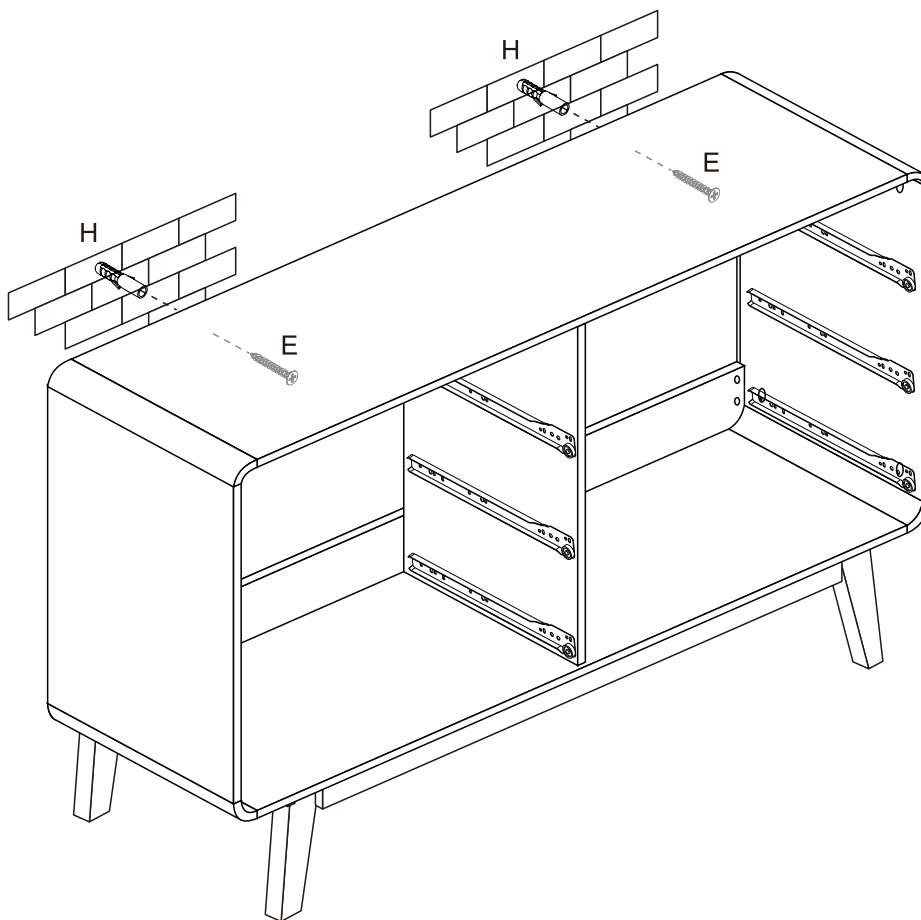

INSTALLATION STEPS

STEP 23

