

EN: Note: Two people are recommended for the assembly. Do not tighten the screws during installation, tighten them after all parts have been installed.

DE: Hinweis: Für die Montage werden zwei Personen empfohlen. Ziehen Sie die Schrauben nicht während der Montage fest, sondern erst nachdem alle Teile montiert sind.

FR: Remarque: Deux personnes sont recommandées pour l'assemblage.
Ne serrez pas les vis pendant l'installation, serrez-les après l'installation de toutes les pièces.

ES: Nota: Se recomiendan dos personas para el montaje. No apriete los tornillos durante el montaje, apriételos después de que se hayan instalado todas las piezas.

IT: Nota: si consigliano due persone per l'assemblaggio. Non serrare le viti durante l'installazione, serrarle dopo che tutte le parti sono state installate.

PL: Uwaga: Zaleca się, aby montażu dokonywały dwie osoby; podczas montażu nie należy dokręcać śrub do końca, śruby dokręć do końca po wstępnym montowaniu wszystkich części.

NL: Opmerking: Voor de montage worden twee personen aanbevolen. Draai de schroeven niet vast tijdens de installatie, maar pas nadat alle onderdelen zijn geïnstalleerd.

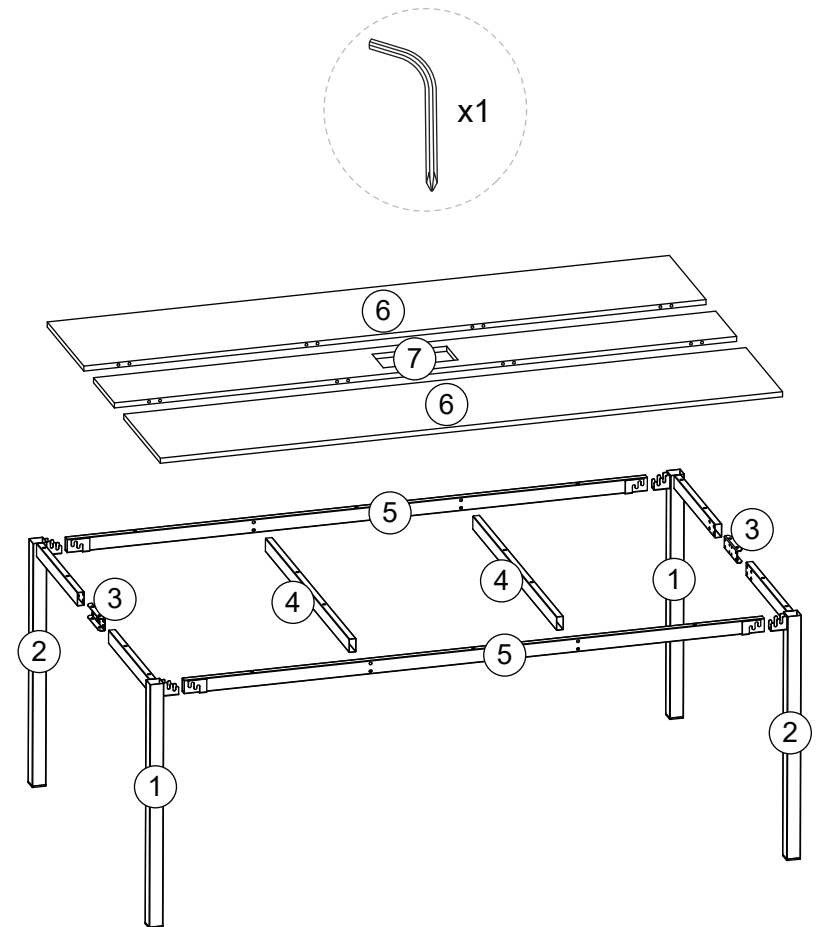

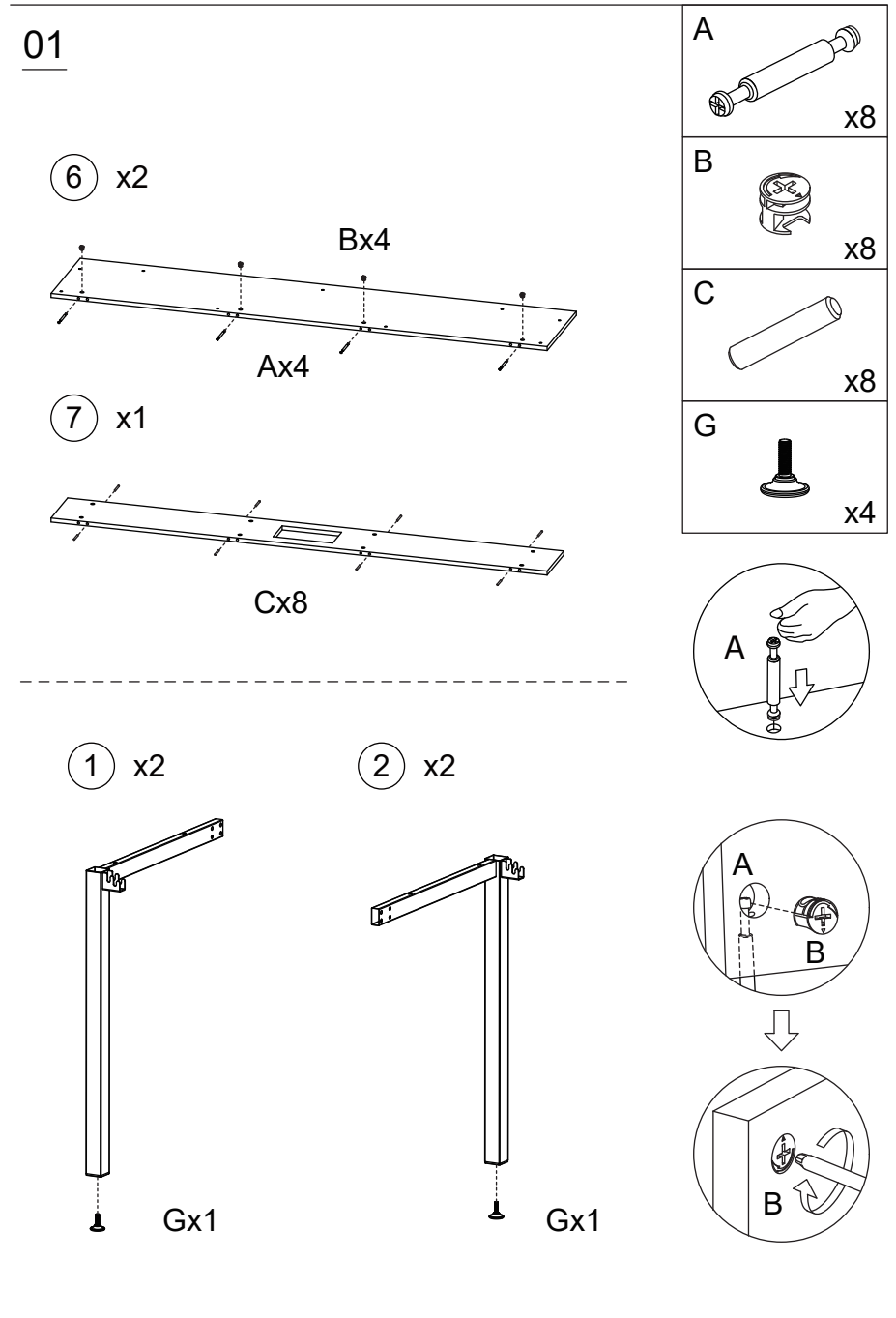
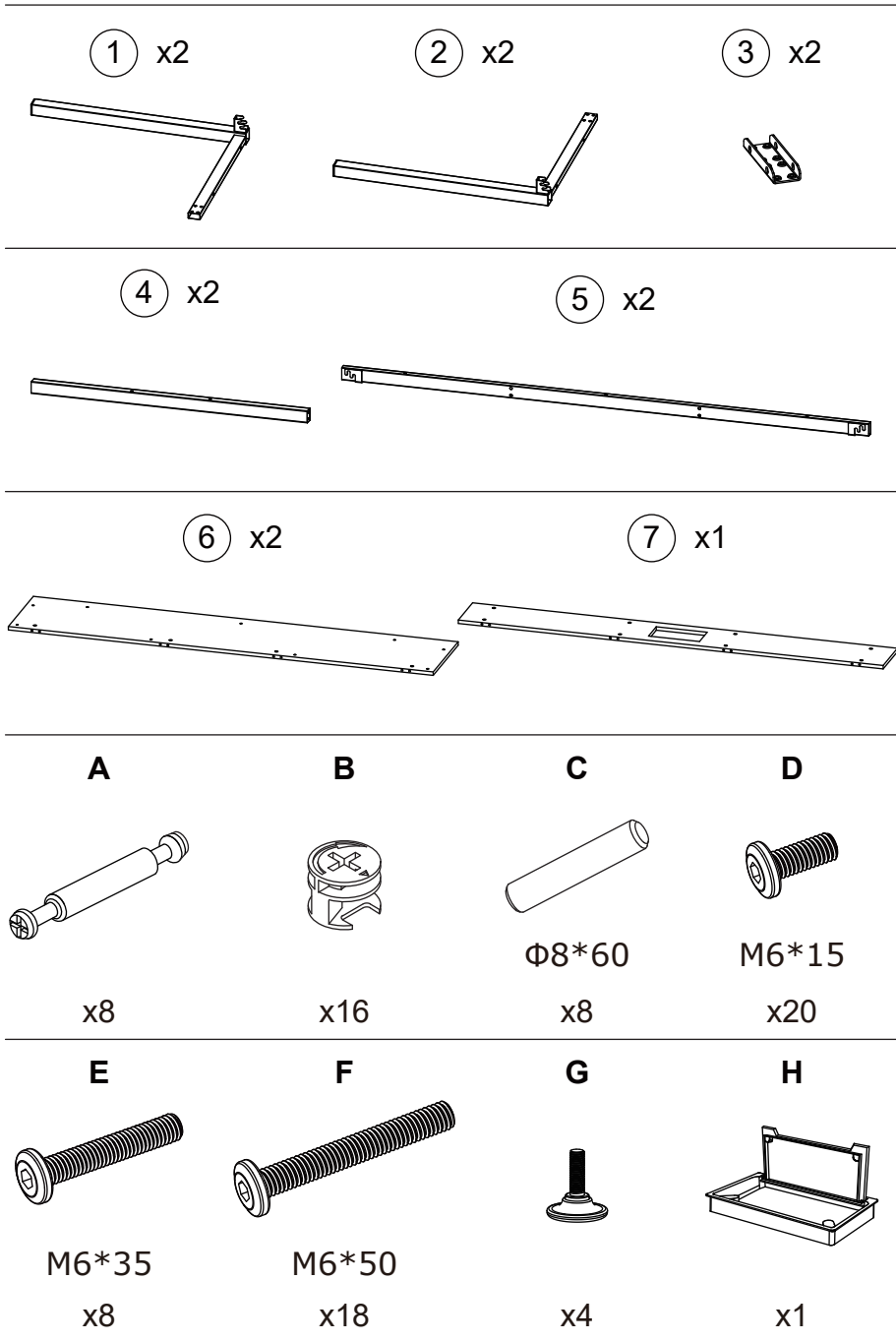

02

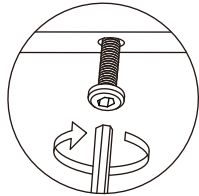
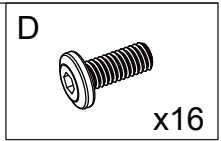

Dx8

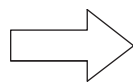
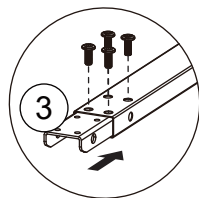
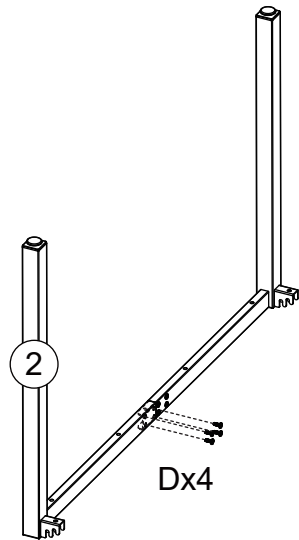
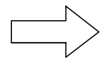
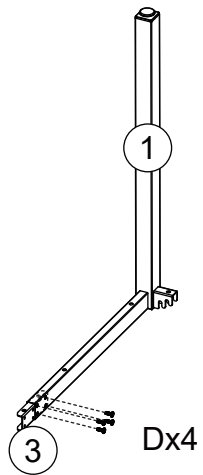

I

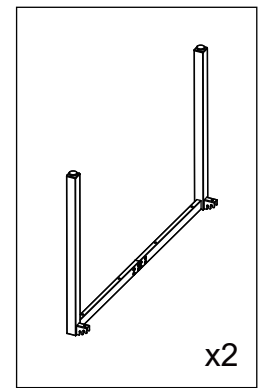
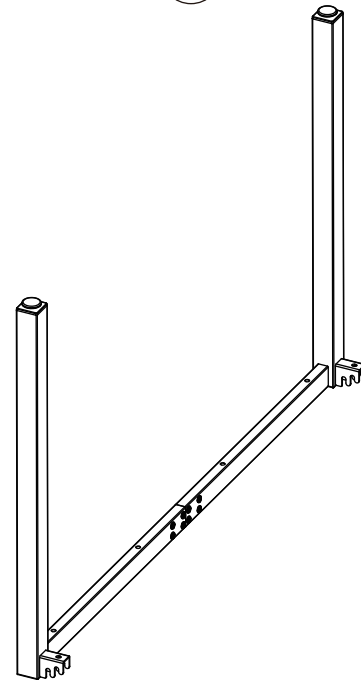

03

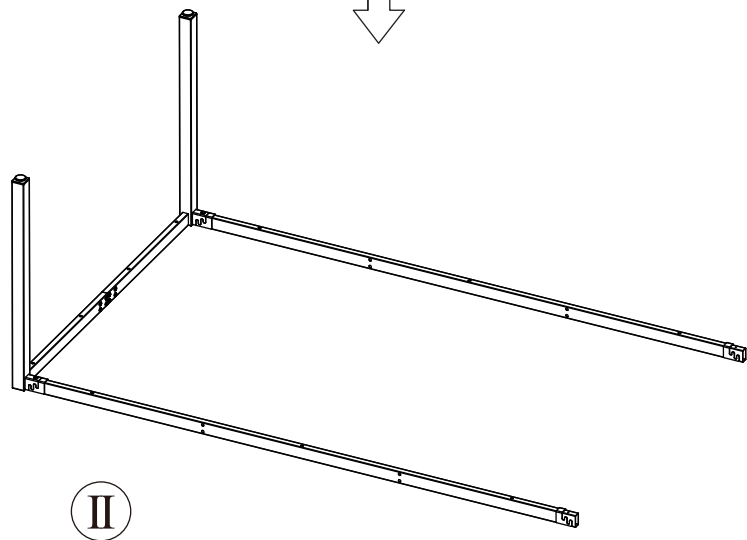
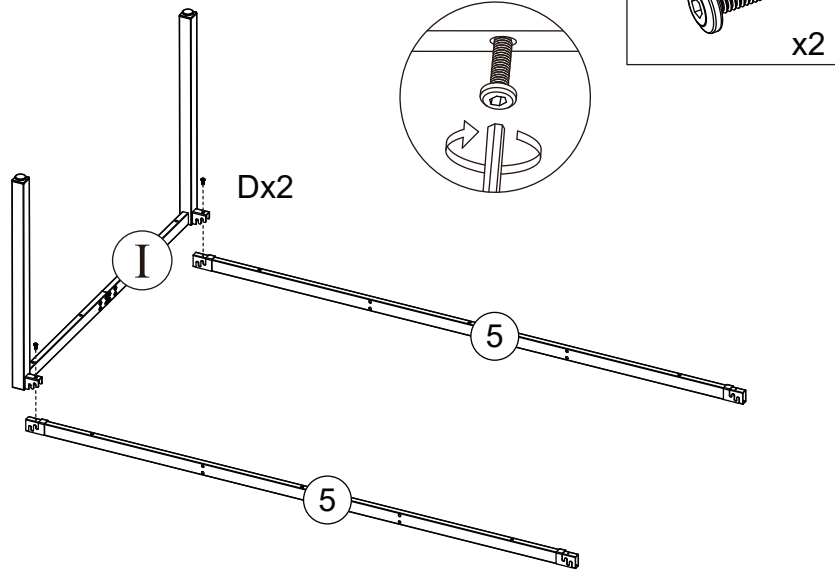

04

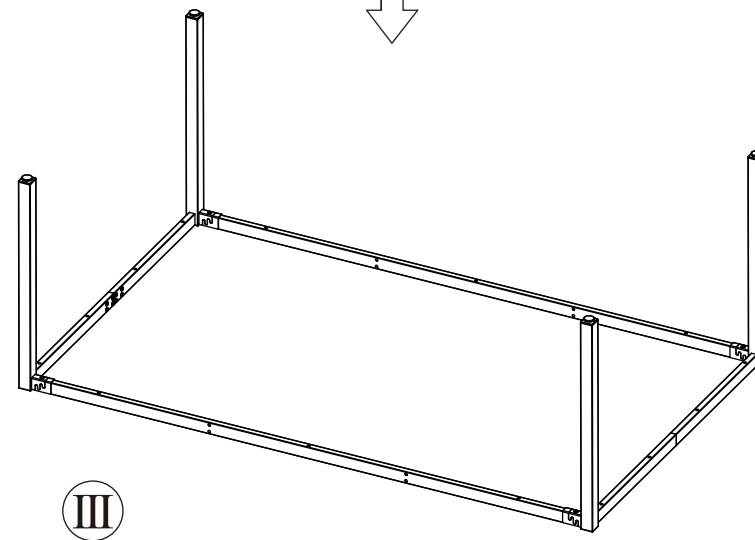
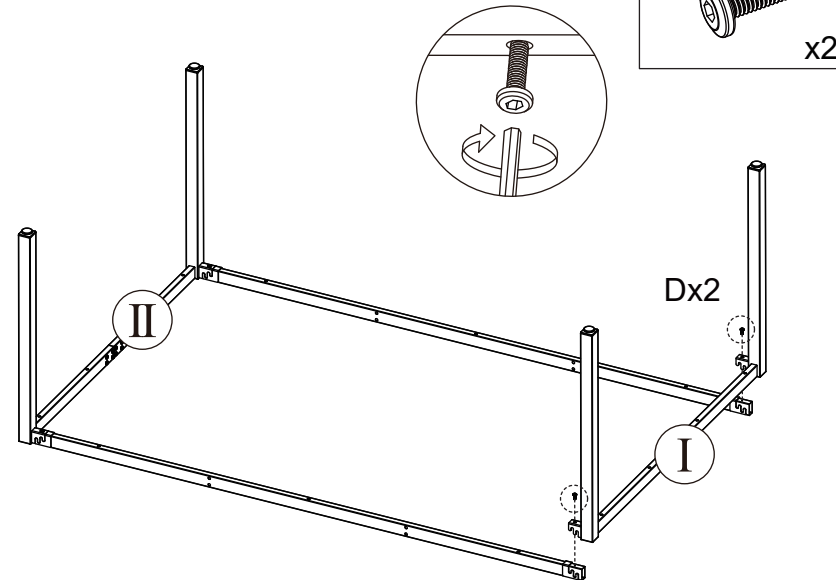

05

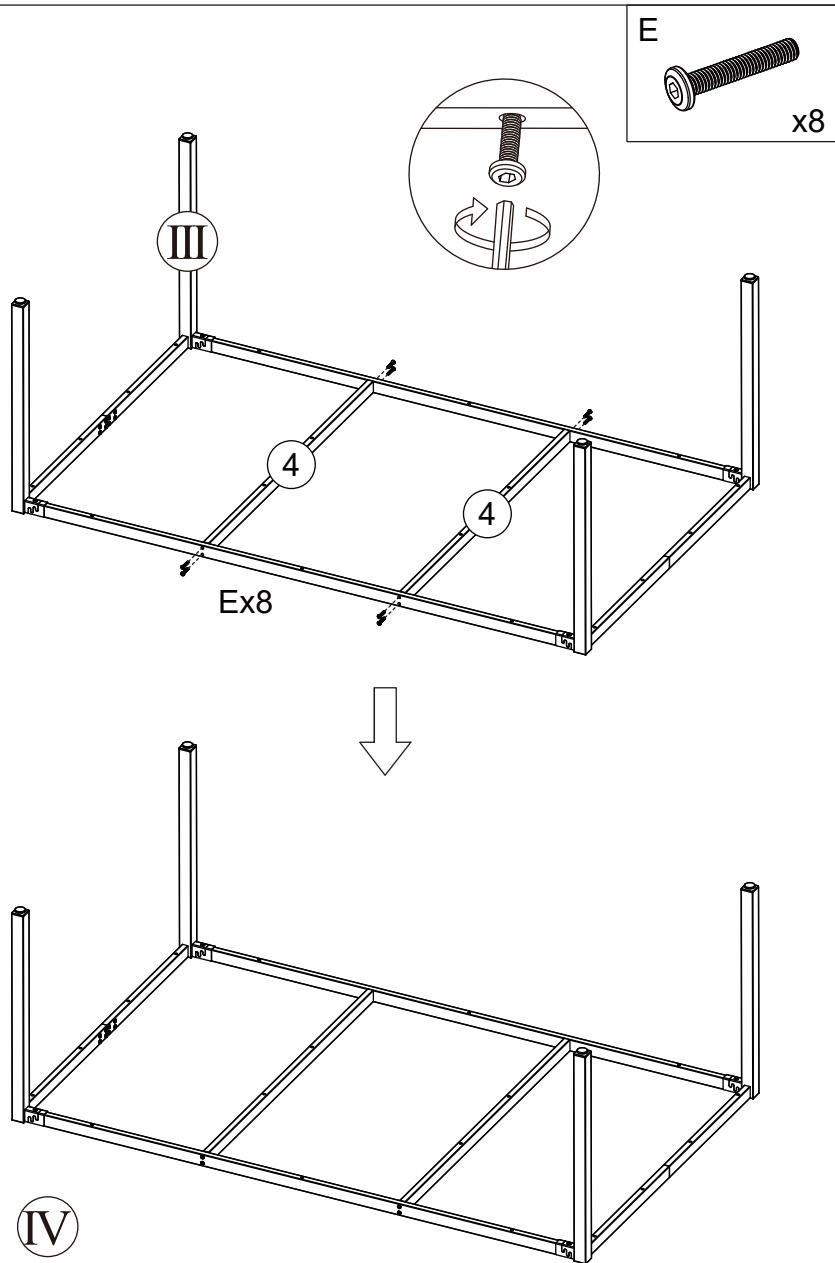

06

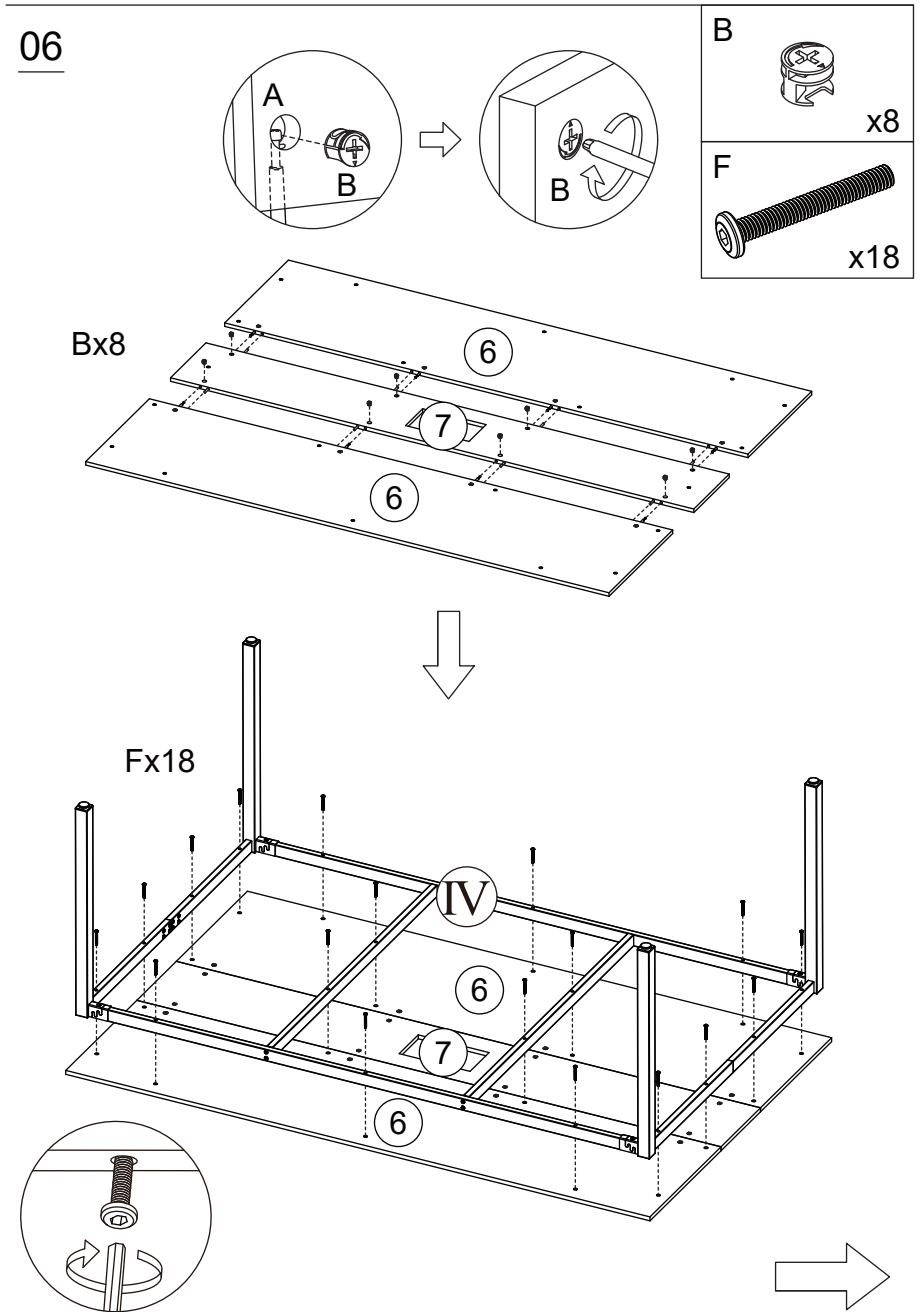

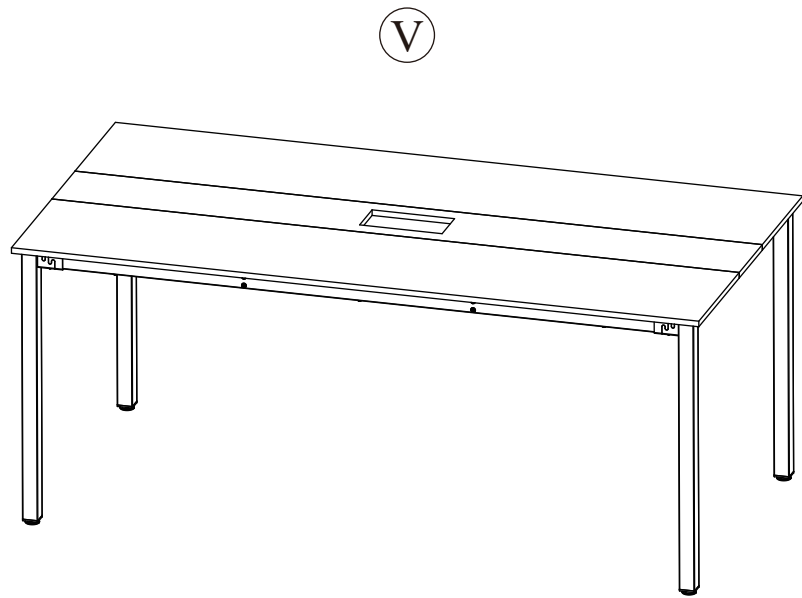

07

