

USE AND CARE GUIDE

20" VANITY WITH CERAMIC TOP

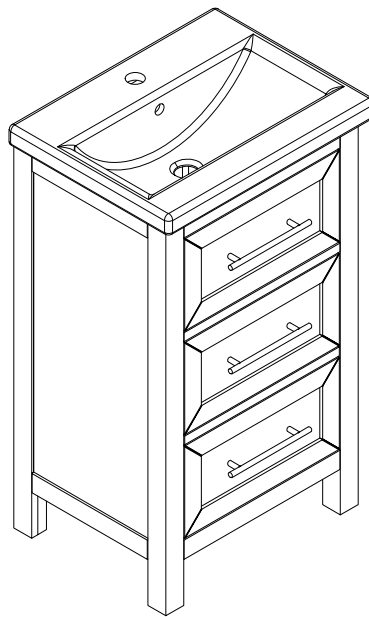

Questions, problems, missing parts?
Before returning, contact us on:

THANK YOU

*We appreciate the trust and confidence you have placed through the purchase of this Vanity.
Visit us online to see our full line of products available for your home improvement needs.*

TABLE OF CONTENTS

Safety Information.....	2
Care and Maintenance.....	3
Specification.....	4
Replacement Parts List.....	5
Package Contents.....	6
Pre-assembly	6
Assembly.....	7
Warranty.....	12

SAFETY INFORMATION

DANGER:

- Please read and understand this entire manual before attempting to assemble, operate, or install the product.
- Keep small parts away from children during assembly.
- Failure to follow warning and cautions could result in serious injury.
- Product is designed to hold 90 lbs. Exceeding this limit may damage the product or cause injury to the user.

WARNING:

- Unpacking requires two adults and several steps are more easily handled with two adults.
- This product should only be used on flat, level surface.
- Do not over tighten connectors (screws, bolts, etc.). Overtightening can lead to product damage.
- Small parts may present choking hazard prior to assembly.
- Do not stand, step, or climb on unit.
- DON'T use harsh bathroom cleaners or grout cleaners on any natural stone.

CARE AND MAINTENANCE:

- USE preventative cleaning measures to keep your stone pristine.
- USE sealers according to the product specific directions.
- Blot spills quickly, and wash with mild soap and warm water.
- Stone countertops (Granite, Marble, etc.) are surprisingly resilient to stains and scratches. However, as a preventative measure, any spills on the stone surfaces should be wiped up within a reasonable amount of time. Don't let liquid sit on the stone overnight. Stones are most prone to staining by oil and acid, so be sure to blot these spills up as soon as they happen. Follow up by cleaning the stone with a mild non-abrasive soap and water.
- Be sure to check all packing materials carefully for small parts that may have come loose inside the carton during shipment. If parts are missing, contact *us* to obtain any missing parts.

Using abrasive cleansers will damage the surface.

- Dust the vanity regularly with a soft, non-lint producing cloth or household dusting product.
- Make sure to dry the wood immediately with a soft cloth or towel.
- You can clean the vanity with a gentle, non-abrasive household cleaner.
- The stone top can be cleaned using standard marble cleaning agents available at your local supplier.
- Tips for using touch-up pen (FF): For scratches, stroke in direction of scratch; for worn areas, stroke in direction of wood grain. Rub off excess colorant promptly with a soft cloth.

IMPORTANT:

- Shade variations and patterns are an inherent characteristic of stone (e.g. granite, marble, engineered stone). Stone tops will vary from product to product. Use caution placing items such as soap or any fragranced material on the stone surface. Use a soap dish, coaster or similar item to protect the surface if placing any soap or fragranced products on the stone.
- If soap or fragranced products come in contact with the stone top, rinse the surface with water and dry using a soft non-abrasive cloth.
- WARNING:** Must use cleaning agents safe for stone. Check your cleaning agents use restrictions before using on any stone. Damage to the stone may result. Vanity manufacturer not responsible for damage caused by improper cleaning agents or soaps used. Warranty will not cover damage caused by the use of improper soaps or cleaning agents.
- DO NOT** use products to clean the stone top that contain acetone, lemon, vinegar or other acids as these may cause damage to the stone surface.
- Periodically reseal the stone top using an appropriate stone sealer available from your local home store. Follow the manufacturer's directions on how to apply.

SPECIFICATION

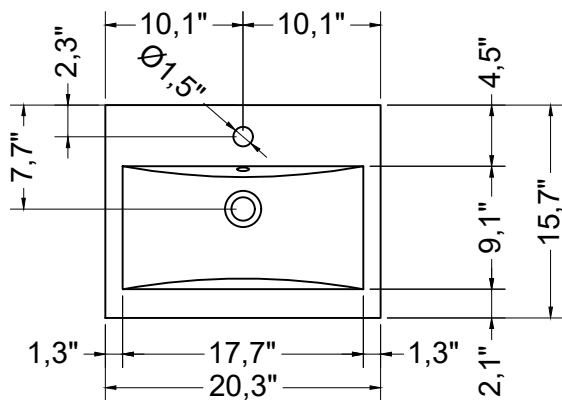

TOP VIEW

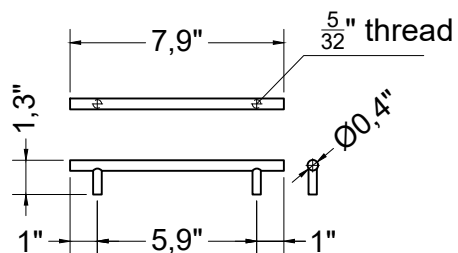

HANDLE

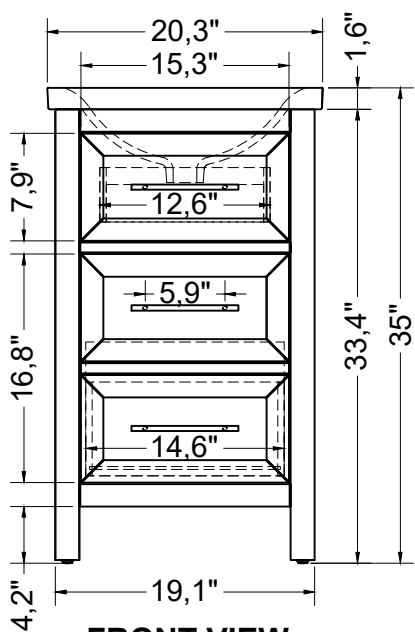

FRONT VIEW

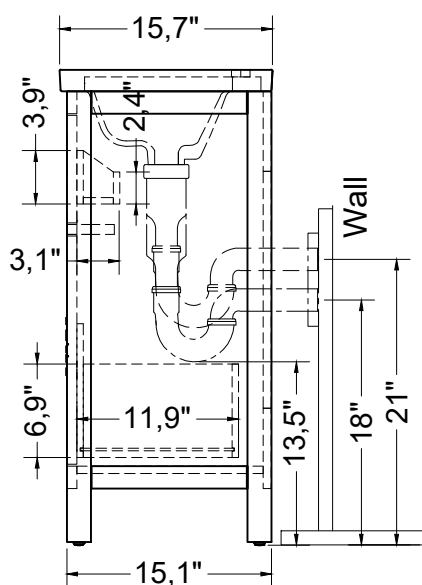

SIDE VIEW

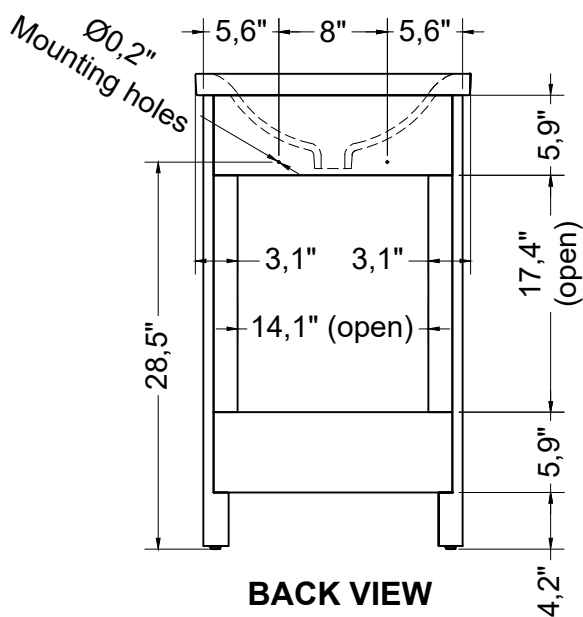

BACK VIEW

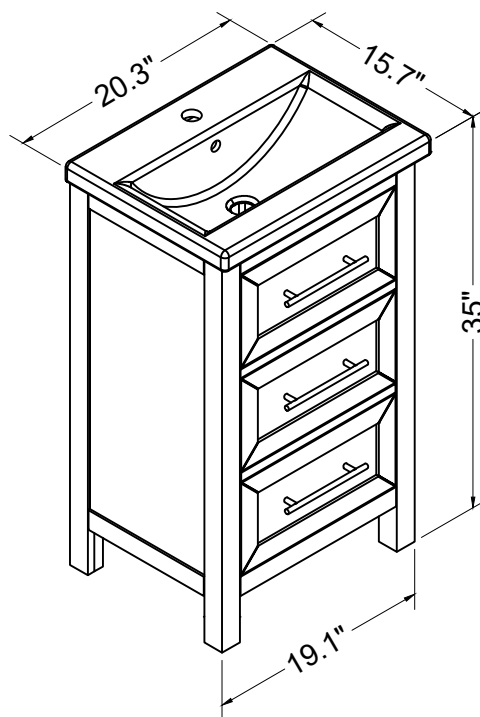

REPLACEMENT PARTS LIST

For replacement parts, please contact customer service at info@tjamerican.com.

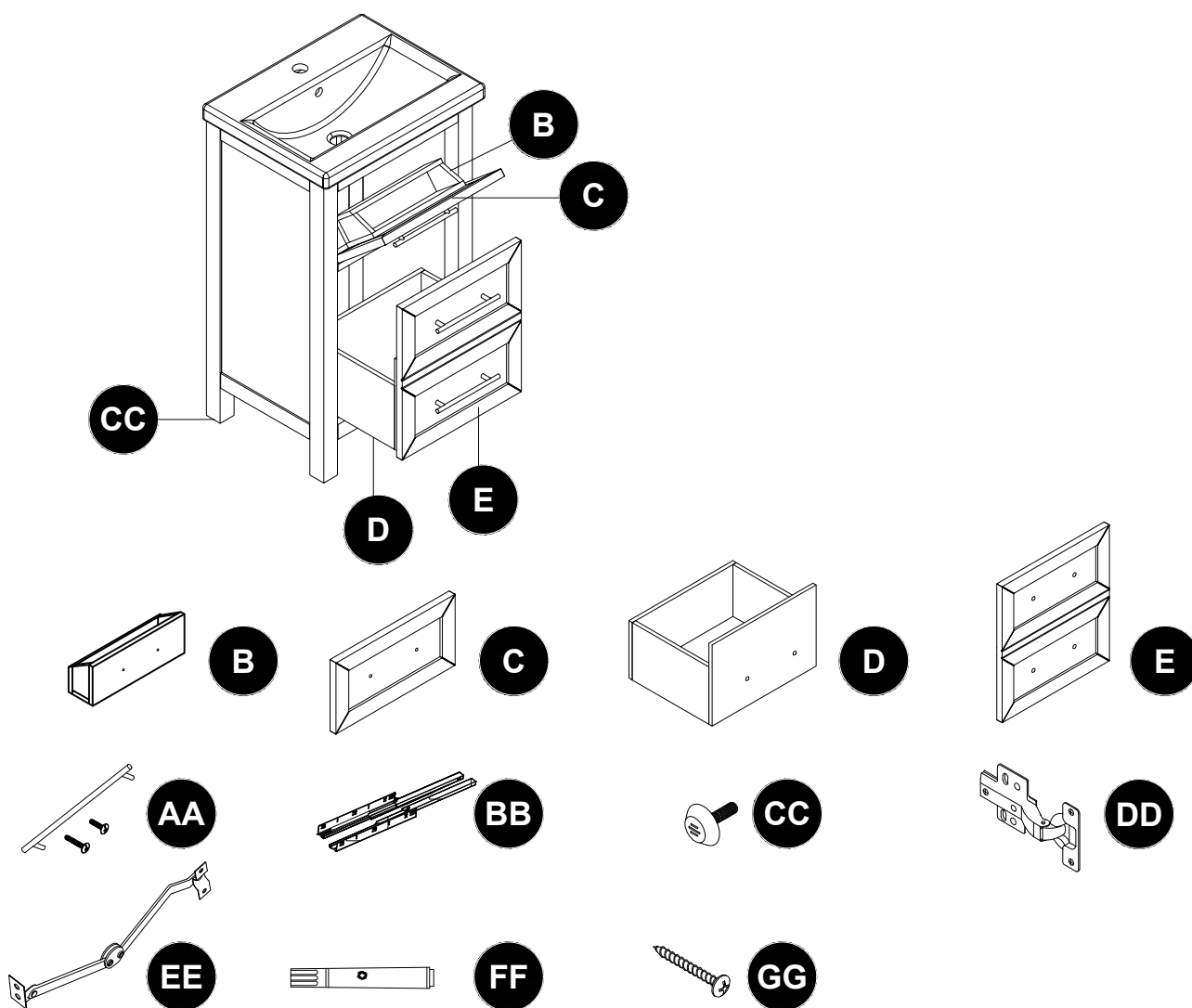

PART	DESCRIPTION	QUANTITY	REMARK
B	Flip Box	1	WH / GR / BLU
C	Flip Drawer Front	1	WH / GR / BLU
D	Bottom Drawer Box	1	WH / GR / BLU
E	Bottom Drawer Front	1	WH / GR / BLU
AA	Handle With Bolt	3	
BB	Undermount Glide	1	
CC	Leveler	4	
DD	European Hinge	2	
EE	Right Flap Hinge	1	
FF1	Touch Up Pen (White)	1	WH
FF2	Touch Up Pen (Grey)	1	GR
FF3	Touch Up Pen (Navy Blue)	1	BLU
GG	Screw	2	



The vanity has 3 finishes: WH: White, GR: Grey, BLU: Navy Blue.
Replacement parts will be separated by color in the "Remark" column

PACKAGE CONTENTS

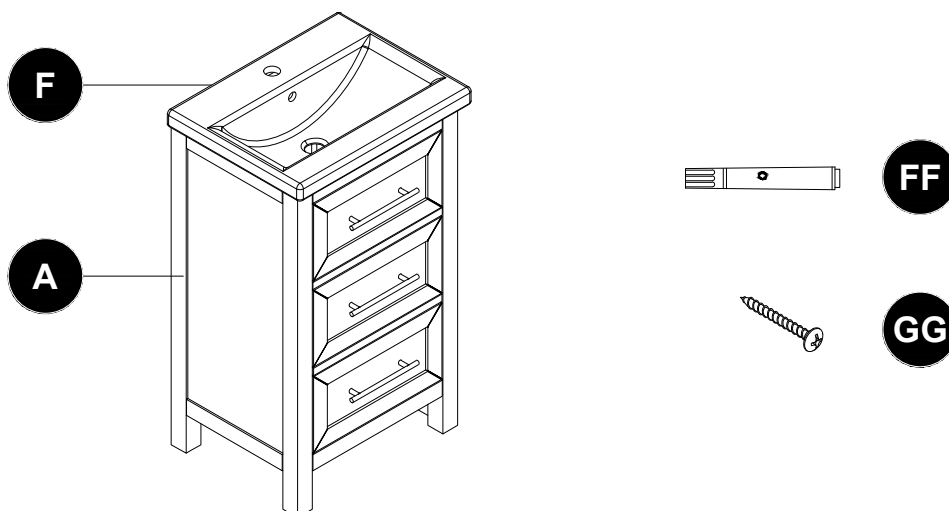

PART	DESCRIPTION	QUANTITY	REMARK
A	Vanity	1	WH / GR / BLU
F	Vanity Top	1	
FF1	Touch Up Pen (White)	1	WH
FF2	Touch Up Pen (Grey)	1	GR
FF3	Touch Up Pen (Navy Blue)	1	BLU
GG	Screw	2	

PRE-ASSEMBLY

PLANNING ASSEMBLY

Estimated Installation Time: 20-30 minutes

Number of people required: Two adults and several steps are more easily handled with two adults.

Check the vanity for damage before installation. If any part of the vanity is missing or damaged, contact the Customer Service Team.

Ensure that the vanity location is accessible to water supply and drain lines. It is recommended that you rough-in the water lines and drain before installing the vanity.



A drain pipe and trap are not included with this vanity.

ASSEMBLY

1. Removing the protective sheet.

- Lift off the vanity top and set it aside.
- Remove the protective sheet.

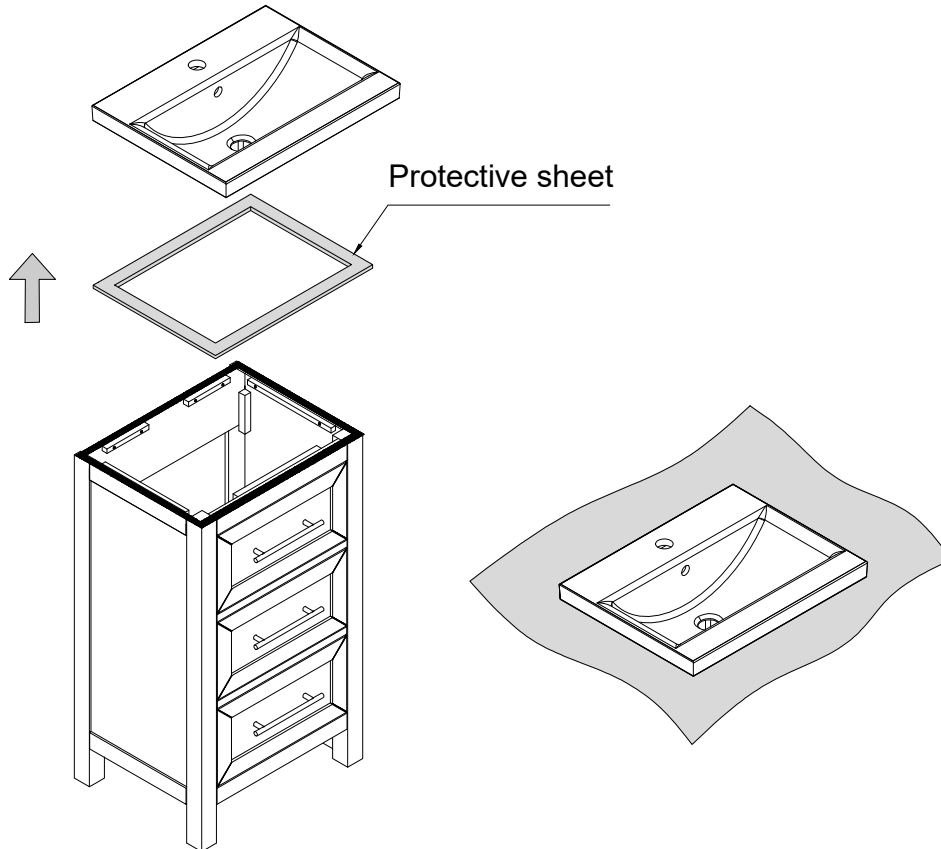

ASSEMBLY

2. Installing vanity to the wall.



Note: Clean area where the vanity (A) will be permanently located prior to beginning installation, ensuring the vanity (A) will not interfere with any water supply and drain lines once mounted.

- With two people, carefully place the vanity (A) against the wall in its final location. Place a level on the unit in both directions, across the front and on both sides to properly adjust the levelers on the unit. Use preassembled levelers on the feet of the vanity to level the item. Twisting the levelers counterclockwise will increase the height of the vanity (A), twisting them clockwise will decrease it.
- From the pre-drilled hole in the vanity, find and mark the locations on the wall. If possible, secure the vanity (A) to at least one wall stud for increasing stability.
- Use screws (GG) (included) to secure the vanity (A) to the wall stud or your appropriate mounting hardware (not included) to secure the vanity (A) to the wall at the no wall stud position.



WARNING:

- Vanity (A) SHOULD be secured to at least one wall stud.

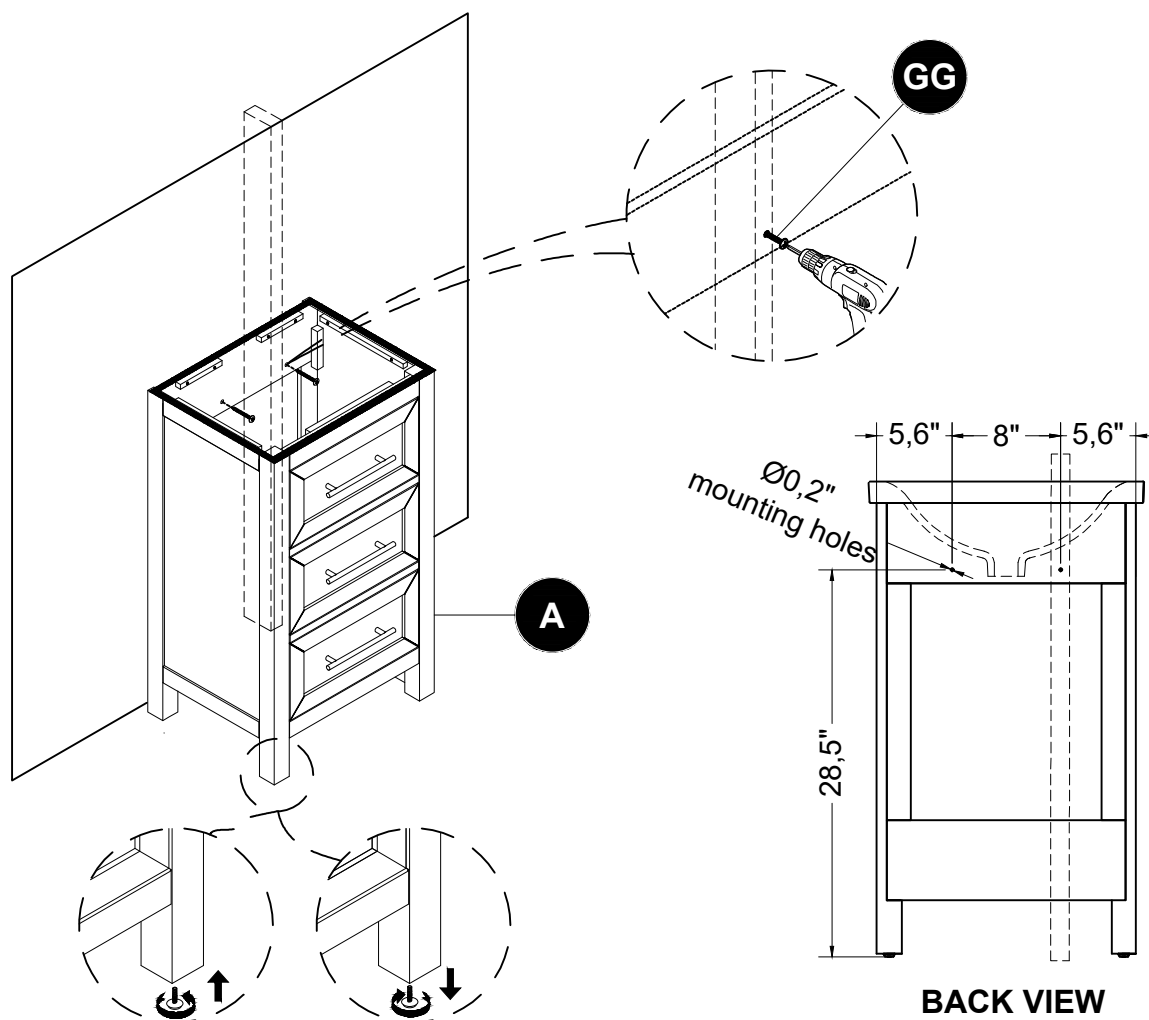

ASSEMBLY

3. Assembling the vanity top.

- Place the vanity top back in position. For everyday use the vanity top can be placed directly, but we recommend securing it with silicone as described below for added stability.
- Remove the foam from the areas where silicone (not provided) will be applied.
- Place the vanity top so it is centered left to right and sits flush against the back.

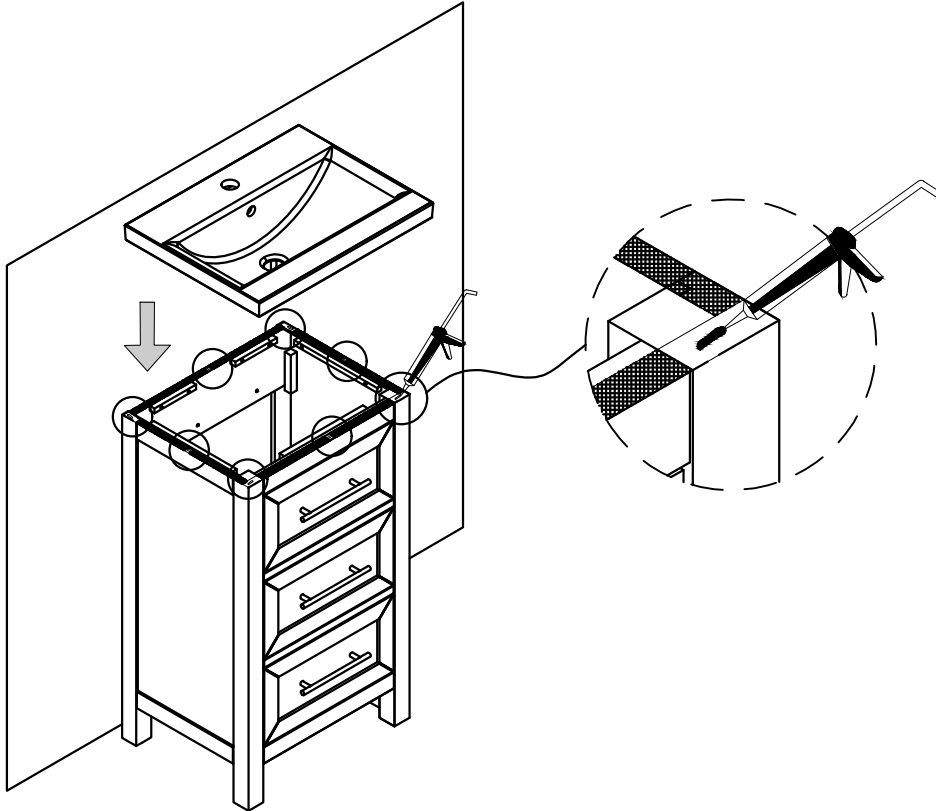

- Apply silicone all around the joint between the vanity body and the top.

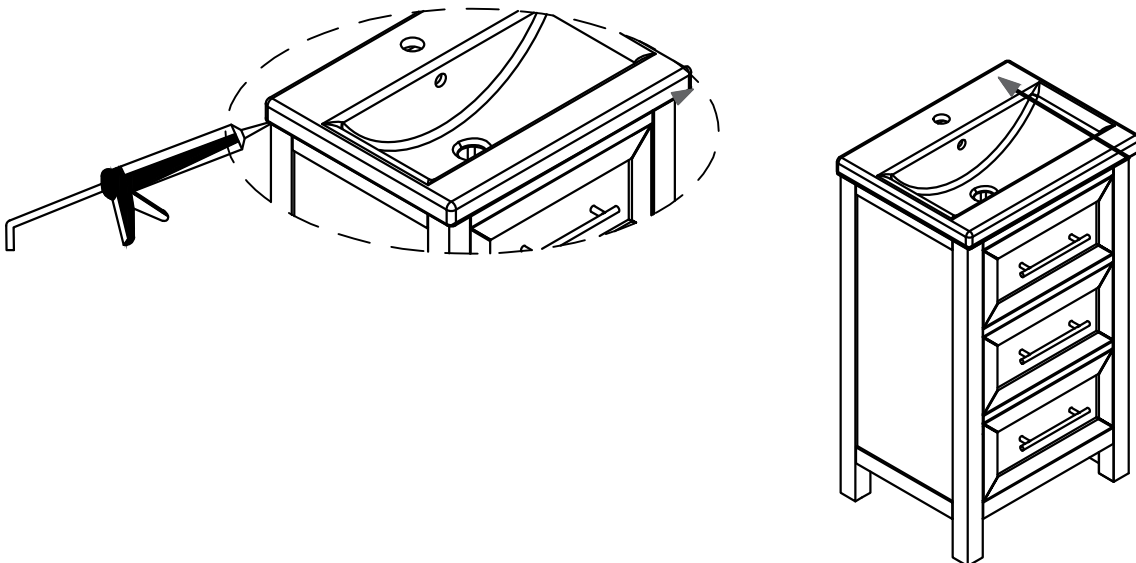

ASSEMBLY

4. Removing the bottom drawer (optional).

- Fully extend drawers, and locate plastic levers on the metal glide tracks at left and right sides of the drawer box.
- Push on plastic levers on both sides at the same time to disengage the drawer box from the glides.
- Gently lift the drawer up to remove it from the glide tracks.

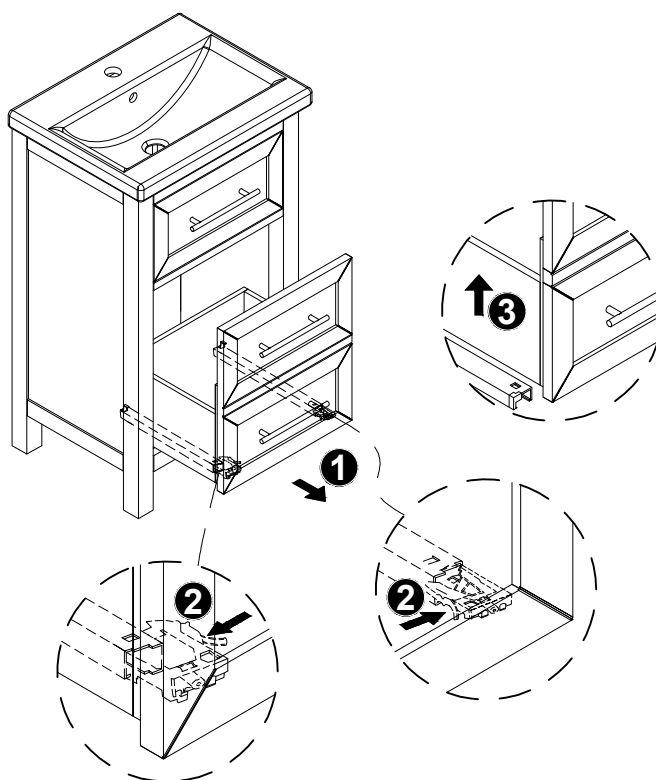

ASSEMBLY

5. Re-installing the bottom drawer (optional).

- Fully extend the metal glide tracks.
- Gently lower and slide the drawer box into the rear glide catch.
- Lower the drawer box down to completely rest on extended glides and push plastic levers to lock the drawer box in place.



CAUTION: DO NOT force drawer or damage to glide may occur. If drawer does not slide in with ease, remove and try again from the start.

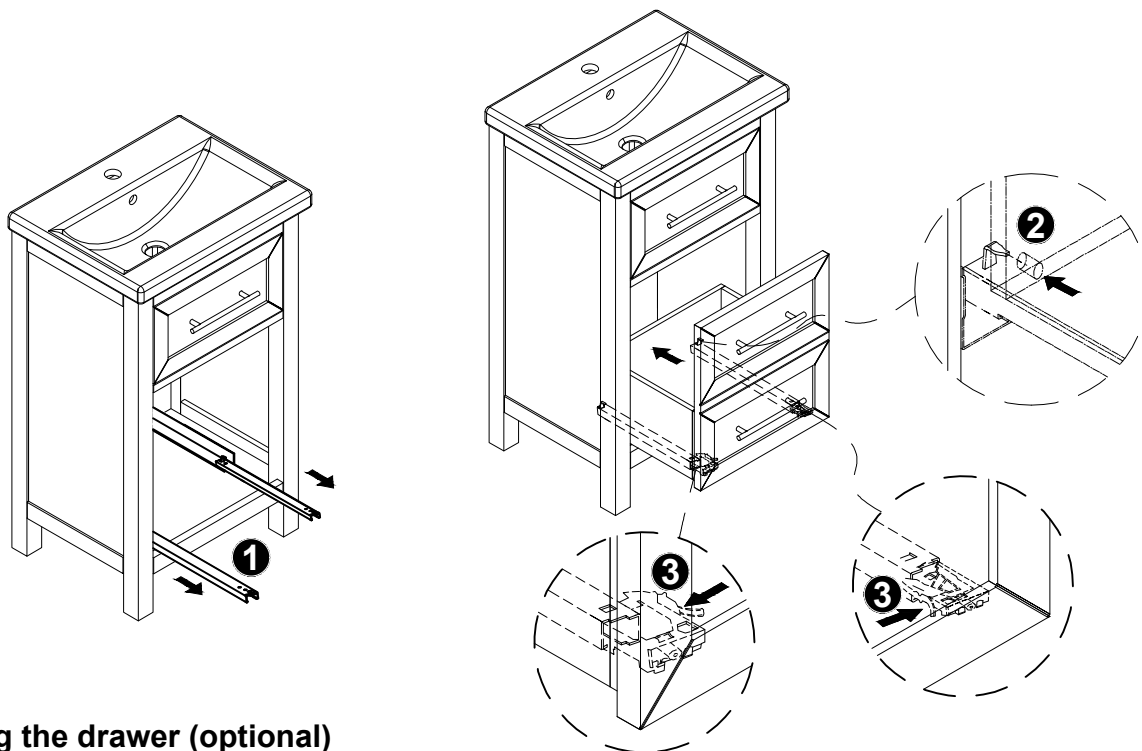

6. Adjusting the drawer (optional)

- Spin the adjustment wheel to the left to raise the drawer box or spin the adjustment wheel to the right to lower the drawer box. You can adjust the left and right side height independently in order to find the drawer best alignment position.

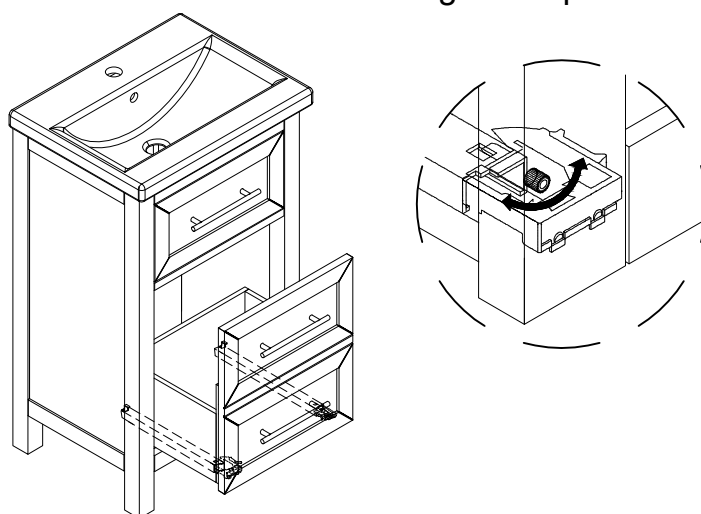

Note: Assembly is now complete. Install desired faucet and drain assemblies (neither included) per the manufacturers' instructions to complete the installation.

WARRANTY

LIMITED LIFETIME WARRANTY

WHAT IS COVERED

Our products are manufactured to superior quality standards and workmanship, and are backed by our limited lifetime warranty. Our products are warranted to the original consumer purchaser to be free of defects in materials or workmanship. We will replace FREE OF CHARGE any product or part that proves defective. Simply return the product or part to any retail location to receive the replacement item. Proof of purchase (original sales receipt) from the original consumer purchaser must be made available for all warranty claims.

WHAT IS NOT COVERED

This warranty excludes incidental or consequential damages and failures due to misuse, abuse, or normal wear and tear. Some states and provinces do not allow the exclusion or limitation of incidental or consequential damages, so the above limitations may not apply to you. This warranty gives you specific legal rights, and you may also have other rights that vary from state to state and province to province. Please see a store or contact us for more details.