

ITEM NO.	PART NUMBER	DESCRIPTION	QTY.
1	PIPE-FL12-3	1/2" FLANGE	1
2	PIPE-TEE-12	1/2" TEE	1
3	PIPE-CAP-12	1/2" CAP	2
4	PIPE-NIP12-2.5	1/2" 2 1/2" NIP	1
5	PIPE-NIP12-5	1/2" 5" NIP	2
6	WOOD SCREW-12	#12 WOOD SCREW	4

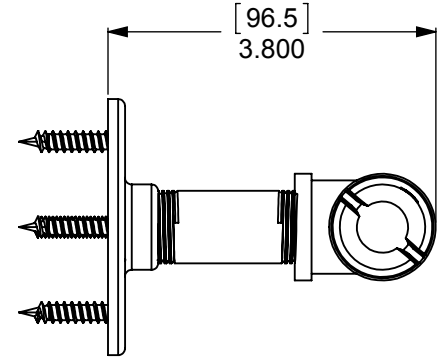

UNLESS OTHERWISE STATED

.X	±.3mm
.XX	±.15mm
.XXX	±.008mm

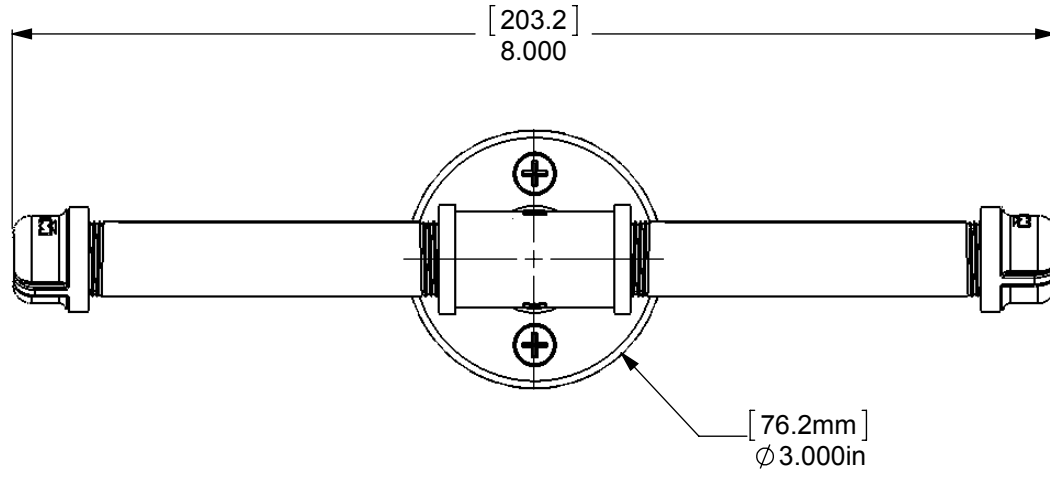
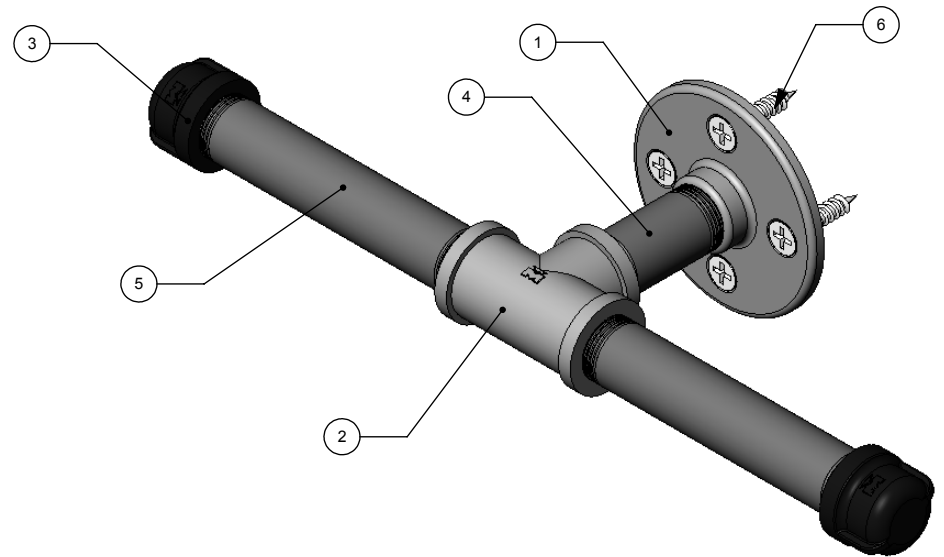
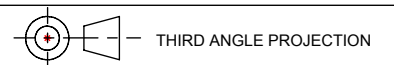

MATERIAL:	BRASS
DESCRIPTION:	Double Roll Toilet Paper Holder