

ASSEMBLY INSTRUCTIONS



OFFICE DESK

ASSEMBLY INSTRUCTIONS

ASSEMBLY TIPS:

1. Remove hardware from box and sort by size.
2. Please check to see that all hardware and parts are present prior to start of assembly.
3. Please follow attached instructions in the same sequence as numbered to assure fast & easy assembly.



WARNING!

1. Don't attempt to repair or modify parts that are broken or defective. Please contact the store immediately.
2. This product is for home use only and not intended for commercial establishments.



ASSEMBLY TIME

60 MINUTES

PARTS IDENTIFICATION

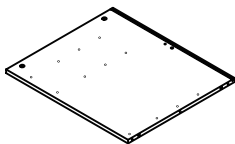
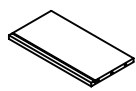
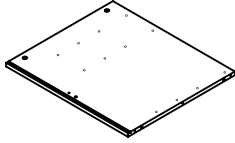
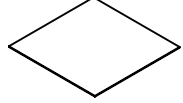
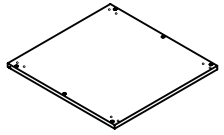
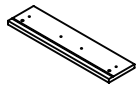
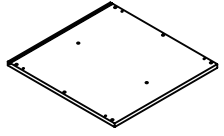
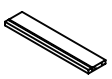
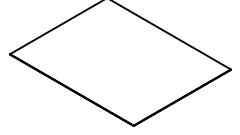
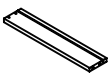
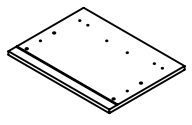
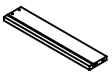
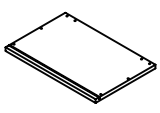
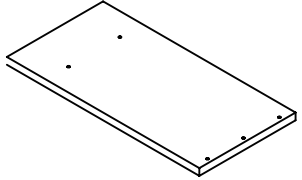
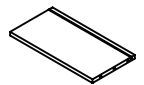
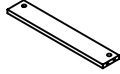
A	LEFT SIDE PANEL		1 PC	I	LARGE RIGHT DRAWER SIDE PANEL		1 PC
B	RIGHT SIDE PANEL		1 PC	J	DRAWER BOTTOM PANEL		3 PCS
C	BOTTOM PANEL		1 PC	K	SMALL DRAWER FRONT PANEL		2 PCS
D	SMALL TOP PANEL		1 PC	L	SMALL DRAWER BACK PANEL		2 PCS
E	BACK PANE		1 PC	M	SMALL LEFT DRAWER SIDE PANEL		2 PCS
F	LARGE DRAWER FRONT PANEL		1 PC	N	SMALL RIGHT DRAWER SIDE PANEL		2 PCS
G	LARGE DRAWER BACK PANEL		1 PC	O	LARGE TOP PANEL		1 PC
H	LARGE LEFT DRAWER SIDE PANEL		1 PC	P	BACK BRACE		1 PC

NOTE:

Phillips head screw driver is required in the assembly process; however, manufacturer does not provide this item.

Q LEG FRAME

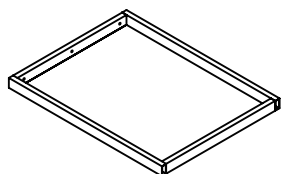

1 PC



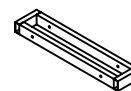











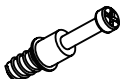

R SUPPORT

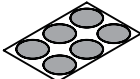

1 PC

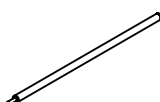
Z

HARDWARE IDENTIFICATION

NO	DESCRIPTION	FIGURE	Q'TY	NO	DESCRIPTION	FIGURE	Q'TY
1	GLUE 15g		1 PC	10	FOOT SCREW Ø 5x23mm BLK		8 PCS
2	WOODEN DOWEL Ø 8x30mm		20 PCS	11	LONG SCREW Ø 4.5x42mm SR		6 PCS
3	CAM LOCK Ø 15x12mm SR		12 PCS	12	ALLEN BOLT M6 x 35mm SR		7 PCS
4	CAM BOLT Ø 7x35.5mm SR		12 PCS	13	ALLEN WRENCH 4mm SR		1 PC
5	SCREW Ø 4.3x35mm SR		12 PCS	14	STICKER Ø 20mm		2 PCS
6	GLIDES SCREW Ø 3x12 mm SR		42 PCS	15	GLIDES L = 400mm WHT		3 SET
7	HANDLE L=120mm		3 PCS	16	IRON BAR Ø 9.5x402mm SR		2 PCS
8	HANDLE BOLT Ø 4x28mm SR		6 PCS	17	FLOOR PROTECTOR 40x20mm		2 PCS
9	FOOT 50x50x18mm		4 PCS				

Z7,Z8,Z9,Z15,Z16 not included in blister packaging.

INCORRECT
CORRECT

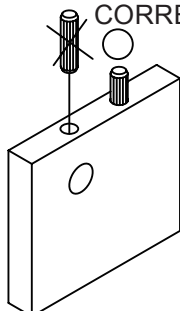

Apply glue on all wooden dowels to ensure integrity of the structure.

NOTE:

Phillips head screw driver is required in the assembly process; however, manufacturer does not provide this item.

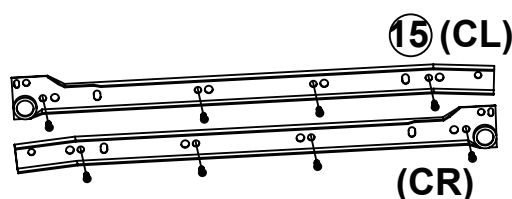

STEP 3

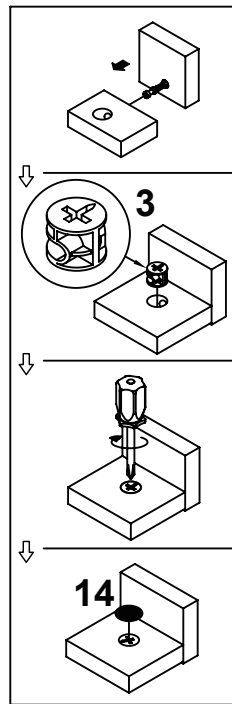
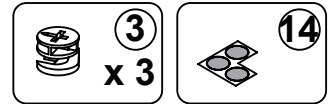
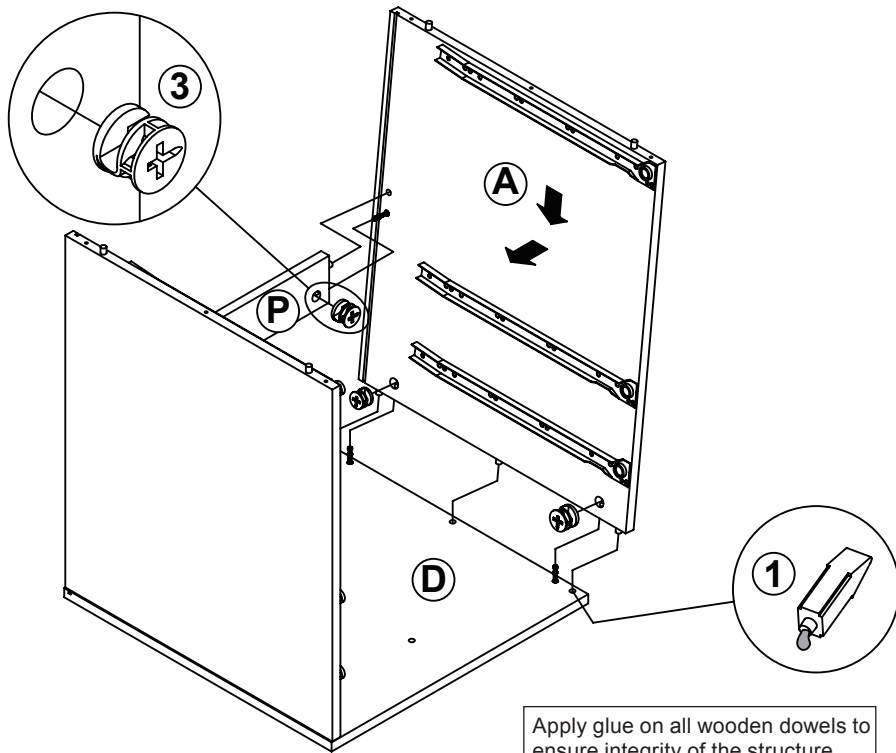

STEP 4

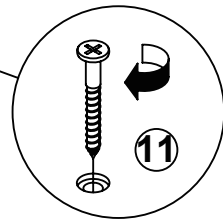
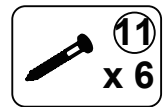
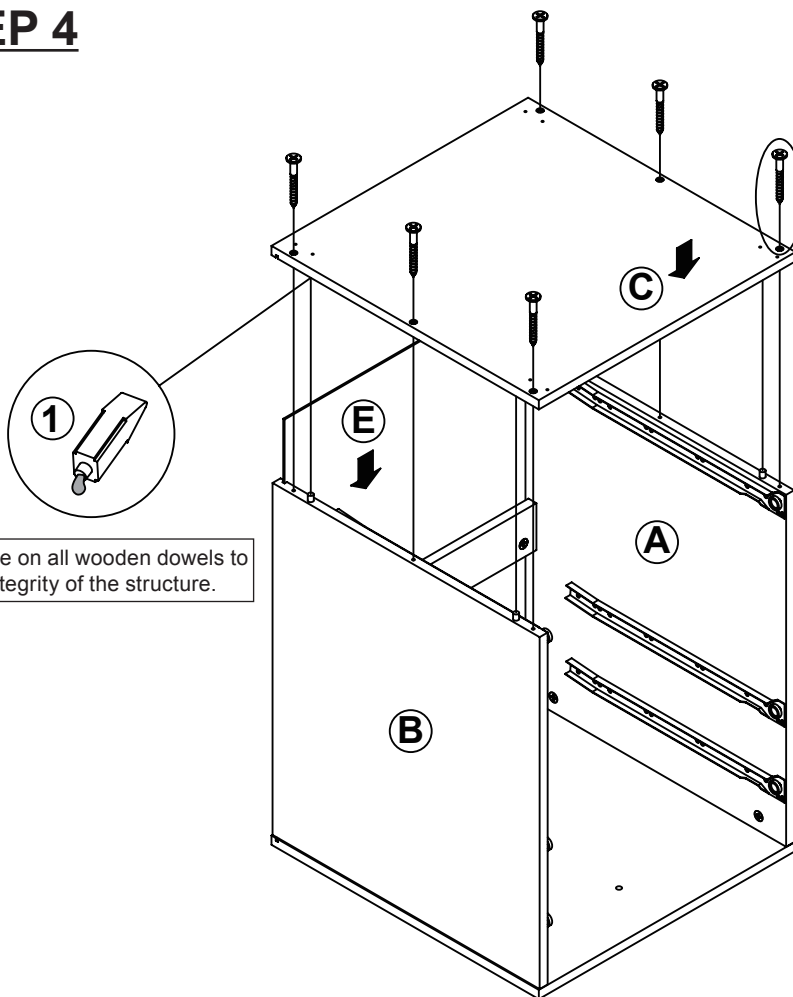

Apply glue on all wooden dowels to ensure integrity of the structure.

STEP 7

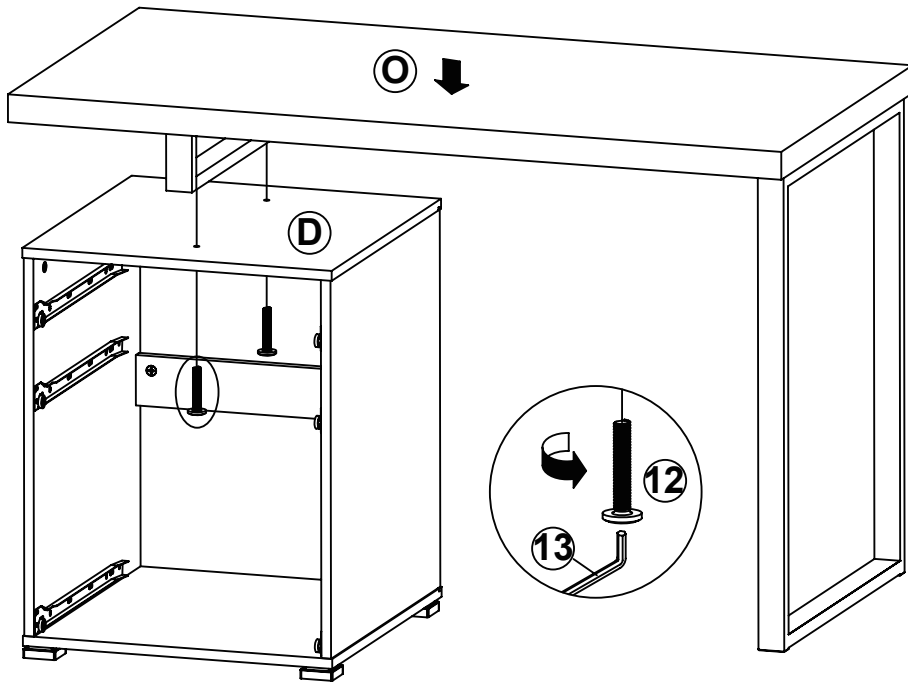
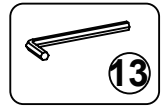
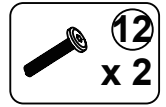

LEFT

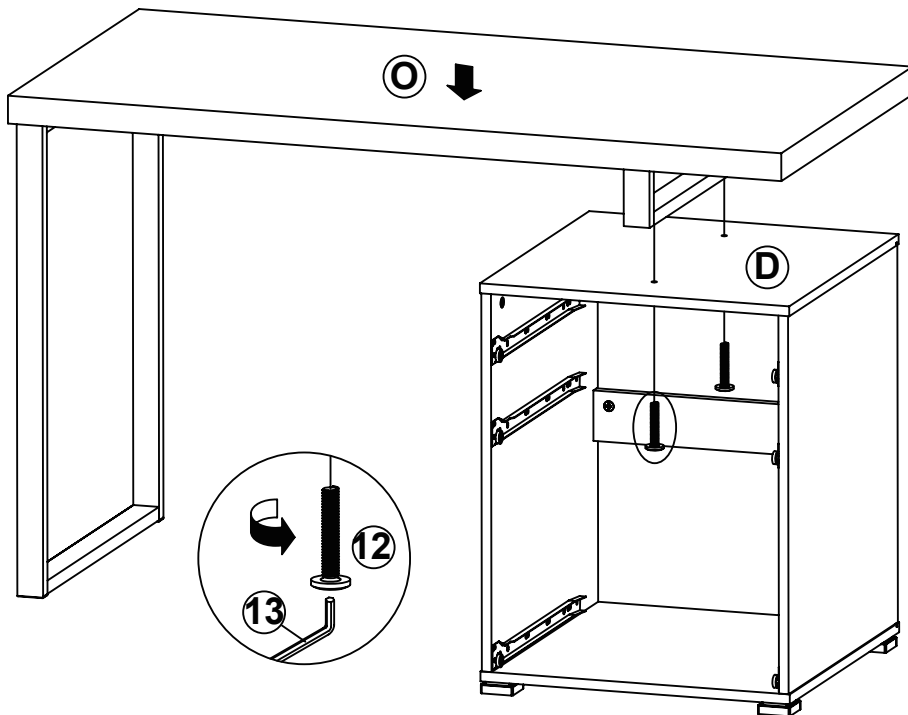

RIGHT

STEP 8-1

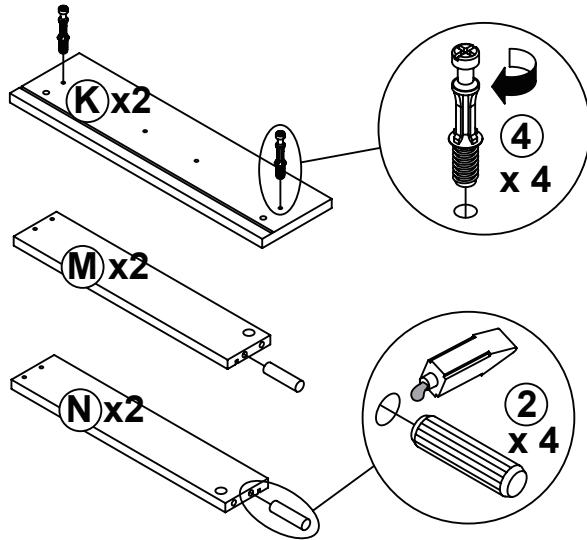

STEP 8-2

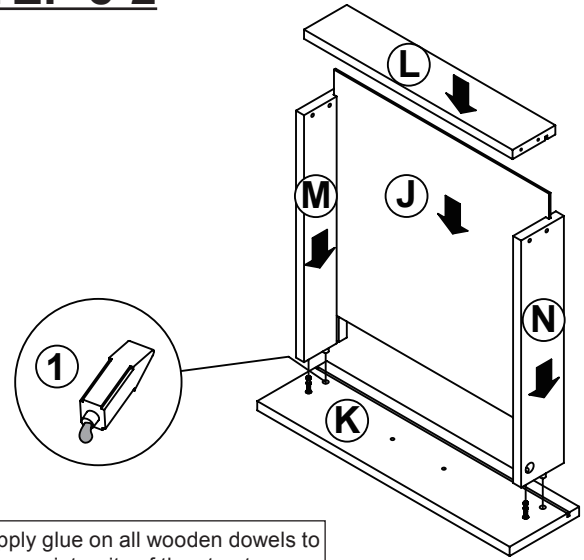

Apply glue on all wooden dowels to ensure integrity of the structure.

STEP 8-3

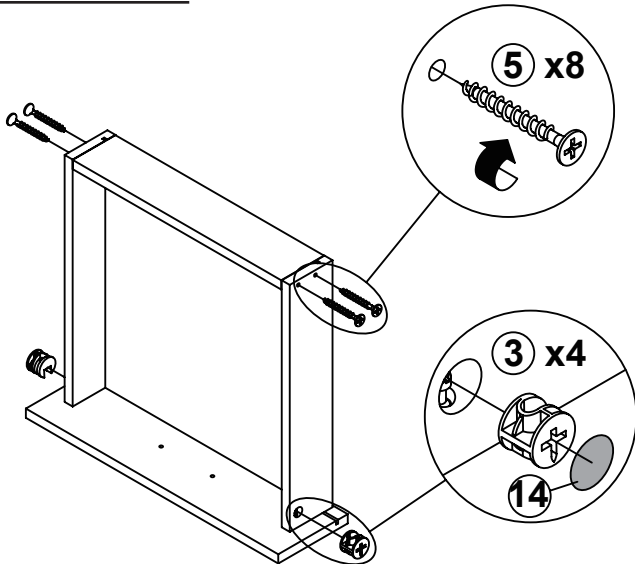

STEP 8-4

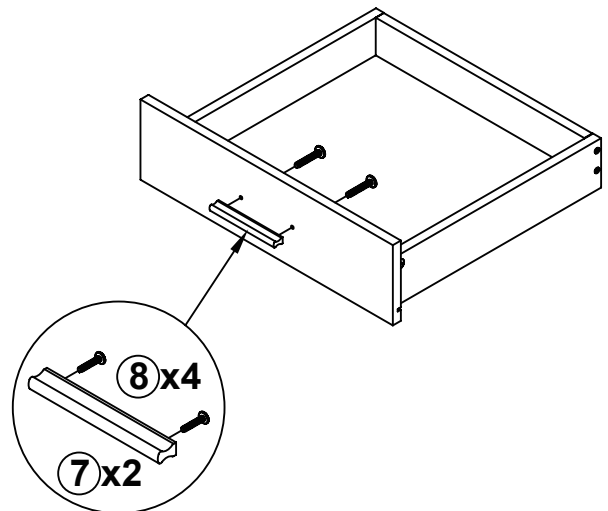

STEP 8-5

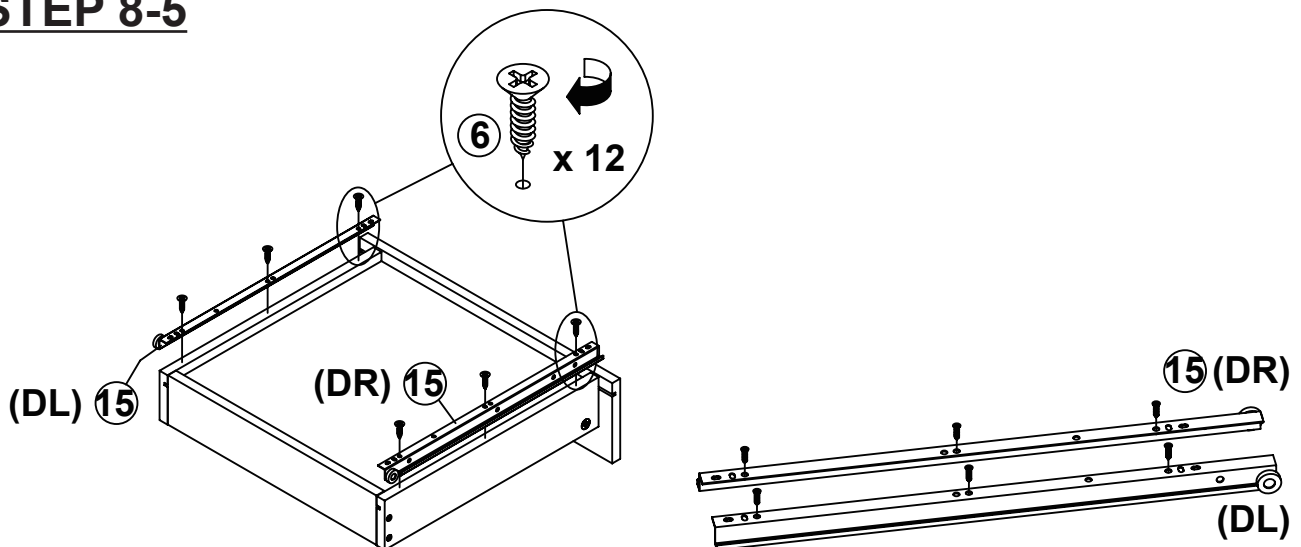

STEP 9-1

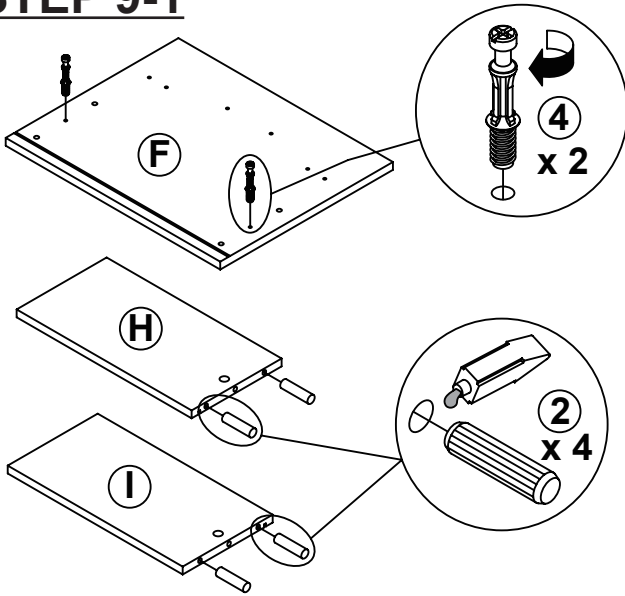

STEP 9-2

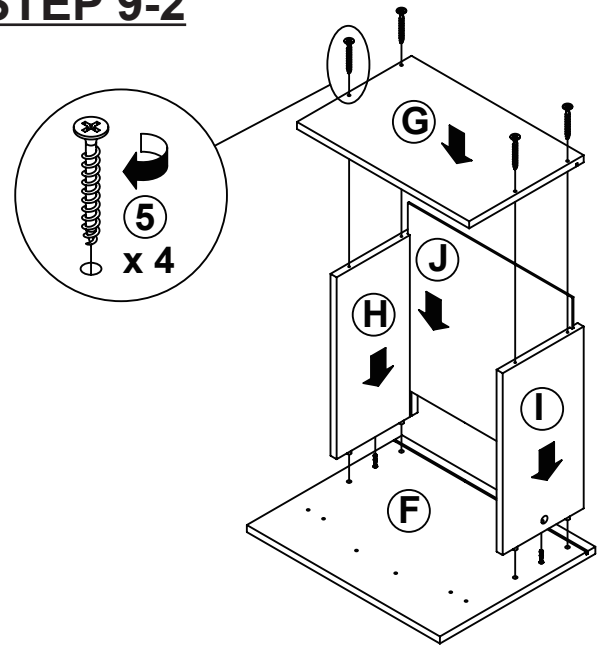

STEP 9-3

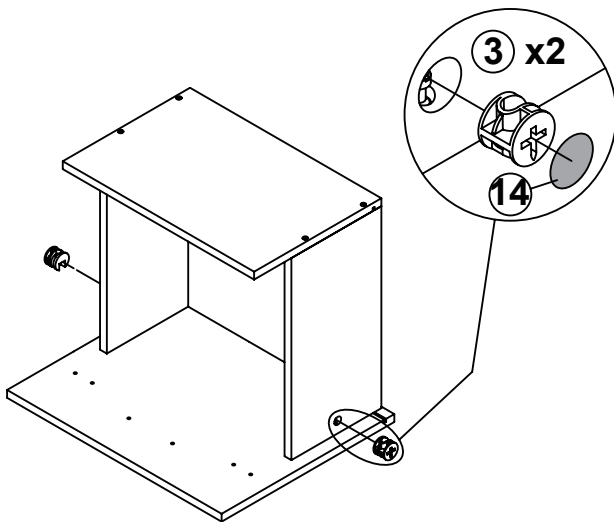

STEP 9-4

Insert rails in outside holes for large files.
Insert rails in inside holes for small files.

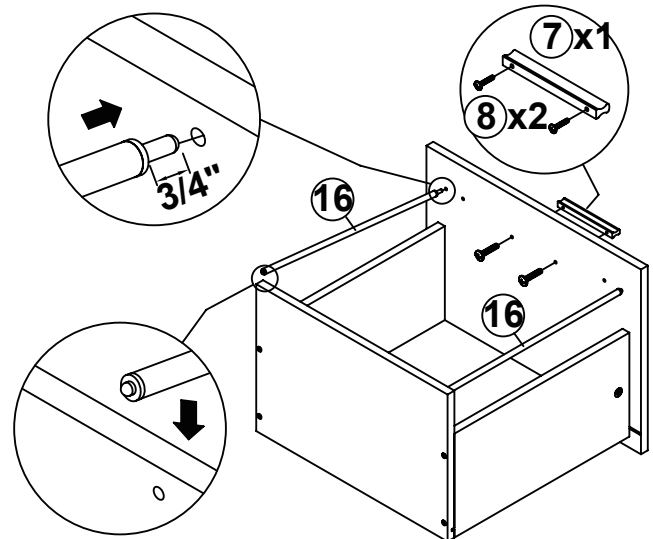

STEP 9-5

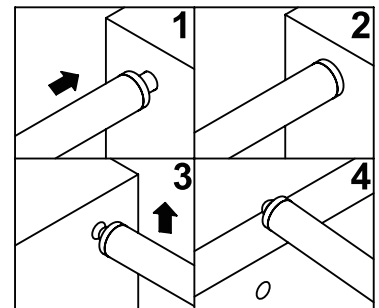
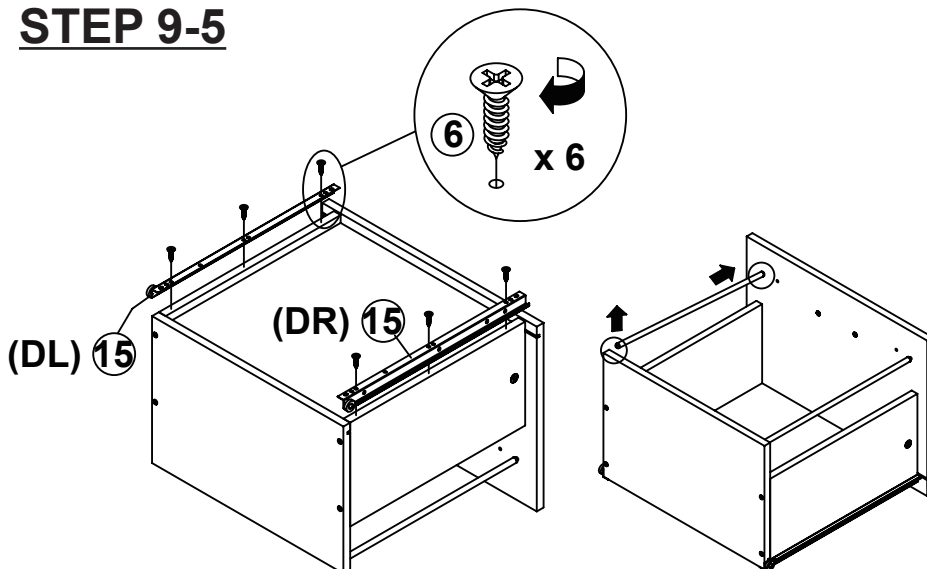

STEP 10

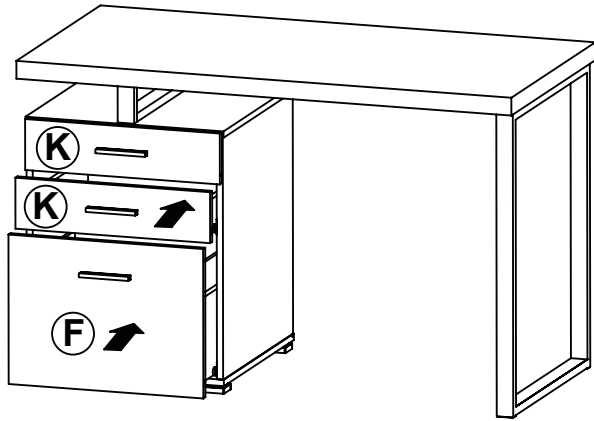

LEFT

STEP 11 COMPLETE

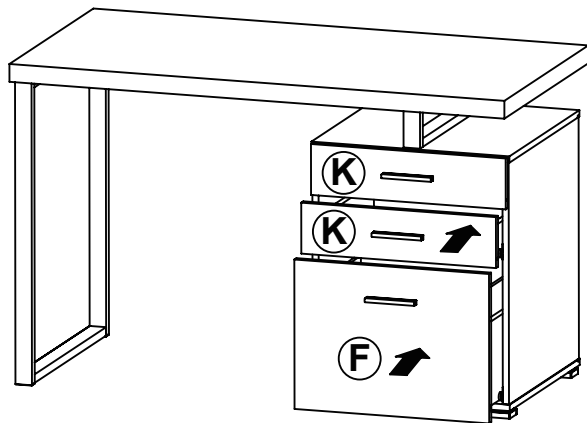
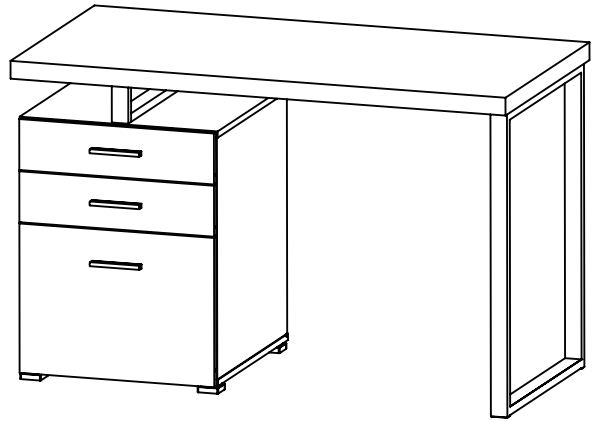

RIGHT

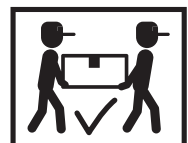
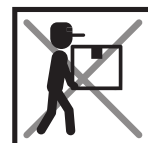
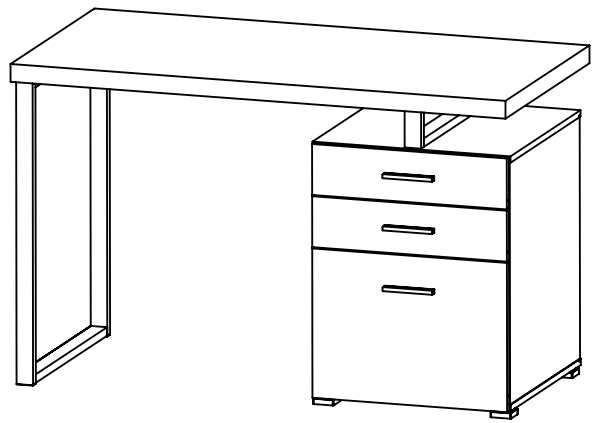

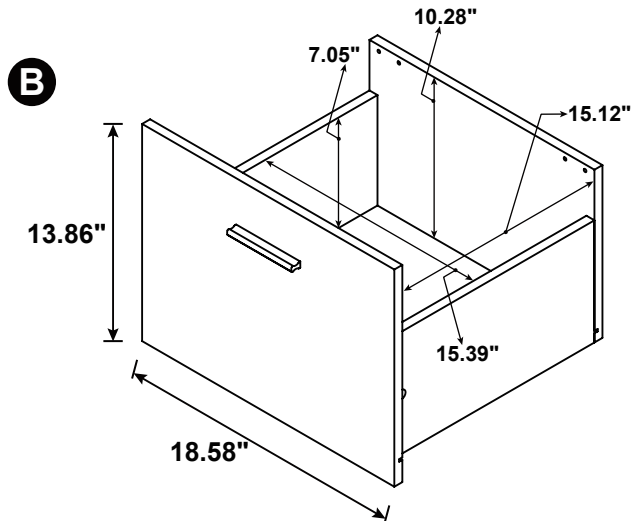
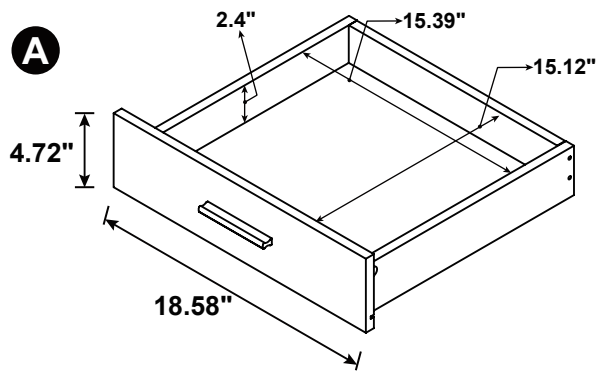
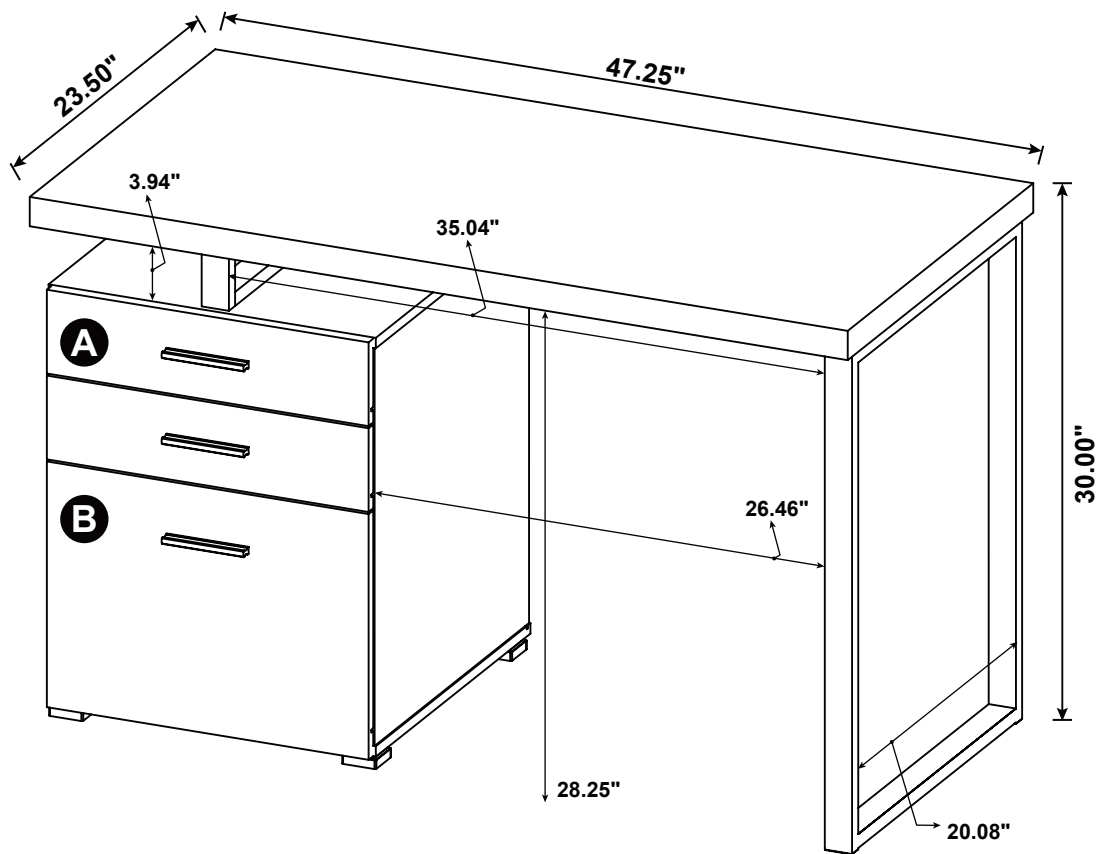

Note : Dimension tolerance $\pm 5\%$