

STEP 4

Attach Top Panel (A) and tighten it with Top Cap (3).

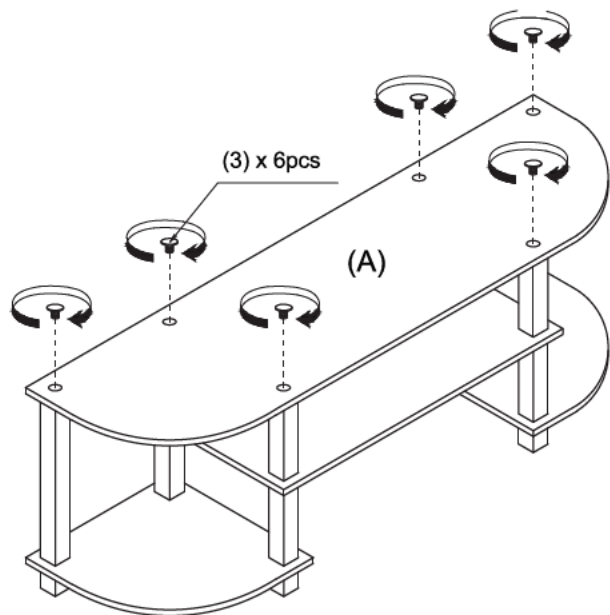

Recommended Maximum Weight

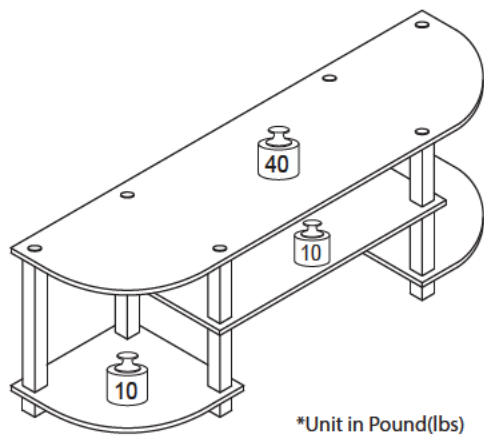

WARNING:

>This unit has been designed to support the maximum loads shown. Exceeding these load limits could cause sagging, instability, product collapse, and/or serious injury.

>DO NOT allow children to climb on unit.

>Put heavier items on lower shelves.

Assembly Instruction

00:20

Approx. 20 minutes









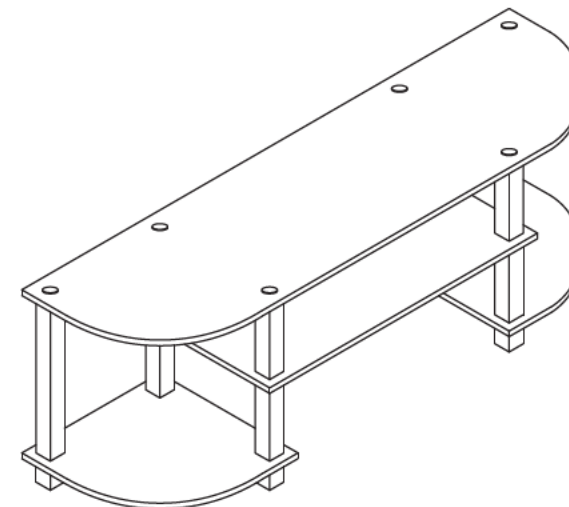

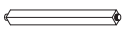
Recomm. 1 Person



No Tools Required

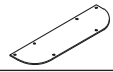

No	Hardware List	Qty
1	Square Long Pole 	2pcs
2	Square Short Pole 	8pcs
3	Top Cap 	6pcs
4	Square Leg 	6pcs

No	Parts List	Qty
A	Top Panel 	1pc
B	Shelf Panel 	1pc
C	Bottom Left Panel 	1pc
D	Bottom Right Panel 	1pc

Tips: Bottom Left Panel (C) & Bottom Right Panel (D) are same but different by woodgrain.

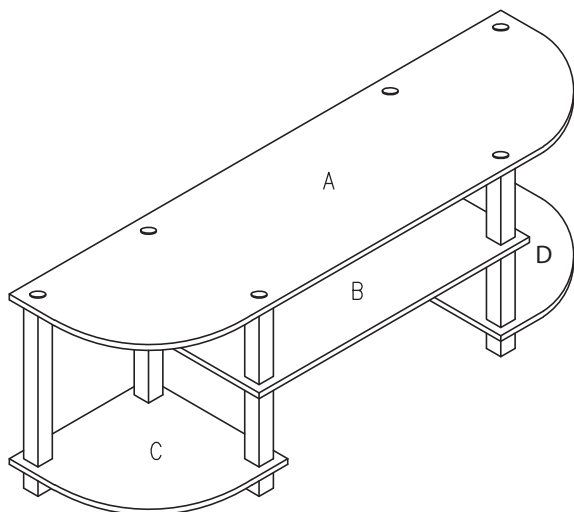

USEFUL HINTS BEFORE YOU START:

1. Read each step carefully before starting.
2. It is important that each step is performed in correct order to avoid difficulties.
3. Identify, sort and count the parts before assembly.
4. Assemble your furniture on packaging cardboard to prevent scratch or damage.
5. Clean the product with mild cleanser using soft damped cloth. Do not use harsh or abrasive cleanser.
6. Using incompatible hardware might cause damage to product.

STEP 1

Install Square Leg (4) to the bottom of Panel (C)&(D).

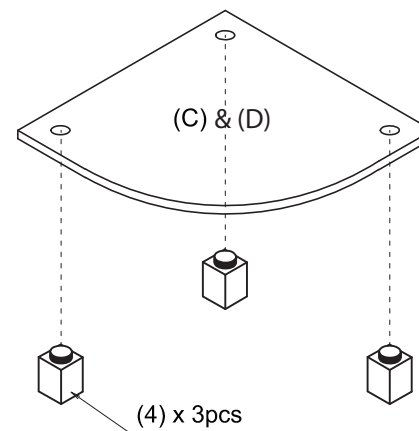

STEP 2

Tighten Long Leg (1) & Short Leg (2) on Panel (C)&(D), as shown.

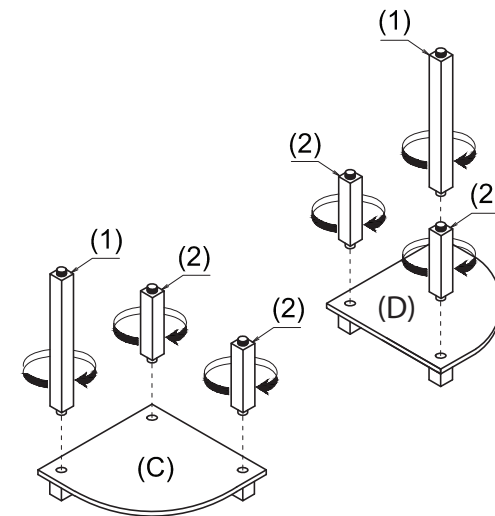

STEP 3

Attach Panel (B) and tighten with Short Pole (2).

