

ASSEMBLY INSTRUCTION

STORAGE BENCH

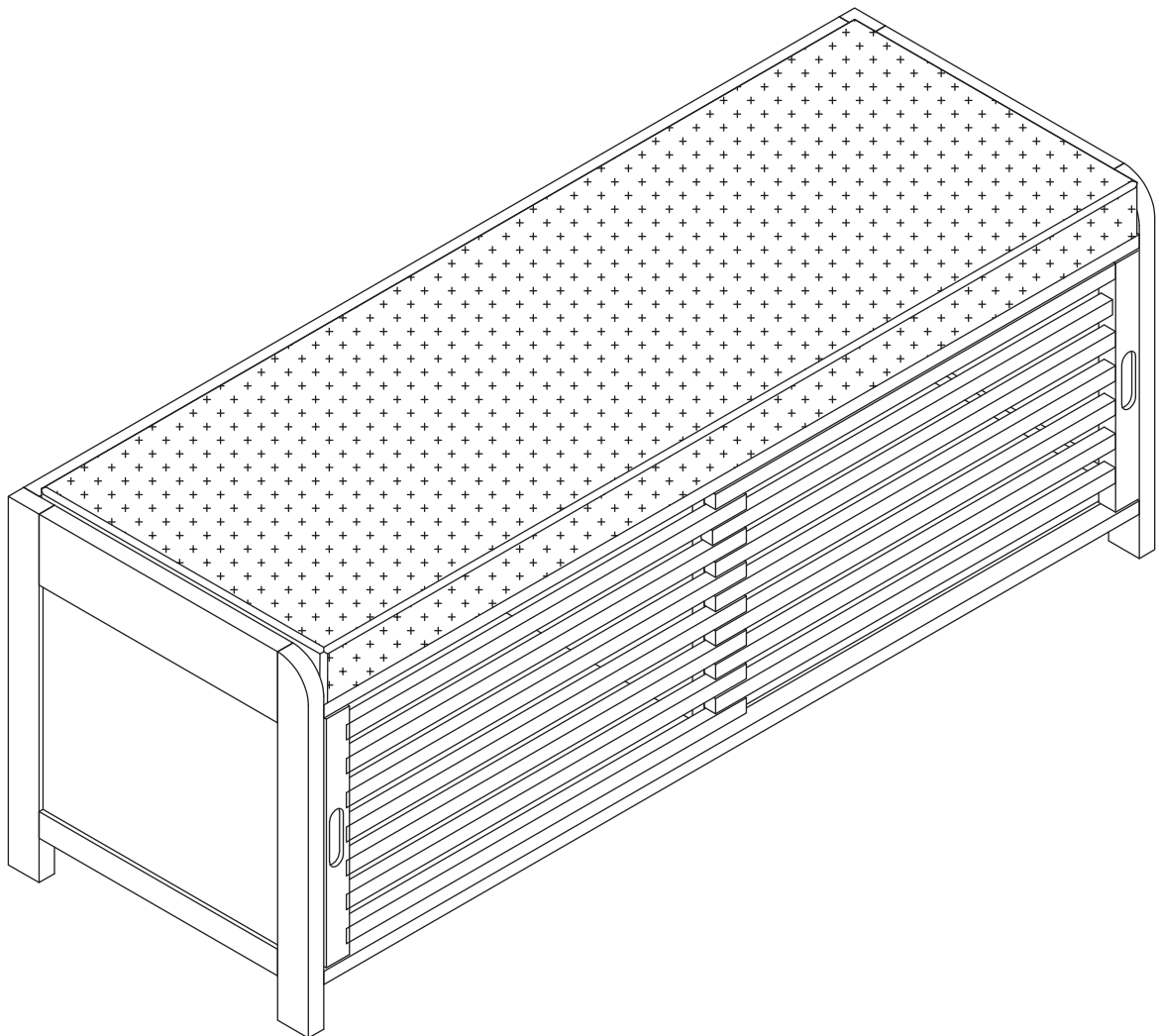

ASSEMBLY INSTRUCTION

Please read these instructions fully before starting assembly:

1. Place all wooden parts on a clean and smooth surface such as a rug or carpet to avoid scratching the parts.
2. Kindly follow the assembly instructions step by step.
3. Do not tighten all screws and bolts until the table is fully assembled.
4. Unscrew the protective plastique supports from the metal insert of the table legs before assembly.
5. Parts of the assembly will be easier with 2 people.

Care and maintenance:

Only clean using a damp cloth and mild detergent, do not use bleach or abrasive cleaners.

ASSEMBLY INSTRUCTION

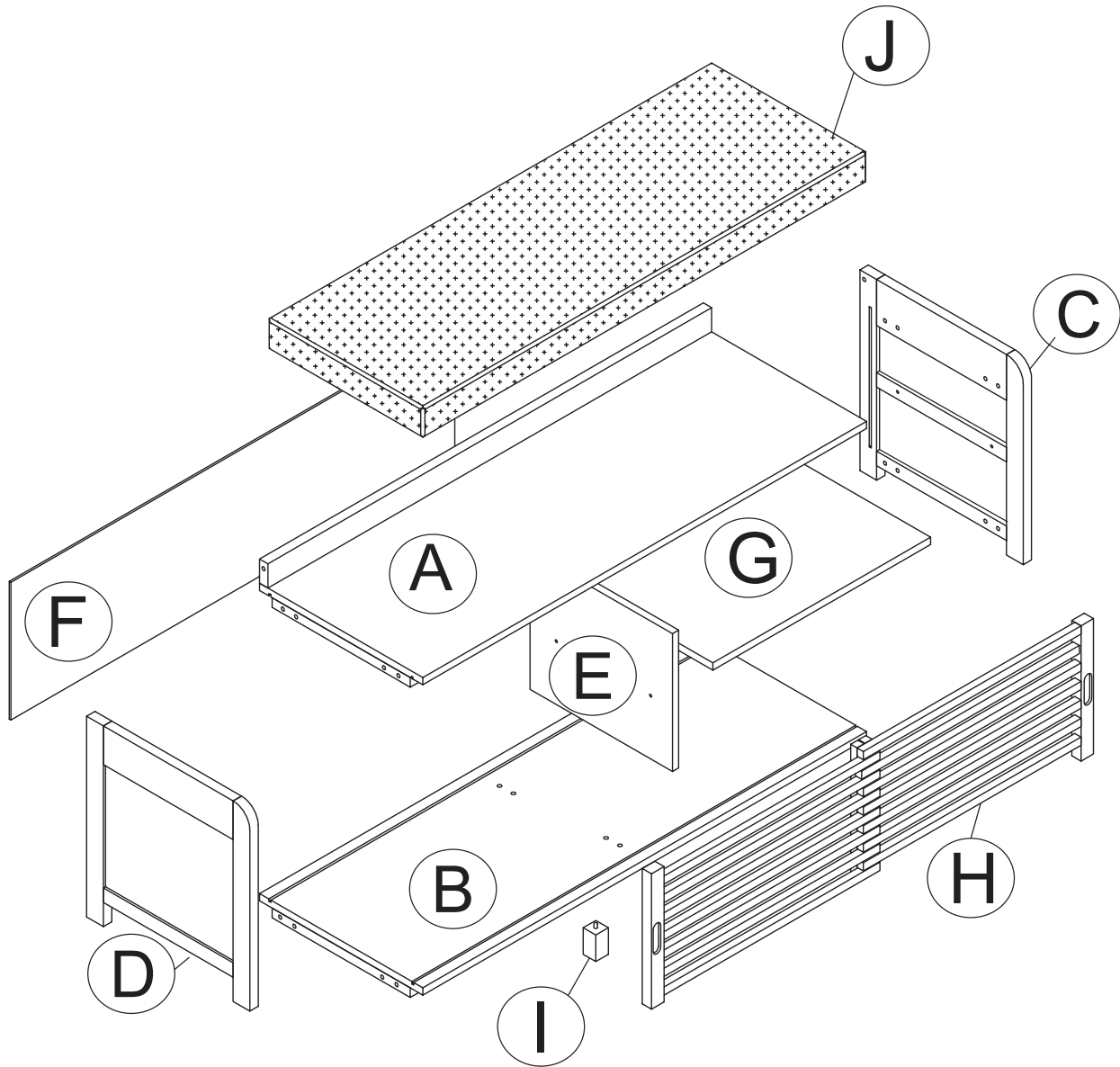

ASSEMBLY INSTRUCTION

Part List

A

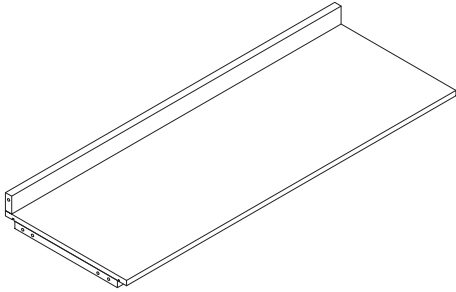

TOP (1 pc)

B

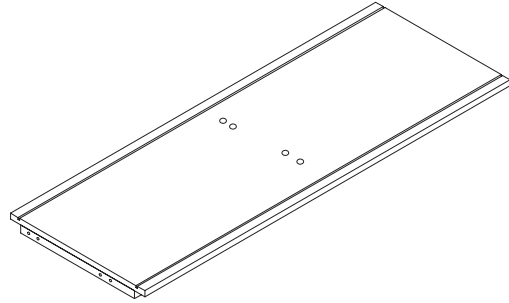

BOTTOM (1 pc)

C

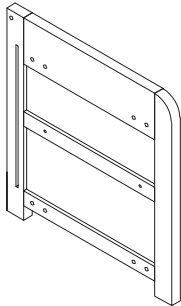

RIGHT SIDE PANEL (1 pc)

D

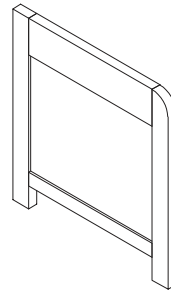

LEFT SIDE PANEL (1 pc)

E

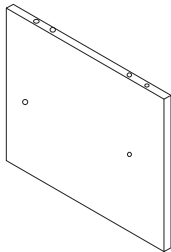

MIDDLE PANEL (1 pc)

F

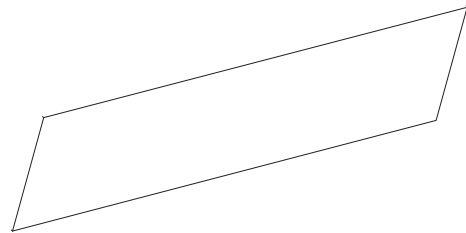

BACK PANEL (1 pc)

G

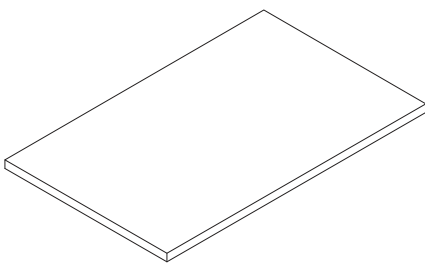

SHELF (1 pc)

H

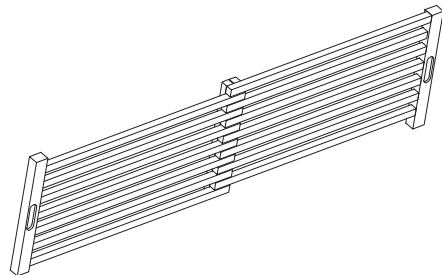

DOOR (1 Set)

I

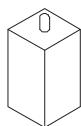

SUPPORT LEG (1 pc)



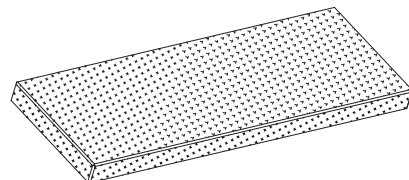





J

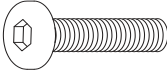
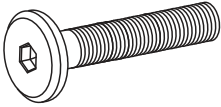

CUSHION (1 pc)

ASSEMBLY INSTRUCTION

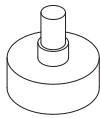

Hardware List

<p>①</p>  <p>Ø 6 x 28 mm</p>	<p>②</p>  <p>Ø 15 x 12 mm</p>
<p>Cam Bolt (2 pcs)</p>	<p>Cam Lock (2 pcs)</p>
<p>③</p>  <p>Ø 8 x 30 mm</p>	<p>④</p>  <p>Ø 6 x 30 mm</p>
<p>Wooden Dowel (14 pcs)</p>	<p>SHORT BOLT (8 pcs)</p>
<p>⑤</p>  <p>Ø6 x 38mm</p>	<p>⑥</p>  <p>Ø6 x 12mm</p>
<p>LONG BOLT (2 pcs)</p>	<p>Flat Washer (10 pcs)</p>
<p>⑦</p>  <p>Ø6 x 12mm</p>	<p>⑧</p>  <p>Ø9 x 12 mm</p>
<p>Lock Washer (10 pcs)</p>	<p>T Nut (2 pcs)</p>
<p>⑨</p>  <p>Allen Key (1 pc)</p>	<p>⑩</p>  <p>Ø6 x 10 mm</p>
<p>⑪</p>  <p>Slide Guide (4 pcs)</p>	<p>⑫</p>  <p>Metal Spindle Lock (4 pcs)</p>

ASSEMBLY INSTRUCTION

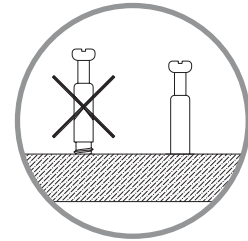
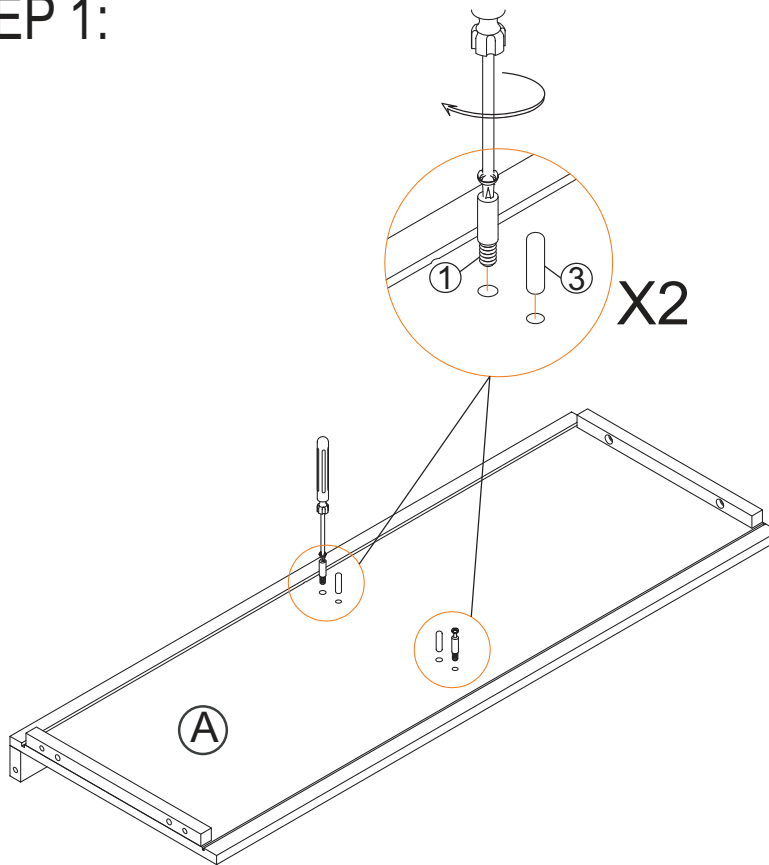

STEP 1:

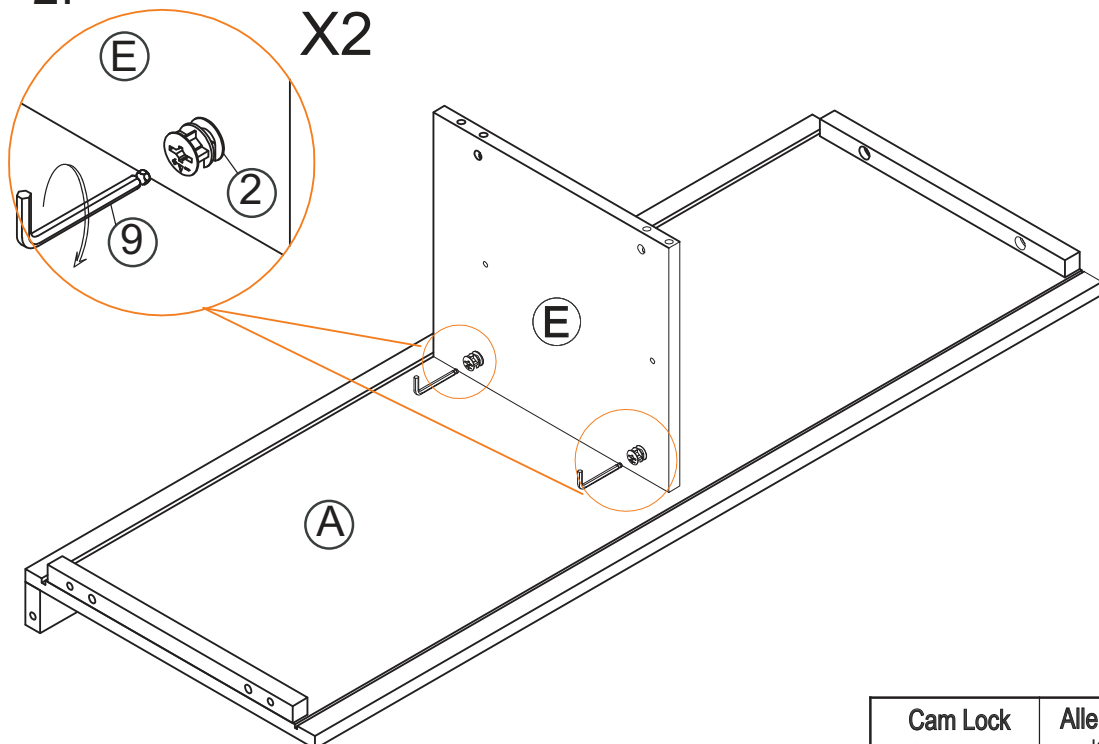

Cam Bolt	Wooden Dowel
Ø 6 x 28 mm	Ø 8 x 30 mm
	
① x 2	③ x 2

STEP 2:





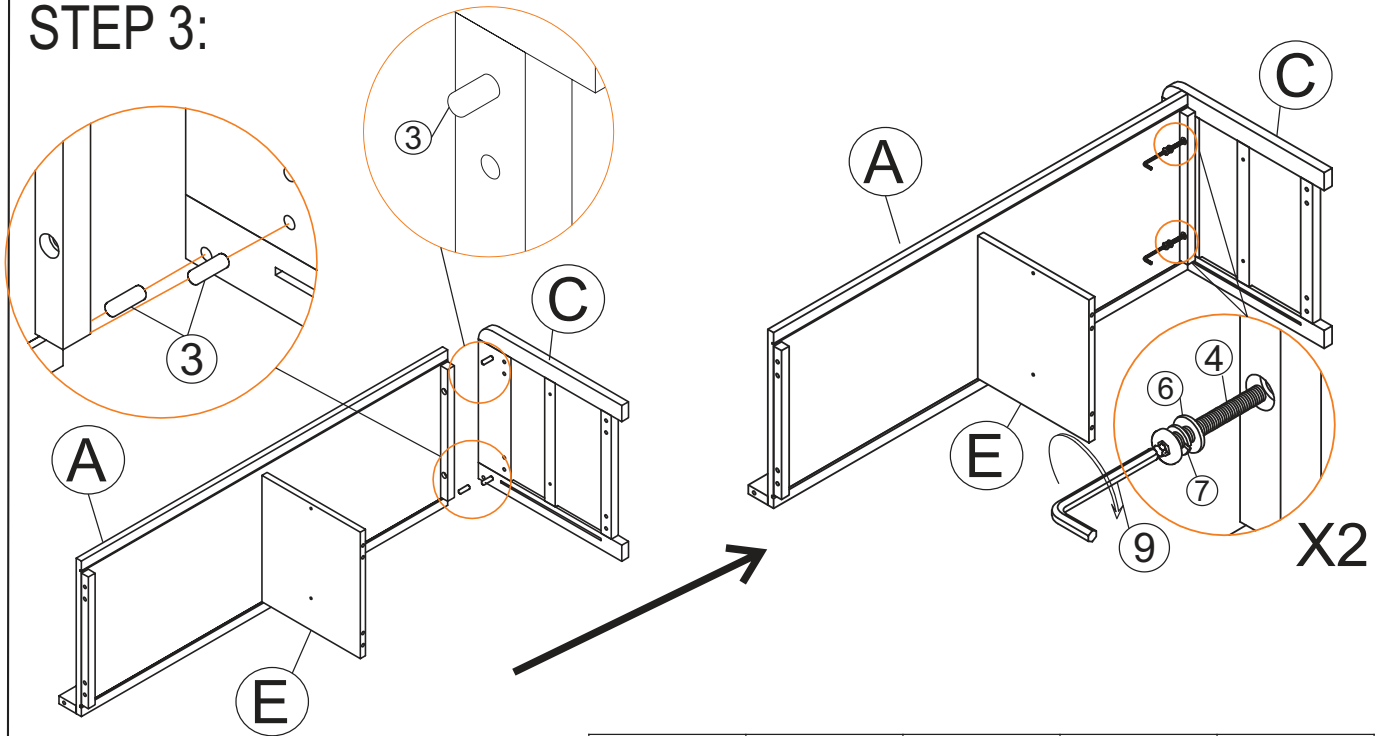

Cam Lock	Allen Key
Ø 15 x 12 mm	K4
	
② x 2	⑨ x 1

ASSEMBLY INSTRUCTION



STEP 3:

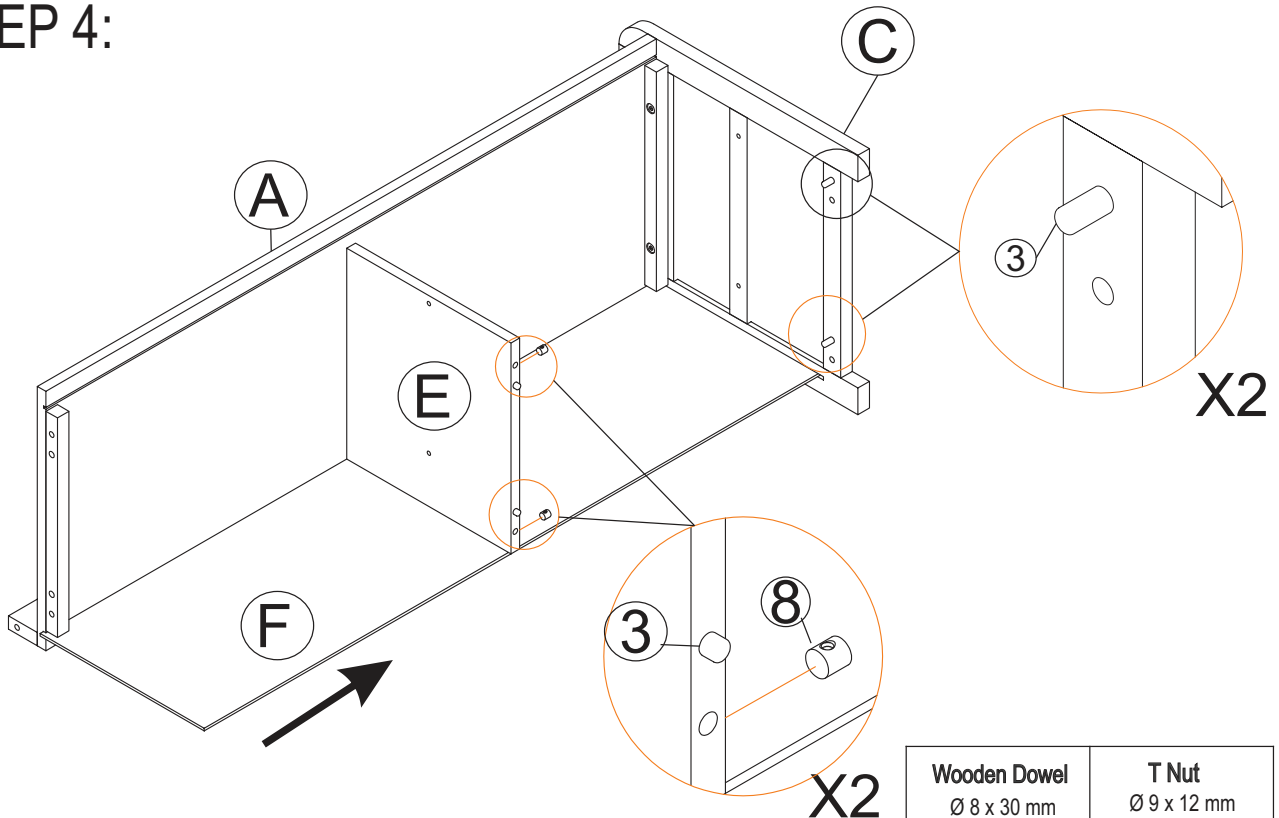

Wooden Dowel	Short Bolt	Flat Washer	Lock Washer	Allen Key
Ø 8 x 30 mm	Ø 6 x 30 mm			K4
				
③ x 3	④ x 2	⑥ x 2	⑦ x 2	⑨ x 1

STEP 4:







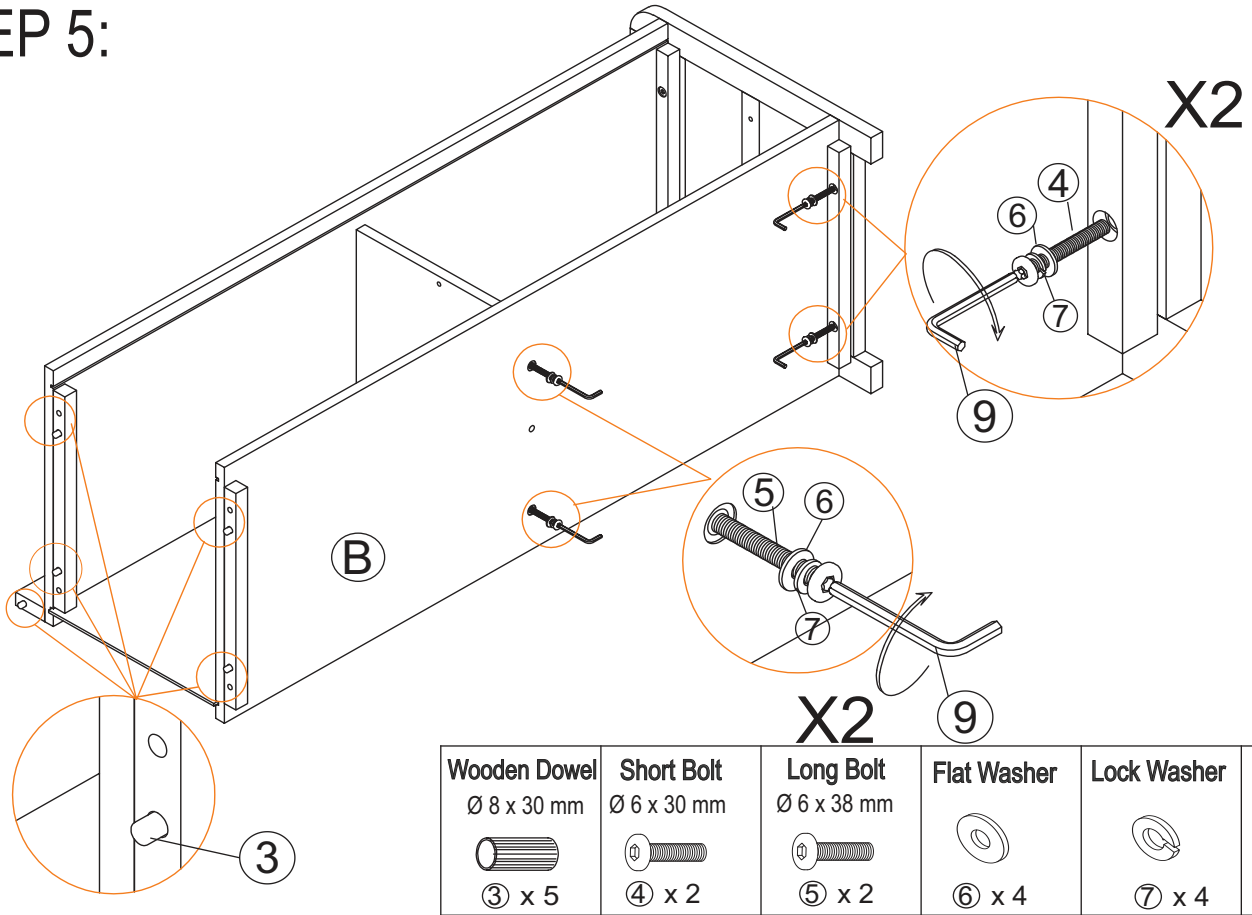

Wooden Dowel	T Nut
Ø 8 x 30 mm	Ø 9 x 12 mm
	
③ x 4	⑧ x 2

ASSEMBLY INSTRUCTION



STEP 5:

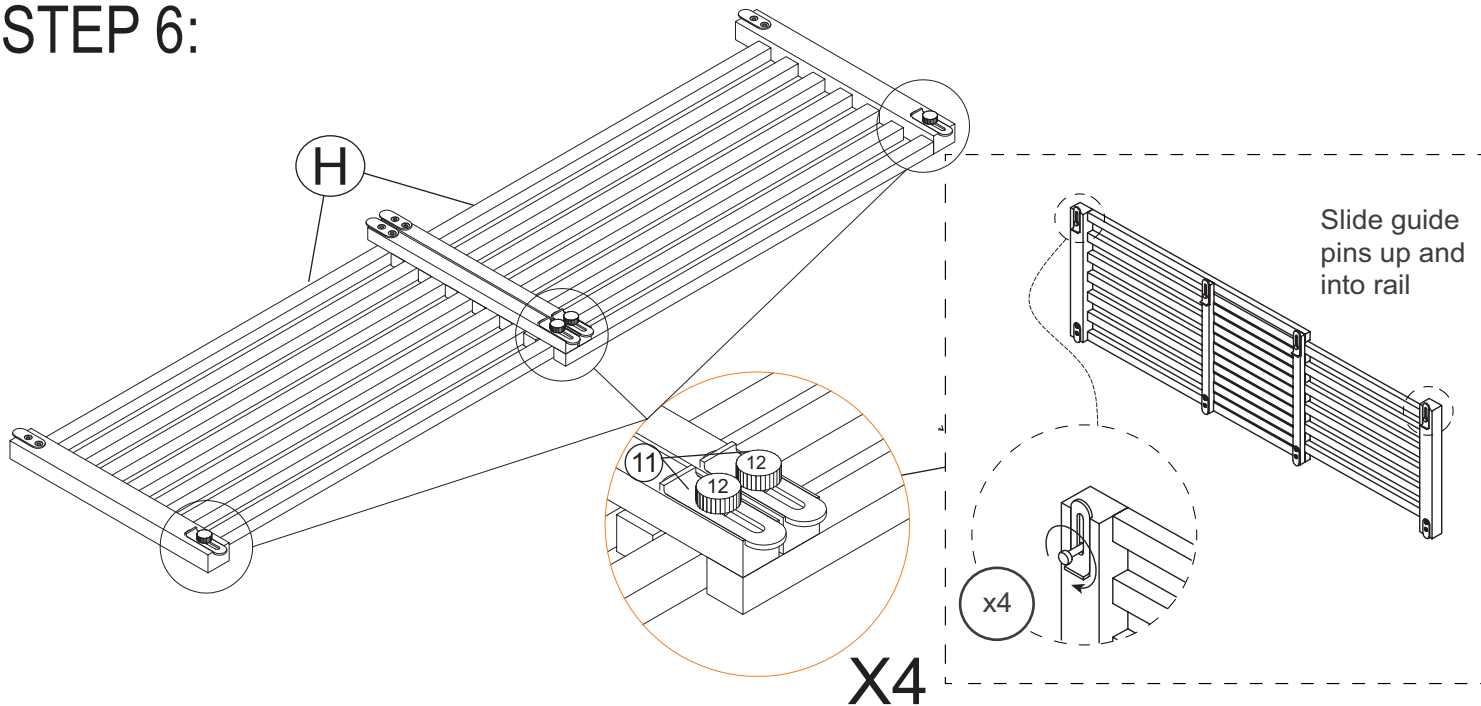

Wooden Dowel Ø 8 x 30 mm	Short Bolt Ø 6 x 30 mm	Long Bolt Ø 6 x 38 mm	Flat Washer	Lock Washer	Allen Key K4
					
③ x 5	④ x 2	⑤ x 2	⑥ x 4	⑦ x 4	⑨ x 1

STEP 6:



Slide Guide 50 x 15 mm	Metal Spindle Lock Ø 4 x 6 mm
	
⑪ x 4	⑫ x 4

ASSEMBLY INSTRUCTION

STEP 7:

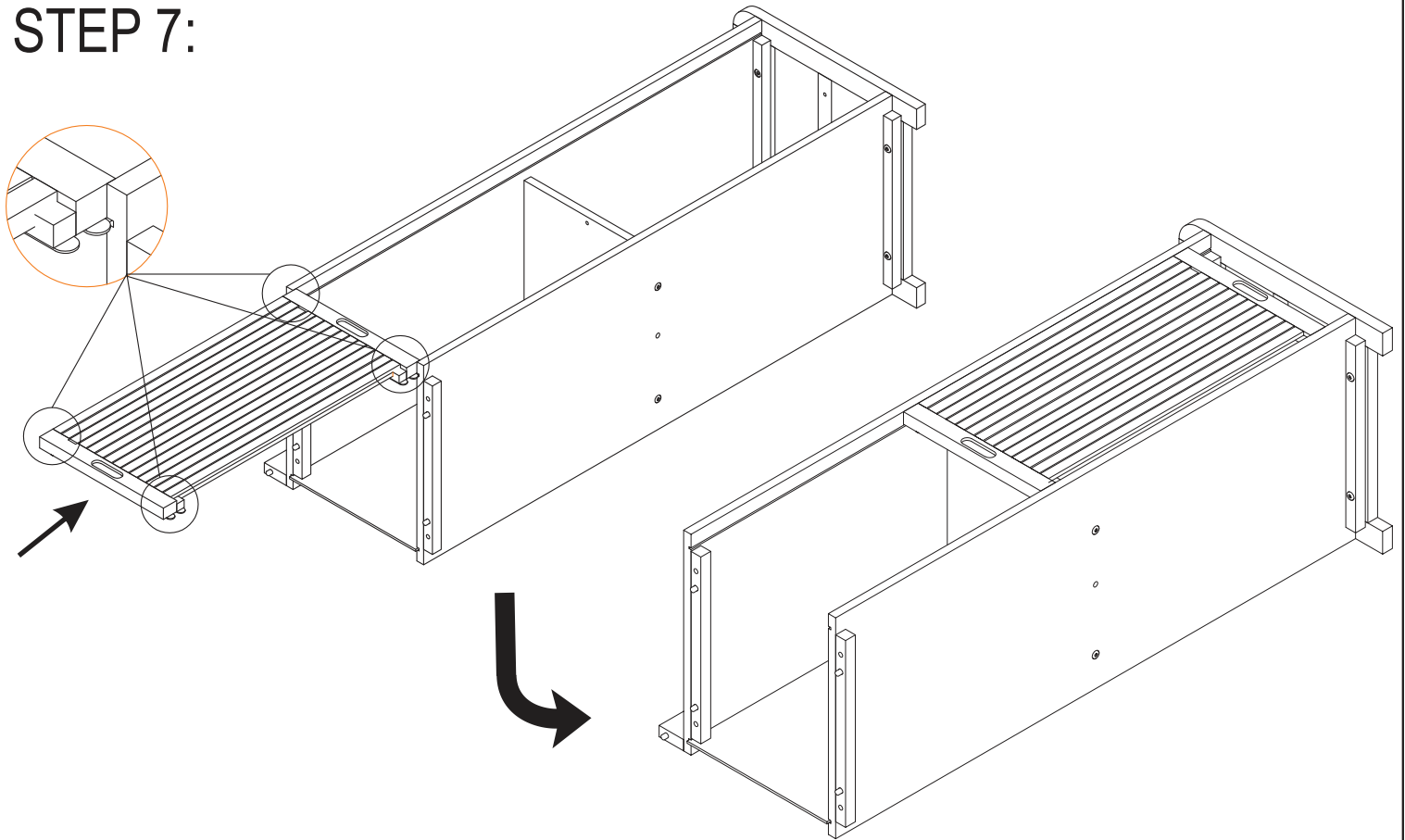

STEP 8:

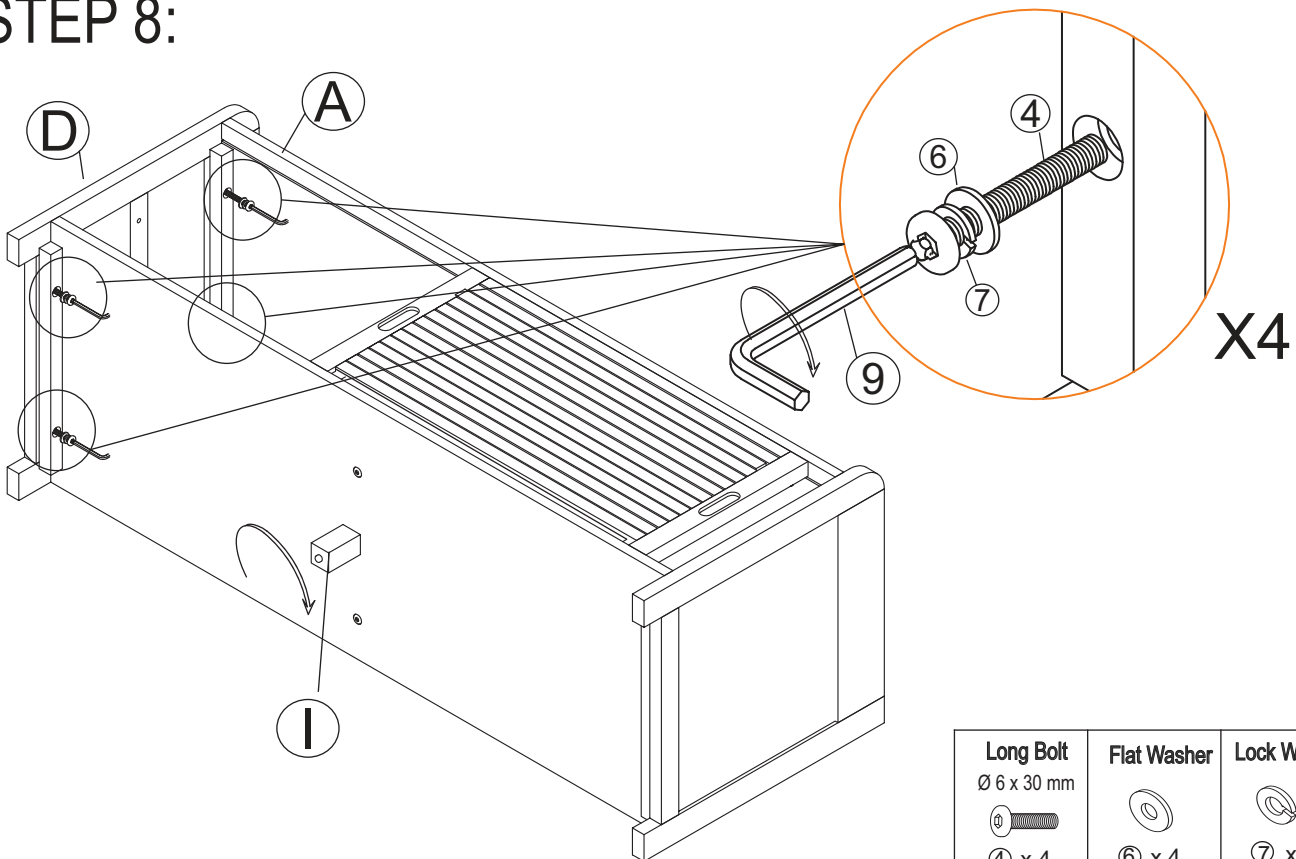

ASSEMBLY INSTRUCTION

STEP 9: The Shelf can be put in the left or right compartment, the process is the same

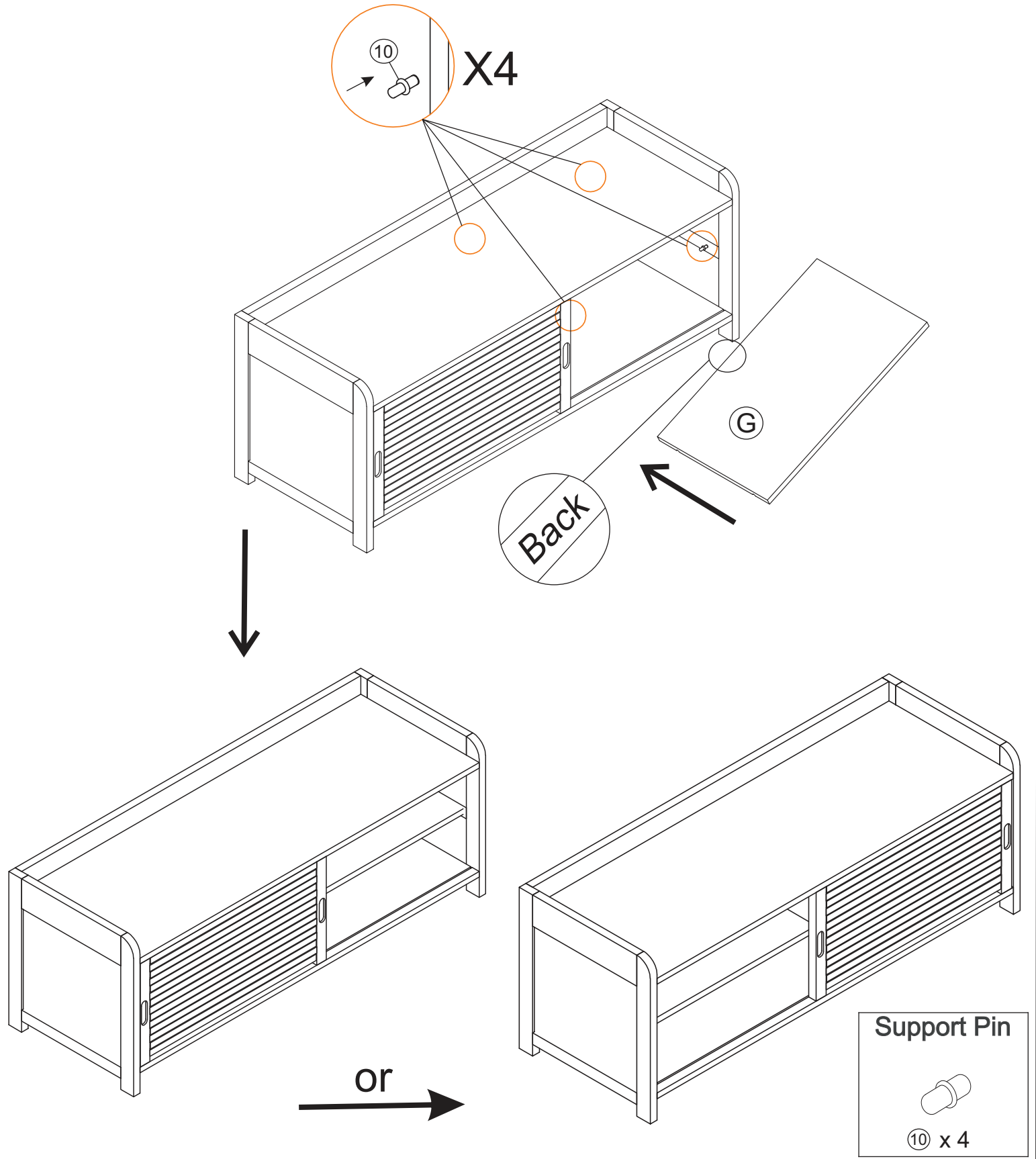

ASSEMBLY INSTRUCTION

STEP 10 :

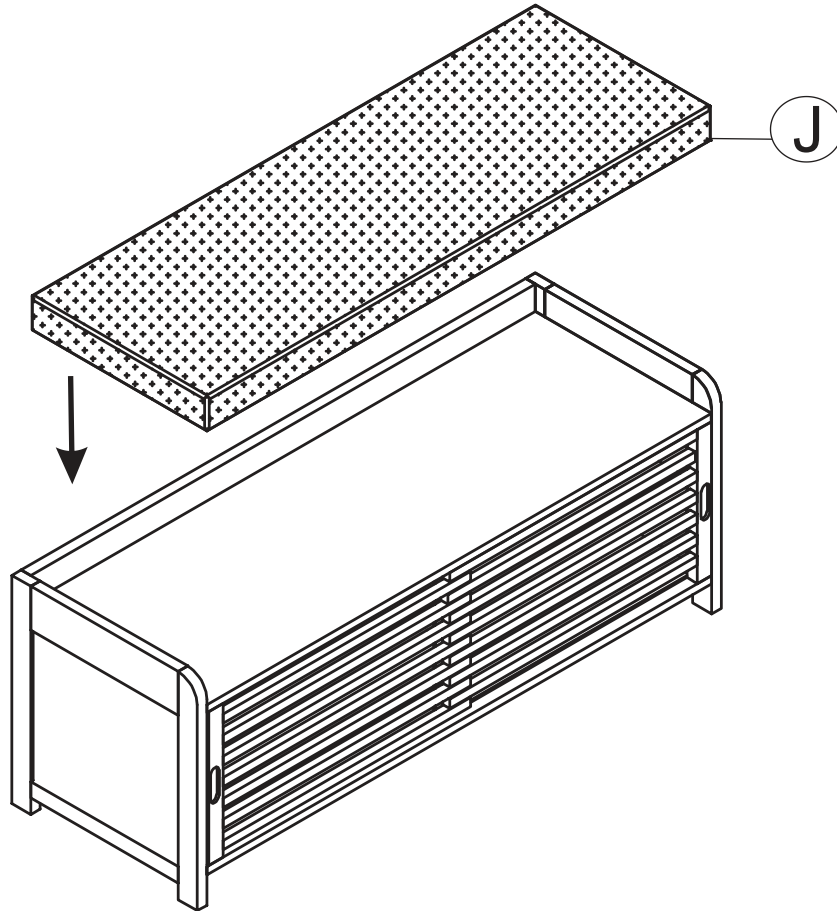

Finished :

