

ASSEMBLY INSTRUCTIONS

TEAKWOOD ROYAL BENCH 5' (ATF02, ATF63)

PARTS.

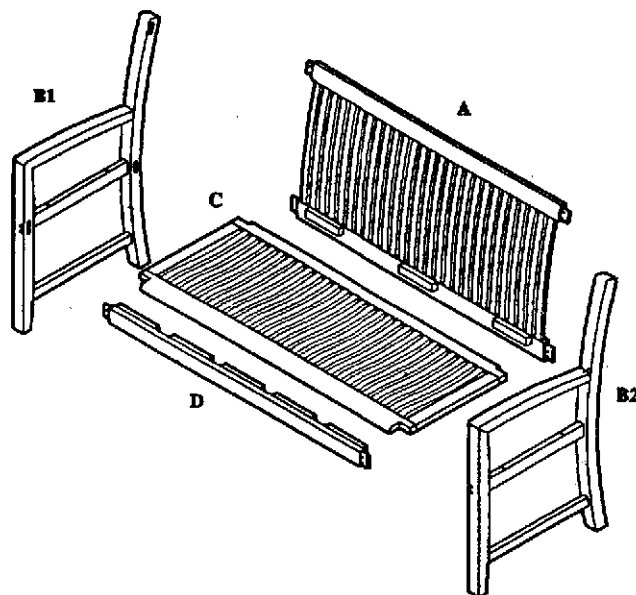

STEP 1.

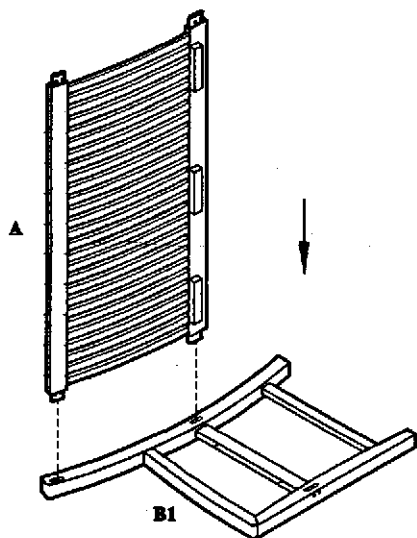

STEP 2.

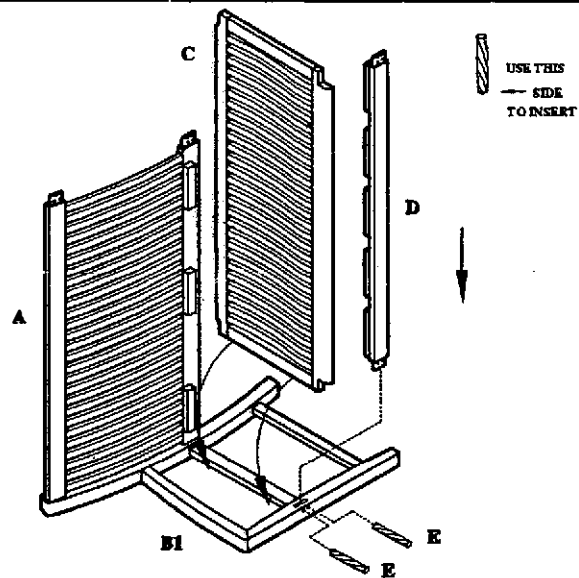



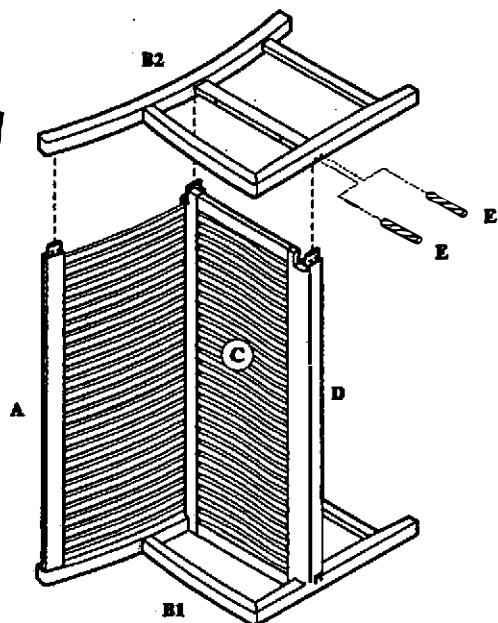

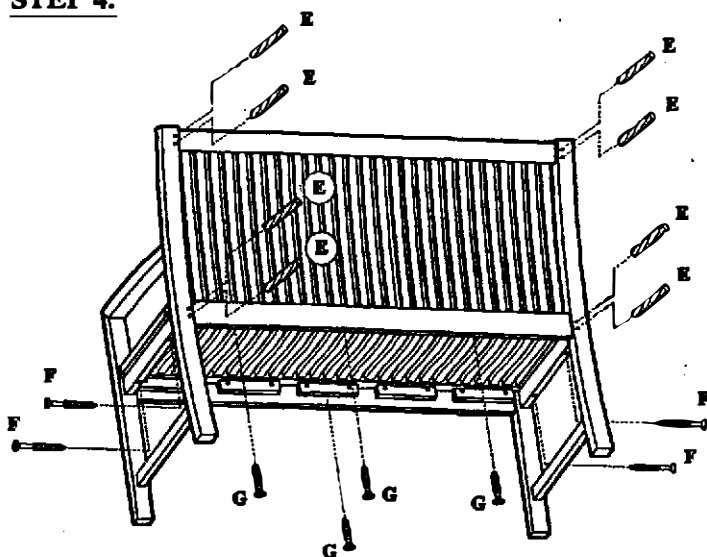

STEP 3.

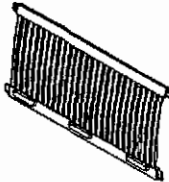
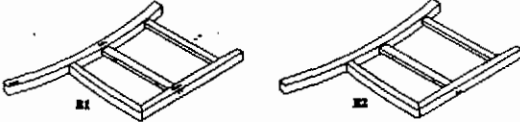
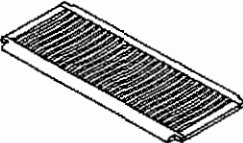
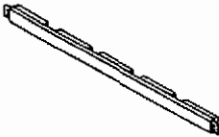

STEP 4.



ASSEMBLY INSTRUCTIONS
TEAKWOOD ROYAL BENCH 5' (ATF02, ATF63)

NO.	PARTS.	QTY.
A	BACKREST 	1
B1,B2	ARM-LEGS 	2
C	SEAT SLATS 	1
D	FRONT STRETCHER 	1
E	LONG DOWEL 	12 (2 EXTRAS)
F	LONG SCREW 	4
G	SHORT SCREW 	4
H	SANDPAPER 	1
I	GLUE 	1

ASSEMBLY INSTRUCTIONS

TEAKWOOD ROYAL BENCH 5' (ATF02, ATF63)

STEP 5-7.

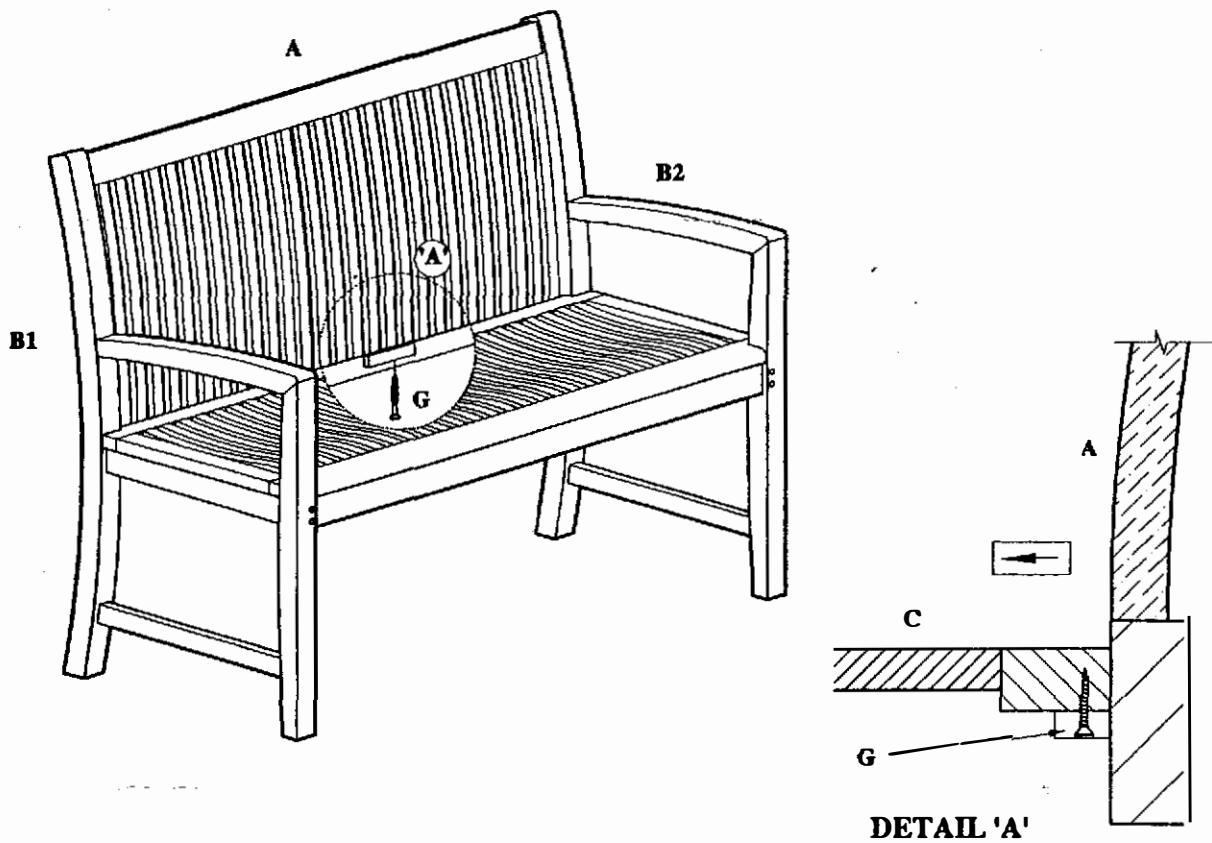

DETAIL 'A'
PRESS BACKREST FIRMLY TO THE BACKSEAT
WHILE TIGHTENING THE SCREW (G)

ASSEMBLY INSTRUCTIONS

Unpack and lay parts on clean flat soft surface to avoid marring wood.

Step 1 Lay the arm-leg (B1) on the floor. Insert the backrest (A) carefully into the side frame.

Step 2 Insert seat slats (C) and front stretcher (D) carefully into the arm-leg as drawing of step 2.

Step 3 With arm-leg (B1), backrest (A) seat slats (C) and front stretcher (D) now firmly in place on one side, put the other arm-leg (B2) onto the other side of (A), (C) and (D)

Step 4 Dip the wooden dowels (E) into glue and insert them into the 12 holes at the front legs and back legs as in drawing of step 4

Step 5 Press both arm-legs (B1) & (B2) tightly to the seat and tighten the long screws (F) from underneath at the specific holes.

Step 6 Press the front stretcher up against the front seat and tighten up the short screws (G) from underneath.

Step 7 Press the back of the backrest to the back seat (C) and tighten up the short screws (G) from underneath.

BE CAREFUL !!! Keep pressing the back of backrest close to the back seat while tightening up the screws.