







# ASSEMBLY INSTRUCTIONS

Thank you for purchasing this quality product . Be sure to check all packaging material carefully for small parts that may have come loose inside the carton during shipment .

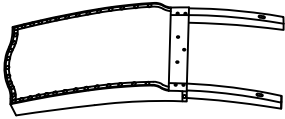
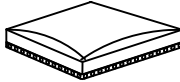

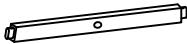



"Hardware is attached underneath the seat bottom"

This product will take 15-20 minutes to assemble

## Components List :

NO	DESCRIPTION	SKETCH	QTY
A	Back Rest		1pc
B	Cushion Seat		1pc
C	Front Leg (Left)		1pc
D	Front Leg (Right)		1pc
E	Side Stretcher (Left)		1pc
F	Side Stretcher (Right)		1pc
G	Center Stretcher		1pc
H	Velcro		1pc

## Hardware List :

NO	DESCRIPTION	SIZE	SKETCH	QTY
1	Allen Key	58x23x4 mm		1pc
2	Short Bolt	1/4" x45 mm		7pcs
3	Long Bolt	1/4" x85 mm		4pcs
4	Spring Washer	5/16" x Ø12		11pcs
5	Flat Washer	5/16" x Ø19		11pcs
6	Wood Screw	Ø8 x 50 mm		6pcs

Screw driver is require for assembly (not included)

### Reminders

1. Use only the hardware supplied.
2. Once the chair is finished, level and tighten all the bolts.
3. Do not over-tighten bolts.
4. This item may require periodic tightening.

### NOTE :

1. Hardware pack is located underneath the Seat Frame with Cushion(B).
2. Two or more people are needed for assembly. Please keep all hardware parts out of the reach of children.

# ASSEMBLY INSTRUCTIONS

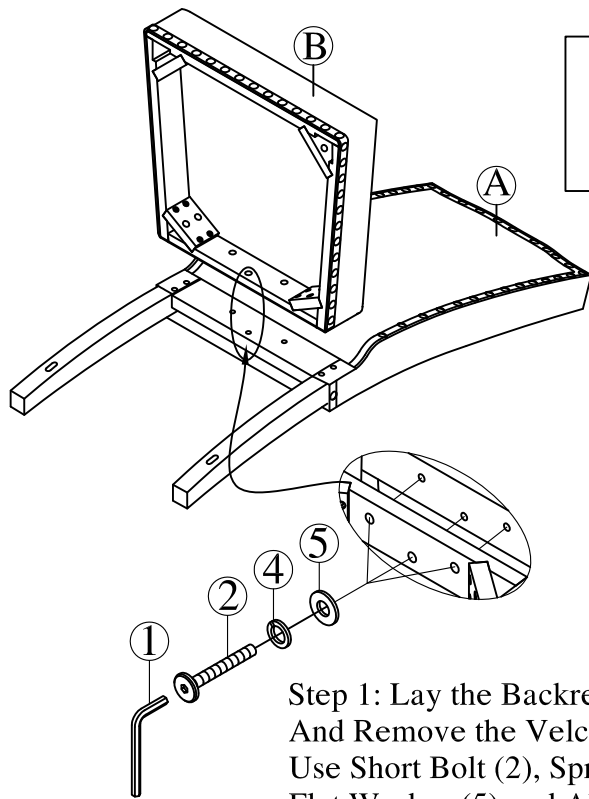

Grab hardware bag from underneath the cushion seat.  
Do not fully tighten bolts until the Product is level  
and the assembly of the product is completed.

Fig.1

Step 1: Lay the Backrest (A) on a flat soft surface,  
And Remove the Velcro (H) from under the Cushion Seat (B)  
Use Short Bolt (2), Spring Washer (4),  
Flat Washer (5) and Allen Key (1) to attached  
the seat Cushion Seat (B) to Backrest (A)  
as shown in Fig. 1.

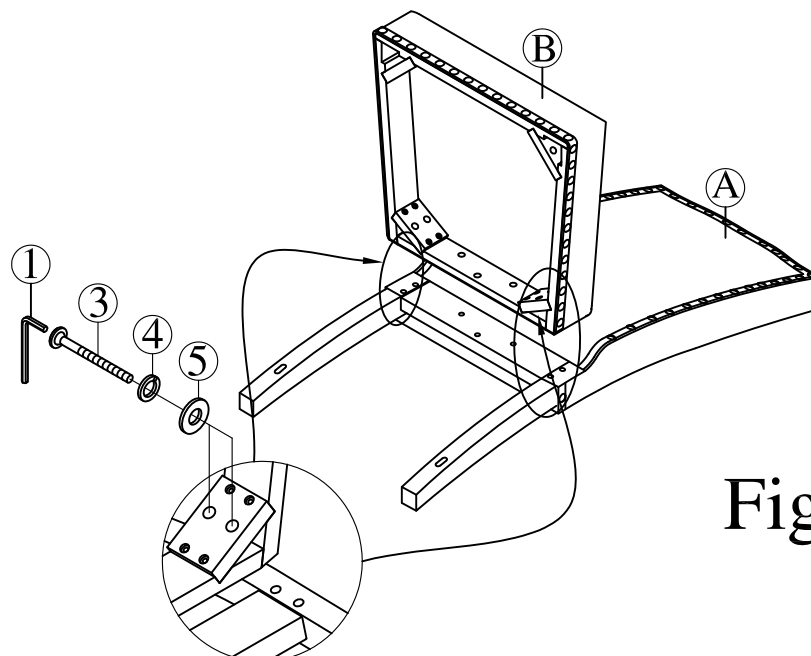

Fig.2

Note: move seat back  
and forward to ease  
the finding of the hole in  
the corner block.

Step 2 : Use Long Bolt (3), Spring Washer (4)  
Flat Washer (5) and Allen Key (1) to attached the Cushion Seat (B) to  
Chair Backrest (A) as shown in Fig. 2 .  
Do not fully tighten bolts yet.

# ASSEMBLY INSTRUCTIONS

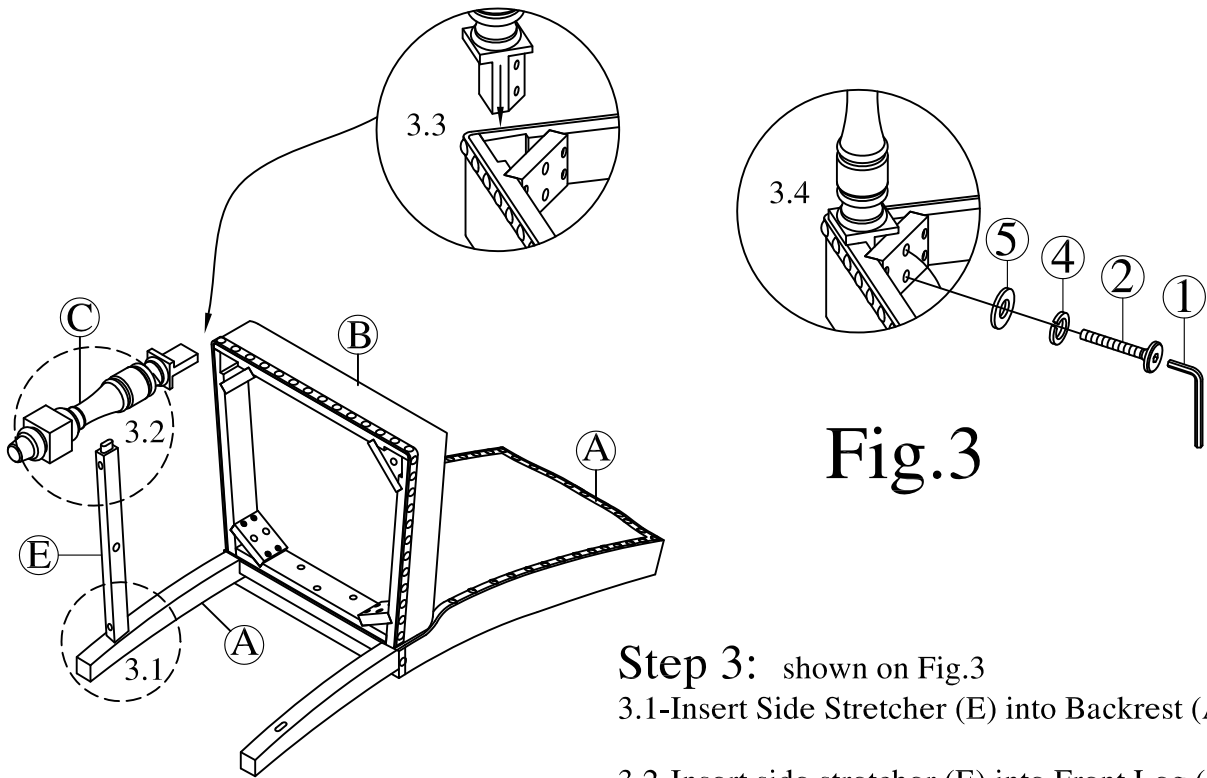

Fig.3

Step 3: shown on Fig.3

3.1-Insert Side Stretcher (E) into Backrest (A).

3.2-Insert side stretcher (E) into Front Leg (C).

3.3- Insert Front leg (C) into Cushion Seat (B).

3.4- Use Short Bolt (2), Spring Washer (4), Flat Washer (5) and tighten with Allen Key (1) to attach Front Leg (C) to Cushion Seat (B).

Do Not Fully Tighten Bolts Yet

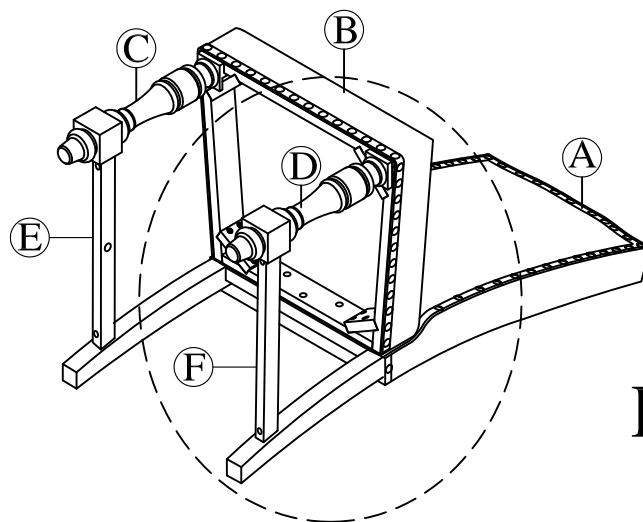

Fig.4

Step 4.

Repeat step 3 to attach the remaining Side Stretcher (F) and Front Leg (D) to Cushion Seat (B) as shown on Fig.4 .

# ASSEMBLY INSTRUCTIONS

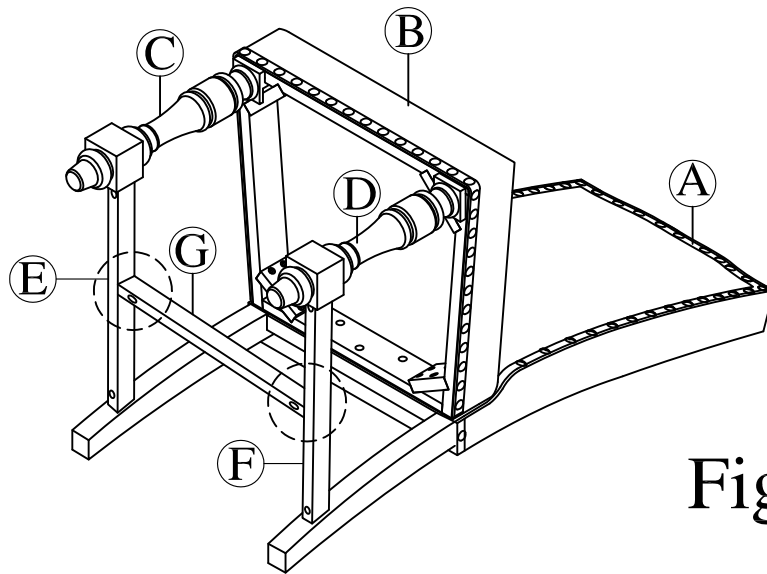

Fig.5

Step 5:  
Insert Center Stretcher (G) Between side stretchers (E & F)  
as shown in Fig 5.

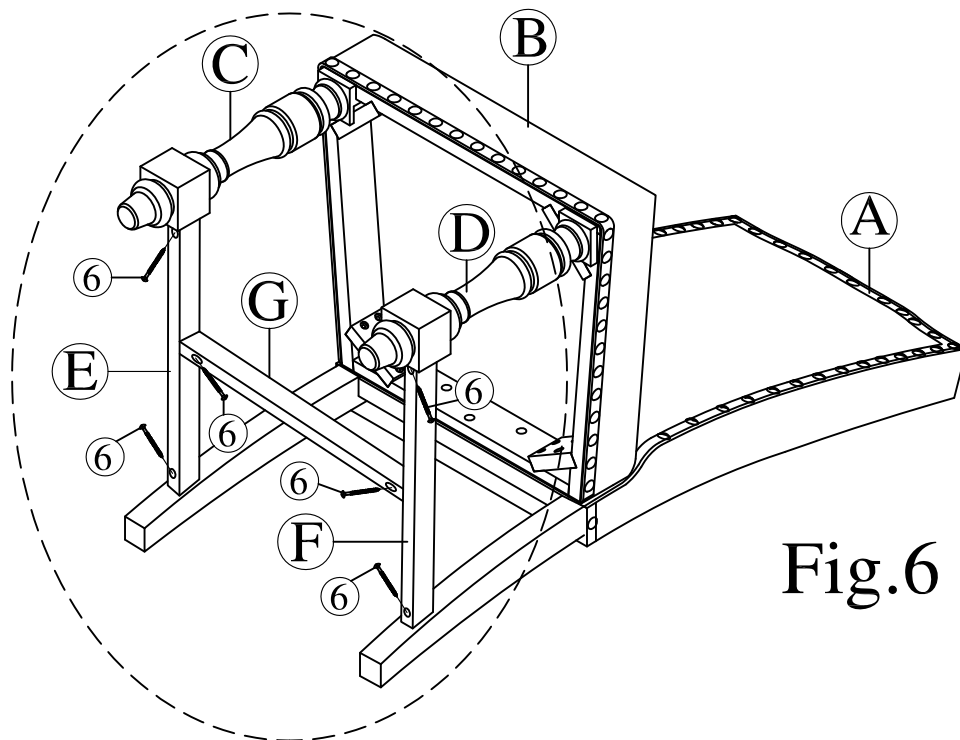

Fig.6

Step 6 : Insert Wood Screw (6) to fasten  
All stretchers (E, F, G) as shown on Fig. 6

# ASSEMBLY INSTRUCTIONS

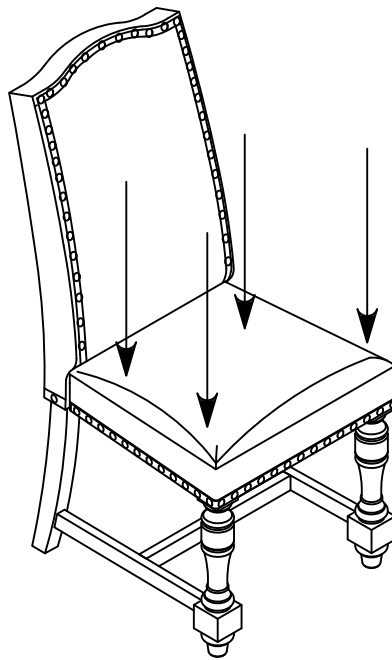

Fig.7

Step 9: Place the loosely assembled chair on a hard flat surface and apply gentle downward pressure on the seat. As shown on Fig.7. Once the chair is balanced and leveled, fully tighten all bolts.

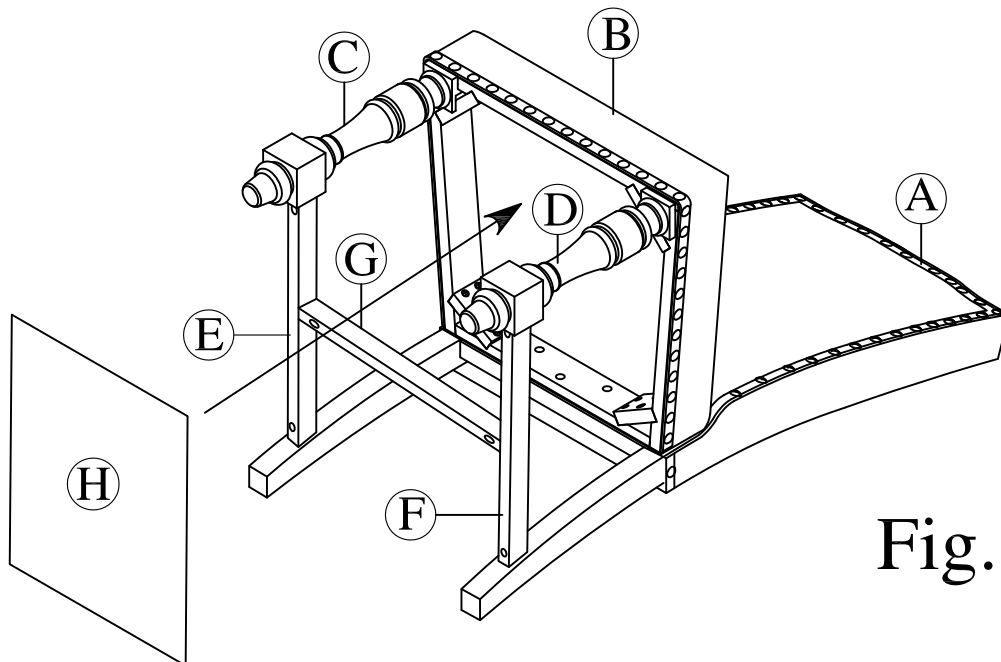

Fig.8

Step 10: Attache Velcro (H) under Cushion Seat (B) as shown in Fig.8

## Assembly is now Complete